

# ANT95-XY Series

**Two Axis, Mechanical Bearing,  
Linear Motor Stage**

**Integrated low-profile XY linear motor stage**

**25 mm x 25 mm or 50 mm x 50 mm travel**

**Nanometer-level performance in a large  
travel format**

**High resolution (1 nm), repeatability  
(75 nm), and accuracy (250 nm) per axis**

**In-position stability of <1 nm**

**Anti-creep crossed-roller bearings**

**High dynamic performance**

nano Motion Technology



## Introduction

Aerotech's ANT series stages are the world's first nanometer-level positioning systems with greater than 25 mm travel. The ANT95-XY crossed-roller-bearing, linear motor, dual-axis stage continues the evolution of the ANT series of stages. The ANT95-XY and ANT95-XY-PLUS are three-piece designs that allow travel in two dimensions (X and Y). The sleek design provides an extremely low profile of only 60 mm. The stage comes with proprietary direct-drive motor technology, noncontact linear encoders, limits, integrated cable management system, and two grades of accuracy.

## Stage Design

The ANT95-XY design allows critical elements such as orthogonality, straightness, and flatness to be optimized, resulting in a stage with exceptional geometrical tolerances. Aerotech's direct-drive technology has no hysteresis or backlash, enabling accurate and repeatable nanometer-scale motion in both the X and Y dimensions. Both travel options (25 mm x 25 mm or 50 mm x 50 mm) come with the 60 mm profile height. You can expect outstanding accuracy, position repeatability, and in-position stability with the ANT95-XY stage.

## Noncontact Direct-Drive

Only noncontact direct-drive technology offers the robust, accurate, and high-speed positioning necessary for mass production of precision devices. ANT95-XY stages utilize advanced direct-drive technology pioneered by Aerotech to achieve the highest level of positioning performance. This direct-drive technology is high-performance, non-cogging, noncontact, high-speed, high-resolution, and high-accuracy.

This unique drive and bearing combination, packaged in an extremely small-profile and footprint, offers tangible advantages in many applications such as high-precision positioning, disk-drive fabrication, fiber alignment, optical delay element actuation, sensor testing, and scanning processes that demand smooth and precise motion. The integrated cable management system is designed for long life and to minimize drag forces.

## Multi-Axis Configurations

The ANT95-XY can be combined with other Aerotech ANT series products (vertical lift stages, direct-drive rotaries, and goniometers) to create unique, high performance, multi-axis systems.

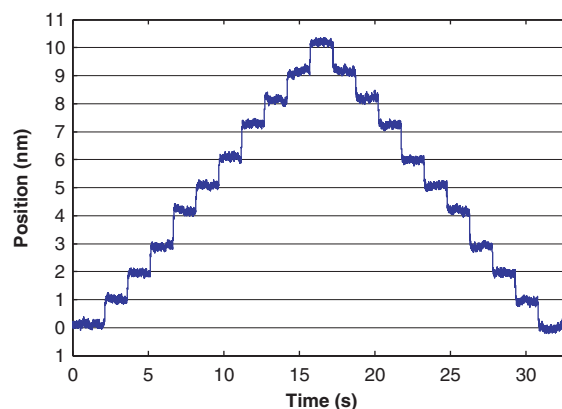

*ANT95-25-XY-PLUS lower axis 1 nm step plot. Best-in-class resolution and exceptional in-position stability for large travel stages.*

## ANT95-XY Series SPECIFICATIONS

Mechanical Specifications	ANT95-25-XY	ANT95-25-XY-PLUS	ANT95-50-XY	ANT95-50-XY-PLUS
Travel	25 mm	25 mm	50 mm	50 mm
Accuracy <sup>(1)</sup>	±2.5 µm (±100 µin)	±250 nm (±10 µin)	±2.5 µm (±100 µin)	±250 nm (±10 µin)
Resolution	1 nm (0.04 µin)	1 nm (0.04 µin)	1 nm (0.04 µin)	1 nm (0.04 µin)
Repeatability (Bi-Directional) <sup>(1)</sup>	±100 nm (±4 µin)	±75 nm (±3 µin)	±100 nm (±4 µin)	±75 nm (±3 µin)
Repeatability (Uni-Directional)	±25 nm (±1 µin)	±25 nm (±1 µin)	±25 nm (±1 µin)	±25 nm (±1 µin)
Straightness <sup>(1)</sup>	±1.0 µm (±40 µin)	±1.0 µm (±40 µin)	±1.0 µm (±40 µin)	±1.0 µm (±40 µin)
Flatness <sup>(1)</sup>	±1.0 µm (±40 µin)	±1.0 µm (±40 µin)	±1.0 µm (±40 µin)	±1.0 µm (±40 µin)
Pitch	10 arc sec	10 arc sec	10 arc sec	10 arc sec
Roll	10 arc sec	10 arc sec	10 arc sec	10 arc sec
Yaw	5 arc sec	5 arc sec	5 arc sec	5 arc sec
Orthogonality	10 arc sec	3 arc sec	10 arc sec	3 arc sec
Maximum Speed	500 mm/s (20 in/s) (Upper Axis)	500 mm/s (20 in/s) (Upper Axis)	500 mm/s (20 in/s) (Upper Axis)	500 mm/s (20 in/s) (Upper Axis)
Maximum Acceleration	4.5 g - 45 m/s <sup>2</sup> (No Load) (Upper Axis)	4.5 g - 45 m/s <sup>2</sup> (No Load) (Upper Axis)	2.75 g - 27 m/s <sup>2</sup> (No Load) (Upper Axis)	2.75 g - 27 m/s <sup>2</sup> (No Load) (Upper Axis)
Speed Stability	See graph for typical performance			
Settling Time	See graph for typical performance			
In-Position Stability <sup>(2)</sup>	<1 nm (<0.04 µin)	<1 nm (<0.04 µin)	<1 nm (<0.04 µin)	<1 nm (<0.04 µin)
Maximum Force (Continuous)	7.75 N	7.75 N	9.5 N	9.5 N
Load Capacity <sup>(3)</sup>	Horizontal	4.0 kg (8.8 lb)	4.0 kg (8.8 lb)	6.0 kg (13.2 lb)
	Upper Axis	0.45 kg (1.0 lb)	0.45 kg (1.0 lb)	0.8 kg (1.8 lb)
	Lower Axis	1.13 kg (2.5 lb)	1.13 kg (2.5 lb)	2.1 kg (4.6 lb)
Stage Mass	1.8 kg (4 lb)	1.8 kg (4 lb)	3.2 kg (7 lb)	3.2 kg (7 lb)
Material	Aluminum Body/Black Hardcoat Finish			
MTBF (Mean Time Between Failure)	20,000 Hours			

Notes:

1. Certified with each stage.

2. In-Position Jitter listing is 3 sigma value.

3. Axis orientation for on-axis loading is listed.

• Specifications are per axis, measured 25 mm above the tabletop. Consult factory for multi-axis or non-standard applications.

• -PLUS requires the use of an Aerotech controller.

Electrical Specifications	ANT95-25-XY	ANT95-25-XY-PLUS	ANT95-50-XY	ANT95-50-XY-PLUS
Drive System	Brushless Linear Servomotor			
Feedback	Noncontact Linear Encoder			
Maximum Bus Voltage	±40 VDC			
Limit Switches	5 V, Normally Closed			
Home Switch	Near Center			

Recommended Controller	ANT95-25-XY	ANT95-25-XY-PLUS	ANT95-50-XY	ANT95-50-XY-PLUS
Multi-Axis	A3200	Npaq-MXR Npaq MR-MXH Ndrive ML-MXH		
	Ensemble	Epaq-MXH Epaq MR-MXH Ensemble ML-MXH		
Single Axis	Soloist	Soloist ML-MXH		

Notes:

1. Linear amplifiers are required to achieve the listed specifications. Other options are available.

Note: To ensure the achievement and repeatability of specifications over an extended period of time, environmental temperature must be controlled to within 0.25°C/24 hours. If this is not possible, alternate products are available. Please consult Aerotech Application Engineering for more information.

# ANT95-XY/ANT95-XY-PLUS Series PERFORMANCE

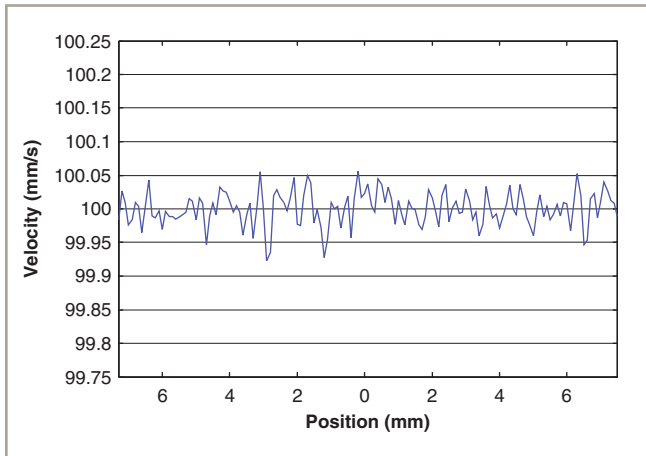

ANT95-25-XY-PLUS velocity performance at 100 mm/s and 1 kg payload for the X (lower) axis. This outstanding speed stability enhances most scanning or laser machining applications.

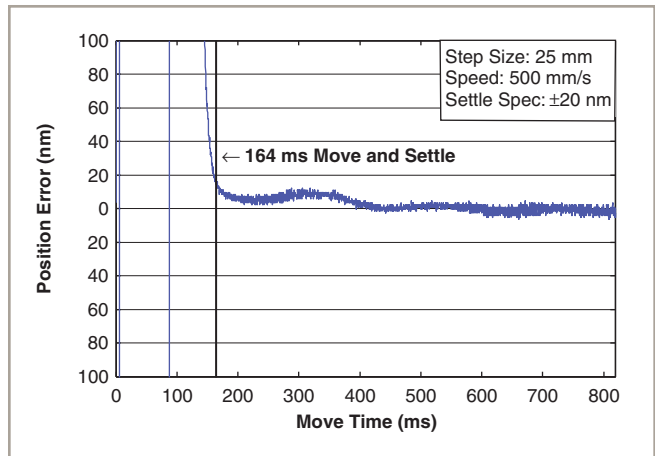

ANT95-25-XY-PLUS step and settle performance at full travel and 1 kg payload for the X (lower) axis. Industry-best settling times significantly improve throughput for most applications.

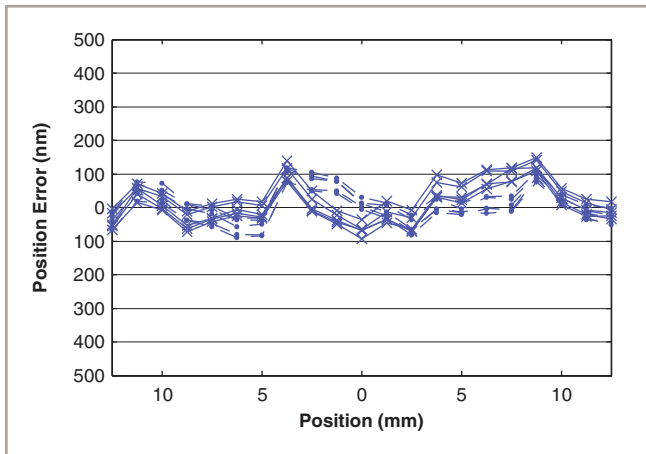

ANT95-25-XY-PLUS accuracy and repeatability, five runs, bi-directional for the X (lower) axis. The total accuracy of 240 nm over 25 mm travel is significantly better than other offerings and half of its stated specification.

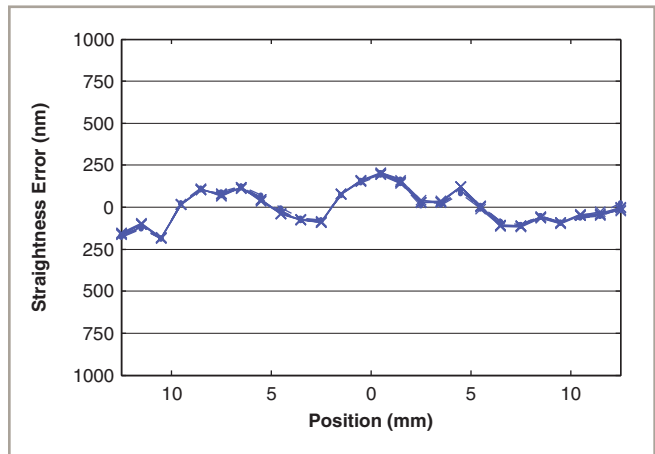

ANT95-25-XY-PLUS bi-directional straightness error for the Y (upper) axis. Significantly (five times) better than stated specification.

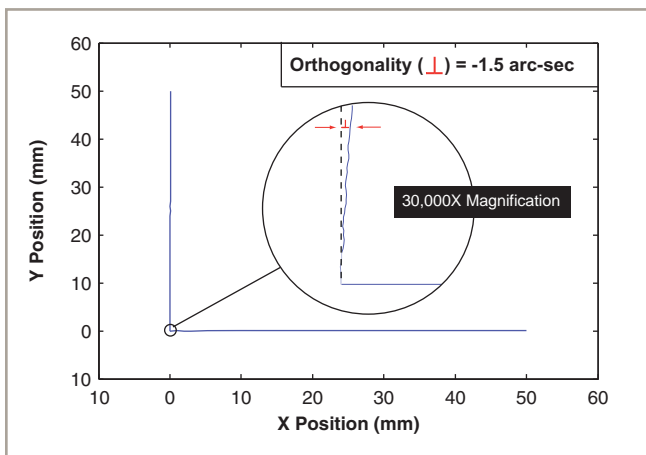

ANT95-50-XY-PLUS orthogonality. The inset is exaggerated 30,000X for clarity. Exceptionally small angular (orthogonality) error significantly enhances system accuracy.

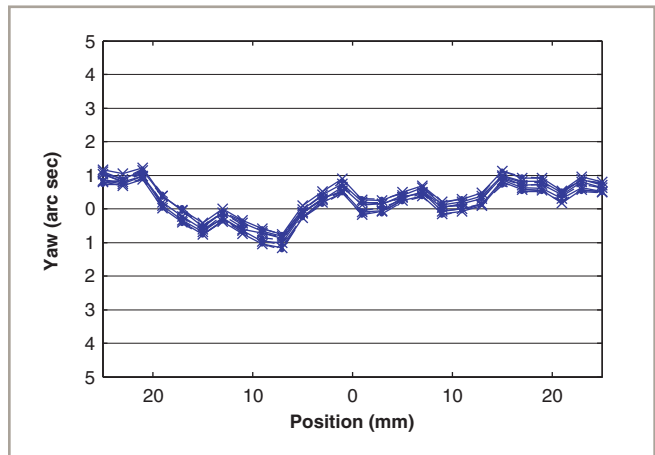

ANT95-50-XY-PLUS Y (upper) axis yaw, five runs, bi-directional. Highly repeatable, lowest angular error over full travel.

ANT95-25-XY/ANT95-25-XY-PLUS DIMENSIONS

ANT95-25-XY/ANT95-25-XY-PLUS

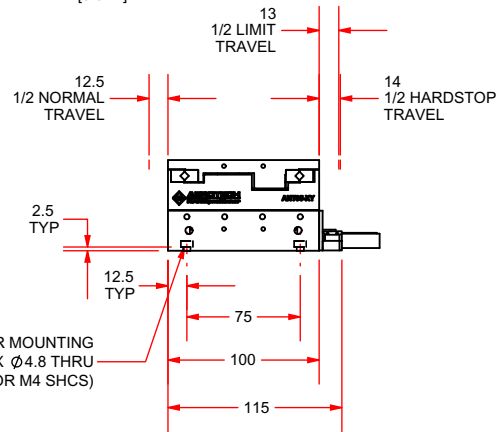
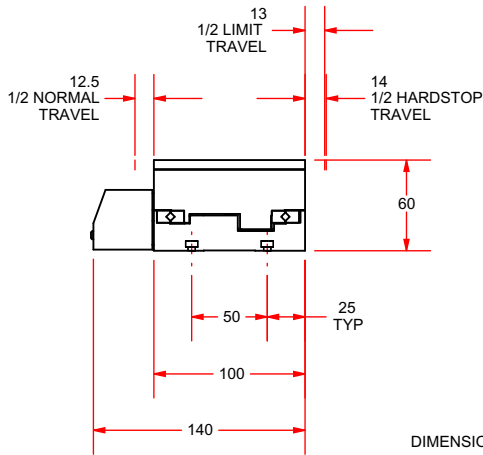
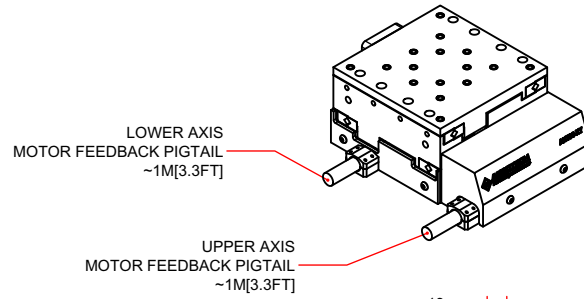
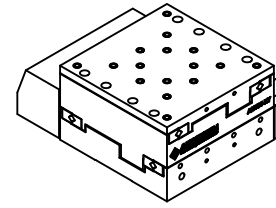
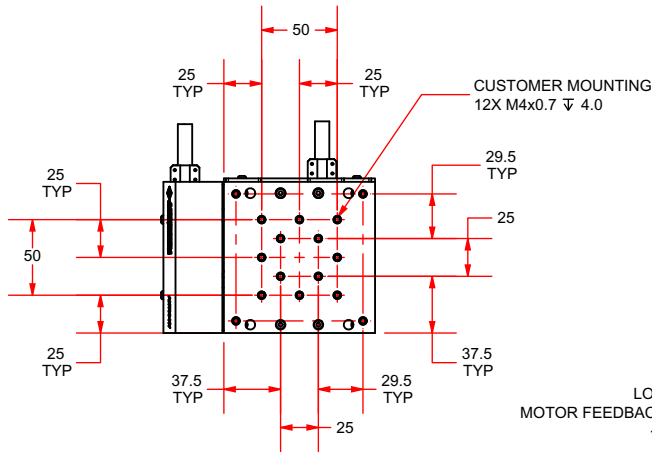

DIMENSIONS: MILLIMETERS

# ANT95-50-XY/ANT95-50-XY-PLUS DIMENSIONS

## ANT95-50-XY/ANT95-50-XY-PLUS

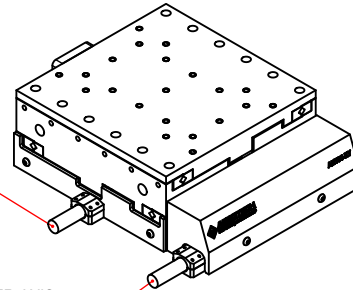
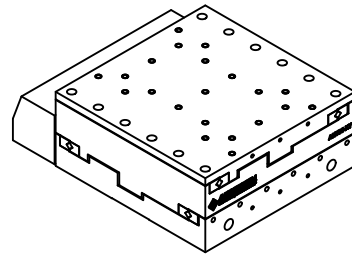
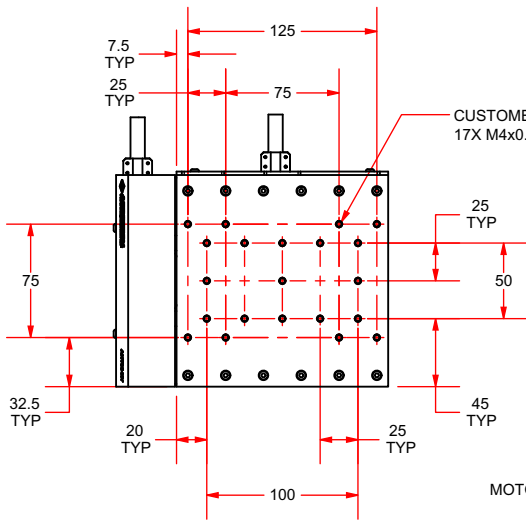

LOWER AXIS  
MOTOR FEEDBACK PIGTAIL  
~1M[3.3FT]

UPPER AXIS  
MOTOR FEEDBACK PIGTAIL  
~1M[3.3FT]

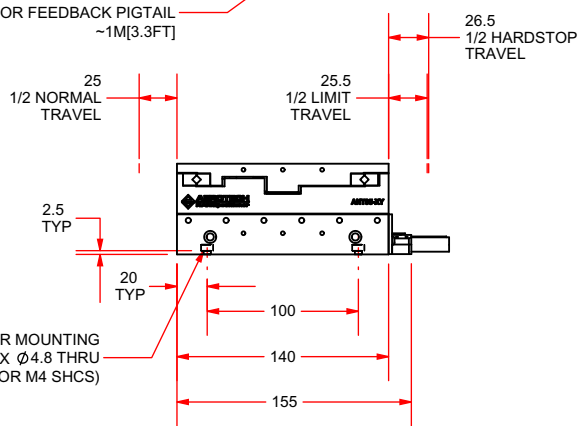
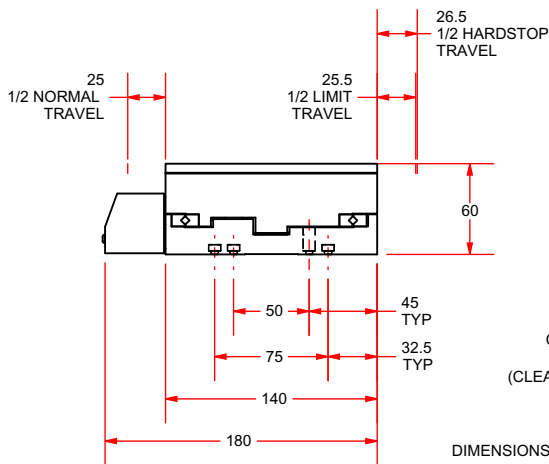

DIMENSIONS: MILLIMETERS

ANT95-25-XY/ANT95-50-XY and ANT95-25-XY-PLUS/ANT95-50-XY-PLUS Mounting Plate DIMENSIONS

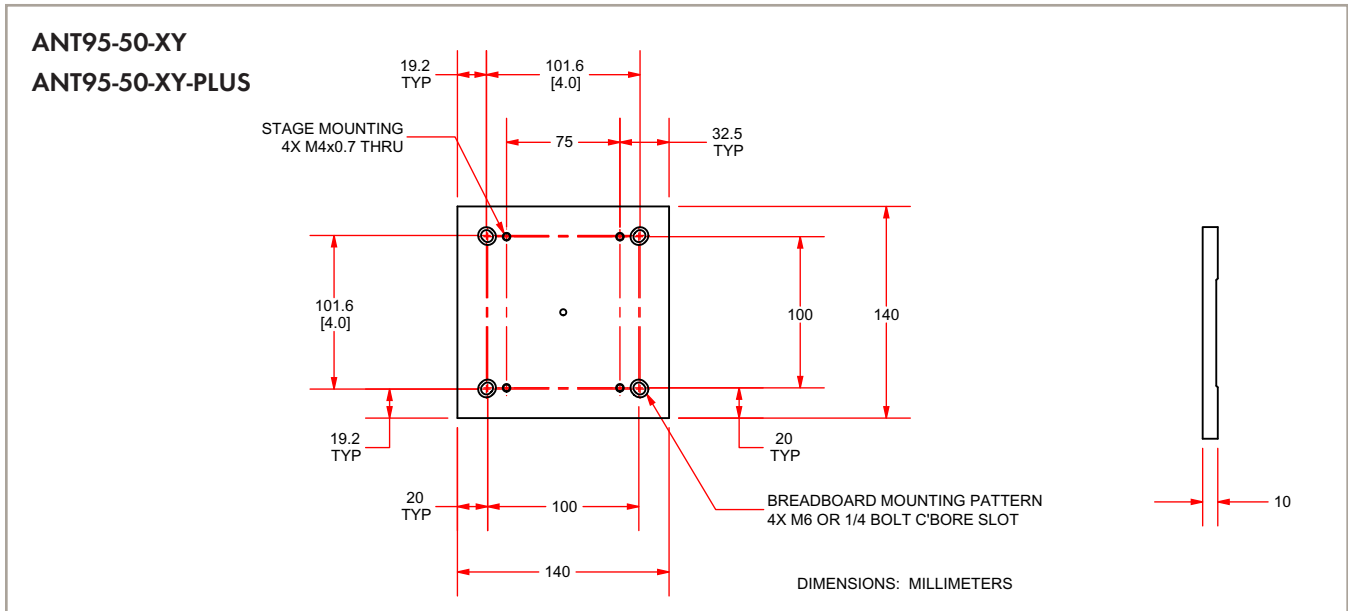
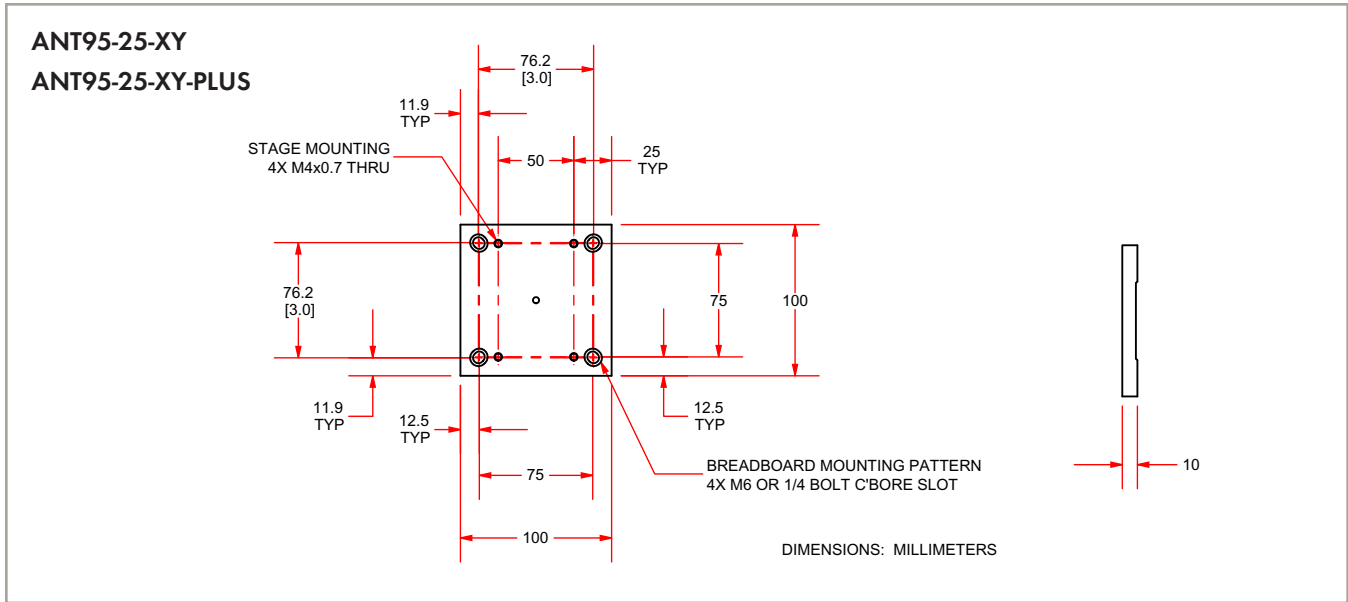

ANT95-XY Series ORDERING INFORMATION

ANT95-XY Series Linear Stage

ANT95-XY/ANT95-XY-PLUS Aerotech nanotranslation crossed-roller linear positioner

Linear Stage Travel

ANT95-25-XY	25 mm (1 in) XY travel stage with proprietary direct-drive motor technology, 1 Vp-p sinusoidal output linear encoder, and limits
ANT95-25-XY-PLUS	25 mm (1 in) XY travel stage with proprietary direct-drive motor technology, 1 Vp-p sinusoidal output linear encoder, and limits (High Accuracy Version)
ANT95-50-XY	50 mm (2 in) XY travel stage with proprietary direct-drive motor technology, 1 Vp-p sinusoidal output linear encoder, and limits
ANT95-50-XY-PLUS	50 mm (2 in) XY travel stage with proprietary direct-drive motor technology, 1 Vp-p sinusoidal output linear encoder, and limits (High Accuracy Version)

Options

-MP Breadboard mounting plate