

ANT95-L-Z Series

Mechanical-Bearing

Linear Motor Vertical Stage

Nanometer performance in a large travel format (25 and 50 mm)

High resolution (2 nm), repeatability (75 nm), and accuracy (300 nm)

In-position stability of <2 nm

Anti-creep crossed-roller bearings

High dynamic performance

nano Motion Technology



Introduction

Aerotech's ANT series stages are the world's first nanometer-level positioning systems with greater than 25 mm travel. The ANT95-L-Z and ANT95-L-Z-PLUS crossed-roller stages are the best-in-class in combining speed, accuracy, resolution, repeatability, reliability, and size, and are offered in two accuracy grades. As an evolution of the ANT stage family, these linear stages exhibit enhanced motion performance over Aerotech's first generation ANT series.

Noncontact Direct-Drive

All of the original ANT series' direct-drive advantages have been preserved in the ANT95-L-Z family. Only noncontact direct-drive technology offers the robust, accurate, and high-speed positioning necessary for mass production of precision devices. ANT95-L-Z stages utilize advanced direct-drive technology pioneered by Aerotech to achieve the highest level of positioning performance for high-precision positioning, disk-drive fabrication, fiber alignment, optical delay element actuation, sensor testing, and scanning processes that demand smooth and precise motion.

The ANT95-L-Z stages use a nearly frictionless counterbalance mechanism to maintain performance levels while minimizing motor heating. The counterbalance is user-adjustable from 0 to 5 kg.

Flexible System Design

The ANT95-L-Z family has universal mounting and tabletop patterns that allow for easy system integration. Two, three, or

more axes can be easily combined for flexible system designs and multi-axis configurations.

System Characteristics

Outstanding accuracy, position repeatability, and in-position stability require high system resolution. The ANT95-L-Z stage's industry-leading 2 nm minimum incremental step size provides this high level of performance. Excellent in-position stability is assisted by high-quality, anti-creep, crossed-roller bearings. The stage offers virtually maintenance-free operation over the life of the product. Aerotech's direct-drive technology has no hysteresis or backlash, enabling accurate and repeatable nanometer-scale motion.

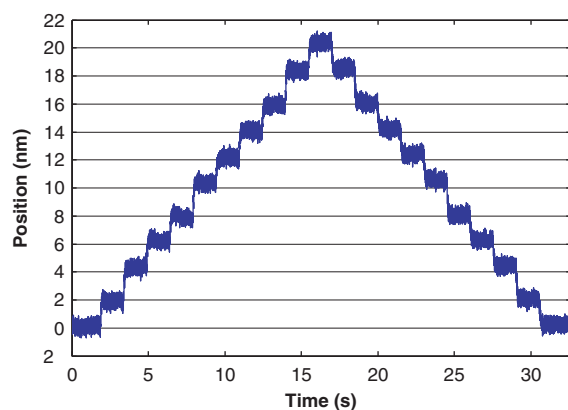

ANT95-50-L-Z-PLUS 2 nm step plot with 100 Hz filter. Best-in-class resolution and exceptional in-position stability for large travel stages.

ANT95-L-Z/ANT95-L-Z-PLUS Series SPECIFICATIONS

Mechanical Specifications	ANT95-25-L-Z	ANT95-25-L-Z-PLUS	ANT95-50-L-Z	ANT95-50-L-Z-PLUS
Travel	25 mm	25 mm	50 mm	50 mm
Accuracy ⁽¹⁾	±4.0 µm (±160 µin)	±300 nm (±12 µin)	±4.0 µm (±160 µin)	±300 nm (±12 µin)
Resolution	2 nm (0.08 µin)	2 nm (0.08 µin)	2 nm (0.08 µin)	2 nm (0.08 µin)
Repeatability (Bi-Directional) ⁽¹⁾	±100 nm (±4 µin)	±75 nm (±3 µin)	±100 nm (±4 µin)	±75 nm (±3 µin)
Repeatability (Uni-Directional)	±50 nm (±2 µin)	±50 nm (±2 µin)	±50 nm (±2 µin)	±50 nm (±2 µin)
Straightness ⁽¹⁾	±2.25 µm (±90 µin)	±2.25 µm (±90 µin)	±3.0 µm (±120 µin)	±3.0 µm (±120 µin)
Flatness ⁽¹⁾	±3.5 µm (±140 µin)	±3.5 µm (±140 µin)	±4.0 µm (±160 µin)	±4.0 µm (±160 µin)
Pitch	10 arc sec	10 arc sec	10 arc sec	10 arc sec
Roll	10 arc sec	10 arc sec	10 arc sec	10 arc sec
Yaw	5 arc sec	5 arc sec	5 arc sec	5 arc sec
Maximum Speed	200 mm/s (8 in/s)	200 mm/s (8 in/s)	200 mm/s (8 in/s)	200 mm/s (8 in/s)
Maximum Acceleration	1 g - 10 m/s ² (No Load)	1 g - 10 m/s ² (No Load)	1 g - 10 m/s ² (No Load)	1 g - 10 m/s ² (No Load)
In-Position Stability ⁽²⁾	<2 nm (<0.08 µin)	<2 nm (<0.08 µin)	<2 nm (<0.08 µin)	<2 nm (<0.08 µin)
Maximum Force (Continuous)	7.75 N	7.75 N	9.5 N	9.5 N
Load Capacity ⁽³⁾	Vertical	Vertical	Vertical	Vertical
	5.0 kg (11 lb)	5.0 kg (11 lb)	5.0 kg (11 lb)	5.0 kg (11 lb)
Moving Mass	0.46 kg (1.0 lb)	0.46 kg (1.0 lb)	0.52 kg (1.1 lb)	0.52 kg (1.1 lb)
Stage Mass	1.9 kg (4.3 lb)	1.9 kg (4.3 lb)	2.5 kg (5.5 lb)	2.5 kg (5.5 lb)
Material	Aluminum Body/Black Hardcoat Finish			
MTBF (Mean Time Between Failure)	30,000 Hours			

Notes:

- Certified with each stage.
 - In-Position Jitter listing is 3 sigma value.
 - Axis orientation for on-axis loading is listed.
 - Air supply must be clean, dry to 0Å°F dew point and filtered to 0.25 µm or better; recommend nitrogen at 99.9% purity. Supply pressure is determined by the amount of payload carried by the stage.
- Specifications are per axis, measured 25 mm above the tabletop. Performance of multi-axis systems is payload and workpoint dependent. Consult factory for multi-axis or non-standard applications.
 - PLUS requires the use of an Aerotech controller.

Electrical Specifications	ANT95-25-L-Z	ANT95-25-L-Z-PLUS	ANT95-50-L-Z	ANT95-50-L-Z-PLUS
Drive System	Brushless Linear Servomotor			
Feedback	Noncontact Linear Encoder			
Maximum Bus Voltage	±40 VDC			
Limit Switches	5 V, Normally Closed			
Home Switch	Near Center			

Recommended Controller	ANT95-25-L-Z	ANT95-25-L-Z-PLUS	ANT95-50-L-Z	ANT95-50-L-Z-PLUS
Multi-Axis	A3200	Npaq-MXR Npaq MR-MXH Ndrive ML-MXH		
	Ensemble	Epaq-MXH Epaq MR-MXH Ensemble ML-MXH		
Single Axis	Soloist	Soloist ML-MXH		

Notes:

- Linear amplifiers are required to achieve the listed specifications. Other options are available.

Note: To ensure the achievement and repeatability of specifications over an extended period of time, environmental temperature must be controlled to within 0.25°C/24 hours. If this is not possible, alternate products are available. Please consult Aerotech Application Engineering for more information.

ANT95-L-Z/ANT95-L-Z-PLUS Series PERFORMANCE

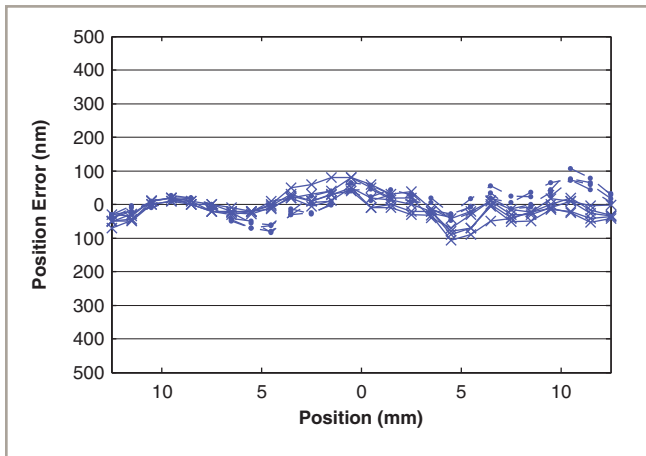

ANT95-25-L-Z-PLUS accuracy and repeatability. This multiple test run over an extended period of time shows the high level of system accuracy and repeatability.

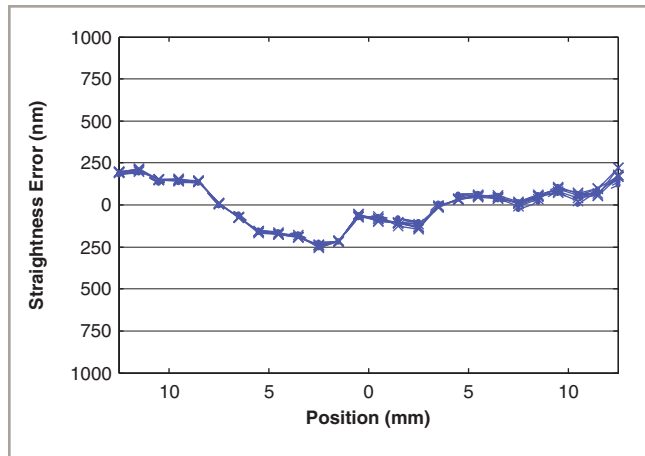

ANT95-25-L-Z-PLUS straightness error, five runs, bi-directional. Exceptional and highly repeatable – five times more accurate than the stated specification.

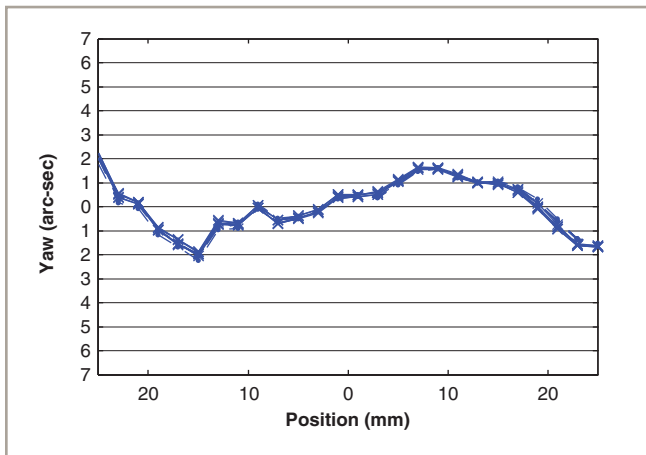

ANT95-50-L-Z-PLUS yaw, five runs, bi-directional. Highly repeatable, minimal yaw error enhances system positioning accuracy.

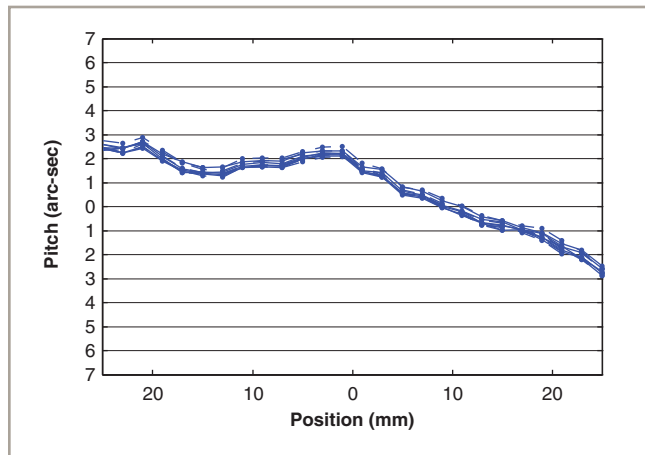

ANT95-50-L-Z-PLUS pitch, five runs, bi-directional. Excellent repeatability/accuracy contribute to improved processing.

ANT95-25-L-Z/ANT95-L-Z-PLUS DIMENSIONS

ANT95-25-L-Z/ANT95-25-L-Z-PLUS

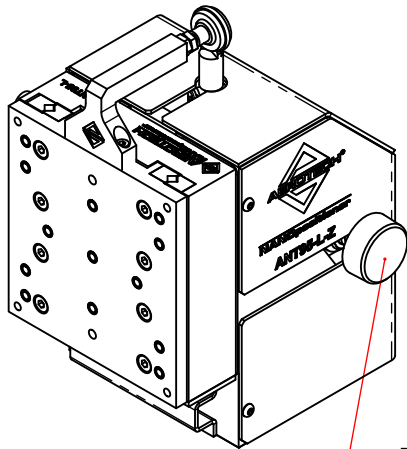
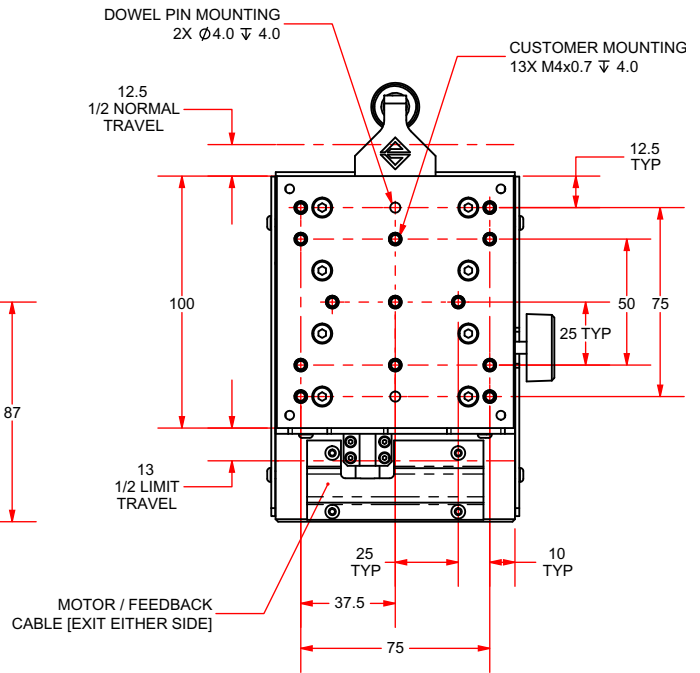
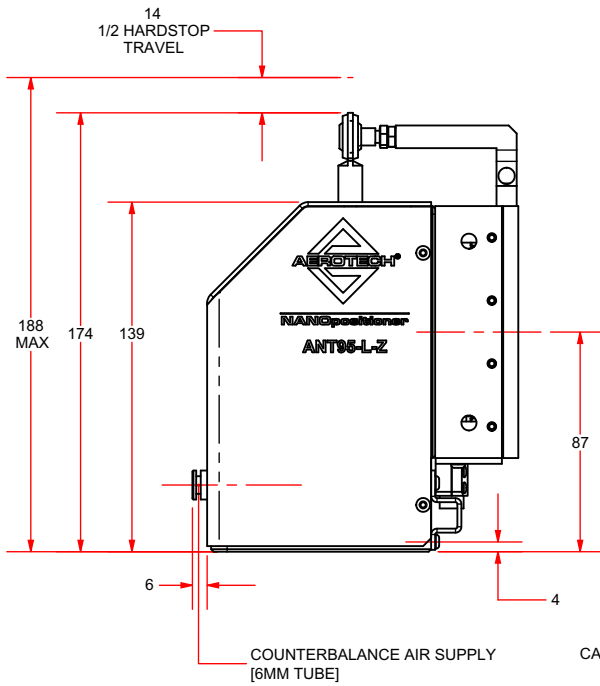

REGULATOR KNOB FOR COUNTERBALANCE ADJUSTMENT

STAGE MOUNTING
17X $\phi 4.8$ THRU ALL
[CLEARANCE FOR M4 SHCS]

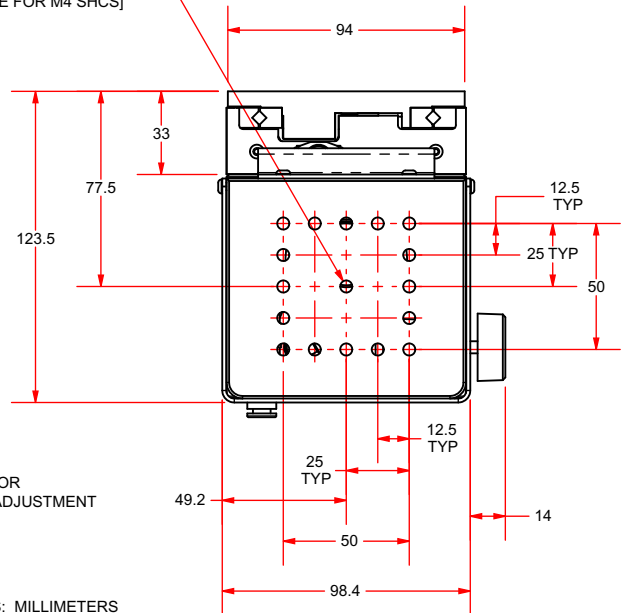

DIMENSIONS: MILLIMETERS

ANT95-50-L-Z/ANT95-50-L-Z-PLUS DIMENSIONS

ANT95-50-L-Z/ANT95-50-L-Z-PLUS

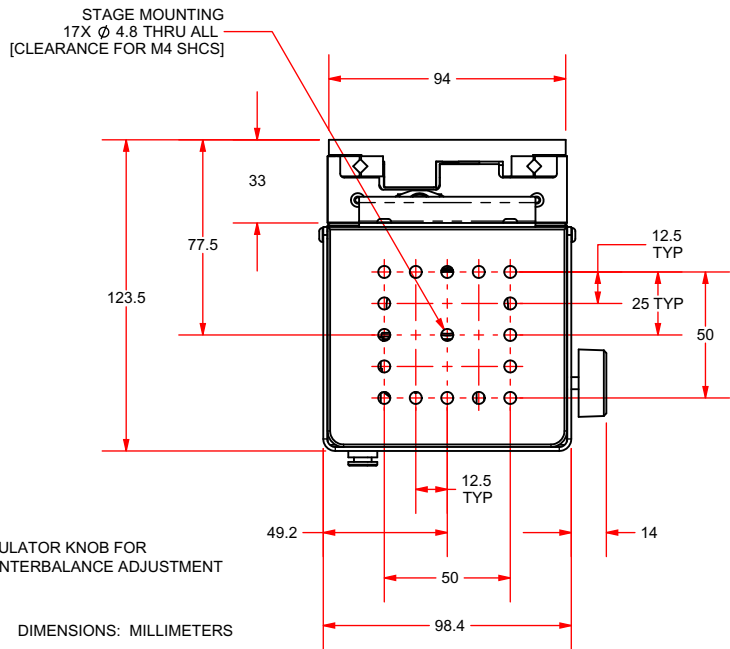
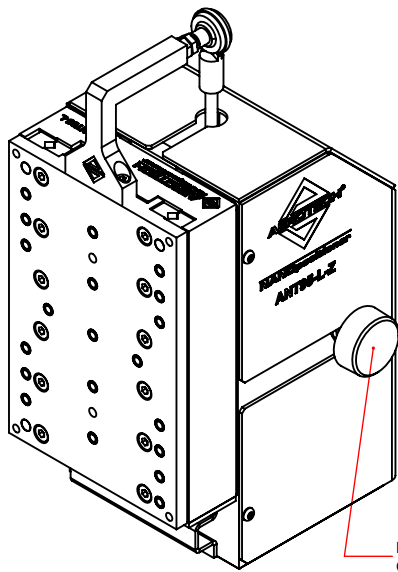
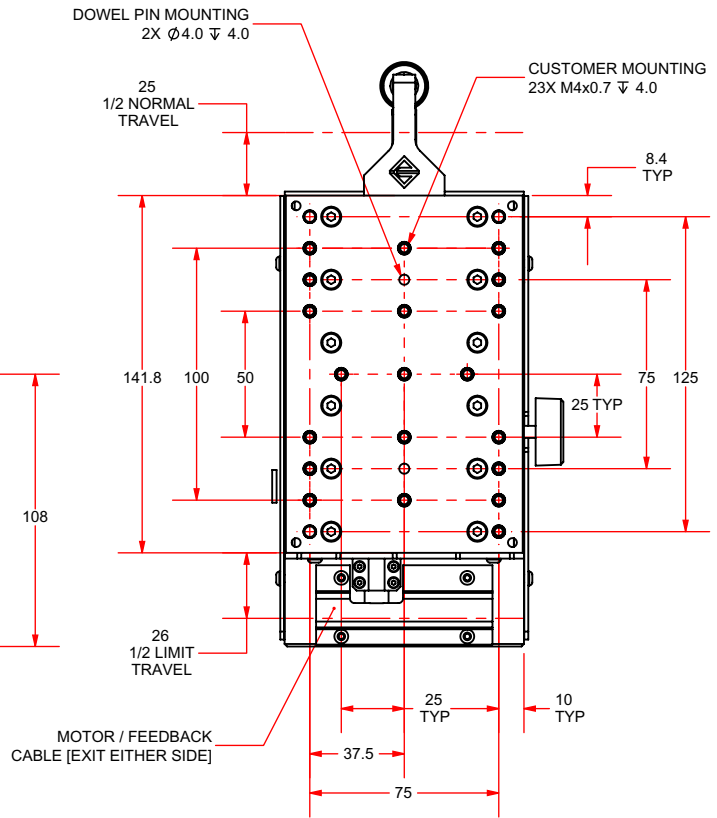
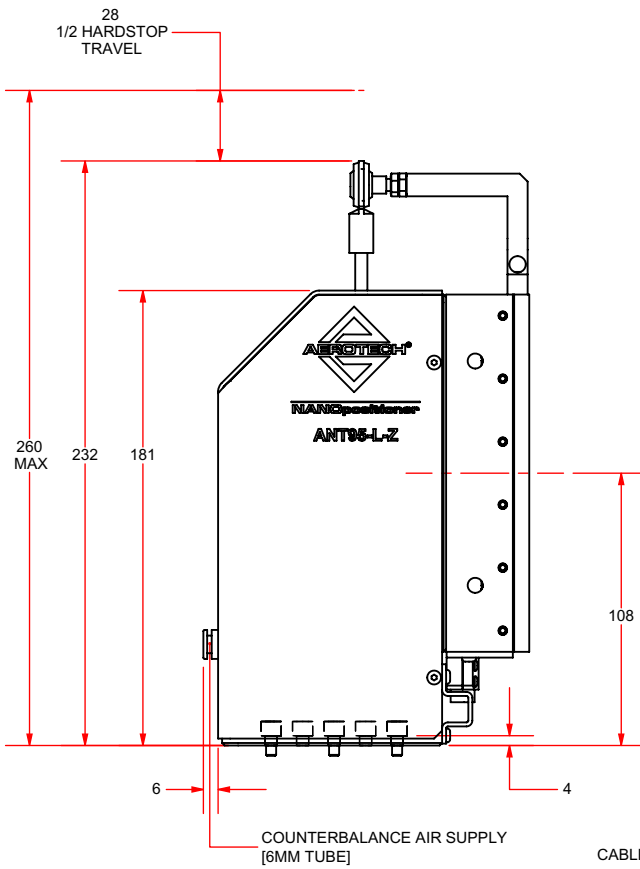

DIMENSIONS: MILLIMETERS

ANT95-L-Z/ANT95-L-Z-PLUS Series ORDERING INFORMATION

ANT95-L-Z Series Vertical Stage

ANT95-L-Z/ANT95-L-Z-PLUS Aerotech nanotranslation crossed-roller vertical positioner

Linear Stage Travel

ANT95-25-L-Z	25 mm (1 in) vertical travel stage with proprietary direct-drive motor technology, 1 Vp-p sinusoidal output linear encoder and limits
ANT95-25-L-Z-PLUS	25 mm (1 in) vertical travel stage with proprietary direct-drive motor technology, 1 Vp-p sinusoidal output linear encoder and limits (High Accuracy Version)
ANT95-50-L-Z	50 mm (2 in) vertical travel stage with proprietary direct-drive motor technology, 1 Vp-p sinusoidal output linear encoder and limits
ANT95-50-L-Z-PLUS	50 mm (2 in) vertical travel stage with proprietary direct-drive motor technology, 1 Vp-p sinusoidal output linear encoder and limits (High Accuracy Version)

Options

-RH	Right-hand cable exit
-LH	Left-hand cable exit