

Npaq® Series

Drive Racks

3U plug-in drives

19 inch rack-mount design

Flexible design provides the ability to drive brush, brushless, or stepper motors with the same amplifier

5 A to 30 A peak output current

PWM or linear amplifier

Integral power supplies

IEEE-1394 FireWire® interface

Digital current, velocity, and position loops for improved motion stability

Optional Ethernet for I/O expansion

Integrated encoder multiplier for higher throughput and reduced wiring

Encoder or resolver feedback

UL and CE approval

The Npaq® is a high-performance, 6-axis drive rack with field replaceable front-mounted drives. All versions are 3U in size, rack-mountable, and compatible with the Automation 3200 motion platform.

Featuring high-performance double-precision DSPs, the Npaq family performs both current loop and servo-loop closures digitally to assure the highest level of positioning accuracy and rate stability. It is this processing capability that allows the Npaq to provide loop closure rates up to 20 kHz and to handle both digital and analog I/O processing, data collection, laser firing, and encoder multiplication tasks in real time.



Npaq

Standard options for the Npaq family include integrated encoder multiplication, per-axis brake control logic, I/O expansion, and integrated emergency stop circuitry.

The Npaq uses plug-in amplifiers supporting both linear and PWM topologies to control brushless, DC brush, or stepper motor types at up to 320 VDC operating voltage and 30 A peak current capability. The Npaq contains two configurable power supply sections to support a variety of motors with different operating voltages. When only one motor voltage is required, the power supply sections are joined together for even higher power capability. The Npaq has a dedicated Ethernet port used to communicate with third-party I/O modules for increased I/O count applications.

The Npaq supports up to three axes of Position Synchronized Output (PSO) for precise synchronizing of external devices, over-voltage shunt controller, and external fans for high-power operation.

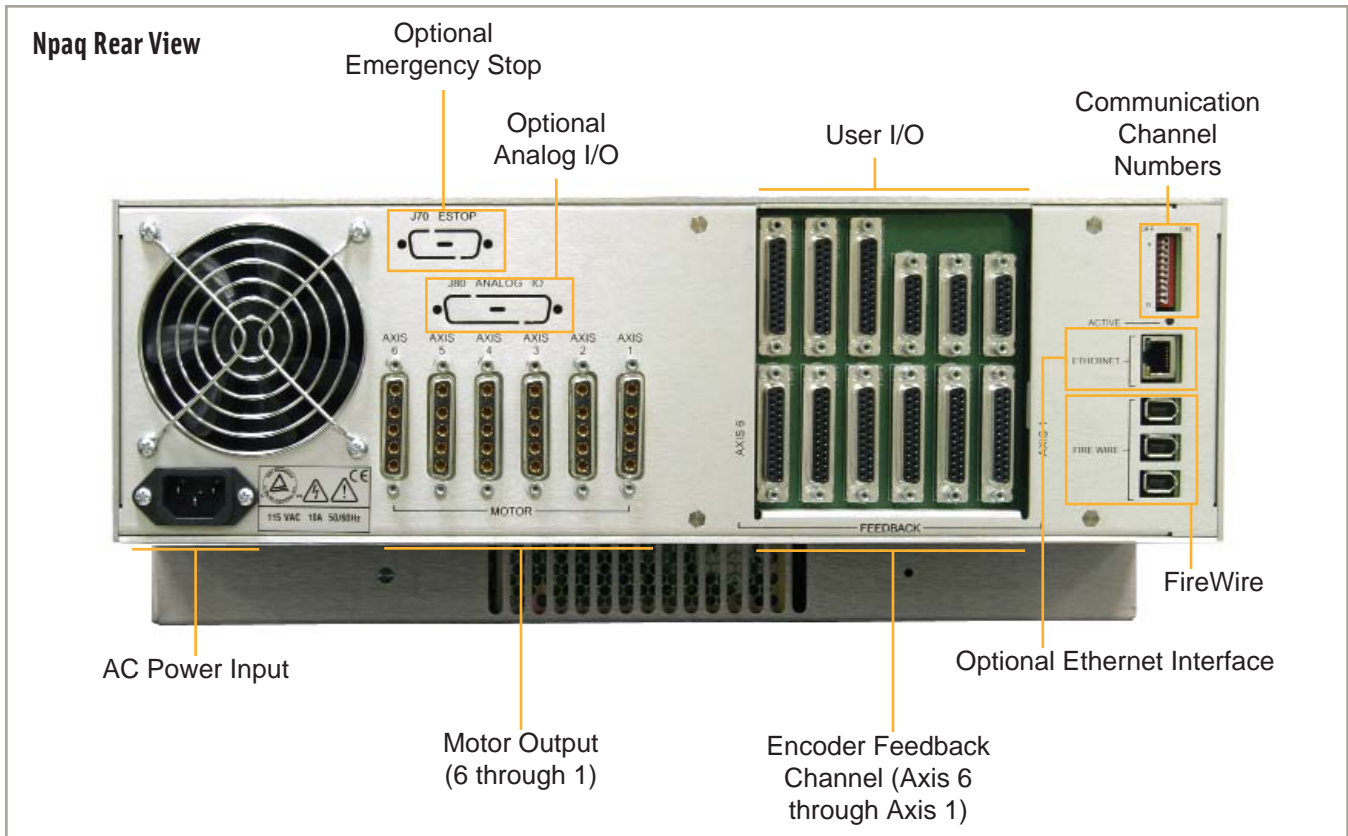

Plug-in drives
 Brush, brushless, or stepper
 PWM or linear
 Wide range of power



Amplifiers	DP32010E	DP32020E	DP32030E	DL4010
Control Type	Brushless, DC Brush, Stepper			
Output Type	PWM	PWM	PWM	Linear
Output Voltage (VDC)	10-320	10-320	10-320	10-40 (Bipolar)
Continuous Current	5	10	10	5 ⁽¹⁾
Peak Current	10	20	30	10 ⁽¹⁾
Minimum Load ⁽²⁾	0.1 mH	0.1 mH	0.1 mH	0 ohms
Protection	Short Circuit Protection; Overload Protection; Low Level Power Supply Detection and Fuse			
Switching Frequency	20 kHz	20 kHz	20 kHz	N/A

Notes:

1. Actual current ratings dependent on motor resistance

2. Minimum load is based on output voltage; 0.1 mH is minimum load at 160 VDC, 1.0 mH at 320 VDC

Npaq® Series SPECIFICATIONS

	Units	Npaq
Number of Axes		1 to 6
Encoder Inputs		1 to 6; Additional Through High Speed Input
Motor Style		Brush, Brushless, Stepper
Power Supply	VAC	Single-Phase 100-240 VAC; 50/60 Hz (Factory Configured)
Bus Voltage	VDC	10-320
Peak Output Current (1 sec) ⁽¹⁾	A _{pk}	10, 20, 30
Continuous Output Current ⁽¹⁾	A _{pk}	5, 10, 10
Digital Inputs	—	Eight Optically-Isolated
Digital Outputs	—	Eight Optically-Isolated
Analog Inputs	—	Four 16-bit Differential; ±1 V to ±10 V
Analog Outputs	—	Two 16-bit Single-Ended; ±10 V
Dedicated Axis I/O on Feedback Connector		Three Limit Inputs (CW, CCW, Home); Three Hall Effect Inputs (A, B, C); Three High-Speed Differential Inputs (sin, cos, mkr for encoder); Motor Over-Temperature Input
Dedicated I/O on Auxiliary Feedback Connector		N/A
I/O Expansion Board ⁽²⁾	—	Four Analog Input; Six Analog Output
High Speed Data Capture		Four Differential Inputs (1 μs Response Time)
High Speed Digital Outputs		Six Differential Outputs
Bi-Directional Lines		3
Automatic Brake Control	—	Optional
Emergency Stop (ESTOP)	—	Optional
Position Synchronized Output (PSO)	—	Single Axis Standard, Two/Three Axis Optional
Can Output Multiplied Encoder		Yes
Can Output Square Wave Encoder		Yes
Primary Encoder Input Frequency with Multiplication		450 kHz or 2 MHz sine wave (MXH)
Primary Encoder Input Frequency – Square Wave		10 MHz Square Wave Frequency/40 MHz Count Rate
Secondary Encoder Input Frequency		10 MHz Square Wave Frequency/40 MHz Count Rate
Laser Feedback Support		Yes
Encoder Multiplication ⁽³⁾	—	Up to x65536 With Quadrature Output (MXR)
Resolver Interface	—	Optional; 16-bit
Internal Shunt Resistor		40 W Continuous; 400 W Peak (5 seconds)
External Shunt		Optional
Ethernet	—	Optional
USB		No
RS-232		No
FireWire		Yes
Fieldbus		Modbus TCP on PC
Joystick Support		Yes
Current Loop Update Rate	kHz	20
Servo Loop Update Rate	kHz	8
Power Amplifier Bandwidth	kHz	Selectable Through Software
Minimum Load Inductance	mH	0.1 mH with PWM; 0 With Linear
Operating Temperature	°C	0 to 50
Storage Temperature	°C	-30 to 85
Weight	kg (lb)	24 (55)
Package		Slice Amplifier Installed in Front

Notes:

1. Peak value of the sine wave; rms current for AC motors is $0.707 * A_{pk}$.
2. Requires I/O option.
3. Effective resolution after quadrature decoding if applicable.

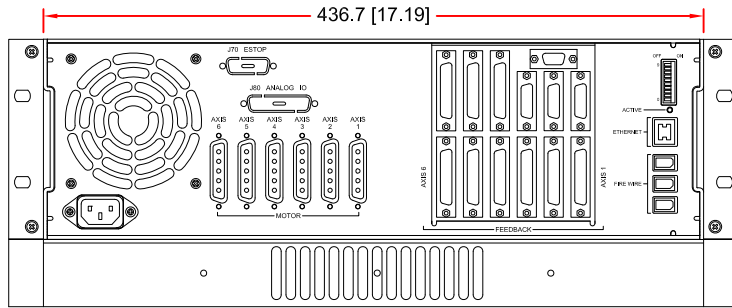

REAR VIEW ROTATED 180°

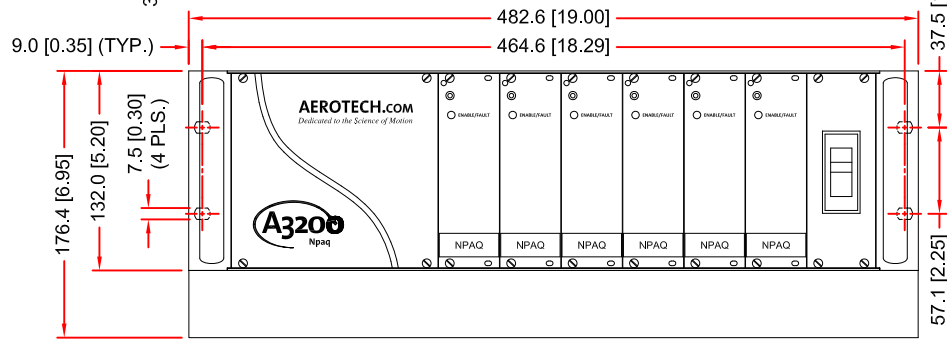
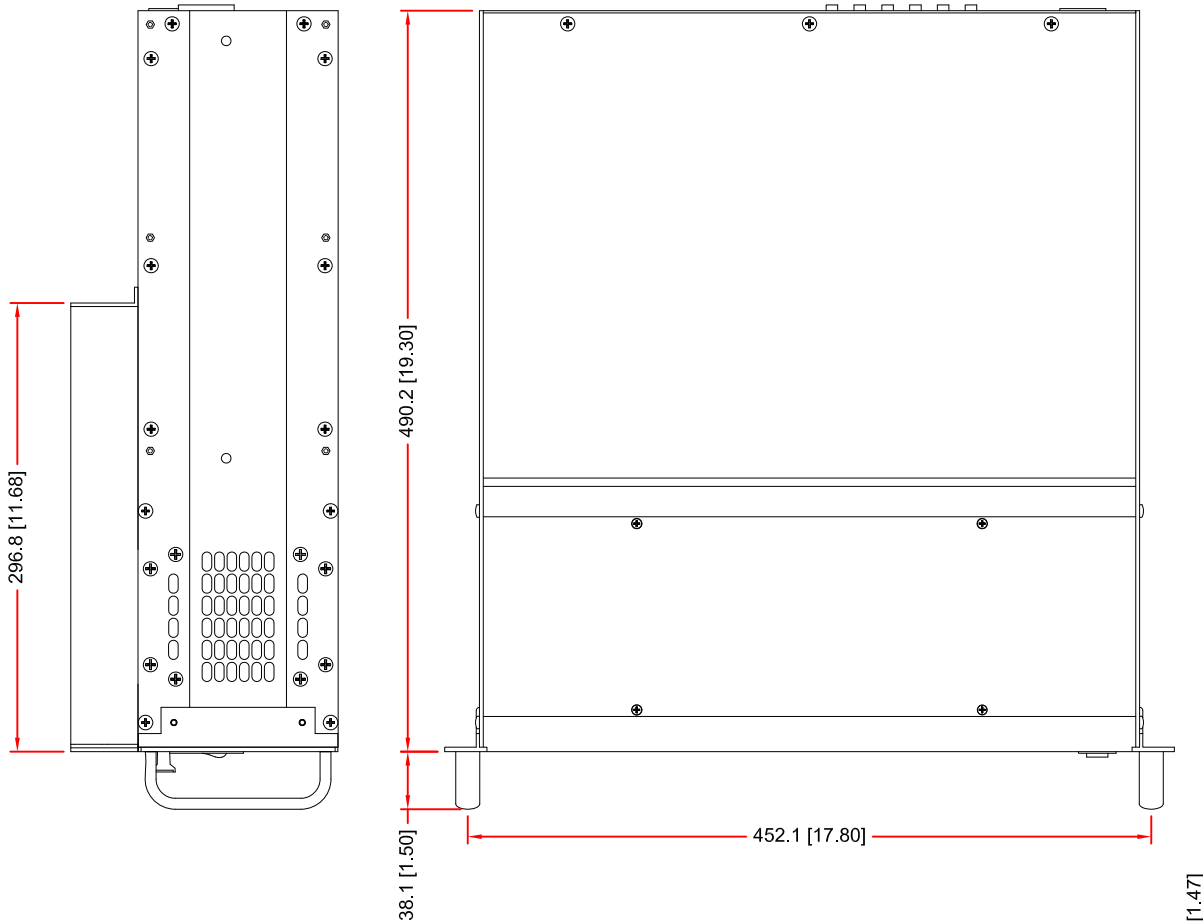

NPAQ WITH FAN TRAY OPTION

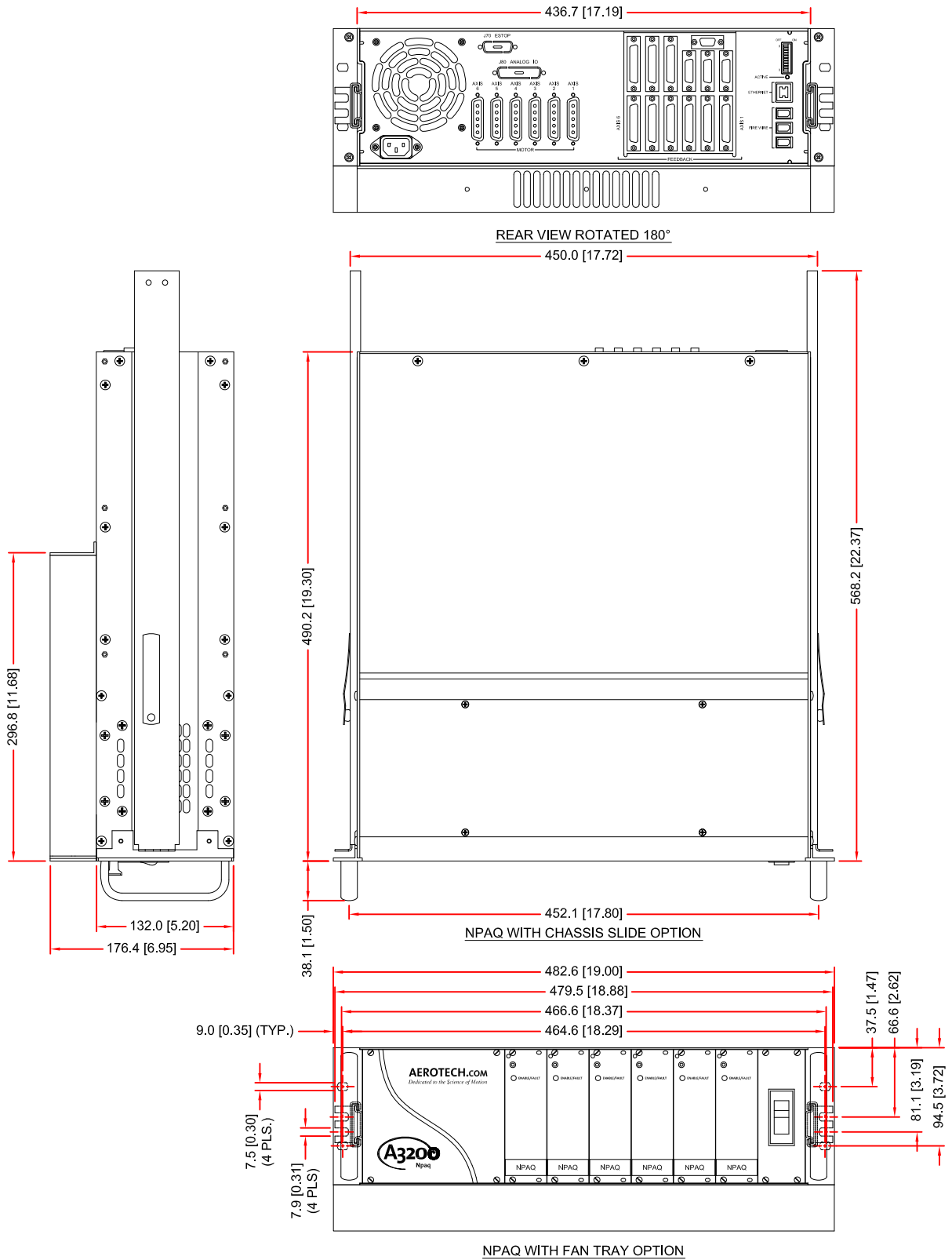

Npaq® Series ORDERING INFORMATION

Ordering Example: Required

Npaq	-A	-10B	-0	-ULTRA	/1-DL4010	/NO SPLIT	/STAND
Base	Power Input	Vbus1	Vbus2	Controller Options	Amp1-6	Split Bus	Cooling
	-A	-0	-0	-ULTRA	/DL4010	/Split Bus 1/2-6	/STAND
	-B	-10B	-10B		/DP32010E	/Split Bus 1-2/3-6	/EXT
	-C	-20B	-20B		/DP32020E	/Split Bus 1-3/4-6	/FAN
	-D	-30B	-30B		/DP32030E	/Split Bus 1-4/5-6	
		-40B	-40B		/BLANK	/Split Bus 1-5/6	
		-80B	-80B			/Split Bus 1-6	
		-160LT	-160LT				
		-320LT	-320LT				

/US-115VAC	/SLIDES	/BRAKE-z	/AC LINE FILTER	/ENET	/SINGLEPSO	/MXR-1	/M1
Line Cord	Mounting Options	Brake	Line Filter	Options	PSO Options	Encoder Multiplier Options	Motor Output
/ENGLAND	/STANDARD	/BRAKE-z	/AC LINE FILTER	/ENET	/SINGLEPSO	/MXR-1	/M1
/GERMANY	/SLIDES	/BRAKEIO		/ESTOP1	/DUALPSO	/MXR-2	/M2
/ISRAEL				/ESTOP2	/TRIPLEPSO	/MXR-3	/M3
/INDIA				/ESTOP3	/PSO-NC	/MXR-4	/M4
/AUSTRALIA				/LINESEL		/MXR-5	/M5
/US-115VAC				/LINESEL-MX		/MXR-6	/M6
/US-230VAC				/S160-1		/MXR2M-1	
/NO-LINECORD				/S160-2		/MXR2M-2	
				/S320-1		/MXR2M-3	
				/S320-2		/MXR2M-4	
				/AIO		/MXR2M-5	
						/MXR2M-6	

Npaq

Rack-mount digital amplifier chassis with integral DC power supply and FireWire® interface. Supports up to 6 axes of brush, brushless, or stepper motor amplifiers. Includes:

- 8 opto-isolated digital inputs
- 8 opto-isolated digital outputs
- 4 16-bit differential analog inputs
- 2 16-bit analog outputs
- 6 channels of 40 MHz quadrature encoder input (analog input optional)

Power Input (Required)

-A	115 VAC
-B	230 VAC
-C	100 VAC
-D	208 VAC

Bus Voltage (Vbus1) (Required) Configures the bus voltage for Vbus1

0	Not wired
-10B	±10 VDC (200 W power supply), bipolar
-20B	±20 VDC (200 W power supply), bipolar
-30B	±30 VDC (200 W power supply), bipolar
-40B	±40 VDC (300 W power supply), bipolar
-80B	±80 VDC (300 W power supply), bipolar
-160LT	160 VDC (does not include transformer), unipolar, used with DP320XX
-320LT	320 VDC (does not include transformer), unipolar, used with DP320XX

Npaq® Series ORDERING INFORMATION

Bus Voltage (Vbus2) (Required) Configures the bus voltage for Vbus2

-0	Not wired
-10B	±10 VDC (200 W power supply), bipolar
-20B	±20 VDC (200 W power supply), bipolar
-30B	±30 VDC (200 W power supply), bipolar
-40B	±40 VDC (300 W power supply), bipolar
-80B	±80 VDC (300 W power supply), bipolar
-160LT	160 VDC (does not include transformer), unipolar, used with DP320XX
-320LT	320 VDC (does not include transformer), unipolar, used with DP320XX

Controller Options (Required)

-ULTRA	6 axis control board
--------	----------------------

Npaq Amplifiers (Required)

/DP32010E	Brushless motor driver, 320 V, 5 A cont., 10 A peak, 20 kHz PWM, 3U height, enhanced resolution, requires A3200 software version 2.13 or greater
/DP32020E	Brushless motor driver, 320 V, 10 A cont., 20 A peak, 20 kHz PWM, 3U height, enhanced resolution, requires A3200 software version 2.13 or greater
/DP32030E	Brushless motor driver, 320 V, 15 A cont., 30 A peak, 20 kHz PWM, 3U height, enhanced resolution, requires A3200 software version 2.13 or greater
/DL4010	Brushless motor driver, ±40 V, 5 A cont., 10 A peak, linear DC, 3U height; actual current depends on motor parameters

Split Bus (Required)

/SPLIT BUS 1/2-6	Axis 1 Vbus1; Axis 2-6 Vbus2
/SPLIT BUS 1-2/3-6	Axis 1-2 Vbus1; Axis 3-6 Vbus2
/SPLIT BUS 1-3/4-6	Axis 1-3 Vbus1; Axis 4-6 Vbus2
/SPLIT BUS 1-4/5-6	Axis 1-4 Vbus1; Axis 5-6 Vbus2
/SPLIT BUS 1-5/6	Axis 1-5 Vbus1; Axis 6 Vbus2
/SPLIT BUS 1-6 (NO SPLIT)	Axis 1-6 Vbus1

Cooling Options (Required)

/STAND	Built-in fan pulls cooling air from left side through the amplifier compartment
/EXT	Perforated covers above and below the amplifiers; requires external fan tray for cooling (customer supplied)
/FAN	Perforated covers above and below the amplifiers; includes 1U-high fan tray for cooling; fans wired to the Npaq power switch

Linecord (Required)

/ENGLAND	UK compatible line cord
/GERMAN	German compatible line cord
/ISRAEL	Israel compatible line cord
/INDIA	India compatible line cord
/AUSTRALIA	Australia compatible line cord
/US-115VAC	US 115 VAC line cord
/US-230VAC	US 230 VAC line cord
/NO-LINECORD	No line cord

Mounting Options (Required)

/STANDARD	Rack mount
/SLIDES	Rack-mounted drawer slides

Brake Options (Optional)

/BRAKE-z	Brake control logic and power supply; specify which axis "z" as 1, 2, 3, 4, 5 or 6
/BRAKEIO	Brake control logic and power supply; brake signal wired to miscellaneous I/O connector

Line Filter (Optional)

/AC LINE FILTER	AC line filter for reducing conducted emissions; required for CE
-----------------	--

Npaq® Series ORDERING INFORMATION

Options

/ENET	10/100 BASE-T Ethernet port
/ESTOP1	Controller stops motion, then disables servo control. Internal positive guided relay with monitor contact disconnects AC power source from motor. Operator risk assessment is the responsibility of the end user or integrator
/ESTOP2	Same as ESTOP1 but uses two relays
/ESTOP3	Same as ESTOP2 but contains 1 second bus discharge resistors
/LINESEL	User selectable input voltages
/LINESEL-MX	User selectable input voltages; for MXR option
/S160-1	Shunt for Vbus1; 160 VDC operation
/S160-2	Shunt for Vbus2; 160 VDC operation
Note: Both shunts permitted for 160 VDC option.	
/S320-1	Shunt for Vbus1; 320 VDC operation
/S320-2	Shunt for Vbus2; 320 VDC operation
Note: Only one shunt permitted for 320 VDC option.	
/AIO	Analog I/O option; adds an additional four 16-bit analog inputs and six 16-bit analog outputs
Note: High speed digital I/O not available when selecting this option.	

PSO Options (Optional)

/SINGLEPSO	Single axis PSO
/DUALPSO	Dual axis PSO
/TRIPLEPSO	Triple axis PSO
/PSO-NC	PSO output signal is normally closed; output is open when PSO is active

Encoder Multiplier Options (Optional)

/MXR-1	x65536 multiplier for axis 1, 450 kHz input, real-time output for PSO operation (programmable resolution)
/MXR-2	x65536 multiplier for axes 1-2, 450 kHz input, real-time output for PSO operation (programmable resolution)
/MXR-3	x65536 multiplier for axes 1-3, 450 kHz input, real-time output for PSO operation (programmable resolution)
/MXR-4	x65536 multiplier for axes 1-4, 450 kHz input, real-time output for PSO operation (programmable resolution), 3 axes max
/MXR-5	x65536 multiplier for axes 1-5, 450 kHz input, real-time output for PSO operation (programmable resolution), 3 axes max
/MXR-6	x65536 multiplier for axes 1-6, 450 kHz input, real-time output for PSO operation (programmable resolution), 3 axes max
/MXR2M-1	x65536 multiplier for axis 1, 2 MHz input, real-time output for PSO operation (programmable resolution)
/MXR2M-2	x65536 multiplier for axes 1-2, 2 MHz input, real-time output for PSO operation (programmable resolution)
/MXR2M-3	x65536 multiplier for axes 1-3, 2 MHz input, real-time output for PSO operation (programmable resolution)
/MXR2M-4	x65536 multiplier for axes 1-4, 2 MHz input, real-time output for PSO operation (programmable resolution), 3 axes max
/MXR2M-5	x65536 multiplier for axes 1-5, 2 MHz input, real-time output for PSO operation (programmable resolution), 3 axes max
/MXR2M-6	x65536 multiplier for axes 1-6, 2 MHz input, real-time output for PSO operation (programmable resolution), 3 axes max
Note: Effective multiplication factor specified after quadrature decoding (if applicable).	

Motor Output (Required)

/M1	Axis 1 motor output wiring installed
/M2	Axes 1-2 motor output wiring installed
/M3	Axes 1-3 motor output wiring installed
/M4	Axes 1-4 motor output wiring installed
/M5	Axes 1-5 motor output wiring installed
/M6	Axes 1-6 motor output wiring installed
Note: Must be greater than or equal to the number of amplifiers in the system.	

Resolver (Optional)

/RDP2-y	1-2 axis RD converter board; must be on axis 1-2
/RDP4-y	1-4 axis RD converter board; must be on axis 1-4
/RDP6-y	1-6 axis RD converter board
Note: Where y is the carrier frequency. Options are 5, 7.5, or 10 kHz.	

Accessories (Optional)

/JI	4-way industrial joystick sealed for harsh environments; includes 1.5 m (5 ft) cable and three dedicated function buttons
/JBV	Joystick with 5 ft cable