

Planar_{HD}

Air Bearing, Linear Motor Stage

Maximize throughput with 2 m/s scan velocity and 5 g acceleration

Faster turnaround and minimized settling times

Active yaw control

Linear encoder or laser interferometer feedback

Travel to 1.2 m x 1.2 m

Aerotech has a long history of engineering and manufacturing the world's highest performance motion systems to directly address our customers' key application needs. These efforts have helped to enable key technologies in a multitude of industries including semiconductor, medical, and military/aerospace. This extensive history and experience have culminated in the development of the Planar_{HD} "high dynamic" air-bearing motion platform. Every component and design feature has been selected to provide the highest possible dynamic performance for applications requiring extremely high throughput while maintaining very tight geometric characteristics.

Planar_{HD} Design Features

The Planar_{HD} air-bearing stage has been designed specifically to maximize throughput by providing up to 2 m/s scan velocity and 5 g acceleration. The design utilizes a highly engineered mechanical structure that increases air-bearing stiffness and decreases moving mass. In addition, the locations of the center of force and the center of mass have been optimized to eliminate parasitic forces that can result in throughput reducing error motions.

To further enhance stage performance, the Planar_{HD} uses air-on-air lateral preload on both the X and Y axes. This preload method uses opposing positive-pressure air films to balance the bearing lift and preload forces. The dynamic bearing force balancing method gives the Planar_{HD} maximum stiffness, which provides faster turnaround and minimal settling time.

Unlike monolithic L-designs that rely on only a single vacuum preloaded gantry axis, the Aerotech gantry axis is a dual air-bearing H-bridge design that incorporates dual linear motors and dual linear encoders. This further improves turnaround performance while providing the added benefit of orthogonality/yaw control. Faster turns means higher



throughput and smaller stage footprint, while orthogonality control means that process swaths are parallel over the entire wafer surface.

Feedback System

Both linear encoder and laser interferometer options are available. The Planar_{HD} incorporates three high-accuracy linear encoders, one for the bridge axis and two for the gantry axis, as standard. Each encoder is mounted so that the scale centerline is as close to the working plane as possible to reduce Abbe errors. Both encoder materials and mounting methods have been chosen to specifically address thermal-induced accuracy errors.

Drive System

A key to Planar_{HD} performance is the use of Aerotech's BLM series brushless linear servomotors. The BLM series linear motors utilize an ironlessforcer that provides zero cogging motion with no attractive forces, resulting in extremely smooth motion. In addition, BLM series linear motors generate the highest force per unit volume of any competitive motor design. The Planar_{HD} also includes both air and water cooling thermal management options.

Advanced Control Architecture

The Planar_{HD} is coupled to Aerotech's advanced Automation 3200 control system. The Automation 3200 is a 100% digital system with high performance FireWire® networked drives. The fully digital architecture makes it possible to optimize the current, velocity, and position servo loops for maximum performance. Advanced trajectory generation capabilities, such as multi-block look-ahead, minimize geometry errors during fast turnaround, while our Position Synchronized Laser Firing Output (PSO) functionality automatically adjusts the laser pulse frequency to match the stage speed to maintain optimal system performance.

Basic Model		Planar _{HD}
Travel	Scan Axis	500 mm
	Step Axis	500 mm
Drive System		Linear Brushless Servomotor (Scan Axis: BLM-264-A) (Step Axis: Two BLM-325-A)
Resolution		0.25 nm
Accuracy (Zero Expansion Scale) ⁽¹⁾		±300 nm
Repeatability (Long Term)		±50 nm
XYZ Position Stability (On Air)		20 nm
Granite Base Thickness		250 mm
Rated Payload (Maintaining Dynamic Specifications)		5 kg
Maximum Payload ⁽²⁾		30 kg
Maximum Velocity with Rated Payload ⁽³⁾	Scan Axis	2000 mm/s
	Step Axis	
Peak Acceleration with Rated Payload	Scan Axis	5 g (50 m/s ²)
	Step Axis	
RMS Acceleration with Rated Payload	Scan Axis	1.25 g (12 m/s ²)
	Step Axis	
Stiffness, First Natural Frequency, Rated Payload		>330 Hz
Pitch		2 arc sec
Roll		2 arc sec
Yaw		2 arc sec
XY Orthogonality ⁽⁴⁾		1 arc sec
MTBF		>40,000 hours

Notes:

1. Available with Aerotech controllers and HALAR calibration option.
2. Maximum load based on bearing capability; maximum application load may be limited by acceleration requirements.
3. Maximum speed based on stage capability; maximum application velocity may be limited by system data rate and system resolution.
4. Requires calibration.
5. To protect air bearing against under-pressure, an in-line pressure switch tied to motion controller E-stop input is recommended.
6. Air supply must be clean, dry to 0° F dewpoint and filtered to 0.25 µm or better; recommend nitrogen at 99.9% purity.
7. Optional construction materials include ceramic, invar, stainless, and titanium.

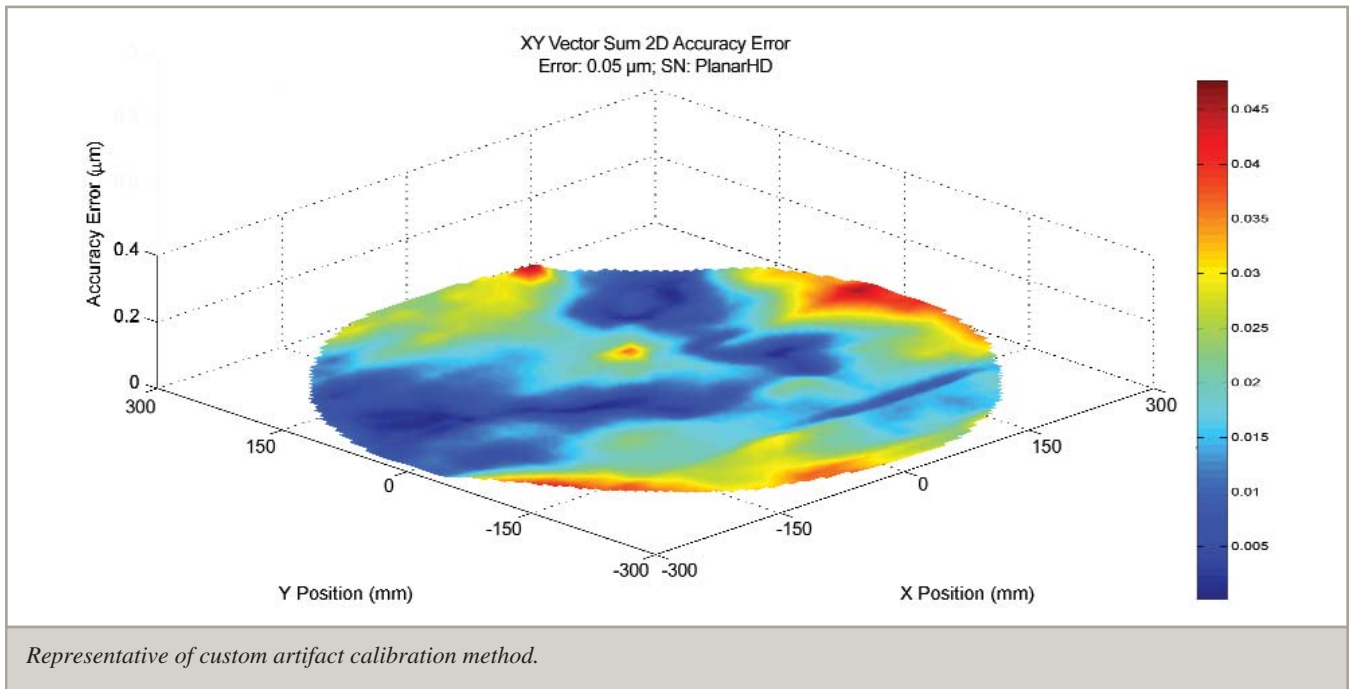

STAGE	A	B	C	D
PLANAR HD-350-350	350	350	1345	1116
PLANAR HD-350-500	350	500	1345	1266
PLANAR HD-350-650	350	650	1345	1416
PLANAR HD-500-350	500	350	1495	1116
PLANAR HD-500-500	500	500	1495	1266
PLANAR HD-500-650	500	650	1495	1416
PLANAR HD-650-350	650	350	1645	1116
PLANAR HD-650-500	650	500	1645	1266
PLANAR HD-650-650	650	650	1645	1416

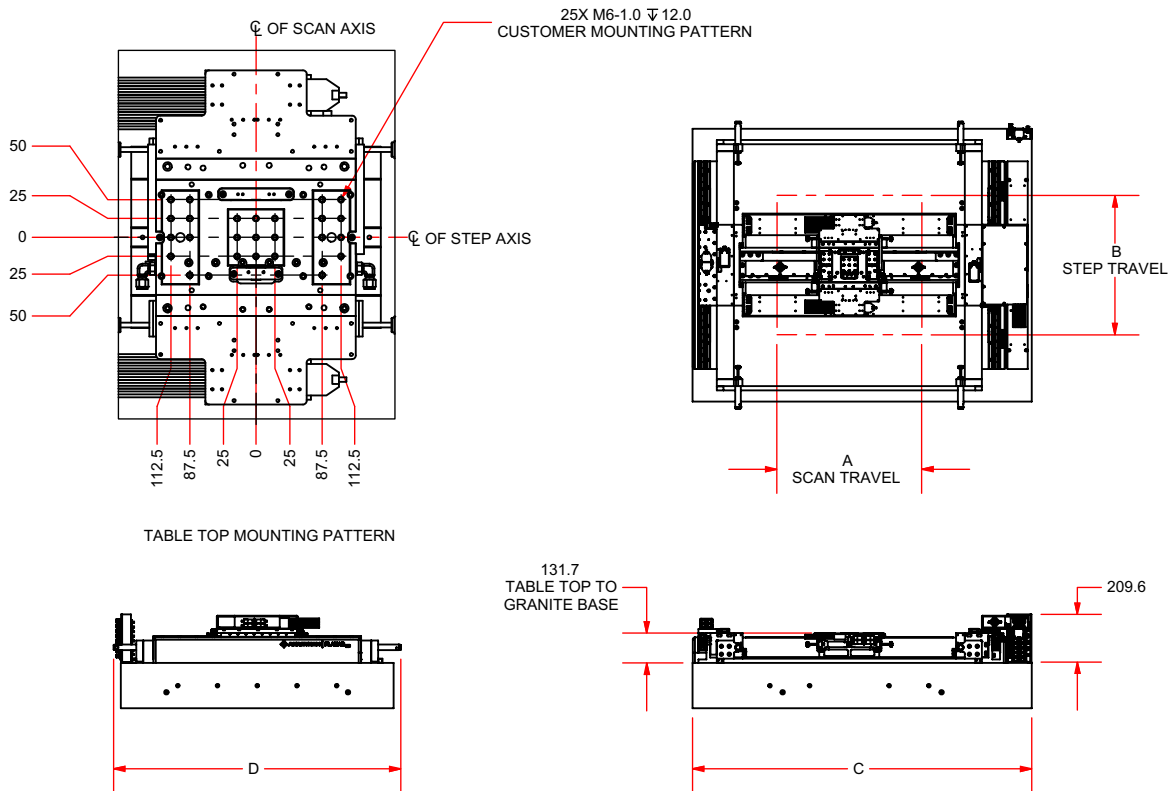

DIMENSIONS: MILLIMETERS