

# ALS20000 Series

## Mechanical Bearing, Linear Motor Stage

Protective metal waycover

Integral cable management system

Ideally suited for clean-room applications

Compact, high-performance, linear motor stage

Superior velocity control for imaging and scanning applications



The ALS20000 was designed to have exceptional velocity control, low vibration, high accuracy, and excellent throughput, making it the ideal solution for imaging and precision inspection applications.

### High Performance in a Compact Package

ALS20000 series stages incorporate the highest quality materials and design elements. The result is a high-reliability linear stage with excellent accuracy, straightness and flatness performance, and a virtually unlimited, trouble-free service life.

Recognizing the importance of stage stiffness, the ALS20000 linear bearings are supported by the maximum cross-section possible while still maintaining an overall low profile. Outstanding system straightness and flatness are obtained particularly in XY configurations.

### Linear Motor Drive

Unlike other linear motor stage designs that utilize an iron-core flat motor design, the ALS20000 is driven by a high-power ironless forcer and U-channel magnet track. This design is superior in high-performance applications.

Since the BLM is ironless, it is a cog-free design. The lack of cogging enables extremely tight velocity control as well as superior contour motion profiles without sacrificing speed or acceleration.

The magnetic field of the BLM motor is totally self-contained within the U-channel design. Most high-performance applications cannot tolerate the stray magnetic fields generated by flat motor magnet tracks.

The BLM's magnet track is composed of opposing rows of high-power magnets that help to generate high output forces. This approach eliminates the need for an iron-based core, which has an inherent magnetic attraction between the forcer and the magnet track. This attractive force presents an additional load to the bearings that reduces stage life and performance.

### Cable Management System

Extensive R&D has resulted in an optimized cable management system (CMS) that is designed for millions of cycles of maintenance-free operation. Designed to provide a turnkey system for both single- and multi-axis systems, upper-axis cabling is incorporated into the overall system CMS. To facilitate integration into the final system, a spare 25-pin D-connector and cabling are included for customer use. Custom configurations are common and are readily available.

## ALS20000 Series SPECIFICATIONS

Basic Model		ALS20010	ALS20020	ALS20030	
Total Travel		100 mm (4 in)	200 mm (8 in)	300 mm (12 in)	
Drive System		Linear Brushless Servomotor (BLM-142-A)			
Bus Voltage <sup>(1)</sup>		Up to 160 VDC			
Continuous Current <sup>(2)</sup>	A <sub>pk</sub>	Up to 3.10 A			
	A <sub>rms</sub>	Up to 2.19 A			
Feedback		Noncontact Linear Encoder			
Resolution	LN	0.001 μm - 0.2 μm (0.04 μin - 8 μin)			
	LT	0.005 μm - 1.0 μm (0.2 μin - 40 μin)			
Maximum Travel Speed <sup>(3)</sup>		2 m/s (80 in/s)			
Maximum Linear Acceleration		3 g (30 m/s <sup>2</sup> ) (1152 in/s <sup>2</sup> ) (No Load)			
Maximum Load <sup>(4)</sup>	Horizontal	70.0 kg (154.3 lb)			
	Side	35.0 kg (77.2 lb)			
Accuracy	LN	HALAR <sup>(5)</sup>	±1.0 μm (±40 μin)		
		Standard	±5.0 μm (±200 μin)		
	LT	HALAR <sup>(5)</sup>	±1.0 μm (±40 μin)		
		Standard	±4.0 μm (±160 μin)	±8.0 μm (±320 μin)	±12.0 μm (±480 μin)
Repeatability	LN	±0.5 μm (±20 μin)			
	LT	±0.5 μm (±20 μin)			
Straightness and Flatness	Differential	HALSF	1 μm/25 mm (40 μin/in)		
		Standard	2 μm/25 mm (80 μin/in)		
	Maximum Deviation	HALSF	±1.0 μm (±40 μin)	±1.5 μm (±60 μin)	±2.0 μm (±80 μin)
		Standard	±2.0 μm (±80 μin)	±4.0 μm (±160 μin)	±6.0 μm (±240 μin)
Pitch and Yaw		5 arc sec	8 arc sec	12 arc sec	
Nominal Stage Weight		13.5 kg (29.8 lb)	17.5 kg (38.6 lb)	21.0 kg (46.3 lb)	
Moving Mass		6.1 kg (13.4 lb)			
Construction		Aluminum Body/Black Anodize Finish/Hardcoat (62 Rockwell Hardness Teflon® Impregnated)			

**Notes:**

- 80 VDC bus limit with standard ribbon cable. Up to 320 VDC is available with round cables.
- Current values based on high performance (-P) magnet track.
- Maximum speed based on stage capability. Maximum application velocity may be limited by system data rate and system resolution.
- Maximum load based on bearing capability. Maximum application load may be limited by acceleration requirements.
- Available with Aerotech controllers.
- Specifications are for single-axis systems, measured 50 mm above the tabletop. Performance of multi-axis systems is payload and workpoint dependent. Consult factory for multi-axis or non-standard applications.



# ALS20000 Series SPECIFICATIONS

Basic Model		ALS20035	ALS20045	ALS20060	
Total Travel		350 mm (14 in)	450 mm (18 in)	600 mm (24 in)	
Drive System		Linear Brushless Servomotor (BLM-142-A)			
Bus Voltage <sup>(1)</sup>		Up to 160 VDC			
Continuous Current <sup>(2)</sup>	A <sub>pk</sub>	Up to 3.10 A			
	A <sub>rms</sub>	Up to 2.19 A			
Feedback		Noncontact Linear Encoder			
Resolution	LN	0.001 μm - 0.2 μm (0.04 μin - 8 μin)			
	LT	0.005 μm - 1.0 μm (0.2 μin - 40 μin)			
Maximum Travel Speed <sup>(3)</sup>		2 m/s (80 in/s)			
Maximum Linear Acceleration		3 g (30 m/s <sup>2</sup> ) (1152 in/s <sup>2</sup> ) (No Load)			
Maximum Load <sup>(4)</sup>	Horizontal	70.0 kg (154.3 lb)			
	Side	35.0 kg (77.2 lb)			
Accuracy	LN	HALAR <sup>(5)</sup>	±1.0 μm (±40 μin)		
		Standard	±5.0 μm (±200 μin)		
	LT	HALAR <sup>(5)</sup>	±1.0 μm (±40 μin)		
		Standard	±14.0 μm (±560 μin)	±18.0 μm (±720 μin)	±24.0 μm (±960 μin)
Repeatability	LN	±0.5 μm (±20 μin)			
	LT	±0.5 μm (±20 μin)			
Straightness and Flatness	Differential	HALSF	1 μm/25 mm (40 μin/in)		
		Standard	2 μm/25 mm (80 μin/in)		
	Maximum Deviation	HALSF	±2.2 μm (±90 μin)	±2.5 μm (±100 μin)	±3.0 μm (±120 μin)
		Standard	±7.0 μm (±275 μin)	±9.0 μm (±360 μin)	±9.0 μm (±360 μin)
Pitch and Yaw		14 arc sec	17 arc sec	20 arc sec	
Nominal Stage Weight		23.0 kg (50.7 lb)	27.0 kg (59.5 lb)	32.5 kg (71.7 lb)	
Moving Mass		6.1 kg (13.4 lb)			
Construction		Aluminum Body/Black Anodize Finish/Hardcoat (62 Rockwell Hardness Teflon <sup>®</sup> Impregnated)			

**Notes:**

- 80 VDC bus limit with standard ribbon cable. Up to 320 VDC is available with round cables.
- Current values based on high performance (-P) magnet track.
- Maximum speed based on stage capability. Maximum application velocity may be limited by system data rate and system resolution.
- Maximum load based on bearing capability. Maximum application load may be limited by acceleration requirements.
- Available with Aerotech controllers.
- Specifications are for single-axis systems, measured 50 mm above the tabletop. Performance of multi-axis systems is payload and workpoint dependent. Consult factory for multi-axis or non-standard applications.

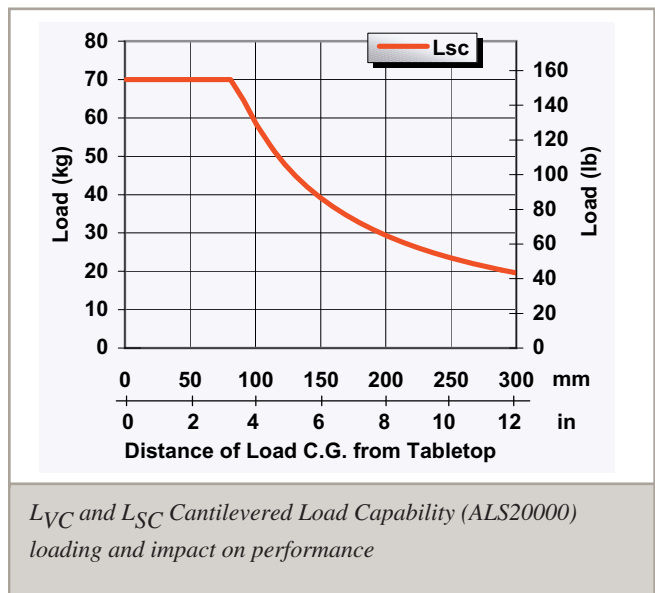
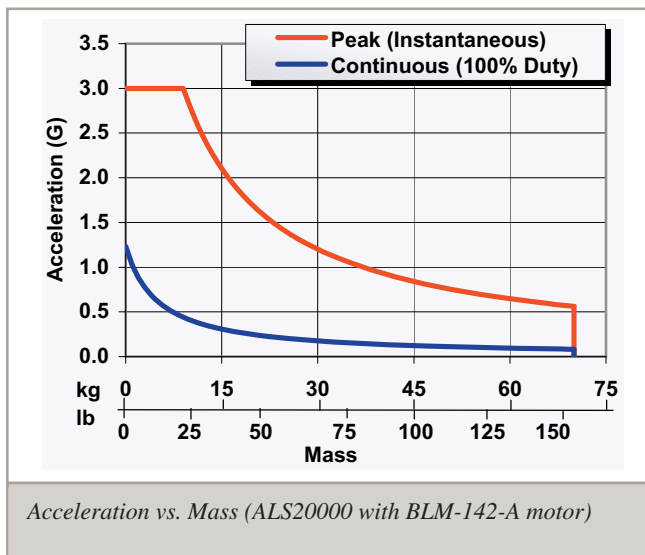

# ALS20000 Series DIMENSIONS

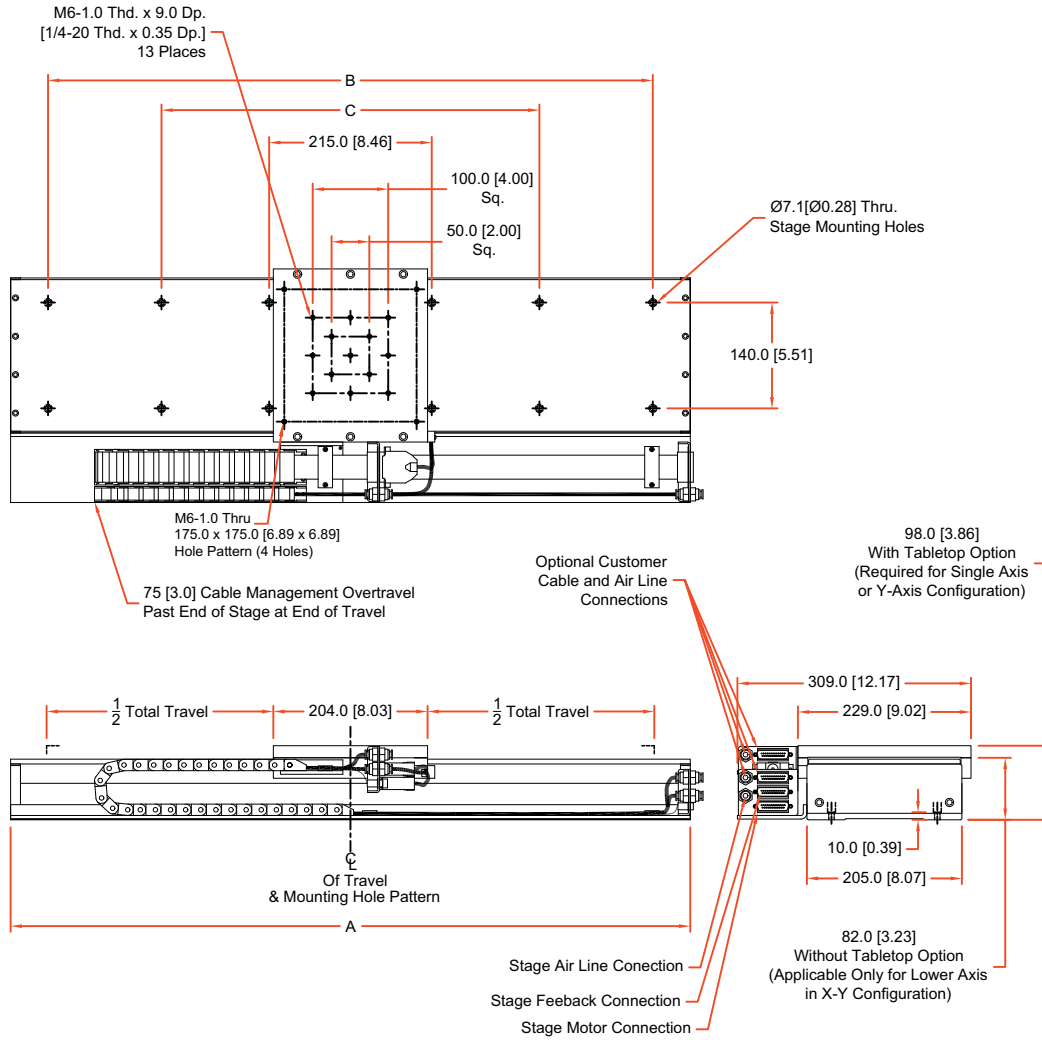

Basic Model	Total Travel	Dimensions - Millimeters [Inches]		
		A	B	C
ALS20010	100.0 [4.00]	391.2 [15.40]	-	-
ALS20020	200.0 [8.00]	492.8 [19.40]	-	-
ALS20030	300.0 [12.00]	594.4 [23.40]	-	500.0 [19.68]
ALS20035	350.0 [13.75]	645.2 [25.40]	-	500.0 [19.68]
ALS20045	450.0 [18.00]	746.8 [29.40]	-	500.0 [19.68]
ALS20060	600.0 [24.00]	899.2 [35.40]	800.0 [31.50]	500.0 [19.68]

## ALS20000 Series ORDERING INFORMATION

### Ordering Example

ALS20	030	-M	-10-S	-LN30AS	-NC	-X CMS
Series	Travel (mm)	Mounting and Grid Pattern	Motor and Magnet Track	Linear Encoder	Limits	Options
	010	-O	-10-S	-LTnnAS	-NC	-X CMS
	020	-M	-10-P	-LTnnX5	-NO	-XY CMS
	030	-U		-LNnnAS		-XYZ CMS
	035					-XYZT CMS
	045					-Y CMS
	060					-YZ CMS
						-YZT CMS

### ALS20000 Series Linear Motor Stage

ALS20010	100 mm (4 in) travel stage with linear motor and limits
ALS20020	200 mm (8 in) travel stage with linear motor and limits
ALS20030	300 mm (12 in) travel stage with linear motor and limits
ALS20035	350 mm (14 in) travel stage with linear motor and limits
ALS20045	450 mm (18 in) travel stage with linear motor and limits
ALS20060	600 mm (24 in) travel stage with linear motor and limits

### Mounting and Grid Pattern

-O	No tabletop
-M	Metric dimension mounting pattern and holes
-U	English dimension mounting pattern and holes

### Motor and Magnet Track

-10-S	Brushless linear motor with standard magnet track (BLM-142-A)
-10-P	Brushless linear motor with high performance magnet track (BLM-142-A)

### Standard Linear Encoders

-LT10AS	Linear encoder for ALS20010; amplified sine output 1 Vpp (20 µm signal period); requires signal multiplier
-LT20AS	Linear encoder for ALS20020; amplified sine output 1 Vpp (20 µm signal period); requires signal multiplier
-LT30AS	Linear encoder for ALS20030; amplified sine output 1 Vpp (20 µm signal period); requires signal multiplier
-LT35AS	Linear encoder for ALS20035; amplified sine output 1 Vpp (20 µm signal period); requires signal multiplier
-LT45AS	Linear encoder for ALS20045; amplified sine output 1 Vpp (20 µm signal period); requires signal multiplier
-LT60AS	Linear encoder for ALS20060; amplified sine output 1 Vpp (20 µm signal period); requires signal multiplier
-LT10X5	Linear encoder for ALS20010; 1.0 micron line driver output
-LT20X5	Linear encoder for ALS20020; 1.0 micron line driver output
-LT30X5	Linear encoder for ALS20030; 1.0 micron line driver output
-LT35X5	Linear encoder for ALS20035; 1.0 micron line driver output
-LT45X5	Linear encoder for ALS20045; 1.0 micron line driver output
-LT60X5	Linear encoder for ALS20060; 1.0 micron line driver output

## ALS20000 Series ORDERING INFORMATION

### High-Accuracy Linear Encoders

-LN10AS	High-accuracy linear encoder for ALS20010; amplified sine output 1 Vpp (4 µm signal period); requires signal multiplier
-LN20AS	High-accuracy linear encoder for ALS20020; amplified sine output 1 Vpp (4 µm signal period); requires signal multiplier
-LN30AS	High-accuracy linear encoder for ALS20030; amplified sine output 1 Vpp (4 µm signal period); requires signal multiplier
-LN35AS	High-accuracy linear encoder for ALS20035; amplified sine output 1 Vpp (4 µm signal period); requires signal multiplier
-LN45AS	High-accuracy linear encoder for ALS20045; amplified sine output 1 Vpp (4 µm signal period); requires signal multiplier
-LN60AS	High-accuracy linear encoder for ALS20060; amplified sine output 1 Vpp (4 µm signal period); requires signal multiplier

Note: Integral signal multipliers available with A3200 amplifier products.

### Limits

-NC	Normally-closed end of travel limit switches (standard)
-NO	Normally-open end of travel limit switches

### Options

-X CMS	Cable management system for single-axis assembly
-XY CMS	Cable management for X-Y assembly; order with X axis only
-XYZ CMS	Cable management for X-Y-Z assembly; order with X axis only
-XYZT CMS	Cable management for X-Y-Z-T assembly; order with X axis only
-Y CMS	Cable management for X-Y assembly; order with Y axis only
-YZ CMS	Cable management for Y-Z assembly; order with Y axis only
-YZT CMS	Cable management for Y-Z-T assembly; order with Y axis only

### Accessories (to be ordered as separate line item)

ALIGNMENT-NPA	Non-precision XY assembly
ALIGNMENT-PA10	XY assembly; 10 arc sec orthogonal
ALIGNMENT-PA5	XY assembly; 5 arc sec orthogonal
HALAR	High-accuracy system – linear error correction for accuracy and repeatability
HALSF	High-accuracy system – improved straightness and flatness