

PRO165 Series

Mechanical Bearing, Ball-Screw Stage

Nine models with travels from 50 mm to 600 mm

Speeds up to 300 mm/s

Side seal design with hard-cover

Low-cost; high performance

NEMA 23 motor flange mount

Long-life linear motion guide bearing system

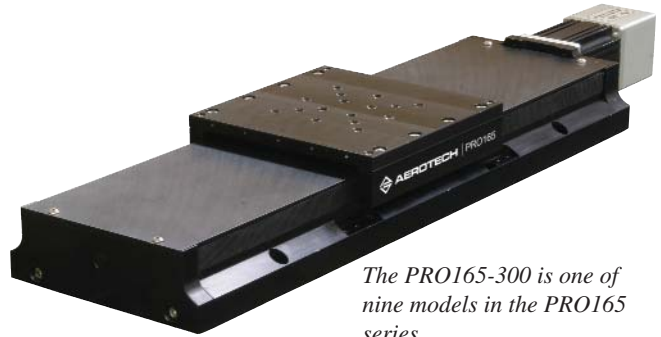

The PRO165-300 is one of nine models in the PRO165 series.

The PRO165 is a medium performance, entry-level linear stage from Aerotech. It is similar in design to the PRO115 series, providing additional load carrying capability with larger bearings and a wider cross-section.

Rugged Construction

The hard-cover design provides protection from debris. The robust aluminum cover is hard-coated providing a scratch-resistant surface.

The side seals keep dirt and particulates out of the stage and protect the bearing surfaces from contamination. The vertical orientation of the seals easily deflects debris away from the stage. The tabletop can be outfitted with an optional brush assembly to remove any particles that collect on the hard cover. Competitive top-seal designs can ingest debris in the seal, resulting in the eventual failure and replacement of the sealing mechanism.

NEMA 23 Motor Support

The PRO165 has a NEMA 23 motor flange mounting interface and can be ordered with an Aerotech standard brushless, slotless rotary motor installed. Alternatively, the stage can be ordered without a motor for the attachment of third party DC brush, brushless, or stepper motors.

Highly Configurable

The stage is equipped with a ground 5 mm/rev ball screw and can be outfitted with English and metric bolt-hole pattern tabletops. A stage mounted brake option is available to prevent back driving the screw when power is removed from the servomotor with the stage in a vertical orientation. A fold-back kit is also available to effectively reduce the overall stage length for space-constrained applications.

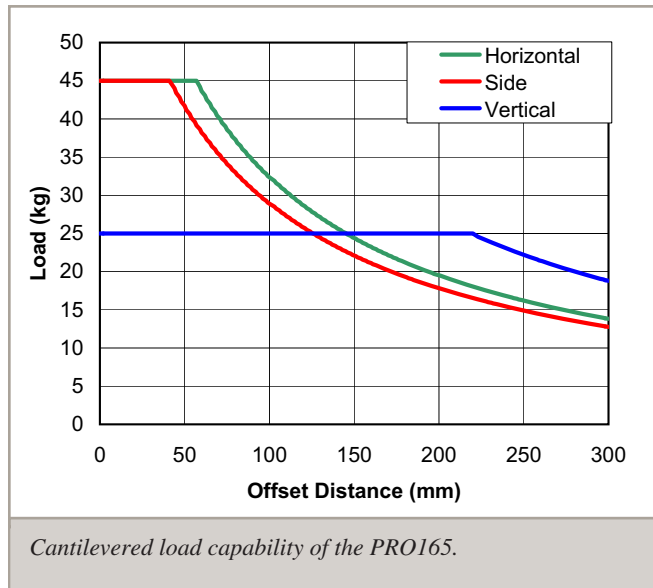

Cantilevered load capability of the PRO165.

PRO165 Series SPECIFICATIONS

Basic Model		PRO165-50	PRO165-100	PRO165-150	PRO165-200	PRO165-250
Total Travel		50 mm	100 mm	150 mm	200 mm	250 mm
Drive System		Precision Ball Screw/Brushless Servomotor				
Bus Voltage		Up to 320 VDC				
Continuous Current	A _{pk}	Up to 2.1 A				
	A _{rms}	Up to 1.5 A				
Feedback		Noncontact Rotary Encoder				
Resolution	5 mm/rev lead	0.5 µm with 2500-line Quadrature Encoder/0.1 µm with 1000-line AS Encoder				
Maximum Travel Speed ⁽¹⁾	5 mm/rev lead	300 mm/s (12 in/s)				
Maximum Acceleration		0.5 g				
Maximum Load ⁽²⁾	Horizontal	45 kg				
	Vertical	25 kg				
	Side	45 kg				
Accuracy	5 mm/rev lead	±6 µm	±6 µm	±8 µm	±8 µm	±8 µm
Bidirectional Repeatability	5 mm/rev lead	±1 µm				
Straightness and Flatness		3 µm	5 µm	6 µm	10 µm	10 µm
Nominal Stage Weight	Less Motor	5.7 kg (12.5 lb)	6.1 kg (13.4 lb)	6.7 kg (14.7 lb)	7.2 kg (15.8 lb)	7.7 kg (16.9 lb)
	With Motor	7.2 kg (15.8 lb)	7.6 kg (16.7 lb)	8.2 kg (18.0 lb)	8.7 kg (19.1 lb)	9.2 kg (20.2 lb)
Construction		Black Anodized Aluminum Body with Hardcoated Tabletop				

Notes:

- Excessive duty cycle may impact stage accuracy.
- Payload specifications are for single-axis system and based on ball screw and bearing life of 2500 km (100 million inches) of travel.
- Specifications are for single-axis systems, measured 50 mm above the tabletop. Performance of multi-axis systems is payload and workpoint dependent. Consult factory for multi-axis or non-standard applications.

Basic Model		PRO165-300	PRO165-400	PRO165-500	PRO165-600
Total Travel		300 mm	400 mm	500 mm	600 mm
Drive System		Precision Ball Screw/Brushless Servomotor			
Bus Voltage		Up to 320 VDC			
Continuous Current	A _{pk}	Up to 2.1 A			
	A _{rms}	Up to 1.5 A			
Feedback		Noncontact Rotary Encoder			
Resolution	5 mm/rev lead	0.5 µm with 2500-line Quadrature Encoder/0.1 µm with 1000-line AS Encoder			
Maximum Travel Speed ⁽¹⁾	5 mm/rev lead	300 mm/s (12 in/s)		250 mm/s (10 in/s)	
Maximum Acceleration		0.5 g			
Maximum Load ⁽²⁾	Horizontal	45 kg			
	Vertical	25 kg			
	Side	45 kg			
Accuracy	5 mm/rev lead	±10 µm	±12 µm	±14 µm	±16 µm
Bidirectional Repeatability	5 mm/rev lead	±1 µm			
Straightness and Flatness		12 µm	16 µm	18 µm	20 µm
Nominal Stage Weight	Less Motor	8.3 kg (18.3 lb)	9.4 kg (20.7 lb)	10.5 kg (23.1 lb)	11.5 kg (25.3 lb)
	With Motor	9.8 kg (21.6 lb)	10.9 kg (24.0 lb)	12.0 kg (26.4 lb)	13.0 kg (28.6 lb)
Construction		Black Anodized Aluminum with Hardcoated Tabletop			

Notes:

- Excessive duty cycle may impact stage accuracy.
- Payload specifications are for single-axis system and based on ball screw and bearing life of 2500 km (100 million inches) of travel.
- Specifications are for single-axis systems, measured 50 mm above the tabletop. Performance of multi-axis systems is payload and workpoint dependent. Consult factory for multi-axis or non-standard applications.

PRO165 Series DIMENSIONS

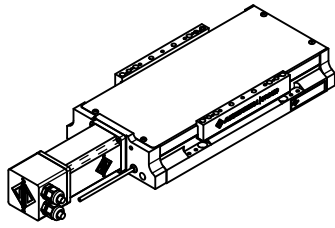

OPTIONAL TABLETOP -TTM [-TTU]

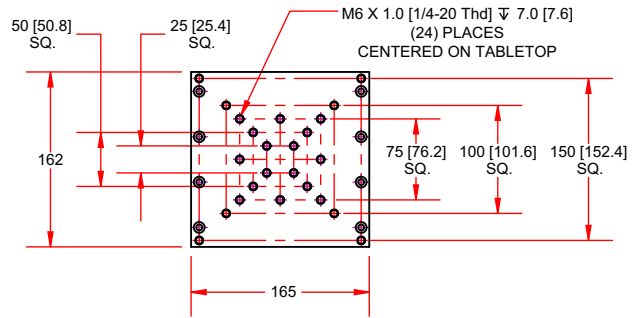

OPTIONAL FOLDBACK -8 ORIENTATION

FOLDBACK LENGTH
-FB025, -FB0375 = 30
-FB025-BRK, -FB0375-BRK = 76.7

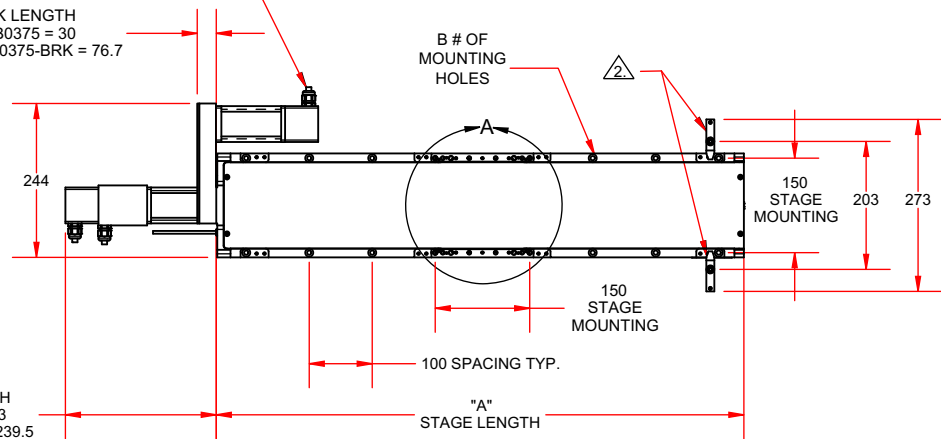

MOTOR LENGTH
BMS100 = 162.3
BMS100-BRAKE = 239.5

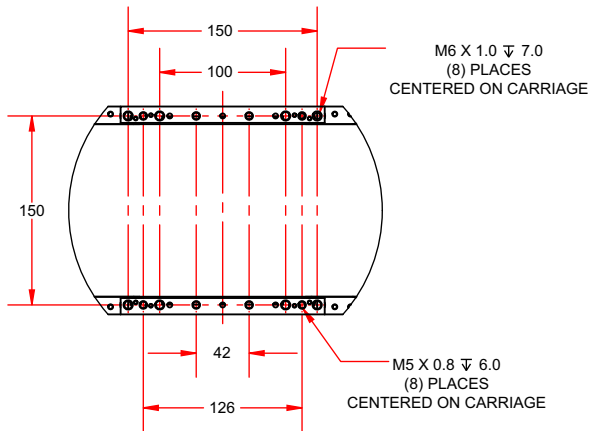
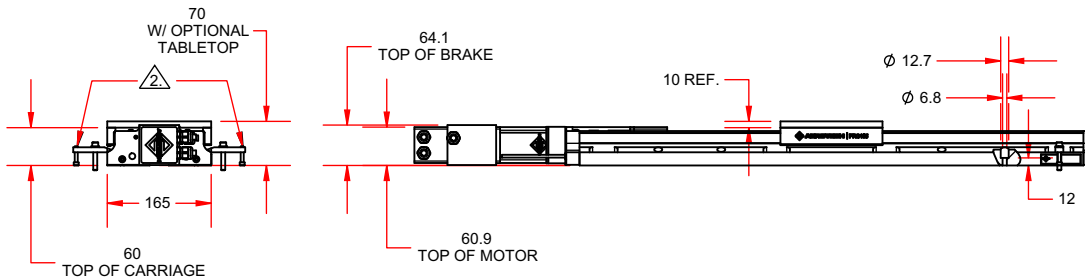

DETAIL A
CARRIAGE MOUNTING HOLES

DIMENSIONS: MILLIMETERS

	A (MM)	B
BASIC MODEL		
PRO165-05MM-050	287.6	4
PRO165-05MM-100	337.6	4
PRO165-05MM-150	387.6	4
PRO165-05MM-200	437.6	8
PRO165-05MM-250	487.6	8
PRO165-05MM-300	537.6	8
PRO165-05MM-400	637.6	12
PRO165-05MM-500	737.6	12
PRO165-05MM-600	837.6	16

NOTES:

△ -TTM TABLETOP OPTION REQUIRED FOR LOWER AXIS OF XY ASSEMBLIES WHEN FOLDBACK OPTION IS CHOSEN.

△ TOE CLAMPS TO BE USED FOR ENGLISH STAGE MOUNTING ONLY.

HDZ165 Bracket

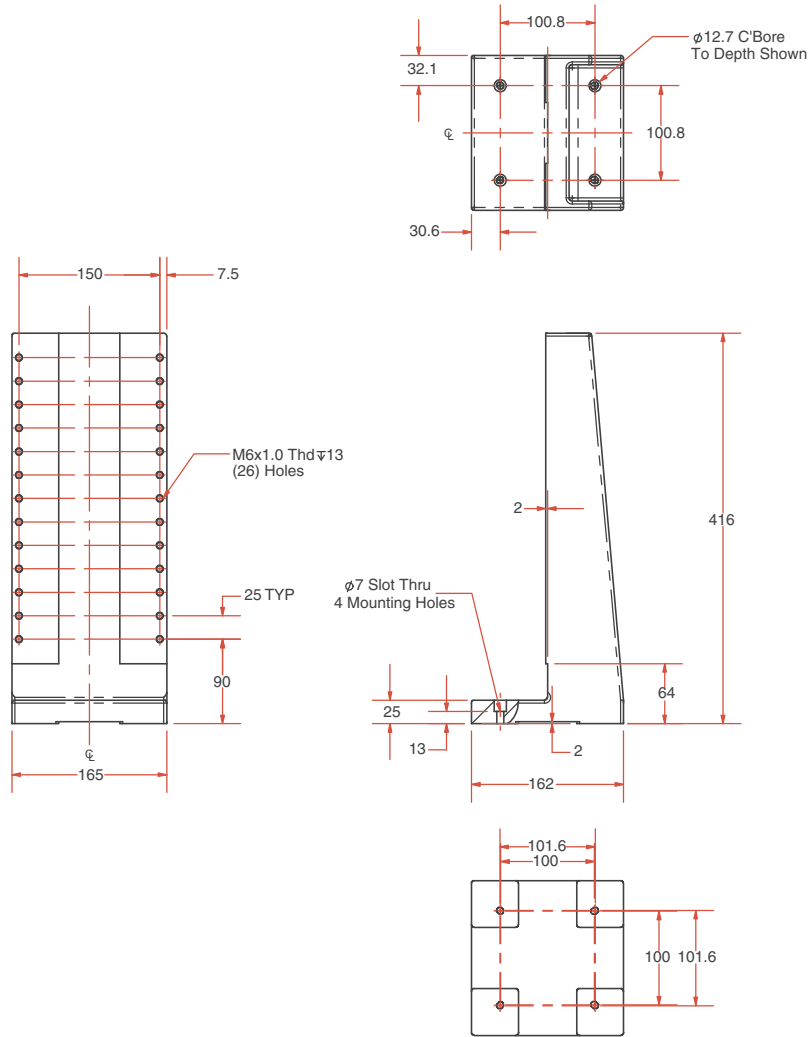

NOTES:

1. DIMENSIONS: MILLIMETERS
2. RECOMMENDED FOR PRO165-050 THRU PRO165-150

PRO165 Series – Tabletop DIMENSIONS

-TT100
MOUNTS ADRS-100
AND CCS130DR-160
NOTE: ALL FEATURES ARE IN ADDITION
TO -TTM TABLETOP FEATURES

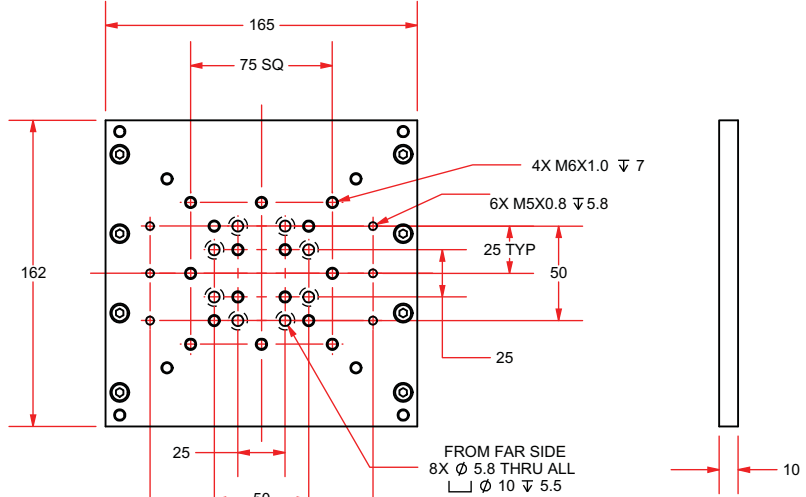

-TT150
MOUNTS ADRS-150 & ADRT-150
NOTE: ALL FEATURES ARE IN ADDITION
TO -TTM TABLETOP FEATURES

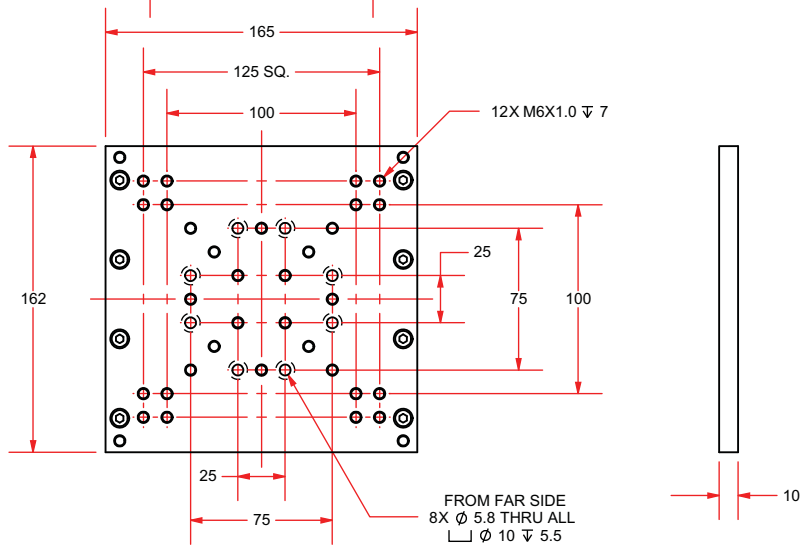

-TTAGR
MOUNTS AGR-75 & AGR-100
NOTE: ALL FEATURES ARE IN ADDITION
TO -TTM TABLETOP FEATURES

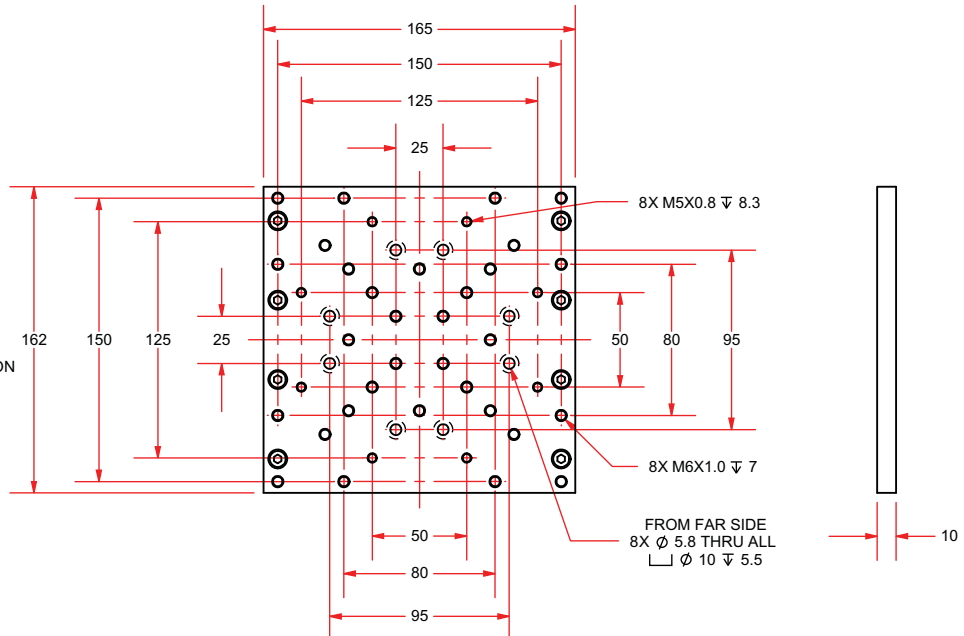

DIMENSIONS: MILLIMETERS

PRO165 Series ORDERING INFORMATION

Ordering Information

PRO165	-05MM	-050	-TTM	-5V-NC	-BMS	-0	-FB025	-NONE	-PLOTS
Series	Ball Screw	Travel (mm)	Tabletop	Limits	Motor	Cable Exit	Options	Coupling	Testing
PRO165	-05MM	-050	-TTM	-5V-NC	-BMS	-0	-FB025	-NONE	-PLOTS
		-100	-TTU	-5V-NO	-BMS-BRK	-2	-FB0375	-C025	-NO PLOTS
		-150	-NO TT	-24V-NC	-NM	-3	-BASE WIPER	-C0375	
		-200	-TT100		-BMS-AS	-4	-LIFTING		
		-250	-TT150		-BMS-AS-BRK	-5	-FB025-BRK		
		-300	-TTAGR			-8	-FB0375-BRK		
		-400	/WIPER						
		-500				-12			
		-600							

Ball Screw

-05MM 5 mm per revolution ball screw

PRO165 Series Linear Ball-Screw Stage

-050	50 mm travel stage with ball screw and limits
-100	100 mm travel stage with ball screw and limits
-150	150 mm travel stage with ball screw and limits
-200	200 mm travel stage with ball screw and limits
-250	250 mm travel stage with ball screw and limits
-300	300 mm travel stage with ball screw and limits
-400	400 mm travel stage with ball screw and limits
-500	500 mm travel stage with ball screw and limits
-600	600 mm travel stage with ball screw and limits

Tabletop

-TTM	Metric pattern tabletop
-TTU	English pattern tabletop
-NO TT	No tabletop
-TT100	Bolt-hole pattern to attach ADRS100 or ACS-100LP rotary stage with vertical or horizontal axis of rotation
-TT150	Bolt-hole pattern to attach ADRS/ADRT150 or ACS-150LP rotary stage with vertical or horizontal axis of rotation
-TTAGR	Bolt-hole pattern to attach AGR-75 or AGR-100 rotary stages
/WIPER	Wiper option for English and metric tabletops

Limits

-5V-NC	5 V normally-closed limits
-5V-NO	5 V normally-open limits
-24V-NC	24 V normally-closed limits

Motor

-BMS	Brushless servomotor with 2500-line feedback encoder (BMS100-A-D25-E2500H)
-BMS-BRK	Brushless servomotor with 2500-line feedback encoder and motor-mounted brake (BMS100-A-D25-E2500H-BK1)
-NM	No motor
-BMS-AS	Brushless slotless servomotor with 1000-line amplified sine encoder (BMS100-A-D25-E1000ASH)
-BMS-AS-BRK	Brushless slotless servomotor with 1000-line amplified sine encoder and brake (BMS100-A-D25-E1000ASH-BK1)

Motor Orientation

-0	No motor
-2	Bottom cable exit
-3	Left side cable exit
-4	Top cable exit
-5	Right side cable exit
-8	Right side fold-back
-12	Left side fold-back

PRO165 Series ORDERING INFORMATION

Options

-FB025	Motor fold-back kit for 0.25-inch diameter motor shaft
-FB0375	Motor fold-back kit for 0.375-inch diameter motor shaft (required for BMS100 motor)
-BASE WIPER	Wiper on base of top axis of XY pair to clear hardcover of bottom axis
-LIFTING	Threaded inserts and lifting lugs; recommended for longer travel stages and XY assemblies; only available for PRO165 stages of 400 mm travel or greater
-FB025-BRK	Motor fold-back kit for 0.25-inch diameter motor shaft; NEMA 23 motor with brake
-FB0375-BRK	Motor fold-back kit for 0.375-inch diameter motor shaft; NEMA 23 motor with brake

Coupling Option

-NONE	No motor coupling supplied
-C025	0.25-inch diameter motor shaft coupling
-C0375	0.375-inch diameter motor shaft coupling

Testing

-PLOTS	Accuracy, repeatability, straightness and flatness plots
-NO PLOTS	No performance plots

Accessories (to be ordered as separate line item)

ALIGNMENT-NPA	Non-precision XY assembly
ALIGNMENT-NPAZ	Non-precision XZ or YZ assembly
ALIGNMENT-PA10	XY assembly; 10 arc sec orthogonal
ALIGNMENT-PA10Z	XZ or YZ assembly with L-bracket; 10 arc second orthogonal
ALIGNMENT-PA5	XY assembly; 5 arc sec orthogonal
ALIGNMENT-PA5Z	XZ or YZ assembly with L-bracket; 5 arc second orthogonal
HDZ165	Right angle L-bracket for PRO165-050, PRO165-100, and PRO165-150 only
TC-PRO165	Toe clamps for mounting PRO stage to an English dimension breadboard or hole pattern; recommended number of toe clamps for each travel length: 50-250 mm travel = 4 clamps; 300-600 mm travel = 8 clamps