



PRO280LM Hardware Manual

Revision: 1.04.00



Global Technical Support

Go to www.aerotech.com/global-technical-support for information and support about your Aerotech, Inc. products. The website supplies software, product manuals, Help files, training schedules, and PC-to-PC remote technical support. If necessary, you can complete Product Return (RMA) forms and get information about repairs and spare or replacement parts. To get help immediately, contact a service office or your sales representative. Include your customer order number in your email or have it available before you call.

United States (World Headquarters)	
Email: Support@aerotech.com Phone: +1-412-967-6440 Fax: +1-412-967-6870	101 Zeta Drive Pittsburgh, PA 15238-2811 www.aerotech.com
United Kingdom	China
Email: Support@aerotech.com Phone: +44 (0)1256 855055 Fax: +44 (0)1256 855649	Email: Support@aerotech.com Phone: +86 (21) 5508 6731
Germany	Taiwan
Email: Support@aerotech.com Phone: +49 (0)911 967 9370 Fax: +49 (0)911 967 93720	Email: Support@aerotech.com Phone: +886 (0)2 8751 6690
France	
Email: Support@aerotech.com Phone: +33 2 37 21 87 65	

This manual contains proprietary information and may not be reproduced, disclosed, or used in whole or in part without the express written permission of Aerotech, Inc. Product names mentioned herein are used for identification purposes only and may be trademarks of their respective companies.

Copyright © 2010-2019, Aerotech, Inc., All rights reserved.

Aerotech Worldwide

United States ■ France ■ Germany ■ United Kingdom
China ■ Taiwan



Table of Contents

- PRO280LM Hardware Manual** **1**
 - Table of Contents 3
 - List of Figures 4
 - List of Tables 5
 - Safety Procedures and Warnings 7
 - EU Declaration of Incorporation 9

- Chapter 1: Overview** **11**
 - 1.1. Environmental Specifications 13
 - 1.2. Accuracy and Temperature Effects 13
 - 1.3. Basic Specifications 14
 - 1.4. Vacuum Operation 16

- Chapter 2: Mechanical Specifications and Installation** **17**
 - 2.1. Unpacking and Handling the Stage 17
 - 2.2. Dimensions 20
 - 2.3. Securing the Stage to the Mounting Surface 23
 - 2.4. Attaching the Payload to the Stage 24
 - 2.4.1. Speed Capability 25

- Chapter 3: Electrical Specifications and Installation** **27**
 - 3.1. Motor and Feedback Connectors 28
 - 3.2. Motor and Feedback Wiring 34
 - 3.3. Motor and Feedback Specifications 36
 - 3.4. Limits, Marker, and Machine Direction 38
 - 3.5. Motor and Feedback Phasing 39

- Chapter 4: Maintenance** **41**
 - 4.1. Service and Inspection Schedule 41
 - 4.2. Cleaning and Lubrication 42
 - 4.3. Troubleshooting 46

- Appendix A: Warranty and Field Service** **47**

- Appendix B: Technical Changes** **49**

- Index** **51**

List of Figures

Figure 2-1: Shipping Brackets Used on Single Axis Stages or Upper Axes of XY Systems18

Figure 2-2: PRO280LM Series Stage with Lifting Features 19

Figure 2-3: PRO280LM Dimensions 20

Figure 2-4: PRO280LM Accessory Tabletop Dimensions (-TT3, -TT6 Options)21

Figure 2-5: Dimensions for Stages without a Cable Management System (-CMS0 Option)22

Figure 2-6: Cantilevered Load Capability of PRO280LM Series Stages 25

Figure 2-7: Stage Orientations25

Figure 3-1: Ground Connection Points for the -CMS0 Option 28

Figure 3-2: Motor and Feedback Wiring 34

Figure 3-3: Motor and Feedback Wiring for a Typical Vertical or Rotary Axis Stage 35

Figure 3-4: Machine Direction 38

Figure 3-5: Hall Phasing 39

Figure 3-6: Analog Encoder Phasing Reference Diagram (-E1 Incremental Encoder) 40

Figure 3-7: Encoder Phasing Reference Diagram (-E2 Incremental Encoder) 40

Figure 4-1: Endplate Cover Removal (Step 2) 44

Figure 4-2: Hardcover Screw Removal (Step 3) 44

Figure 4-3: Hardcover Removal (Step 3) 45

List of Tables

Table 1-1: Model Numbers and Ordering Options 11

Table 1-2: Environmental Specifications 13

Table 1-3: PRO280LM Series Specifications (-0300 to -0600) 14

Table 1-4: PRO280LM Series Specifications (-0800 to -1500) 15

Table 2-1: Stage Mounting Surface Flatness Requirement 23

Table 2-2: Stage to Mounting Surface Hardware 23

Table 3-1: Motor Connector Pinout 29

Table 3-2: Mating Connector Part Numbers for the Motor Connector 29

Table 3-3: Feedback Connector Pinout (-E1 and -E2 Options) 30

Table 3-4: Mating Connector Part Numbers for the Feedback Connector 30

Table 3-5: Feedback Connector Pinout (-E3 Option) 31

Table 3-6: Mating Connector Part Numbers for the Feedback Connector 31

Table 3-7: General Motor Connector Pinout (for Z or T Axes) 32

Table 3-8: Mating Connector Part Numbers for the Motor Connector 32

Table 3-9: General Feedback Connector Pinout (for Z or T axes) 33

Table 3-10: Mating Connector Part Numbers for the Feedback Connector 33

Table 3-11: Feedback Specifications 36

Table 3-12: PRO280LM Linear Motor Specifications (BLMH-262-A) 37

Table 3-13: Encoder Specifications 37

This page intentionally left blank.

Safety Procedures and Warnings

This manual tells you how to carefully and correctly use and operate the PRO280LM. Read all parts of this manual before you install or operate the PRO280LM or before you do maintenance to your system. To prevent injury to you and damage to the equipment, obey the precautions in this manual. The precautions that follow apply when you see a Danger or Warning symbol in this manual. If you do not obey these precautions, injury to you or damage to the equipment can occur. If you do not understand the information in this manual, contact Aerotech Global Technical Support.

This product has been designed for light industrial manufacturing or laboratory environments. The protection provided by the equipment could be impaired if the product is used in a manner not specified by the manufacturer.

NOTE: Aerotech continually improves its product offerings; listed options may be superseded at any time. All drawings and illustrations are for reference only and were complete and accurate as of this manual's release. Refer to www.aerotech.com for the most up-to-date information.



DANGER: This product contains potentially lethal voltages. To reduce the possibility of electrical shock, bodily injury, or death the following precautions must be followed.

1. Access to the PRO280LM and component parts must be restricted while connected to a power source.
2. Do not connect or disconnect any electrical components or connecting cables while connected to a power source.
3. Disconnect electrical power before servicing equipment.
4. All components must be properly grounded in accordance with local electrical safety requirements.
5. Operator safeguarding requirements must be addressed during final integration of the product.



WARNING: To minimize the possibility of electrical shock, bodily injury or death the following precautions must be followed.

1. Moving parts can cause crushing or shearing injuries. Access to all stage and motor parts must be restricted while connected to a power source.
2. Cables can pose a tripping hazard. Securely mount and position all system cables to avoid potential hazards.
3. Do not expose this product to environments or conditions outside of the listed specifications. Exceeding environmental or operating specifications can cause damage to the equipment.
4. The PRO280LM stage must be mounted securely. Improper mounting can result in injury and damage to the equipment.
5. Use care when moving the PRO280LM stage. Lifting or transporting the PRO280LM stage improperly can result in injury or damage to the PRO280LM.
6. The stage forcer temperature may exceed 75°C.
7. Operators must be trained before operating this equipment.
8. All service and maintenance must be performed by qualified personnel.

This page intentionally left blank.

EU Declaration of Incorporation

Manufacturer: Aerotech, Inc.
101 Zeta Drive
Pittsburgh, PA 15238-2811
USA

herewith declares that the product:
PRO280LM Linear Stage

is intended to be incorporated into machinery to constitute machinery covered by the Directive 2006/42/EC as amended;

and that the following harmonized European standards have been applied:

EN ISO 12100:2010

Safety of machinery - Basic concepts, general principles for design

EN 60204-1:2010

Safety of machinery - Electrical equipment of machines - Part 1: General requirements

and further more declares that

it is not allowed to put the equipment into service until the machinery into which it is to be incorporated or of which it is to be a component has been found and declared to be in conformity with the provisions of the Directive 2006/42/EC and with national implementing legislation, i.e., as a whole, including the equipment referred to in this Declaration.

This is to certify that the aforementioned product is in accordance with the applicable requirements of the following Directive(s):

2011/65/EU

RoHS 2 Directive

Authorized Representative: Simon Smith, European Director
Address: Aerotech Ltd
The Old Brick Kiln, Ramsdell, Tadley
Hampshire RG26 5PR
UK

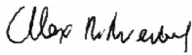
Name  / Alex Weibel
Position Engineer Verifying Compliance
Location Pittsburgh, PA
Date 8/6/2019



This page intentionally left blank.

Chapter 1: Overview

The specifications in this manual pertain to the second generation of PRO LM stages. Second generation stages can be distinguished from their first generation counterparts by the second generation's curved hardcover. Contact Aerotech if you need a first generation manual.

Table 1-1: Model Numbers and Ordering Options

PRO280LM Linear Motor Stage	
-0300	300 mm travel stage
-0400	400 mm travel stage
-0500	500 mm travel stage
-0600	600 mm travel stage
-0800	800 mm travel stage
-1000	1000 mm travel stage
-1200	1200 mm travel stage
-1500	1500 mm travel stage
Mounting Orientation (Required)	
	Normal mounting orientation
-MT1	Side mounted or vertical orientation
-MT2	Inverted mounting orientation
Tabletop (Required)	
-TT1	Tabletop with metric dimension mounting
-TT2	Tabletop with English dimension mounting
-TT3	Accessory tabletop with mounting for select rotary stages
-TT4	Tabletop with metric dimension mounting and wiper brushes
-TT5	Tabletop with English dimension mounting and wiper brushes
-TT6	Accessory tabletop with mounting for select rotary stages and wipers
NOTE: -TT1 option required for lower axis of XY	
Feedback (Required)	
-E1	Incremental linear encoder; 1 Vpp
-E2	Incremental linear encoder; 0.1 μ m digital TTL output
-E3	Absolute linear encoder; EnDat 2.2

PRO280LM Linear Motor Stage	
Cable Management (Required)	
-CMS0	No external CMS; motor/feedback connector bracket on carriage
-CMS1	External CMS for single axis
-CMS2	External CMS for lower-axis of two-axis PRO (XY) assembly
-CMS3	External CMS for lower-axis of two-axis (XZ or XT) assembly
-CMS4	External CMS for upper-axis of two-axis PRO (XY) assembly
-CMS5	External CMS for upper-axis of two-axis (YZ or YT) assembly
-CMS6	External CMS for lower-axis of three-axis (XYZ or XYT) assembly
-CMS7	External CMS for lower-axis of three-axis (XZT) assembly
-CMS8	External CMS for upper-axis of four-axis (XYZT) assembly
-CMS9	External CMS for lower-axis of four-axis (XYZT) assembly
Lifting Hardware (Optional)	
-LF	Lifting hardware
NOTE: Lifting option available on all travels. Lifting should never be ordered on the upper-axis of an XY set (only order on lower-axis)	
ThermoComp™ (Optional)	
-TCMP	ThermoComp™ integrated thermal compensation, single or lower axis
NOTE: An A3200 controller must be used with the -TCMP option	
Metrology (Required)	
-PL0	No metrology performance plots
-PL1	Uncalibrated with performance plots
-PL2	Calibrated with performance plots
Accessories (To be Ordered as a Separate Line Item)	
ALIGN-NPA	Non-precision XY assembly
ALIGN-NPAZ	Non-precision XZ or YZ assembly
ALIGN-PA10	XY assembly; 10 arc sec orthogonality. Alignment to within 7 μm orthogonality for short travel stages.
ALIGN-PA10Z	XZ or YZ assembly with L-bracket; 10 arc sec orthogonality. Alignment to within 10 μm orthogonality for short travel stages.
ALIGN-PA5	XY assembly; 5 arc sec orthogonality. Alignment to within 3 μm orthogonality for short travel stages
ALIGN-PA5Z	XZ or YZ assembly with L-bracket; 5 arc sec orthogonality. Alignment to within 5 μm orthogonality for short travel stages.

1.1. Environmental Specifications



WARNING: Do not expose this product to environments or conditions outside of the listed specifications. Exceeding environmental or operating specifications can cause damage to the equipment.

Table 1-2: Environmental Specifications

Ambient Temperature	Operating: 10° to 35° C (50° to 95° F) The optimal operating temperature is 20° C \pm 2° C (68° F \pm 4° F). If at any time the operating temperature deviates from 20° C degradation in performance could occur.
	Storage: 0° to 40° C (32° to 104° F) in original shipping packaging
Humidity	Operating: 20% to 60% RH
	Storage: 10% to 70% RH, non-condensing in original packaging. The stage should be packaged with desiccant if it is to be stored for an extended time.
Altitude	Operating: 0 m to 2,000 m (0 ft to 6,562 ft) above sea level Contact Aerotech if your specific application involves use above 2,000 m or below sea level.
Vibration	Use the system in a low vibration environment. Excessive floor or acoustical vibration can affect system performance. Contact Aerotech for information regarding your specific application.
Protection Rating	The PRO280LM stages have limited protection against dust, but not water. This equates to an ingress protection rating of IP50.
Use	Indoor use only

1.2. Accuracy and Temperature Effects

The accuracy specification of PRO280LM series stages is measured 25 mm above the table with the stage in an unloaded condition. The stage is assumed to be fully supported by a mounting surface meeting or exceeding the specification in [Section 2.3](#).

The accuracy specifications listed in [Section 1.3](#) assume a 20°C operating environment. If the temperature of the stage differs from 20°C, the encoder scale in the stage will expand or contract at the rate of 3.25 ppm per °C.

The ThermoComp™ option is a hardware and software solution that uses the functionality of the A3200 controller to mitigate the effects of changing temperature by detecting and compensating for thermal changes. ThermoComp™ is effective at compensating for both self-heating and environmental temperature changes.

1.3. Basic Specifications

NOTE: Aerotech continually improves its product offerings; listed options may be superseded at any time. All drawings and illustrations are for reference only and were complete and accurate as of this manual's release. Refer to www.aerotech.com for the most up-to-date information.

Table 1-3: PRO280LM Series Specifications (-0300 to -0600)

PRO280LM		-0300	-0400	-0500	-0600
Travel		300 mm	400 mm	500 mm	600 mm
Accuracy ⁽¹⁾	Standard	±10 µm	±12 µm	±14 µm	±15.5 µm
	Calibrated	±1 µm	±1 µm	±1 µm	±1 µm
Resolution (Minimum Incremental Motion)		5 nm (-E1 Encoder), 10 nm (-E3 Encoder)			
Bidirectional Repeatability ⁽¹⁾		±0.4 µm	±0.4 µm	±0.4 µm	±0.4 µm
Horizontal Straightness ⁽¹⁾		±3 µm	±4 µm	±5 µm	±6 µm
Vertical Straightness ⁽¹⁾		±3 µm	±4 µm	±5 µm	±6 µm
Pitch		49 µrad (10.1 arc sec)	60 µrad (12.4 arc sec)	70 µrad (14.4 arc sec)	78 µrad (16.1 arc sec)
Roll		49 µrad (10.1 arc sec)	60 µrad (12.4 arc sec)	70 µrad (14.4 arc sec)	78 µrad (16.1 arc sec)
Yaw		49 µrad (10.1 arc sec)	60 µrad (12.4 arc sec)	70 µrad (14.4 arc sec)	78 µrad (16.1 arc sec)
Maximum Speed ⁽²⁾		2 m/s			
Maximum Acceleration ⁽²⁾		3 g			
Maximum Force, Continuous		266.2 N - Standard 437.1 N - With Air Cooling (20 psig)			
Load Capacity ⁽³⁾	Horizontal	150 kg			
	Side	150 kg			
Moving Mass		13.8 kg			
Stage Mass		51.7 kg	56.9 kg	62.2 kg	67.4 kg
Material		Anodized Aluminum			
Mean Time Between Failure		20,000 Hours			
<p>1. Certified with the PL1 option.</p> <p>2. Requires the selection of an appropriate amplifier with sufficient voltage and current.</p> <p>3. Axis orientation for on-axis loading is listed.</p> <p>4. Specifications are for single-axis systems measured 25 mm above the tabletop; performance of multi-axis system is payload and workpoint dependent. Consult the Aerotech factory for multi-axis or non-standard applications.</p>					

Table 1-4: PRO280LM Series Specifications (-0800 to -1500)

PRO280LM		-0800	-1000	-1200	-1500
Travel		800 mm	1000 mm	1200 mm	1500 mm
Accuracy ⁽¹⁾	Standard	±17 µm	±18 µm	±21 µm	±22 µm
	Calibrated	±1.5 µm	±1.5 µm	±2 µm	±2 µm
Resolution (Minimum Incremental Motion)		5 nm (-E1 Encoder), 10 nm (-E3 Encoder)			
Bidirectional Repeatability ⁽¹⁾		±0.5 µm	±0.5 µm	±0.5 µm	±0.5 µm
Horizontal Straightness ⁽¹⁾		±7 µm	±8 µm	±8.5 µm	±9.5 µm
Vertical Straightness ⁽¹⁾		±7 µm	±8 µm	±8.5 µm	±9.5 µm
Pitch		90 µrad (18.6 arc sec)	110 µrad (22.7 arc sec)	120 µrad (24.7 arc sec)	130 µrad (26.8 arc sec)
Roll		90 µrad (18.6 arc sec)	110 µrad (22.7 arc sec)	120 µrad (24.7 arc sec)	130 µrad (26.8 arc sec)
Yaw		90 µrad (18.6 arc sec)	110 µrad (22.7 arc sec)	120 µrad (24.7 arc sec)	130 µrad (26.8 arc sec)
Maximum Speed ⁽²⁾		2 m/s			
Maximum Acceleration ⁽²⁾		3 g			
Maximum Force, Continuous		266.2 N - Standard 437.1 N - With Air Cooling (20 psig)			
Load Capacity ⁽³⁾	Horizontal	150 kg			
	Side	150 kg			
Moving Mass		13.8 kg			
Stage Mass		78.0 kg	88.5 kg	99.0 kg	114.8 kg
Material		Anodized Aluminum			
Mean Time Between Failure		20,000 Hours			
1. Certified with the PL1 option. 2. Requires the selection of an appropriate amplifier with sufficient voltage and current. 3. Axis orientation for on-axis loading is listed. 4. Specifications are for single-axis systems measured 25 mm above the tabletop; performance of multi-axis system is payload and workpoint dependent. Consult the Aerotech factory for multi-axis or non-standard applications.					

1.4. Vacuum Operation

Aerotech can specially prepare the PRO280LM for operation in vacuum environments. Aerotech offers two vacuum preparation options; one for low vacuum (for use in atmospheric pressures to 10^{-3} torr) and one for high vacuum (preparation for environments from 10^{-3} to 10^{-6} torr). As part of this preparation, attention to detail during modification, cleaning, and assembly results in products with optimal performance in vacuum applications.

Special Guidelines

To make sure that the PRO280LM will continue to perform well in the vacuum environment, use the guidelines that follow (in addition to standard handling, installation, and lubrication guidelines outlined in this manual).

1. Do not remove the PRO280LM from its sealed bag until it is ready to use.
2. Always handle the PRO280LM in a clean environment and use powder-free polyethylene gloves to prevent any contaminants from adhering to the surface of the PRO280LM.
3. During installation, use cleaned, vented, stainless steel fasteners when securing the PRO280LM.
4. Reduced air pressure eliminates significant convective heat transfer. This, coupled with the viscous vacuum-compatible lubricants, could result in excessive motor operating temperatures. Because of this, consider all continuous torque ratings to be 40 to 60% lower than the value specified for operation in normal atmospheric environment. Reduce motor usage accordingly.
5. For vacuum applications, the recommended lubricant is a small quantity of **Braycote® 602EF** grease or a compatible substitute of equal quality.
6. Baking vacuum components between 100 and 125 °C for 24 to 48 hours significantly reduces outgassing at initial pump-down to vacuum pressure and evaporates water vapor that impregnates porous surfaces on the aluminum and Teflon cables. Aerotech recommends that customers bake out vacuum systems when first installing them in the vacuum chamber.

Chapter 2: Mechanical Specifications and Installation



WARNING: PRO280LM installation must be in accordance to instructions provided by this manual and any accompanying documentation. Failure to follow these instructions could result in injury or damage to the equipment.

2.1. Unpacking and Handling the Stage



DANGER/HEAVY: Refer to [Section 1.3](#) for stage mass specifications.

- Do not attempt to lift heavy loads single handed.
- Lift only by the base. Use lifting hardware if it has been provided (refer to [Figure 2-2](#)).
- Do not use the tabletop or cables as lifting points.
- For multi-axis assemblies, always lift the system by the lower axis.



WARNING: It is the customer's responsibility to safely and carefully lift and move the PRO280LM.

- Secure all moving parts before lifting or moving the PRO280LM to a new location. Unsecured moving parts could shift and cause bodily injury.
- Improper handling could adversely affect the performance of the PRO280LM. Use care when moving the PRO280LM.

Carefully remove the PRO280LM from its protective shipping container. Gently set the PRO280LM on a smooth, flat, and clean surface.

Before operating the PRO280LM, it is important to let it stabilize at room temperature for at least 12 hours. Allowing it to stabilize to room temperature will ensure that all of the alignments, preloads, and tolerances are the same as they were when tested at Aerotech. Use compressed nitrogen or clean, dry, oil-less air to remove any dust or debris that has collected during shipping.

Each PRO280LM has a label listing the system part number and serial number. These numbers contain information necessary for maintaining or updating system hardware and software. Locate this label and record the information for later reference.

Shipping Brackets

All PRO280LM series stages are packaged with shipping brackets installed to prevent unwanted stage motion and potential damage from occurring during shipment. The brackets are red anodized aluminum (the only red anodized pieces Aerotech uses) that attach to the stage base on either side of the stage carriage. The rubber pads on the shipping brackets compress slightly to gently hold the carriage in place. Two shipping brackets are used on single axis and upper axis stages in a multi-axis stack, while four shipping brackets are used on lower axis stages in multi-axis stacks. They must be removed from the stage for the stage to operate. Retain the brackets for future use.

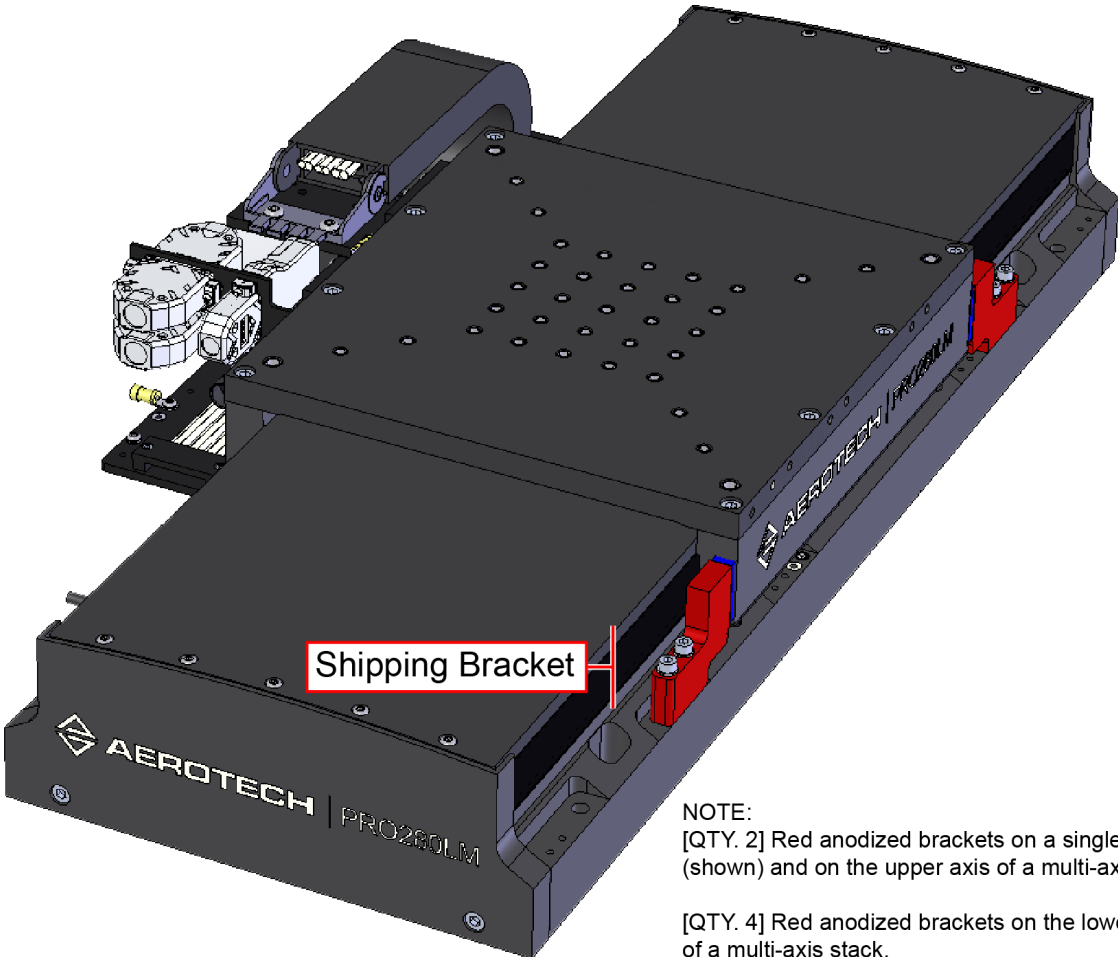

NOTE:
[QTY. 2] Red anodized brackets on a single axis (shown) and on the upper axis of a multi-axis stack.

[QTY. 4] Red anodized brackets on the lower axis of a multi-axis stack.

Figure 2-1: Shipping Brackets Used on Single Axis Stages or Upper Axes of XY Systems

NOTE: After removing the shipping brackets, retain them for future use. Do not transport or ship the PRO280LM without the shipping brackets attached.

Lifting Instructions

This section applies only to stages equipped with lifting features. The lifting features should come attached to the system and contain (QTY 4) eye bolts and (QTY 4) standoffs (see [Figure 2-2](#)). The eyebolts are threaded into the standoffs and the standoffs are threaded into the stage base. These must be removed for the stage to operate. Retain the lifting hardware for future use.

If the stage must be lifted in the future, reattach the shipping brackets and the lifting hardware. If the stage is part of a multi-axis system, attach the lifting features to the lower axis.

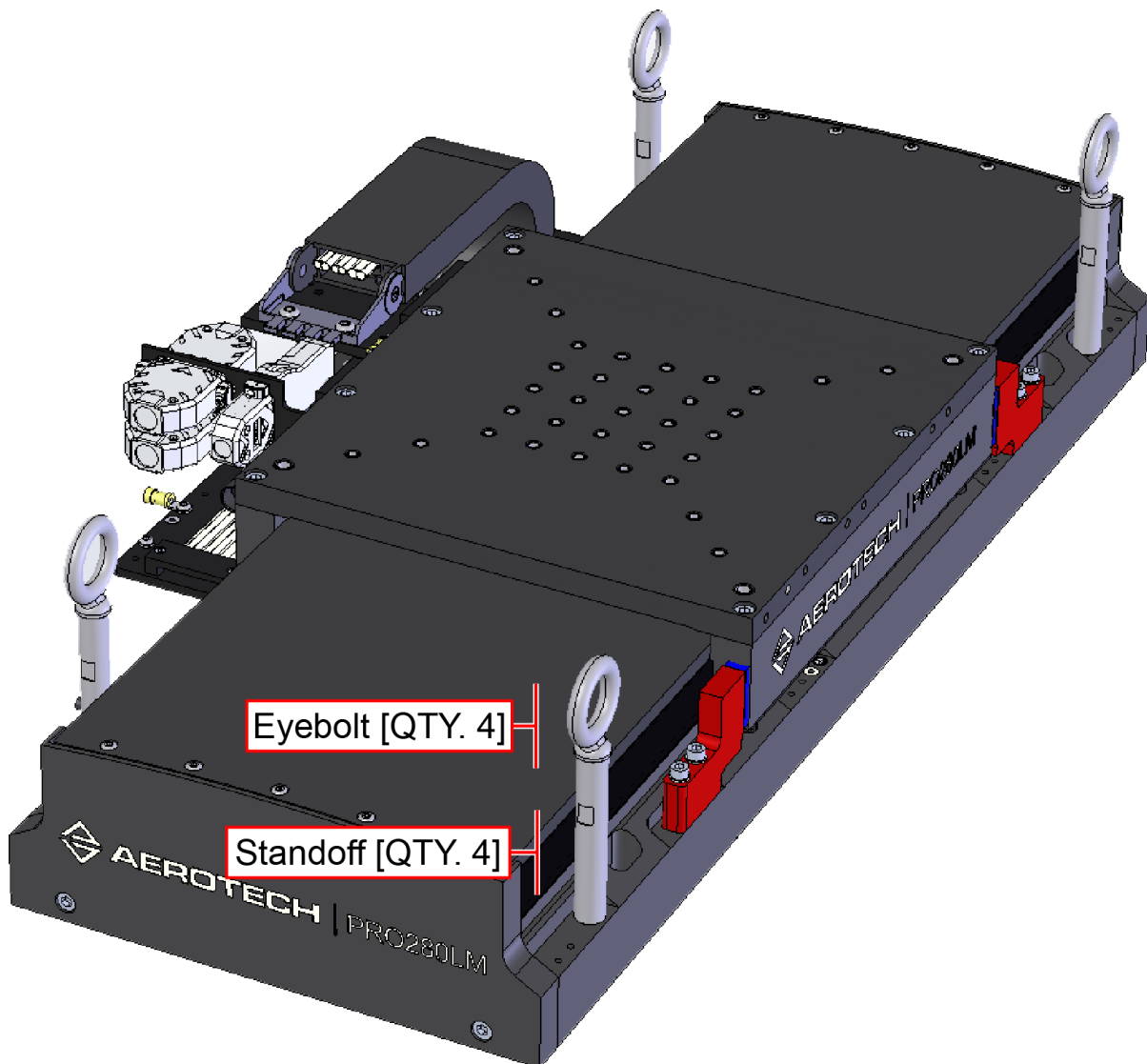
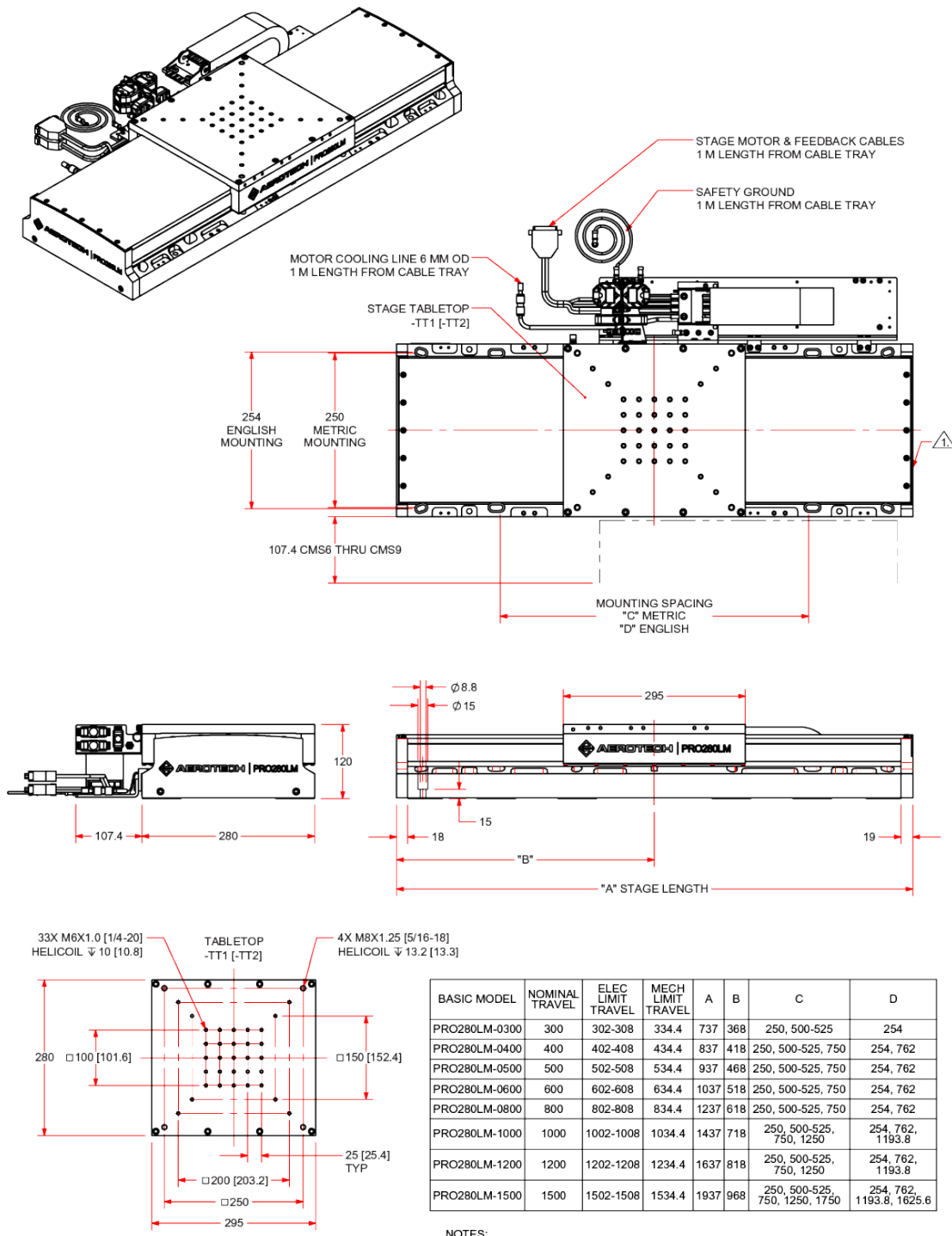

Figure 2-2: PRO280LM Series Stage with Lifting Features

NOTE: After removing the shipping brackets, retain them for future use. Do not transport or ship the PRO280LM without the shipping brackets attached.

2.2. Dimensions



NOTES:

1. M5X0.8 FOR CUSTOMER-INSTALLED AIR PURGE FITTING.

2. DIMENSIONS: MILLIMETERS.

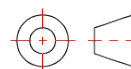

Figure 2-3: PRO280LM Dimensions

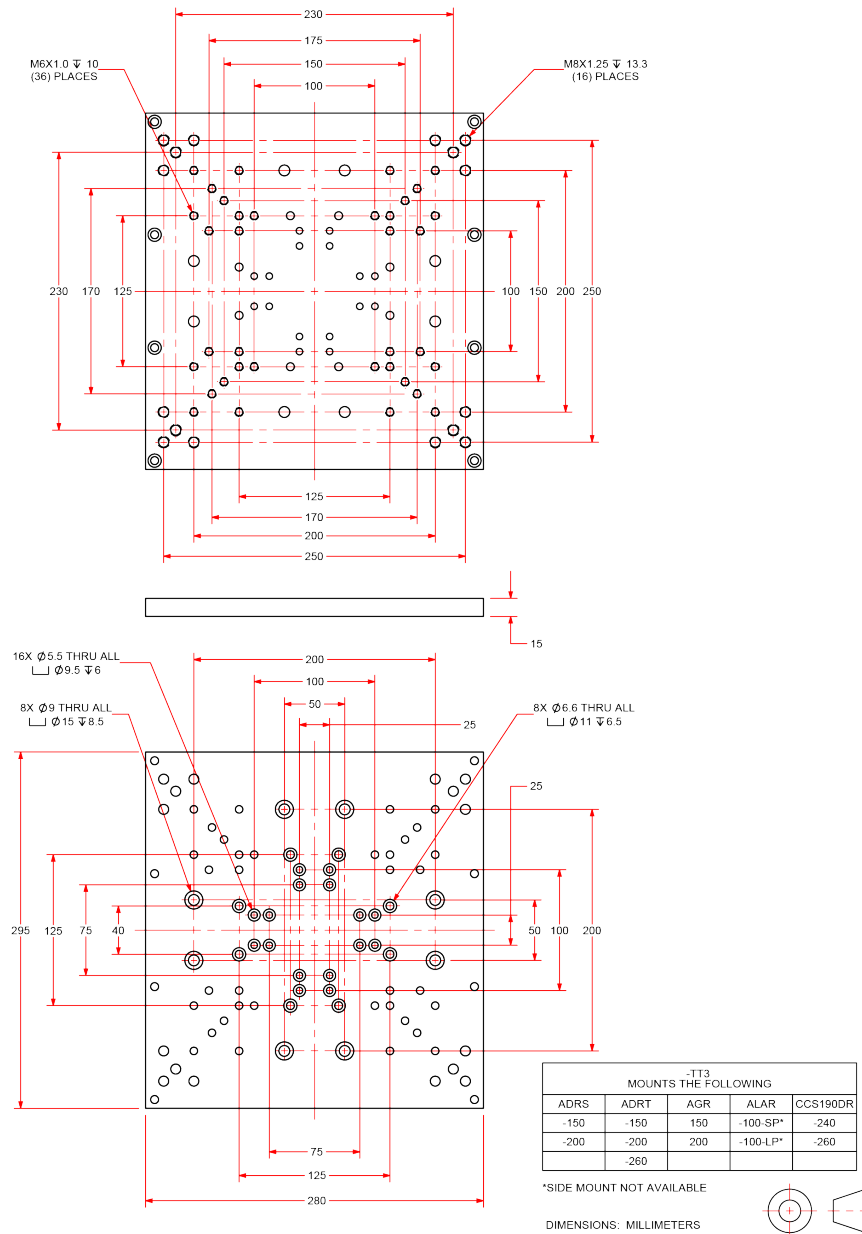

Figure 2-4: PRO280LM Accessory Tabletop Dimensions (-TT3, -TT6 Options)

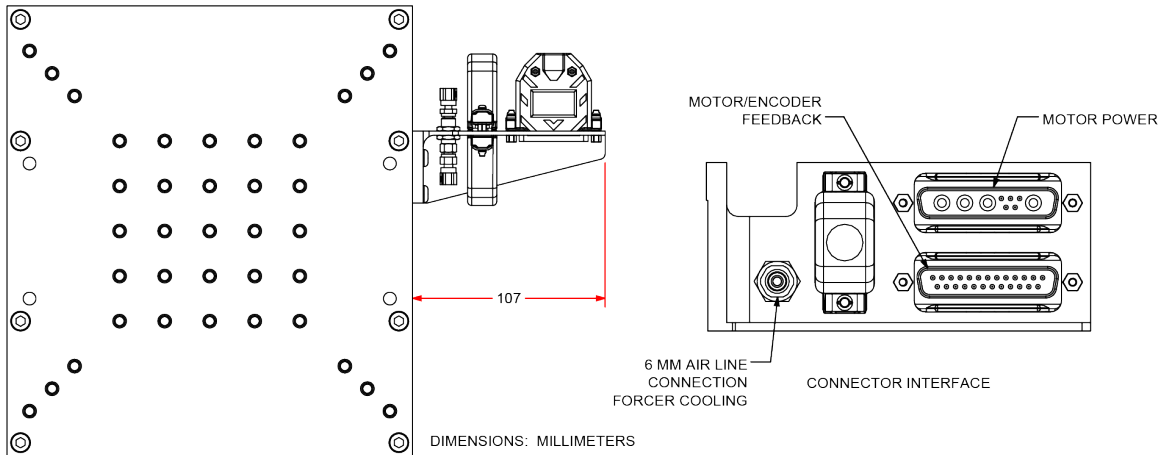

Figure 2-5: Dimensions for Stages without a Cable Management System (-CMS0 Option)

2.3. Securing the Stage to the Mounting Surface



WARNING: The PRO280LM must be mounted securely. Improper mounting can result in injury and damage to the equipment.



WARNING: Make sure that all moving parts are secure before moving the PRO280LM. Unsecured moving parts may shift and cause bodily injury.



WARNING: Do not attempt to manually move the PRO280LM if it is connected to a power source.



DANGER: PINCH POINT! Keep Hands Clear while the stage is in motion.

The mounting surface must be flat and have adequate stiffness to achieve the maximum performance from the PRO280LM stage. When it is mounted to a non-flat surface, the stage can be distorted while the mounting screws are tightened. This distortion will decrease overall accuracy. Adjustments to the mounting surface must be done before the stage is secured.

Inspect the mounting surface for dirt or unwanted residue and clean if necessary. Use precision flatstones on the mounting surface to remove any burrs or high spots. Clean the mounting surface with a lint-free cloth and acetone or isopropyl alcohol and allow the cleaning solvent to completely dry. Gently place the stage on the mounting surface.

NOTE: The PRO280LM is precision machined and verified for flatness prior to product assembly at the factory. If machining is required to achieve the desired flatness, it should be performed on the mounting surface rather than the PRO280LM. Shimming should be avoided if possible. If shimming is required, it should be minimized to retain maximum rigidity of the system.

Table 2-1: Stage Mounting Surface Flatness Requirement

Stage Travel	Flatness Requirement
All Travels	7.5 μm

If necessary, manually move the stage table to access the mounting holes along the edges of the stage. This stage is designed to use socket head cap screws (SHCS) to secure the base to the mounting surface.

NOTE: If the stage is not connected to a power source, the stage should move freely by hand. Do not attempt to manually move the stage if it is connected to a power source.

Tightening torque values for the mounting hardware are dependent on the properties of the surface to which the stage is being mounted. Values provided in [Table 2-2](#) are typical values and may not be accurate for your mounting surface. Refer to [Section 2.2](#) for specific model mounting locations and dimensions.

Table 2-2: Stage to Mounting Surface Hardware

Mounting Hardware	Typical Screw Torque
M8 x 30 mm (or 5/16" x 1-1/8") SHCS with custom flat washers (provided by Aerotech)	16.8 N·m [12 ft·lb]

2.4. Attaching the Payload to the Stage

Inspect the mounting surface for dirt or unwanted residue and clean if necessary. Clean the mounting surface with a lint-free cloth and acetone or isopropyl alcohol and allow the cleaning solvent to completely dry.

Aerotech recommends that customers use a representative payload during start-up to prevent accidental damage to the stage and the payload. Proceed with the electrical installation and test the motion control system in accordance with the system documentation. Document all results for future reference. For information on electrical installation refer to [Chapter 3](#) and the documentation delivered with the stage.

NOTE: If your PRO280LM was purchased with Aerotech controls, it might have been tuned with a representative payload based on the information provided at the time of order. If the PRO280LM is started up without a payload, the servo gains provided by Aerotech with the shipment may not be appropriate and servo instability can occur. Refer to the controller help file for tuning assistance.

The payload must be flat, rigid, and comparable to the stage in quality to maintain optimum performance.

NOTE: For valid system performance, the mounting interface should be flat within 12 μm .



WARNING: Refer to the dimensions in [Section 2.2](#) for maximum allowable thread engagement. A screw extending through the stage table can affect travel and damage the stage.

Applied loads should be symmetrically distributed whenever possible (i.e., the payload should be centered on the stage table and the entire stage should be centered on the support structure).

For a cantilevered load, first determine if it is a Horizontal or a Side cantilever system. Measure the cantilever length, then find the corresponding load value from [Figure 2-6](#).

The **Horizontal** curve assumes a horizontal stage orientation with the payload offset extending outwards along the surface of the tabletop.

The **Side** curve is for situations where the stage is mounted on its side and the offset load extends outwards in a direction normal to the tabletop surface.

Refer to [Figure 2-7](#) for clarification on Horizontal or Side orientations.

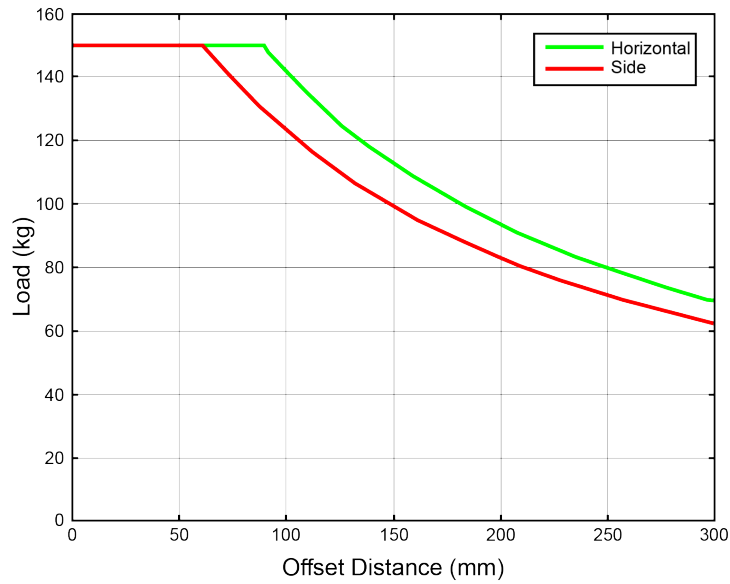

Figure 2-6: Cantilevered Load Capability of PRO280LM Series Stages

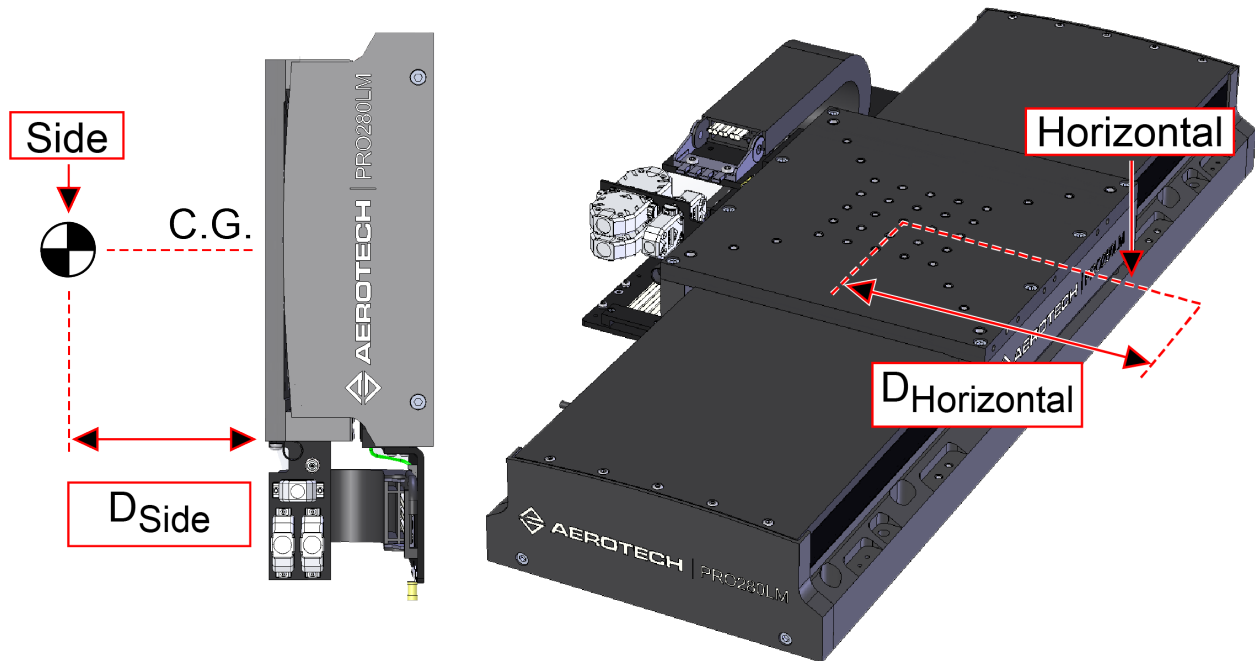

Figure 2-7: Stage Orientations

2.4.1. Speed Capability

To help ensure safety and prevent damage to the system, speed limitations are required for the PRO280LM. Achievable speeds are application-dependent and determined by factors such as travel length, payload, amplifier sizing and duty cycle. The Motor Sizer application supplied by Aerotech at <https://www.aerotech.com/resources/motor-sizer.aspx> can be used to estimate allowable speeds and accelerations based on these parameters. Consult with an Aerotech Applications Engineer to specify the system configuration for optimum performance.

This page intentionally left blank.

Chapter 3: Electrical Specifications and Installation



WARNING: Electrical installation must be performed by properly qualified personnel.

Electrical installation requirements will vary depending on product options. Installation instructions in this section are for PRO280LM stages equipped with standard Aerotech motors intended for use with an Aerotech motion control system. Contact Aerotech for further information regarding products that are otherwise configured.

Aerotech motion control systems are adjusted at the factory for optimum performance. When the PRO280LM is part of a complete Aerotech motion control system, setup usually involves connecting the PRO280LM to the appropriate drive chassis with the cables provided. Labels on the system components usually indicate the appropriate connections.

If system level integration was purchased, an electrical drawing showing system interconnects has been supplied with the system (separate from this documentation).

The electrical wiring from the motor and encoder are integrated at the factory. Refer to the sections that follow for standard motor wiring and connector pinouts.



WARNING: Applications requiring access to the stage while it is energized will require additional grounding and safeguards. The System Integrator or qualified installer is responsible for determining and meeting all safety and compliance requirements necessary for the integration of this stage into the final application.



DANGER: Remove power before connecting or disconnecting electrical components or cables. Failure to do so may cause electric shock or damage to the equipment.



WARNING: Operator access to the base and tabletop must be restricted while connected to a power source. Failure to do so may cause electric shock.

3.1. Motor and Feedback Connectors

Stages equipped with standard motors and encoders come from the factory completely wired and assembled.

NOTE: Refer to the other documentation accompanying your Aerotech equipment. Call your Aerotech representative if there are any questions on system configuration.

NOTE: If using standard Aerotech motors and cables, motor and encoder connection adjustments are not required.

The protective ground connection of the PRO280LM provides motor frame ground protection only. Additional grounding and safety precautions are required for applications requiring access to the stage while it is energized. The System Integrator or qualified installer is responsible for determining and meeting all safety and compliance requirements necessary for the integration of this stage into the final application.



DANGER: Remove power before connecting or disconnecting electrical components or cables. Failure to do so may cause electric shock or damage to the equipment.



WARNING: The protective ground connection must be properly installed to minimize the possibility of electric shock.



WARNING: For stages with the -CMS0 option: Ground wire connection points are provided at the tabletop and stage base. A user-supplied ground wire is recommended and may be useful in the final application to reduce noise or provide additional grounding for customer supplied equipment. Refer to [Figure 3-1](#) for ground connection points.



WARNING: Operator access to the base and tabletop must be restricted while connected to a power source. Failure to do so may cause electric shock.



CAUTION: The stage controller must provide over-current and over-speed protection. Failure to do so may result in permanent damage to the motor and stage components.

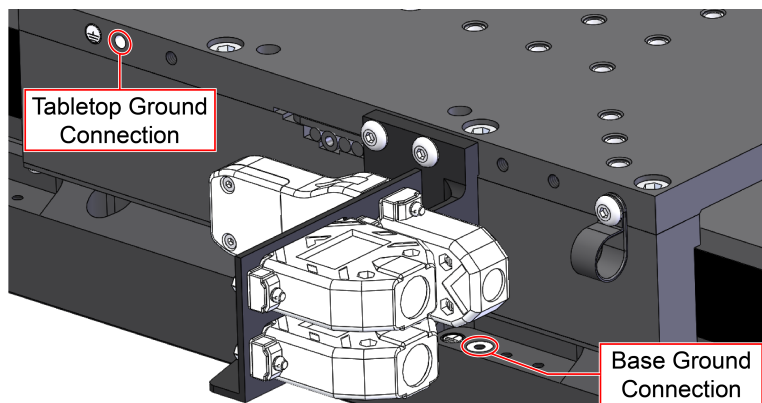

Figure 3-1: Ground Connection Points for the -CMS0 Option

Table 3-1: Motor Connector Pinout

Pin	Description	Connector
Case	Shield connection	
A1	Motor Phase A	
A2	Motor Phase B	
A3	Motor Phase C	
1	Reserved	
2	Reserved	
3	Reserved	
4	Reserved	
5	Reserved	
A4	Frame ground (motor protective ground)	

Table 3-2: Mating Connector Part Numbers for the Motor Connector

Mating Connector	Aerotech P/N	Third Party P/N
Backshell	ECK00656	Amphenol #17E-1726-2
Sockets [QTY. 4]	ECK00659	ITT Cannon #DM53744-6
Connector	ECK00657	ITT Cannon #DBM9W4SA197

Table 3-3: Feedback Connector Pinout (-E1 and -E2 Options)

Pin	Description	Connector
Case	Shield connection	
1	Reserved	
2	Over-Temperature Thermistor sensor	
3	+5 V supply input for feedback devices	
4	Reserved	
5	Hall Effect sensor, phase B	
6	Marker-N	
7	Marker	
8	Reserved	
9	Reserved	
10	Hall Effect sensor, phase A	
11	Hall Effect sensor, phase C	
12	Positive (CW) hardware limit	
13	Reserved	
14	Cosine	
15	Cosine-N	
16	+5 V power supply	
17	Sine	
18	Sine-N	
19	Reserved	
20	Common ground to limit switch	
21	Common ground to encoder power	
22	Reserved	
23	Reserved	
24	Negative (CCW) hardware limit	
25	Reserved	

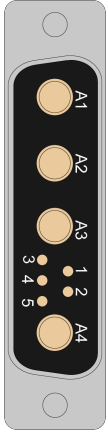
Table 3-4: Mating Connector Part Numbers for the Feedback Connector

Mating Connector	Aerotech P/N	Third Party P/N
Backshell	ECK00656	Amphenol 17E-1726-2
Connector	ECK00300	FCI DB25S064TLF

Table 3-5: Feedback Connector Pinout (-E3 Option)

Pin	Description	Connector
Case	Shield connection	
1	Reserved	
2	Over-Temperature Thermistor sensor	
3	+5 V supply input for feedback devices	
4	Reserved	
5	Hall Effect sensor, phase B	
6	Clock -	
7	Clock +	
8	Data -	
9	Reserved	
10	Hall Effect sensor, phase A	
11	Hall Effect sensor, phase C	
12	Reserved	
13	Reserved	
14	Reserved	
15	Reserved	
16	+5 V power supply	
17	Reserved	
18	Reserved	
19	Data +	
20	Common ground	
21	Common ground	
22	Reserved	
23	Reserved	
24	Reserved	
25	Reserved	

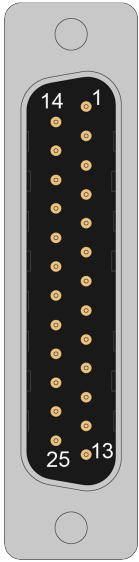
Table 3-6: Mating Connector Part Numbers for the Feedback Connector

Mating Connector	Aerotech P/N	Third Party P/N
Backshell	ECK00656	Amphenol 17E-1726-2
Connector	ECK00300	FCI DB25S064TLF

Table 3-7: General Motor Connector Pinout (for Z or T Axes)

Pin	Description	Wire Gauge AWG [mm ²]	Connector
Case	Shield connection	16 [1.31]	
A1	Motor Phase A	16 [1.31]	
A2	Motor Phase B	16 [1.31]	
A3	Motor Phase C	16 [1.31]	
1	Reserved	--	
2	Reserved	--	
3	Reserved	--	
4	Reserved	--	
5	Reserved	--	
A4	Frame ground (motor protective ground)	16 [1.31]	

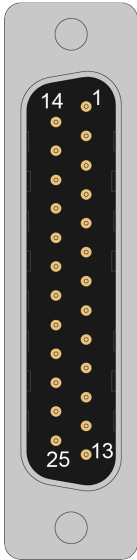
Table 3-8: Mating Connector Part Numbers for the Motor Connector

Mating Connector	Aerotech P/N	Third Party P/N
Backshell	ECK00656	Amphenol #17E-1726-2
Sockets [QTY. 4]	ECK00659	ITT Cannon #DM53744-6
Connector	ECK00657	ITT Cannon #DBM9W4SA197

Table 3-9: General Feedback Connector Pinout (for Z or T axes)

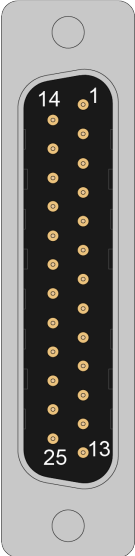
Pin	Description	Wire Gauge AWG [mm ²]	Connector
Case	Shield connection	26 [0.129]	
1	Reserved	26 [0.129]	
2	Over-Temperature Thermistor sensor	26 [0.129]	
3	+5 V supply input for feedback devices	26 [0.129]	
4	Reserved	--	
5	Hall Effect sensor, phase B	26 [0.129]	
6	Marker-N	26 [0.129]	
7	Marker	26 [0.129]	
8	Reserved	--	
9	Reserved	--	
10	Hall Effect sensor, phase A	26 [0.129]	
11	Hall Effect sensor, phase C	26 [0.129]	
12	Positive (CW) hardware limit	26 [0.129]	
13	Reserved/Brake ⁻⁽¹⁾	26 [0.129]	
14	Cosine	26 [0.129]	
15	Cosine-N	26 [0.129]	
16	+5 V power supply	26 [0.129]	
17	Sine	26 [0.129]	
18	Sine-N	26 [0.129]	
19	Reserved	--	
20	Common ground to limit switch	26 [0.129]	
21	Common ground to encoder power	26 [0.129]	
22	Reserved	--	
23	Reserved	--	
24	Negative (CCW) hardware limit	26 [0.129]	
25	Reserved/Brake ⁺⁽¹⁾	26 [0.129]	

1. BRAKE pins on Z or T axis, otherwise Reserved

Table 3-10: Mating Connector Part Numbers for the Feedback Connector

Mating Connector	Aerotech P/N	Third Party P/N
Backshell	ECK00656	Amphenol 17E-1726-2
Connector	ECK00300	FCI DB25S064TLF

3.2. Motor and Feedback Wiring

Shielded cables are required for the motor and feedback connections.

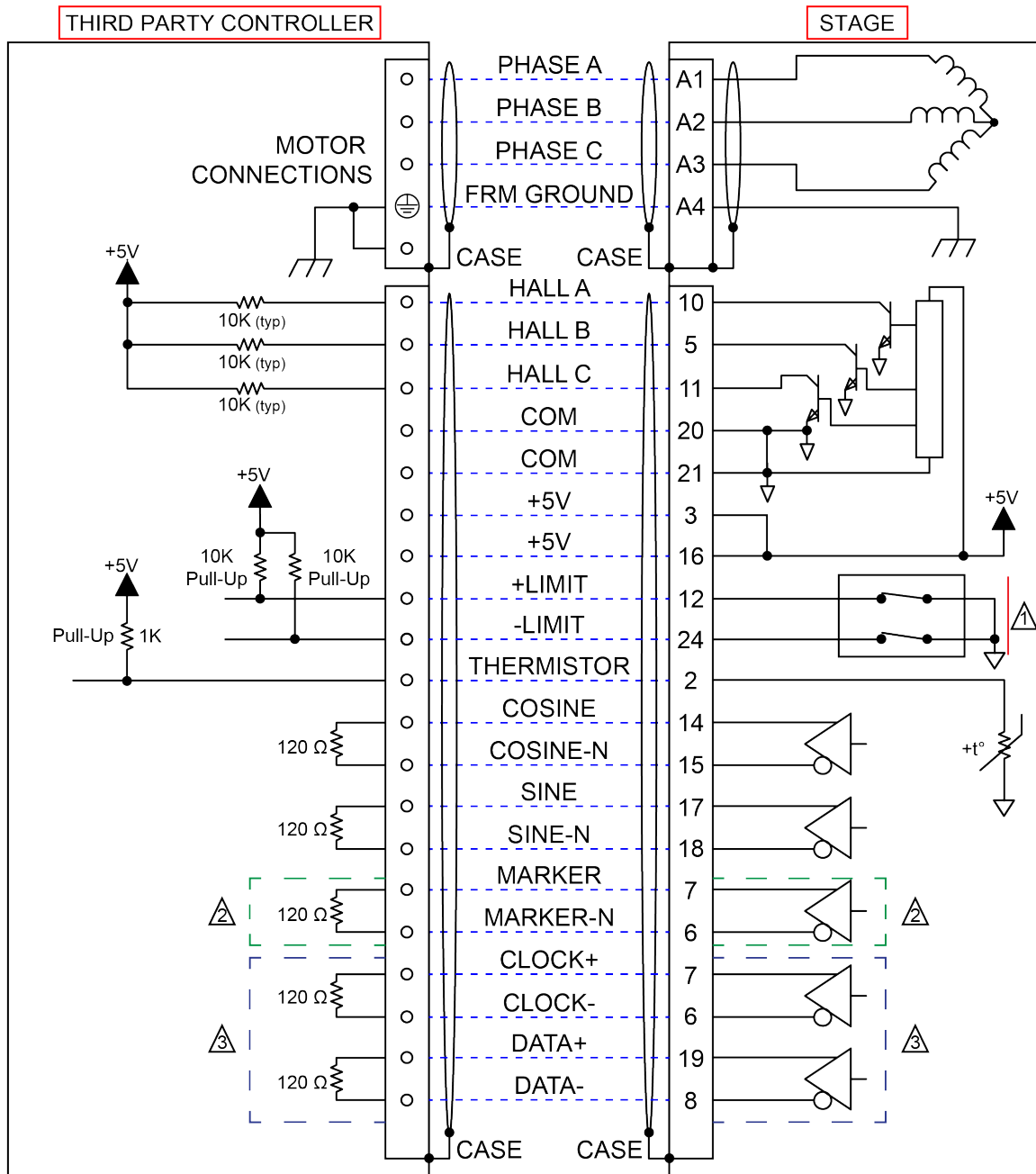

- ⚠ Stage over-travel limits are configured N.C. at the factory
- ⚠ -E1 and -E2 Incremental Encoder Option
- ⚠ -E3 Absolute Encoder Option

Figure 3-2: Motor and Feedback Wiring

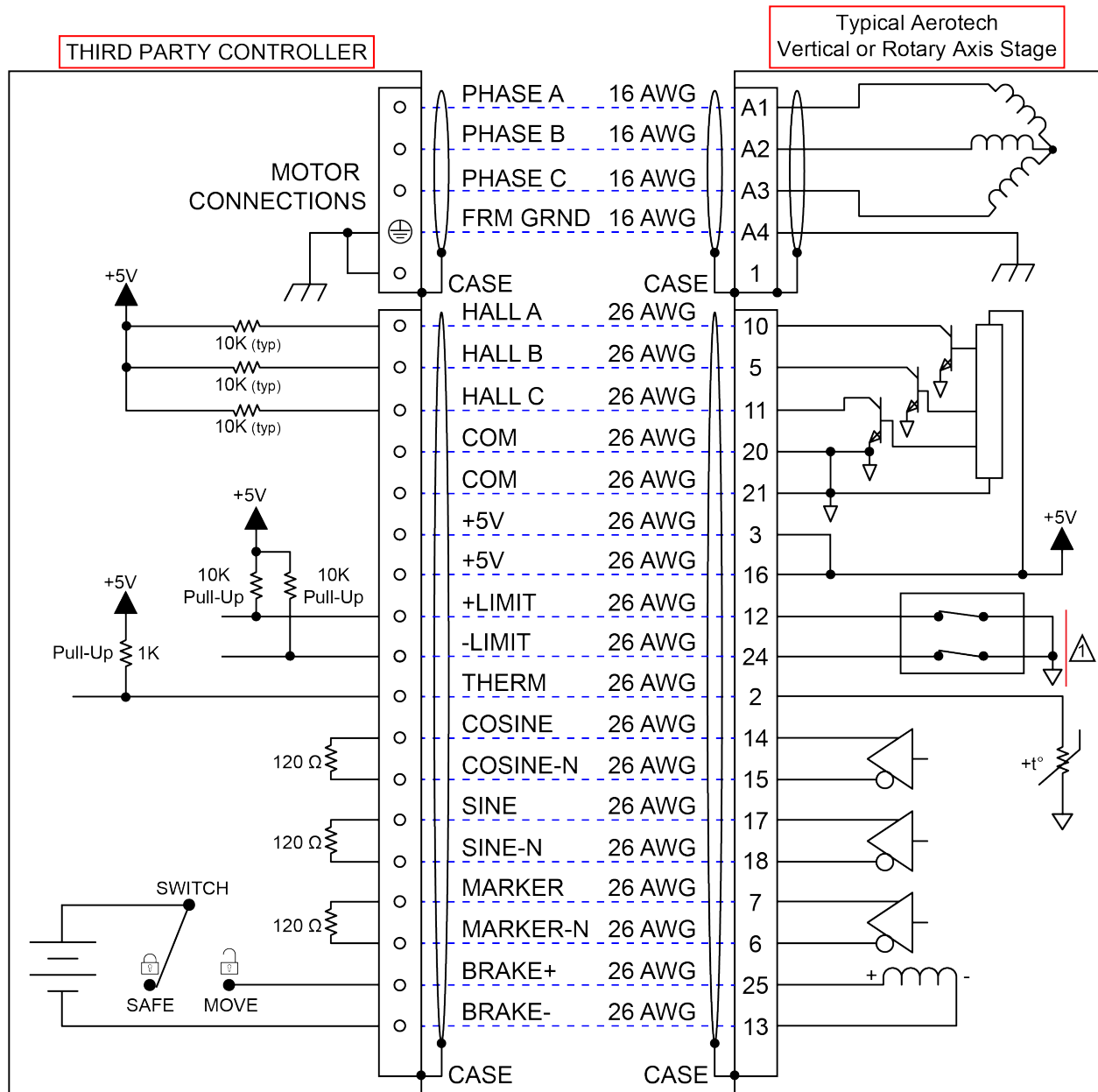

Stage over-travel limits are configured N.C. at the factory

Figure 3-3: Motor and Feedback Wiring for a Typical Vertical or Rotary Axis Stage

3.3. Motor and Feedback Specifications

Table 3-11: Feedback Specifications

Hall-Effect Sensors Specifications	
Supply Voltage	5 V \pm 5%
Supply Current	50 mA
Output Type	Open Collector
Output Voltage	24 V max (pull up)
Output Current	5 mA (sinking)

Thermistor Specifications	
Polarity	Logic "0" (no fault)
	Logic "1" (over-temperature fault)
Cold Resistance	\sim 100 Ω
Hot Resistance	\sim 10 K
Note: 1K pull-up to +5V recommended.	

Encoder Specifications	
Supply Voltage	5 V \pm 5%
Supply Current	250 mA Typical
Output Signals	Sinusoidal Type (Incremental Encoder): 1 V _{pk-pk} into 120 Ω Load (differential signals SIN+, SIN-, COS+, COS- are .5 V _{pk-pk} relative to ground.)
	Digital Output (Incremental Encoder): RS422/485 compatible
	Serial Output (Absolute Encoder): EnDat 2.2 with 36 bit word

Limit Switch Specifications	
Supply Voltage	5 V \pm 5%
Supply Current	25 mA
Output Type	Open Collector
Output Voltage	5 V
Output Current	10 mA (sinking)
Output Polarity	Normally Closed (NC)
	<ul style="list-style-type: none"> Sinks current to ground (Logic "0") when not in limit High impedance (Logic "1") when in limit Requires external pull-up to +5 V (10 kΩ recommended)
Notes:	
<ul style="list-style-type: none"> If the PRO280LM is driven beyond the electrical limit, it will encounter a mechanical stop. Impacting the mechanical stop could cause damage to the stage even at low speeds. Hall effect, encoder, and limit switch 5 VDC supplies are connected by the wiring system of the stage. 	

Table 3-12: PRO280LM Linear Motor Specifications (BLMH-262-A)

		BLMH-262
Performance Specifications (1)(5)		
Continuous Force, 1.4 bar (20 psi) (2)	N (lb)	437.1 (98.3)
Continuous Force, No Forced Cooling (2)	N (lb)	266.2 (59.9)
Electrical Specifications(5)		
Winding Designation	A / B	-A
BEMF Constant (line-line, max)	V/(m/s) (V/(in/s))	64.42 (1.64)
Continuous Current 1.4 bar (20 psi) (2)	A_{pk} (A_{rms})	7.80 (5.52)
Continuous Current, No Forced Cooling (2)	A_{pk} (A_{rms})	4.75 (3.36)
Peak Current, Stall (3)	A_{pk} (A_{rms})	31.20 (22.06)
Force Constant, Sine Drive (4) (8)	N/A_{pk} (lb/ A_{pk})	56.04 (12.60)
	N/A_{rms} (lb/ A_{rms})	79.26 (17.82)
Motor Constant (2)(4)	N/\sqrt{W} (lb/ \sqrt{W})	20.24 (4.55)
Resistance, 25°C (line-line)	Ω	7.3
Inductance (line-line)	mH	4.60
Thermal Resistance, 1.4 bar (20 psi)	°C/W	0.21
Thermal Resistance, No Forced Cooling	°C/W	0.58
Maximum Bus Voltage	V_{DC}	340
Magnetic Pole Pitch	mm (in)	30.00 (1.18)
1. Performance is dependent upon heat sink configuration, system cooling conditions, and ambient temperature 2. Values shown @ 100°C rise above a 25°C ambient temperature, with motor mounted to the specified aluminum heat sink. 3. Peak force assumes correct rms current; consult Aerotech. 4. Force constant and motor constant specified at stall 5. All performance and electrical specifications ±10% 6. Maximum winding temperature is 125°C. 7. Ambient operating temperature range 0 °C - 25 °C; consult Aerotech for performance in elevated ambient temperatures 8. All Aerotech amplifiers are rated A_{pk} ; use force constant in N·m/ A_{pk} when sizing.		



WARNING : The stage forcer temperature may exceed 75°C.

Table 3-13: Encoder Specifications

Encoder Option	Fundamental Signal Period	Digital Resolution
-E1	20 μ m	--
-E1 (with x4000 Interpolation ¹)		5 nm
-E1 (with x16000 Interpolation ¹)		1.25 nm
-E2 ¹		100 nm
-E3	--	1 nm

1. Quadrature decoding included in interpolated resolution calculations.

3.4. Limits, Marker, and Machine Direction

Aerotech stages are configured to have positive and negative "machine" directions. The machine direction defines the phasing of the feedback and motor signals and is dictated by the stage wiring (refer to [Section 3.5](#) for Motor and Feedback phasing information). Programming direction of a stage is set by the controller that is used to move the stage. Programming direction is typically selectable in the controller, while machine direction is hardwired in the stage. [Figure 3-4](#) shows the machine direction of PRO280LM stages.

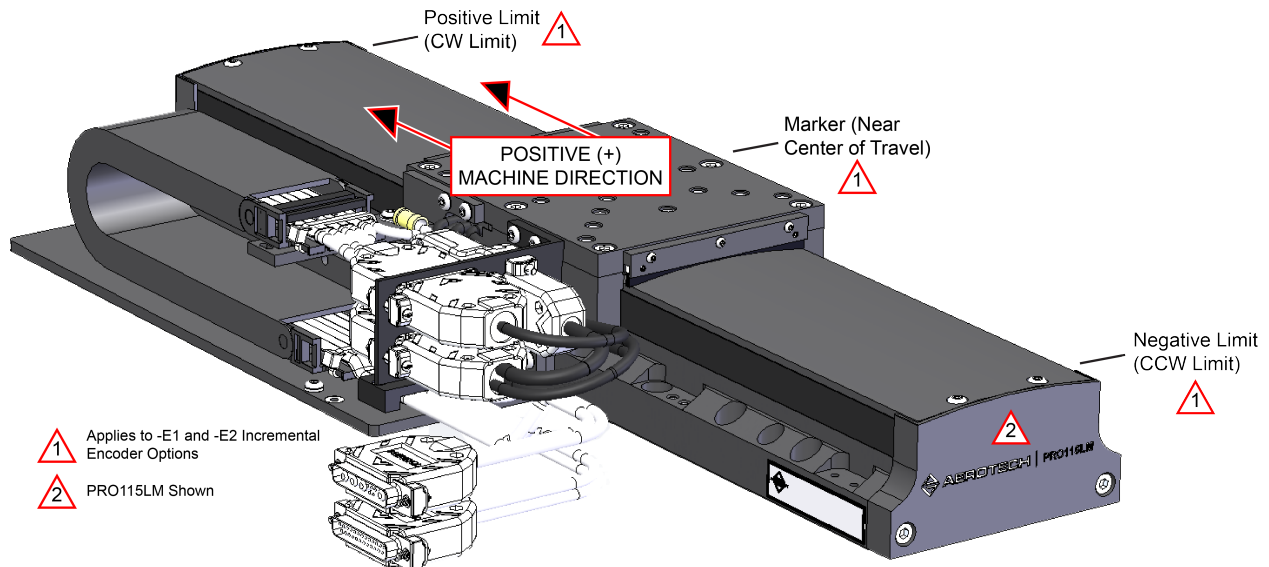

Figure 3-4: Machine Direction

3.5. Motor and Feedback Phasing

Motor phase voltage is measured relative to the virtual wye common point.

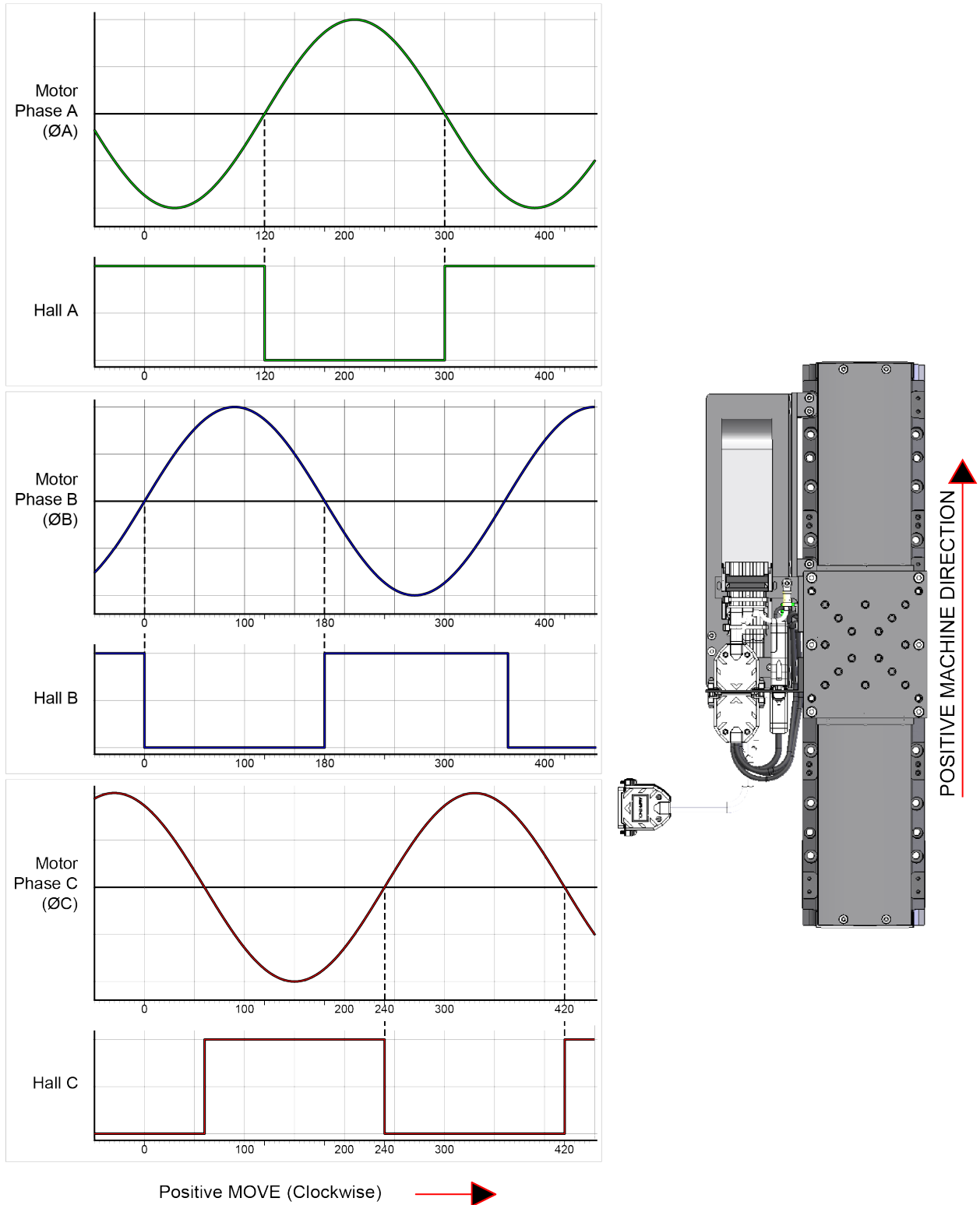

Figure 3-5: Hall Phasing

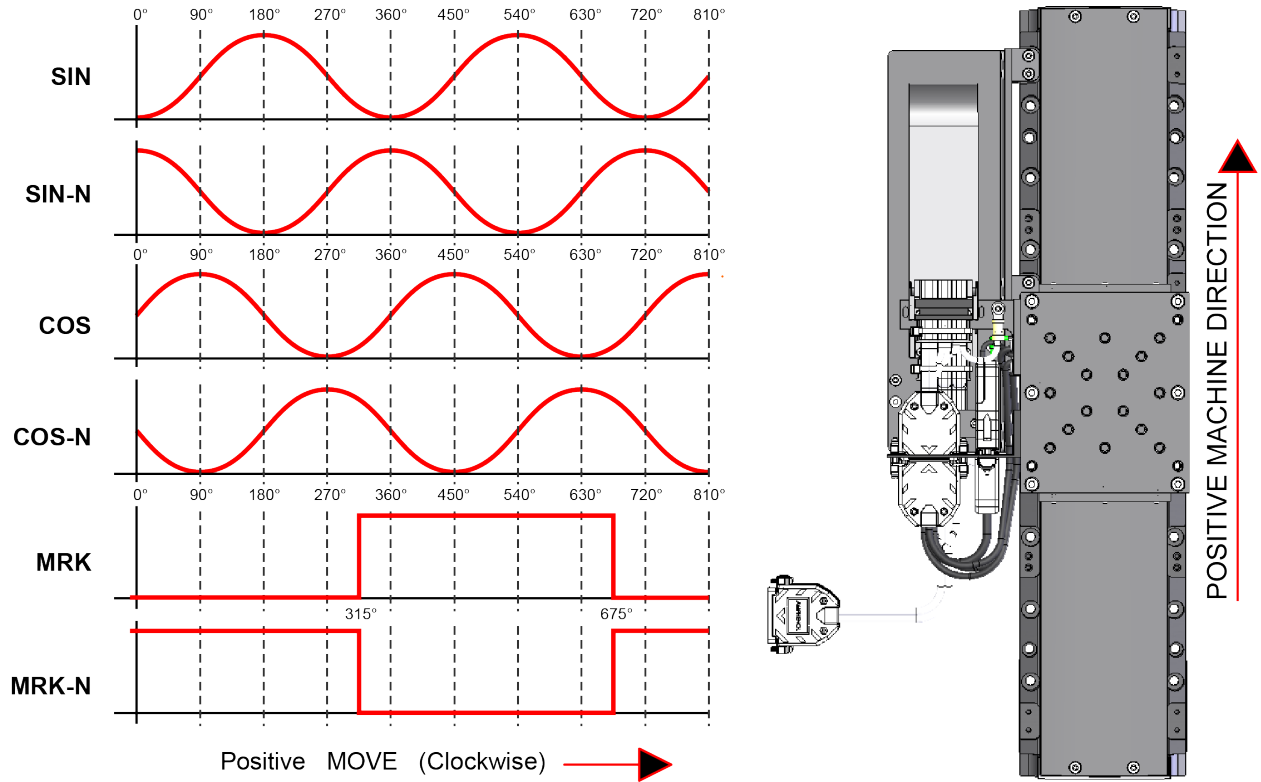

Figure 3-6: Analog Encoder Phasing Reference Diagram (-E1 Incremental Encoder)

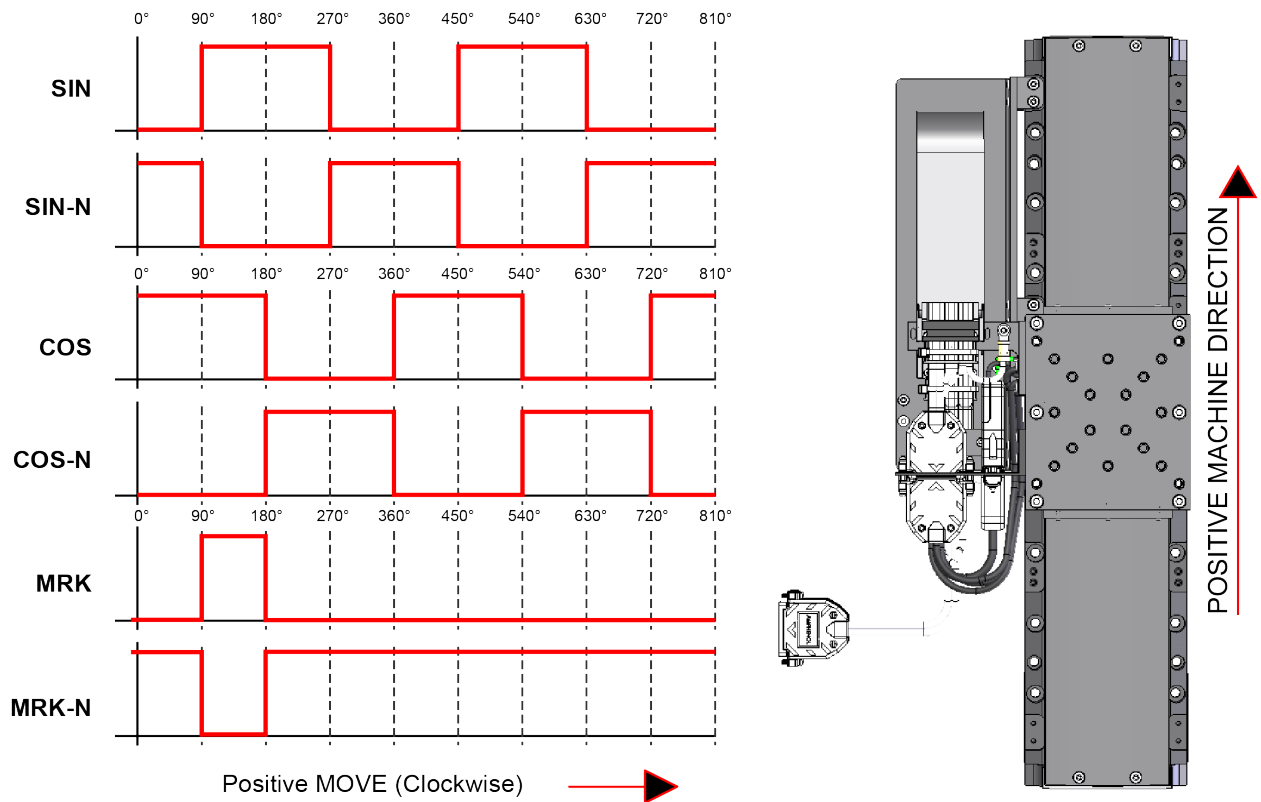

Figure 3-7: Encoder Phasing Reference Diagram (-E2 Incremental Encoder)

Chapter 4: Maintenance

NOTE: If the bearing area is not kept free of foreign matter and moisture, the performance and life expectancy of the stage will be reduced.



DANGER: To minimize the possibility of bodily injury or death, disconnect all electrical power prior to performing any maintenance or making adjustments to the equipment.

4.1. Service and Inspection Schedule

Inspect the PRO280LM at least once per month. A longer or shorter inspection interval may be required depending on the application and conditions, such as the duty cycle, speed, and environment.

In general, stages operating in a clean environment should be cleaned and lubricated annually or every 500 km (whichever comes first). For stages operating under conditions involving excessive debris, the stage should be cleaned every six months. For high-speed applications (those near max speed at a duty cycle of 50%), frequent maintenance with standard lubricants is required.

Monthly inspections should include but not be limited to:

- Visually inspect the stage and cables.
- Re-tighten loose connectors.
- Replace or repair damaged cables.
- Clean the PRO280LM and any components and cables as needed.
- Repair any damage before operating the PRO280LM.
- Inspect and perform an operational check on all safeguards and protective devices.

4.2. Cleaning and Lubrication

When cleaning and/or lubricating components of the PRO280LM series stages:

1. Be sure to use a clean, dry, soft, lint-free cloth for cleaning.
2. Before using a cleaning solvent on any part of the PRO280LM, blow away small particles and dust with clean, dry, compressed air.
3. Take the opportunity during the lubrication procedure to inspect the motion guides or bearings for any damage or signs of wear.
4. In applications that have multiple stages bolted together to form multi-axis systems, the orthogonality may be lost if the stage tables of the support stages are loosened. Precision aligned stages should not be loosened or disassembled.
5. Further disassembly of the stage is not recommended because proper assembly and calibration can only be done at the factory. In addition, an autocollimator is required for post assembly verification to maintain warranties. Contact Aerotech for more information.



DANGER: To minimize the possibility of bodily injury or death, disconnect all electrical power prior to performing any maintenance or making adjustments to the equipment.

Cleaning

If a solvent is necessary for cleaning the stage, Aerotech recommends using isopropyl alcohol. Harsher solvents, such as acetone, may damage the plastic and end caps on the bearing trucks.



WARNING: Make sure that all solvent has completely evaporated before attempting to move the stage.

Lubrication

Aerotech recommends that you use only Kluberplex BEM 34-132 as the standard lubricant for second generation PRO280LM stages. Second generation stages can be distinguished from first generation stages by the curved hardcover on the second generation stage.



WARNING: First generation stages were manufactured with THK AFE-CA grease as the standard lubricant. THK AFE-CA grease is not chemically compatible with Kluberplex BEM 34-132 and the two should not be used interchangeably. First generation stages in the field should continue to use THK AFE-CA grease for regular maintenance lubrication.

For high-speed applications (i.e., near maximum speed at a duty cycle of 50%), frequent maintenance with standard lubricants is required.

If the application process uses only a small portion of travel for most of the duty cycle, periodically drive the stage through full travel to redistribute the lubrication in the bearings.

NOTE: During the lubrication procedure, inspect the linear motion guides for any damage or signs of wear.

The lubrication and cleaning process is outlined in the steps that follow.



DANGER: To minimize the possibility of bodily injury or death, disconnect all electrical power prior to performing any maintenance or making adjustments to the equipment.

1. Remove power to the stage.
2. Remove the cover attached to the rear endplate (Figure 4-1).
3. Remove the screws on the edges of the hardcover (Figure 4-2) and slide it out from under the stage (Figure 4-3). This can be done without removing the table.
4. Remove any accumulated dust or debris from the inside of the assembly.
5. Remove any dirty or dried lubricant from the linear bearing rails. Use a clean, lint-free cloth with a side-to-side motion. A swab soaked in Isopropyl Alcohol can be used (carefully) to remove stubborn debris.
6. Apply a thin, continuous film of lubricant to the linear bearing guides. A good quality, natural bristle artist's brush makes an excellent applicator.
7. Manually move the stage to the opposite end of travel. This will work the grease into the linear bearing guides.
8. Repeat steps 3 through 5 for any areas covered by the original table position.
9. Refasten the hardcover. First Generation Stages **Only:** Torque the hardcover screws to 36 - 42 in-lbs to ensure proper support.

NOTE: For GEN II PRO series stages with travel lengths greater than or equal to 800 mm. The hardcover mounting surfaces in the stage endplates have been machined in such a way as to negate the natural sag due to gravity of the hardcover. As the mounting screws are tightened, the cover gently conforms to the shape of the endplates. Ensure that the cover is fully seated on the endplate mounting surfaces before operating the stage. Check each mounting screw for full engagement by tightening the screw while holding the long side of a standard hex wrench.

10. Restore power to the stage; drive the stage table back to its original position to redistribute lubricants.

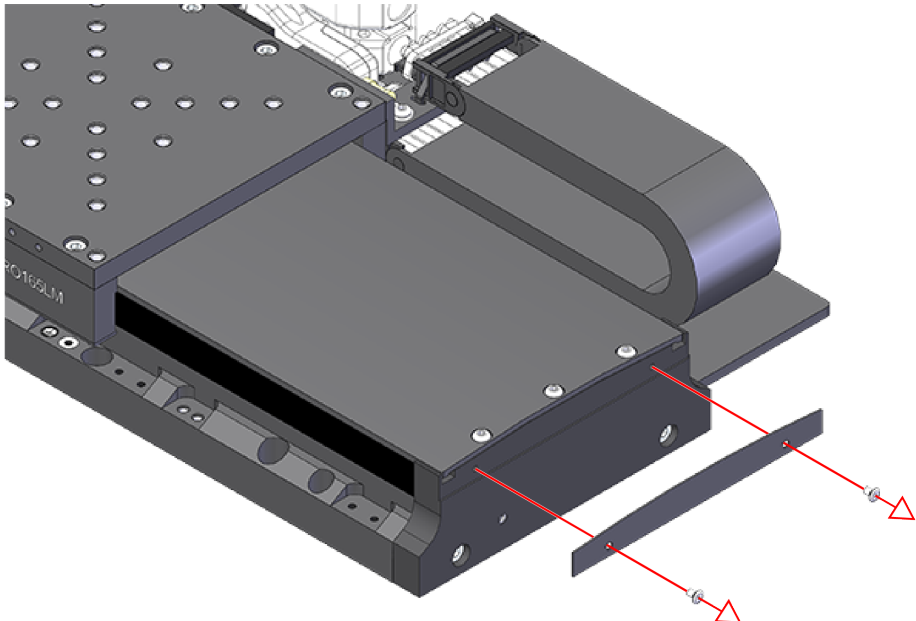
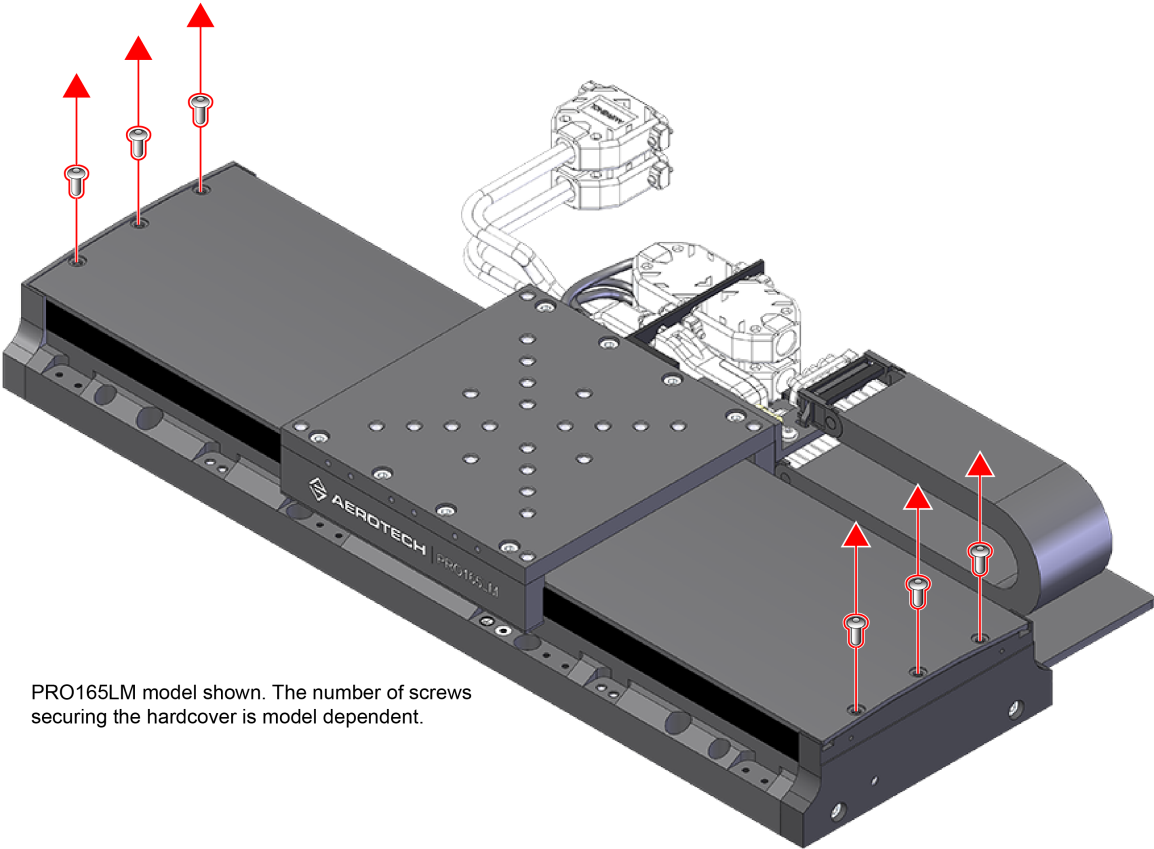

Figure 4-1: Endplate Cover Removal (Step 2)



PRO165LM model shown. The number of screws securing the hardcover is model dependent.

Figure 4-2: Hardcover Screw Removal (Step 3)

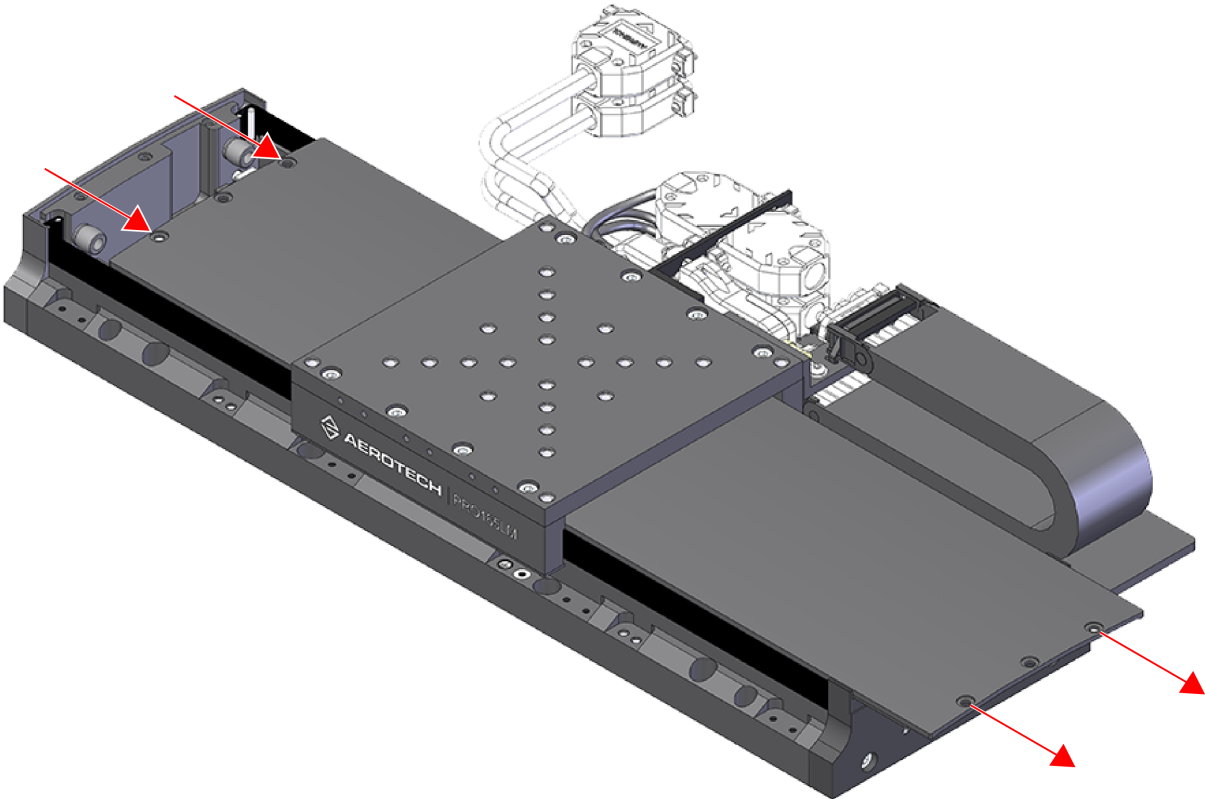

Figure 4-3: Hardcover Removal (Step 3)

4.3. Troubleshooting

Symptom	Possible Cause and Solution
Stage will not move	Shipping restraints still installed. Remove the red anodized shipping brackets. In Limit condition. Check limits (refer to Chapter 3) and refer to the Controller documentation for polarity and compatibility requirements (Example: voltage requirements). Controller trap or fault (refer to the Controller documentation).
Stage moves uncontrollably	Encoder (sine and cosine) signal connections (refer to Chapter 3 and Controller documentation). Motor Connections (refer to Chapter 3 and the Controller documentation).
Stage oscillates or squeals	Gains misadjusted (refer to the Controller documentation). Encoder signals (refer to the Controller documentation).

Appendix A: Warranty and Field Service

Aerotech, Inc. warrants its products to be free from harmful defects caused by faulty materials or poor workmanship for a minimum period of one year from date of shipment from Aerotech. Aerotech's liability is limited to replacing, repairing or issuing credit, at its option, for any products that are returned by the original purchaser during the warranty period. Aerotech makes no warranty that its products are fit for the use or purpose to which they may be put by the buyer, whether or not such use or purpose has been disclosed to Aerotech in specifications or drawings previously or subsequently provided, or whether or not Aerotech's products are specifically designed and/or manufactured for buyer's use or purpose. Aerotech's liability on any claim for loss or damage arising out of the sale, resale, or use of any of its products shall in no event exceed the selling price of the unit.

THE EXPRESS WARRANTY SET FORTH HEREIN IS IN LIEU OF AND EXCLUDES ALL OTHER WARRANTIES, EXPRESSED OR IMPLIED, BY OPERATION OF LAW OR OTHERWISE. IN NO EVENT SHALL AEROTECH BE LIABLE FOR CONSEQUENTIAL OR SPECIAL DAMAGES.

Return Products Procedure

Claims for shipment damage (evident or concealed) must be filed with the carrier by the buyer. Aerotech must be notified within thirty (30) days of shipment of incorrect material. No product may be returned, whether in warranty or out of warranty, without first obtaining approval from Aerotech. No credit will be given nor repairs made for products returned without such approval. A "Return Materials Authorization (RMA)" number must accompany any returned product(s). The RMA number may be obtained by calling an Aerotech service center or by submitting the appropriate request available on our website (www.aerotech.com). Products must be returned, prepaid, to an Aerotech service center (no C.O.D. or Collect Freight accepted). The status of any product returned later than thirty (30) days after the issuance of a return authorization number will be subject to review.

Visit <https://www.aerotech.com/global-technical-support.aspx> for the location of your nearest Aerotech Service center.

Returned Product Warranty Determination

After Aerotech's examination, warranty or out-of-warranty status will be determined. If upon Aerotech's examination a warranted defect exists, then the product(s) will be repaired at no charge and shipped, prepaid, back to the buyer. If the buyer desires an expedited method of return, the product(s) will be shipped collect. Warranty repairs do not extend the original warranty period.

Fixed Fee Repairs - Products having fixed-fee pricing will require a valid purchase order or credit card particulars before any service work can begin.

All Other Repairs - After Aerotech's evaluation, the buyer shall be notified of the repair cost. At such time the buyer must issue a valid purchase order to cover the cost of the repair and freight, or authorize the product(s) to be shipped back as is, at the buyer's expense. Failure to obtain a purchase order number or approval within thirty (30) days of notification will result in the product(s) being returned as is, at the buyer's expense.

Repair work is warranted for ninety (90) days from date of shipment. Replacement components are warranted for one year from date of shipment.

Rush Service

At times, the buyer may desire to expedite a repair. Regardless of warranty or out-of-warranty status, the buyer must issue a valid purchase order to cover the added rush service cost. Rush service is subject to Aerotech's approval.

On-site Warranty Repair

If an Aerotech product cannot be made functional by telephone assistance or by sending and having the customer install replacement parts, and cannot be returned to the Aerotech service center for repair, and if Aerotech determines the problem could be warranty-related, then the following policy applies:

Aerotech will provide an on-site Field Service Representative in a reasonable amount of time, provided that the customer issues a valid purchase order to Aerotech covering all transportation and subsistence costs. For warranty field repairs, the customer will not be charged for the cost of labor and material. If service is rendered at times other than normal work periods, then special rates apply.

If during the on-site repair it is determined the problem is not warranty related, then the terms and conditions stated in the following "On-Site Non-Warranty Repair" section apply.

On-site Non-Warranty Repair

If any Aerotech product cannot be made functional by telephone assistance or purchased replacement parts, and cannot be returned to the Aerotech service center for repair, then the following field service policy applies:

Aerotech will provide an on-site Field Service Representative in a reasonable amount of time, provided that the customer issues a valid purchase order to Aerotech covering all transportation and subsistence costs and the prevailing labor cost, including travel time, necessary to complete the repair.

Service Locations

<http://www.aerotech.com/contact-sales.aspx?mapState=showMap>

USA, CANADA, MEXICO	CHINA	GERMANY
Aerotech, Inc. Global Headquarters Phone: +1-412-967-6440 Fax: +1-412-967-6870	Aerotech China Full-Service Subsidiary Phone: +86 (21) 5508 6731	Aerotech Germany Full-Service Subsidiary Phone: +49 (0)911 967 9370 Fax: +49 (0)911 967 93720
TAIWAN	UNITED KINGDOM	
Aerotech Taiwan Full-Service Subsidiary Phone: +886 (0)2 8751 6690	Aerotech United Kingdom Full-Service Subsidiary Phone: +44 (0)1256 855055 Fax: +44 (0)1256 855649	

Have your customer order number ready before calling.

Appendix B: Technical Changes

Revision	Description
1.04.00	Dimension drawing updated: Section 2.2 .
1.03.00	Product update
1.02.00	<ul style="list-style-type: none">• Product redesign• Safety information updated• Order and part number specifications updated: Chapter 1• Added ThermoComp™ information
1.01.00	Revision changes have been archived. If you need a copy of this revision, contact Aerotech
1.00.00	Global Technical Support.

This page intentionally left blank.

Index

	2		isopropyl alcohol	42
2010		9		
	A		L	
Accuracy and Temperature Effects		13	label	17
acetone (caution)		42	Lifting Instructions	19
Altitude		13	Limit Switch Specifications	36
Ambient Temperature		13	lubricants	
Attaching the Payload		24	vacuum operation	16
	B		Lubrication	42
BLMH-262-A Motor Specifications		37	lubrication schedule	41
Braycote® 602EF		16		
	C		M	
cleaning			Maximum Achievable Velocity	25
mounting surface		23	Motor Specifications	37
Cleaning		42	mounting surface	
cleaning solvent		42	cleaning	23
	D		securing stage	23
Dimensions		20	multiaxis combinations	42
	E			
EN 60204-1		9	P	
EN ISO 12100		9	part number	17
Encoder Specifications		36	Possible Cause	46
	G		Protection Rating	13
Global Technical Support		2	protective ground connection	28
grease		16		
	H		R	
Hall-Effect Sensors Specifications		36	red anodized aluminum	17
Humidity		13		
	I		S	
inspection schedule		41	serial number	17
Inspection Schedule		41	service schedule	41
			shimming	23
			shipping brackets	17
			Shipping Brackets	17
			Solution	46
			Specifications	14
			Speed Limitations	25

stabilizing stage	17
stage	
distortion	23
stabilizing	17
Support	2
Symptom	46
T	
Technical Support	2
Thermistor Specifications	36
U	
Unpacking and Handling the Stage	17
V	
vacuum	16
vacuum guidelines	16
Vibration	13
W	
Warranty and Field Service	47