



Brushless Rotary Motors

BM Series

High Torque, Low Maintenance

Our BM servomotors use permanent rare-earth magnets with a skewed, low-inertia rotor design to deliver high torque output, excellent torque-to-inertia ratio, minimal torque ripple and smooth velocity performance.

Unlike DC brush-type servomotors, BM motors feature a low-maintenance brushless design, making them ideal for critical applications that cannot tolerate downtime.

A variety of standard models and configurations are available for fast delivery, and we can engineer custom variants to satisfy your unique application needs.



KEY FEATURES:

- ◆ Available in **8 MODELS** with torque ranging from 0.16 N·m to 27.6 N·m
- ◆ Configurable with optional **FAIL-SAFE HOLDING BRAKE**
- ◆ Features optional **IP65-LEVEL CONSTRUCTION** for use in harsh environments
- ◆ Available in standard **NEMA FRAME SIZES**
- ◆ Follows the **2011/65/EU ROHS 2** directive

BM SERIES SPECIFICATIONS

Model	Units	BM22	BM75	BM130	BM200
Performance Specifications^{1,2}					
Stall Torque, Continuous ³	N·m	0.16	0.51	1.02	1.45
Peak Torque ⁴	N·m	0.48	1.3	2.5	3.6
Rated Speed	rpm	3000	4000	4000	4000
Rated Power Output, Continuous	W	50	192	333	455
Electrical Specifications²					
BEMF Constant (Line-Line, Max)	$V_{pk}/krpm$	3.9	9	19	18
Continuous Current, Stall ³	A_{pk}	4.9	9.0	6.9	10.3
	A_{rms}	3.5	6.4	4.9	7.3
Peak Current, Stall ⁴	A_{pk}	14.7	22.5	17.3	25.8
	A_{rms}	10.4	15.9	12.2	18.2
Torque Constant ⁵	$N·m/A_{pk}$	0.032	0.06	0.15	0.14
	$N·m/A_{rms}$	0.045	0.08	0.21	0.20
Motor Constant ^{5,5}	$N·m/\sqrt{W}$	0.038	0.055	0.101	0.131
Resistance, 25°C, (Line-Line)	Ω	0.67	1.0	2.0	1.1
Inductance (Line-Line)	mH	0.73	1.42	3.52	2.18
Maximum Bus Voltage	VDC	80	340		
Thermal Resistance	$^{\circ}C/W$	4.56	1.18	1.04	0.81
Number of Poles	-	8			
Mechanical Specifications					
Frame Size	NEMA	17	23		
Mass	kg	0.4	1.1	1.5	2.0
Mass with Brake	kg	N/A	1.7	2.1	2.6
Rotor Moment of Inertia	$kg·m^2$	2.00×10^{-6}	5.91×10^{-6}	1.00×10^{-5}	1.30×10^{-5}
Max. Radial Load	N	78	89		
Max. Axial Load	N	39	89		
Standards		2011/65/EU RoHS 2 Directive			

1. Performance is dependent upon heat sink configuration, system cooling conditions, and ambient temperature.

2. All performance and electrical specifications $\pm 10\%$.

3. Values shown @ 130°C rise above a 25°C ambient temperature, with motor mounted to a 305 mm x 305 mm x 12.7 mm aluminum heat sink.

4. Peak torque assumes correct rms current; consult Aerotech.

5. Torque constant and motor constant specified at stall.

BM SERIES SPECIFICATIONS

Model	Units	BM250	BM500	BM800	BM1400
Performance Specifications^{1,2}					
Stall Torque, Continuous ³	N·m	2.3	3.6	6.1	11.0
Peak Torque ⁴	N·m	5.7	9.1	15.3	27.6
Rated Speed	rpm	4000	4000	3000	3000
Rated Power Output, Continuous	W	739	1065	1446	2549
Electrical Specifications²					
BEMF Constant (Line-Line, Max)	$V_{pk}/krpm$	28	29	69	
Continuous Current, Stall ³	A_{pk}	10.3	17.5	11.9	20.5
	A_{rms}	7.2	12.4	8.4	14.5
Peak Current, Stall ⁴	A_{pk}	25.6	43.8	29.8	51.3
	A_{rms}	18.1	30.9	21.0	36.2
Torque Constant ⁵	$N\cdot m/A_{pk}$	0.22	0.21	0.51	0.54
	$N\cdot m/A_{rms}$	0.31	0.29	0.73	0.76
Motor Constant ^{3,5}	$N\cdot m/\sqrt{W}$	0.206	0.287	0.451	0.745
Resistance, 25°C, (Line-Line)	Ω	1.1	0.5	1.2	0.5
Inductance (Line-Line)	mH	2.74	1.42	3.8	1.7
Maximum Bus Voltage	VDC	340			
Thermal Resistance	°C/W	0.82	0.61	0.60	0.54
Number of Poles	-	8			
Mechanical Specifications					
Frame Size	NEMA	34		42	
Mass	kg	3.6	5.0	6.6	10.7
Mass with Brake	kg	4.4	5.8	8.1	12.2
Rotor Moment of Inertia	$kg\cdot m^2$	4.08×10^{-5}	7.57×10^{-5}	2.44×10^{-4}	5.60×10^{-4}
Max. Radial Load	N	178		222	
Max. Axial Load	N	89			
Standards		2011/65/EU RoHS 2 Directive			

1. Performance is dependent upon heat sink configuration, system cooling conditions, and ambient temperature.

2. All performance and electrical specifications $\pm 10\%$.

3. Values shown @130°C rise above a 25°C ambient temperature, with motor mounted to a 305 mm x 305 mm x12.7 mm aluminum heat sink.

4. Peak torque assumes correct rms current; consult Aerotech.

5. Torque constant and motor constant specified at stall.

BM SERIES ORDERING INFORMATION

NEMA Brushless Rotary Servomotor

BM22	NEMA 17 brushless rotary servomotor
BM75	NEMA 23 brushless rotary servomotor
BM130	NEMA 23 brushless rotary servomotor
BM200	NEMA 23 brushless rotary servomotor
BM250	NEMA 34 brushless rotary servomotor
BM500	NEMA 34 brushless rotary servomotor
BM800	NEMA 42 brushless rotary servomotor
BM1400	NEMA 42 brushless rotary servomotor

Connectors (Required)

-MS	Integral cable w/MS connector for Fbk and Mtr (-MS); not available for BM22
-D25	Integral cable w/D25 Fbk and 4D Mtr (-D25); only available on BM22, BM75, BM130, and BM200
-D25-9D	Integral cable w/D25 Fbk, 4D Mtr, and 9D Limit (-D25-9D); only available on BM75, BM130, and BM200
-D25-FLB	Integral cable w/D25 Fbk, Fly Leads for Mtr, and 9D Limit (-D25-FLB); only available on BM75, BM130, and BM200
-D25-5DU	Integral cable w/D25 Fbk, 5D Mtr, and 9D Limit (-D25-5DU); only available on BM75, BM130, and BM200
-D25-9D-CMS	Integral cable w/D25 Fbk, 4D Mtr, and 9D Limit - CMS Only (-D25-9D-CMS); only available on BM75, BM130, and BM200
-D25-4TS	Integral cable w/D25 Fbk, 4TS Mtr, and 9D Limit (-D25-4TS); only available on BM75, BM130, and BM200

Feedback (Required)

-E1000H	1000 lines/rev TTL incremental encoder w/Hall tracks (-E1000H); not available for BM22
-E2000H	2000 lines/rev TTL incremental encoder w/Hall tracks (-E2000H)
-E2500H	2500 lines/rev TTL incremental encoder w/Hall tracks (-E2500H); not available for BM22
-E5000H	5000 lines/rev TTL incremental encoder w/Hall tracks (-E5000H); not available for BM22
-E1000ASH	1000 lines/rev 1 Vpp incremental encoder w/Hall tracks (-E1000ASH); not available for BM22

Brake (Optional)

-BK	Holding Brake
------------	---------------

Note: Brake not available with BM22

Cable Type (Optional)

-HF	High flex cable; only available on BM75, BM130, and BM200
------------	---

Cable Length (dm; Optional)

-xx	Cable length in decimeters (3.8 dm is default); only available on BM75, BM130, and BM200
------------	--

BM SERIES ORDERING INFORMATION

Shaft Seal (Optional)

-NS Nitrile front shaft seal; only available on BM250, BM500, BM800 and BM1400

Vacuum Preparation (Optional)

-VAC6 Vacuum preparation to 10⁻⁶ Torr

Accessories (Optional)

MC-HPD25-M Connector; HPD motor power mate

MC-DB25-F Connector; DB25 motor feedback mate

MCM-3 Connector; MS motor power mate (BM75, BM130, BM200, BM250, BM500, BM800, BM1400)

MCF-3 Connector; MS motor feedback mate

Note: Accessories are ordered as separate line items.



BM SERIES SPECIFICATIONS

BM SERIES MOTOR PERFORMANCE

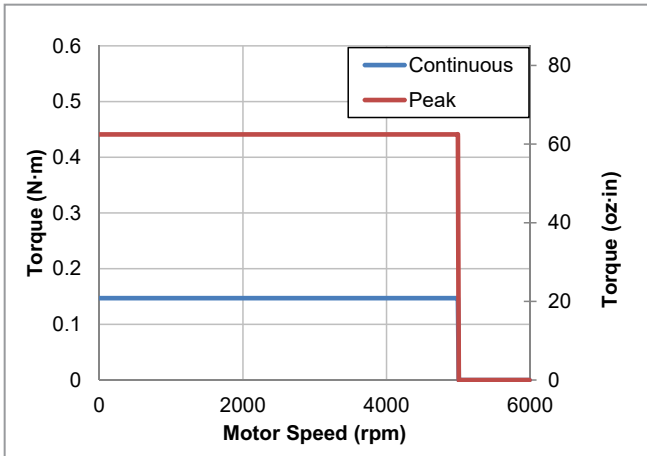

BM22 Torque vs. Speed

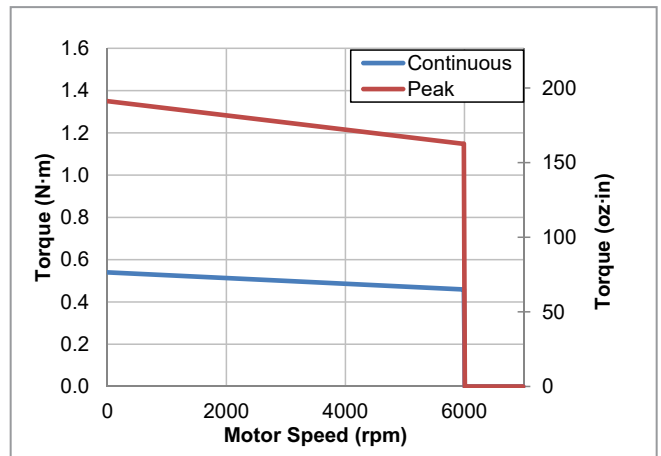

BM75 Torque vs. Speed

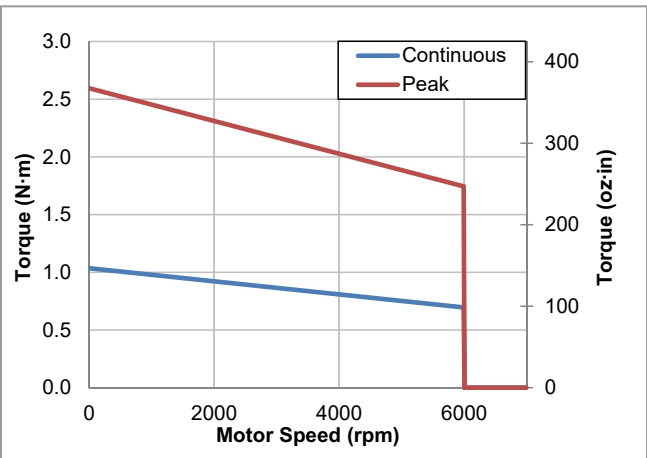

BM130 Torque vs. Speed

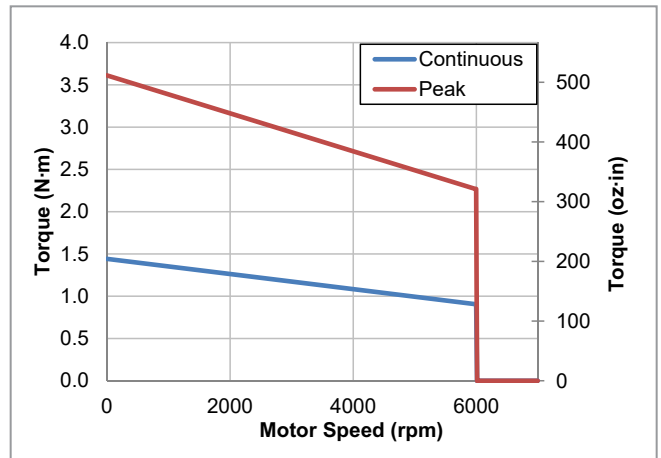

BM200 Torque vs. Speed

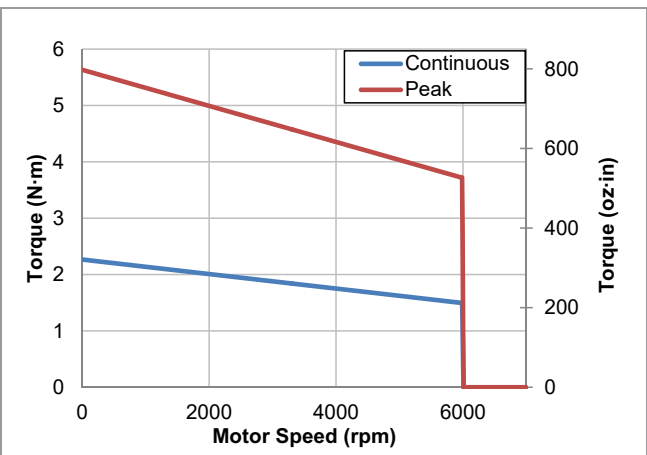

BM250 Torque vs. Speed

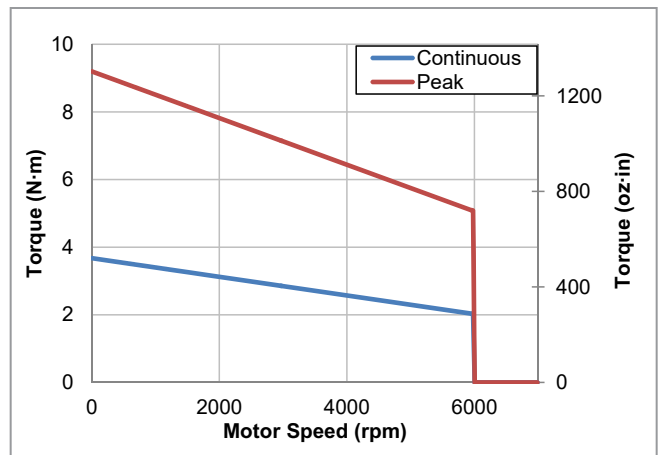

BM500 Torque vs. Speed

BM SERIES SPECIFICATIONS

BM SERIES MOTOR PERFORMANCE

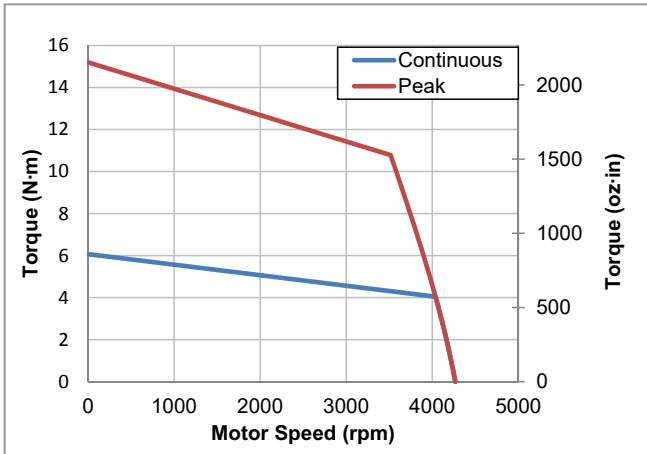

BM800 Torque vs. Speed

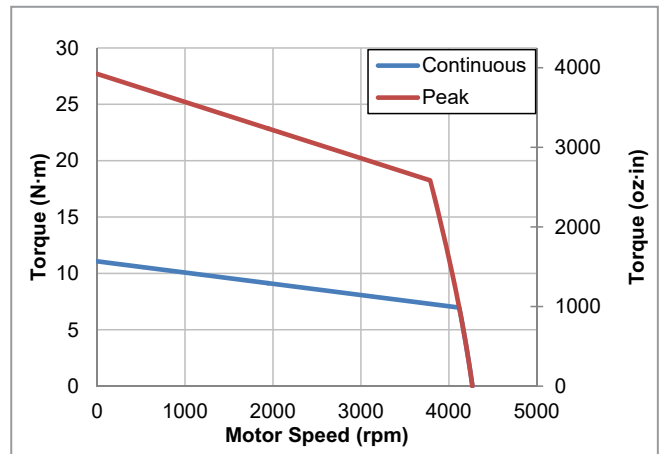

BM1400 Torque vs. Speed

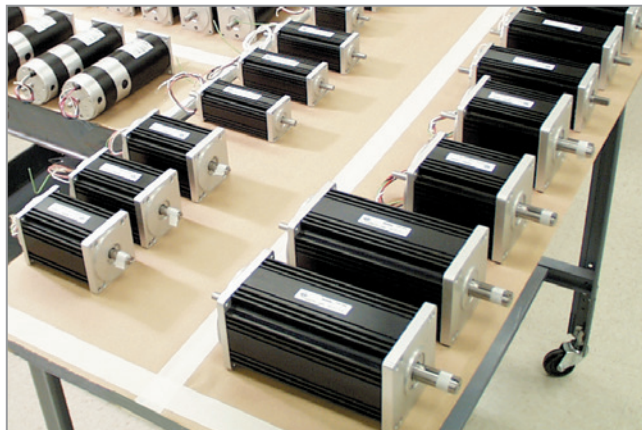

All Aerotech motors are manufactured following ISO9001 standards.

BM SERIES DIMENSIONS

NEMA 17 (BM22)

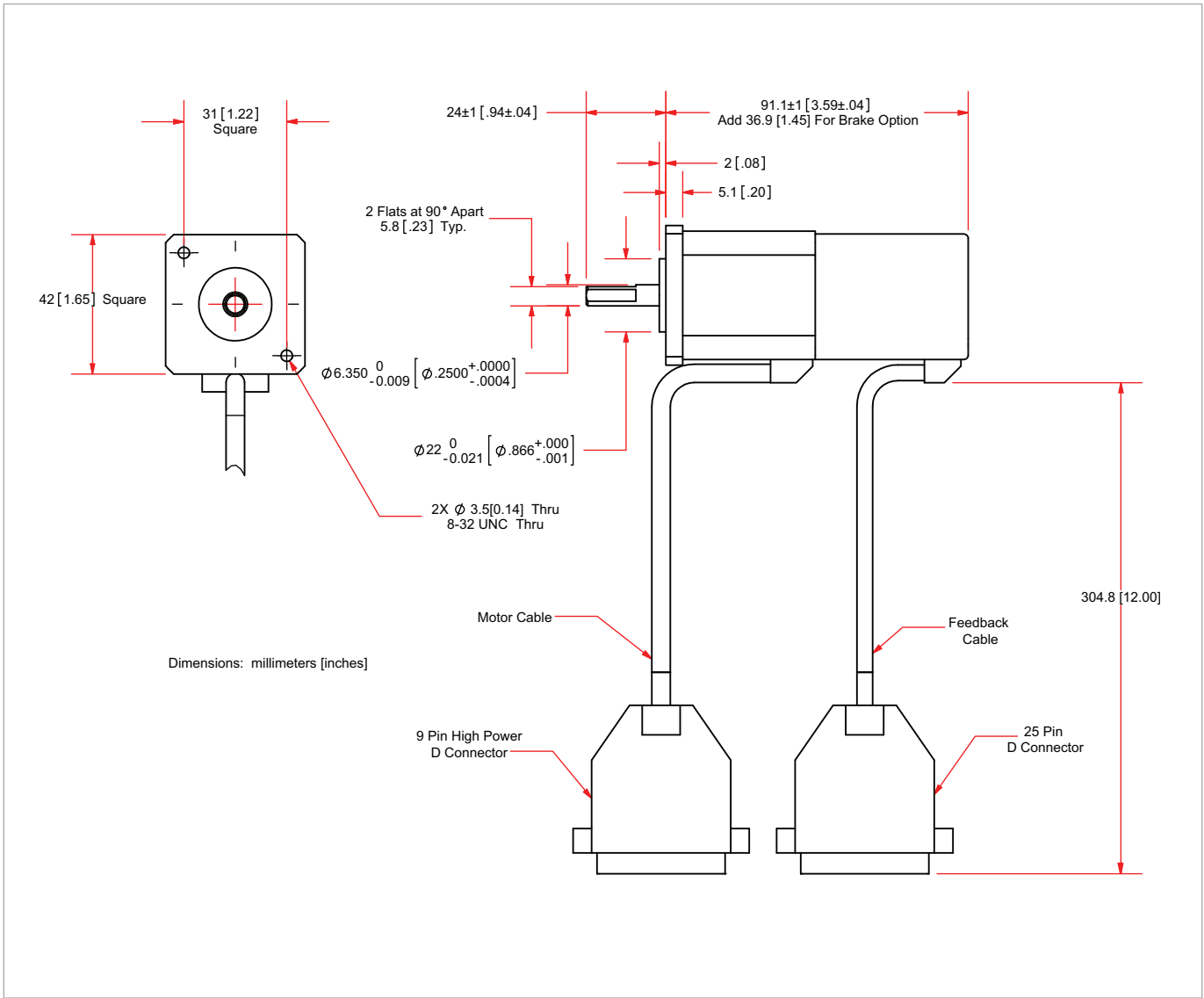

BM SERIES DIMENSIONS

NEMA 23 (BM75, BM130, BM200)

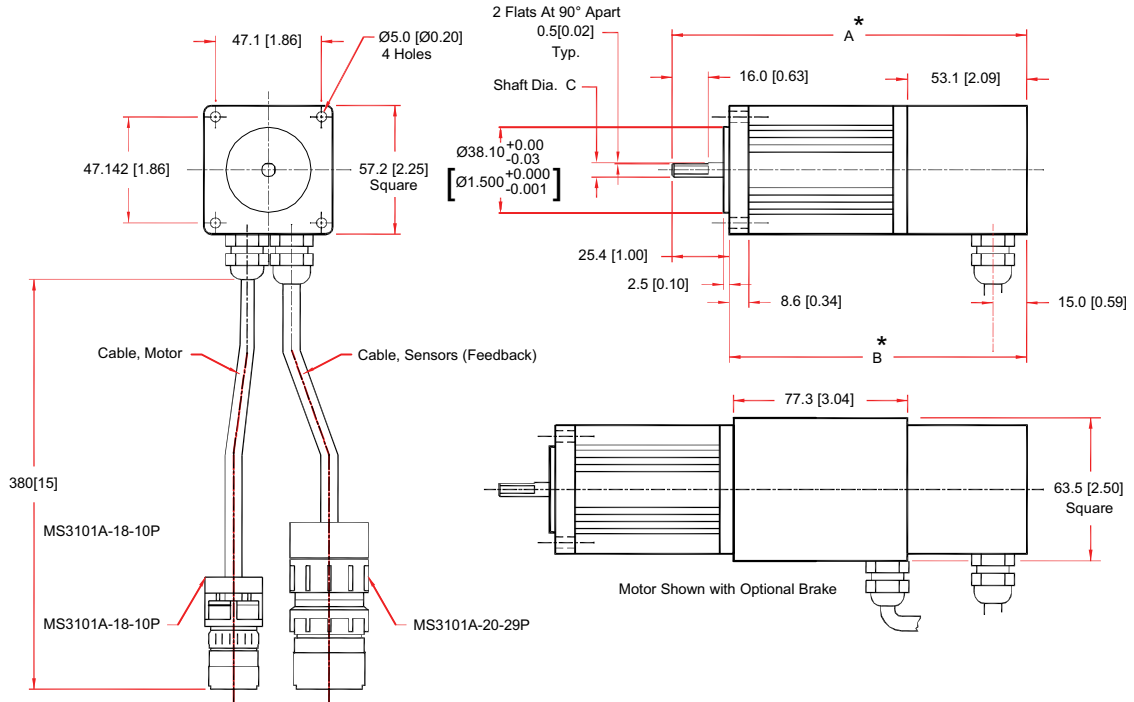

Dimensions - millimeters [inches]

Motor Model No.	A*	B*	C
BM75	$\frac{157.5}{6.20}$	$\frac{132.1}{5.20}$	$\varnothing 6.345$ $+0.000, -0.013$ 0.2498 $+0.0000", -0.0005"$
BM130	$\frac{187.9}{7.40}$	$\frac{162.6}{6.40}$	$\varnothing 9.517$ $+0.000, -0.013$ 0.3747 $+0.0000", -0.0005"$
BM200	$\frac{218.4}{8.60}$	$\frac{193.0}{7.60}$	$\varnothing 9.517$ $+0.000, -0.013$ 0.3747 $+0.0000", -0.0005"$

* Add 77.3 [3.04 IN.] To Length For Optional Brake.

BM SERIES DIMENSIONS

NEMA 34 (BM250, BM500)

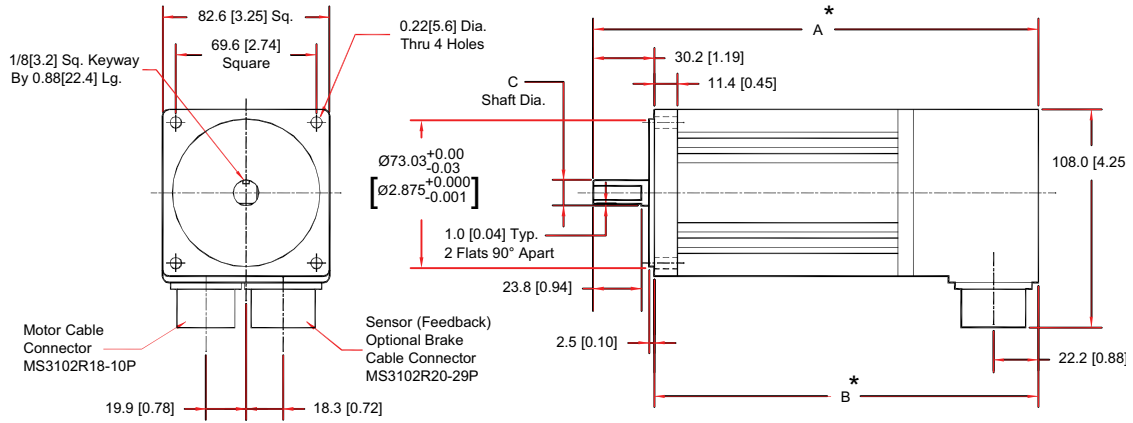

Dimensions - millimeters [inches]

Motor Model No.	A*	B*	C
BM250	220.3 8.67"	190.0 7.48"	Ø 12.69 +0.000, -0.013 0.4997" +0.0000", -0.0005"
BM500	275.1 10.83"	244.9 9.64"	Ø 12.69 +0.000, -0.013 0.4997" +0.0000", -0.0005"

* Add 55.6[2.19 IN.] To Length For Optional Brake.

NEMA 42 (BM800, BM1400)

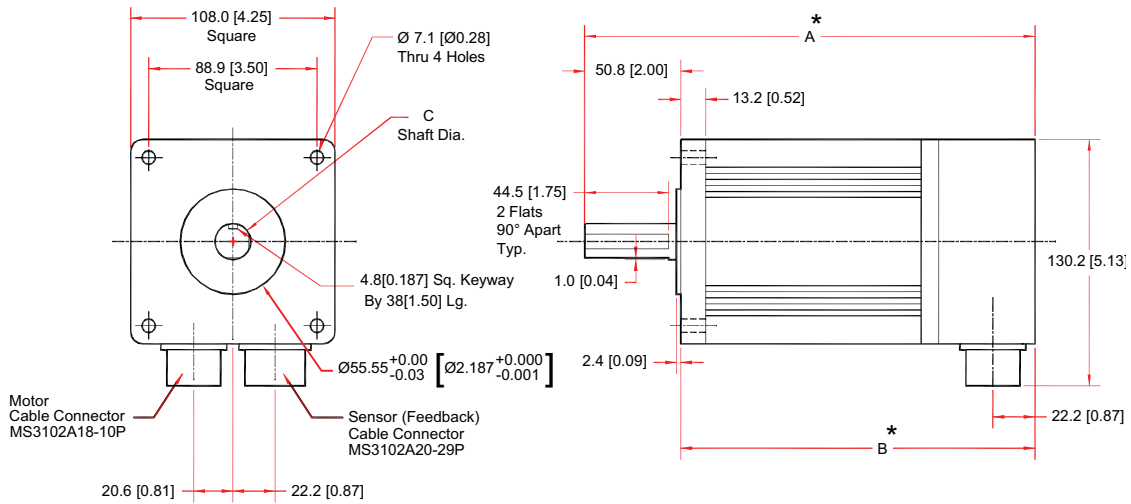

Dimensions - millimeters [inches]

Motor Model No.	A*	B*	C
BM800	238 9.37"	187 7.37"	Ø 19.04 +0.000, -0.013 0.7497" +0.0000", -0.0005"
BM1400	318 12.52"	267.2 10.52"	Ø 19.04 +0.000, -0.013 0.7497" +0.0000", -0.0005"

* Add 68.9[2.71 IN.] To Length For Optional Brake.