

AEROTECH



Brushless, Slotless
Rotary Motors

BMS Series

Smooth, Reliable Motion with Outstanding Velocity Control

Unlike conventional servomotors, the BMS series offers exceptionally smooth velocity control with its slotless stator design.

Compared to DC brush-type motors, BMS motors provide higher torque and acceleration, resulting in higher machine throughput and performance. Plus, BMS motors are more reliable because they have no brushes to wear.

Choose from our wide range of standard configurations or customize a BMS motor to meet your unique application requirements.

KEY FEATURES:

- ◆ **ELIMINATES COGGING** with slotless stator design
- ◆ **INCREASES RELIABILITY** with brushless technology
- ◆ Achieves **ULTRA-HIGH RESOLUTION** with amplified sine-wave encoder
- ◆ Available in standard **NEMA FRAME SIZES**
- ◆ Follows the **2011/65/EU ROHS 2** directive

BMS SERIES SPECIFICATIONS

Model	Units	BMS35	BMS60	BMS100	BMS280	BMS465
Winding Designation		-A				
Performance Specifications^{1,2}						
Stall Torque, Continuous ³	N·m	0.27	0.33	0.56	1.60	2.86
Peak Torque ⁴	N·m	1.07	1.31	2.26	6.41	11.43
Rated Speed	rpm	4000	4000	3000	3000	2000
Rated Power Output, Continuous	W	96.0	116.1	133	381	457
Electrical Specifications²						
BEMF Constant (Line-Line, Max)	$V_{pk}/krpm$	12.9	19.0	40.0	57.0	79.0
Continuous Current, Stall ³	A_{pk}	2.5	2.3	2.1	3.8	4.9
	A_{rms}	1.7	1.6	1.5	2.7	3.5
Peak Current, Stall ⁴	A_{pk}	9.8	9.2	8.4	15.2	19.6
	A_{rms}	6.9	6.5	5.9	10.7	13.9
Torque Constant ^{5,6}	$N·m/A_{pk}$	0.11	0.14	0.27	0.42	0.58
	$N·m/A_{rms}$	0.15	0.20	0.38	0.60	0.82
Motor Constant ^{3,5}	$N·m/\sqrt{W}$	0.046	0.050	0.076	0.179	0.280
Resistance, 25°C, (Line-Line)	Ω	5.8	8.4	12.9	5.7	4.4
Inductance (Line-Line)	mH	1.70	1.30	2.40	1.10	0.87
Maximum Bus Voltage	VDC	340				
Thermal Resistance	°C/W	2.21	1.73	1.35	0.93	0.72
Number of Poles	P	8			14	
Mechanical Specifications						
Frame Size	NEMA	17	23		34	
Mass	kg	0.6	1.1	1.5	3.6	5.0
Mass with Brake	kg	0.8	1.6	2.0	4.2	5.7
Rotor Moment of Inertia	$kg·m^2$	1.86×10^{-5}	1.96×10^{-5}	3.71×10^{-5}	4.33×10^{-4}	8.57×10^{-4}
Max. Radial Load	N	45	89		178	
Max. Axial Load	N	45	89			
Standards		2011/65/EU RoHS 2 Directive				

1. Performance is dependent upon heat sink configuration, system cooling conditions, and ambient temperature.

2. All performance and electrical specifications $\pm 10\%$.

3. Values shown @75°C rise above a 25°C ambient temperature, with housed motor mounted to a 250 mm x 250 mm x 6 mm aluminum heat sink.

4. Peak torque assumes correct rms current; consult Aerotech.

5. Torque constant and motor constant specified at stall.

6. All Aerotech amplifiers are rated A_{pk} ; use torque constant in $N·m/A_{pk}$ when sizing.

BMS SERIES ORDERING INFORMATION

NEMA Brushless Slotless Rotary Servomotor

BMS35	NEMA17 brushless slotless rotary servomotor
BMS60	NEMA23 brushless slotless rotary servomotor
BMS100	NEMA23 brushless slotless rotary servomotor
BMS280	NEMA34 brushless slotless rotary servomotor
BMS465	NEMA34 brushless slotless rotary servomotor

Motor Winding (Required)

-A	Motor winding
-B	Motor winding; not available for BMS35

Connectors (Required)

-MS	Integral cable w/MS connector for Fbk and Mtr; not available for BMS35
-D25	Integral cable w/D25 Fbk and 4D Mtr; not available for BMS280 or BMS465
-D25-9D	Integral cable w/D25 Fbk, 4D Mtr, and 9D Limit; not available for BMS280 or BMS465
-D25-FLB	Integral cable w/D25 Fbk, Fly Leads for Mtr, and 9D Limit; not available for BMS280 or BMS465
-D25-5DU	Integral cable w/D25 Fbk, 5D Mtr, and 9D Limit; not available for BMS280 or BMS465
-D25-9D-CMS	Integral cable w/D25 Fbk, 4D Mtr, and 9D Limit - CMS only; not available for BMS280 or BMS465
-D25-4TS	Integral cable w/D25 Fbk, 4TS Mtr, and 9D Limit; not available for BMS280 or BMS465

Feedback (Required)

-E1000H	1000 lines/rev TTL incremental encoder w/Hall tracks
-E2000H	2000 lines/rev TTL incremental encoder w/Hall tracks
-E2500H	2500 lines/rev TTL incremental encoder w/Hall tracks; not available for BMS35
-E5000H	5000 lines/rev TTL incremental encoder w/Hall tracks
-E1000ASH	1000 lines/rev 1 Vpp incremental encoder w/Hall tracks

Brake (Optional)

-BK	Holding brake
------------	---------------

Cable Type (Optional)

-HF	High flex cable; not available for BMS280 or BMS465
------------	---

Cable Length (dm; Optional)

-xx	Cable length in decimeters (3.8 dm is default)
------------	--

Note: Not available for BMS280 or BMS465.

Vacuum Preparation (Optional)

-VAC6	Vacuum preparation to 10 ⁻⁶ Torr
--------------	---

Accessories (Optional)

MC-HPD25-M	Connector; HPD motor power mate
MC-DB25-F	Connector; DB25 motor feedback mate
MCM-3	Connector; MS motor power mate
MCF-3	Connector; MS motor feedback mate

Note: Accessories are ordered as separate line items.

BMS SERIES SPECIFICATIONS

BMS SERIES MOTOR PERFORMANCE

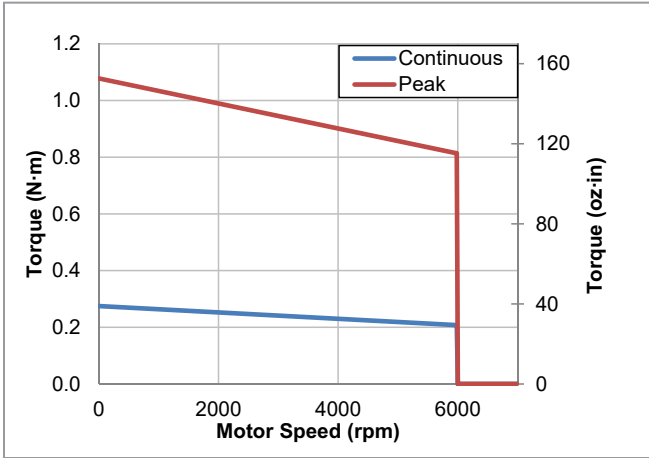

BMS35 Torque vs. Speed

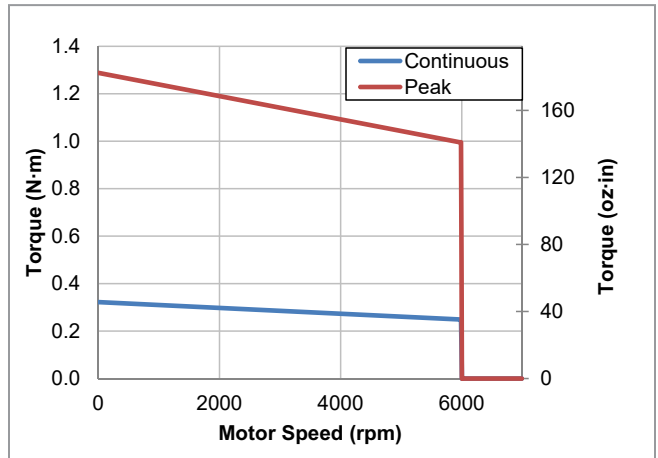

BMS60 Torque vs. Speed

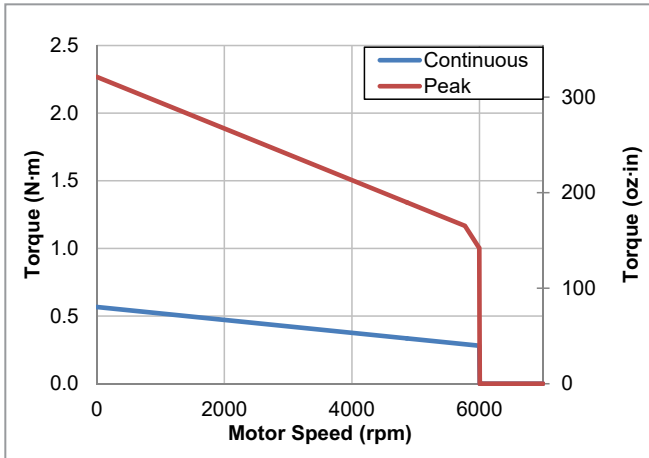

BMS100 Torque vs. Speed

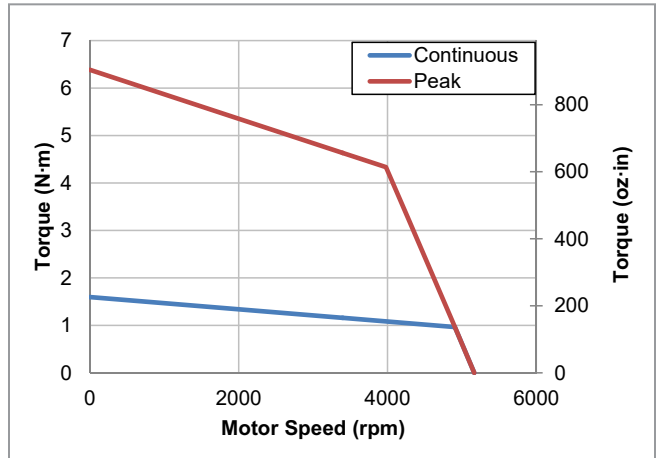

BMS280 Torque vs. Speed

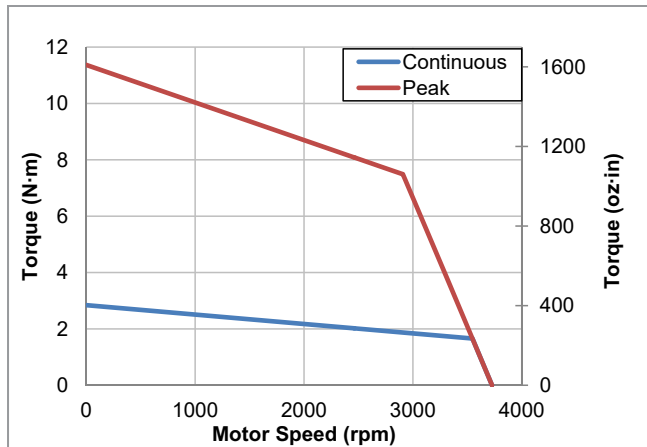

BMS465 Torque vs. Speed

BMS SERIES DIMENSIONS

NEMA 17 (BMS35)

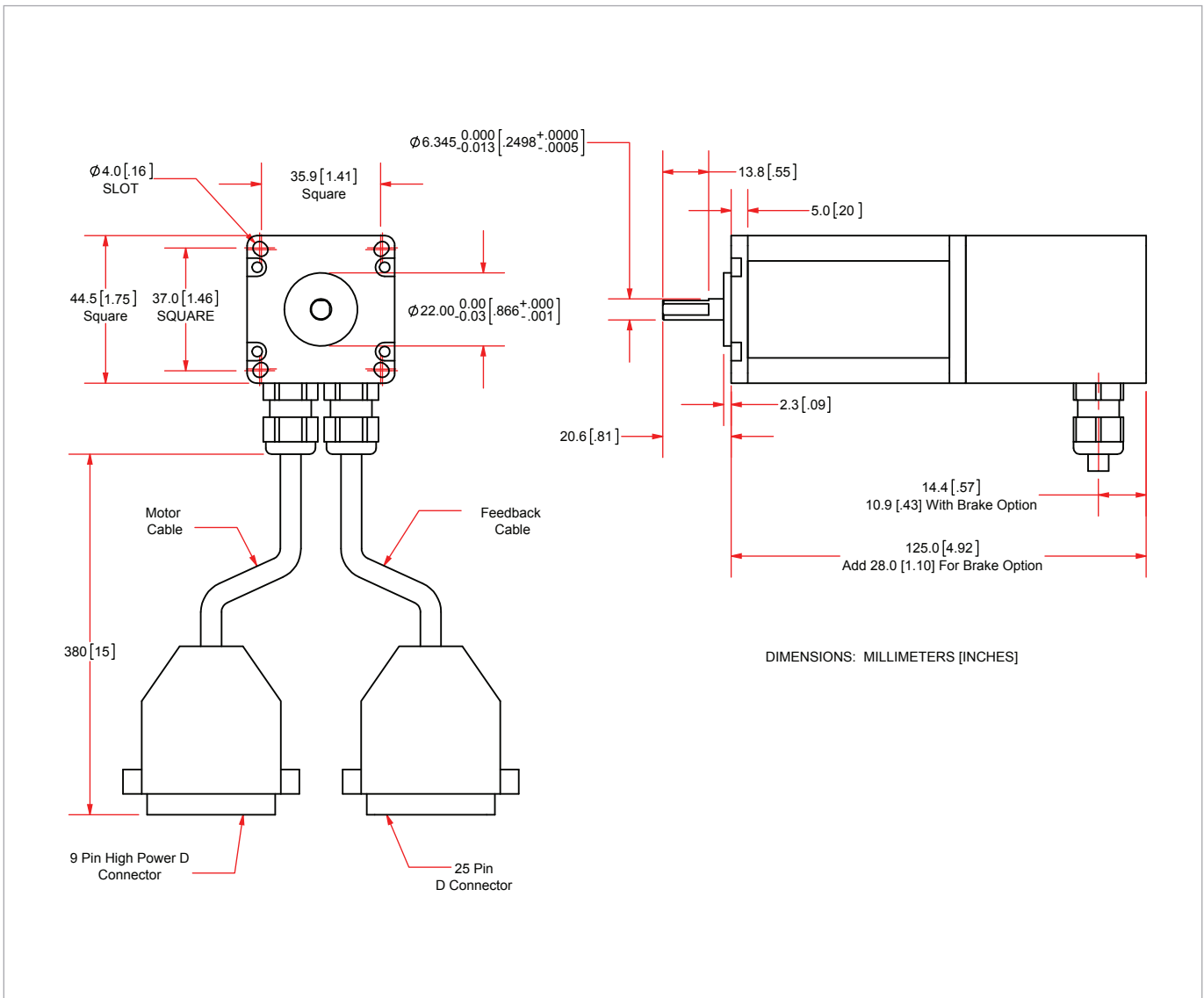

BMS SERIES DIMENSIONS

NEMA 23 (BMS60, BMS100)

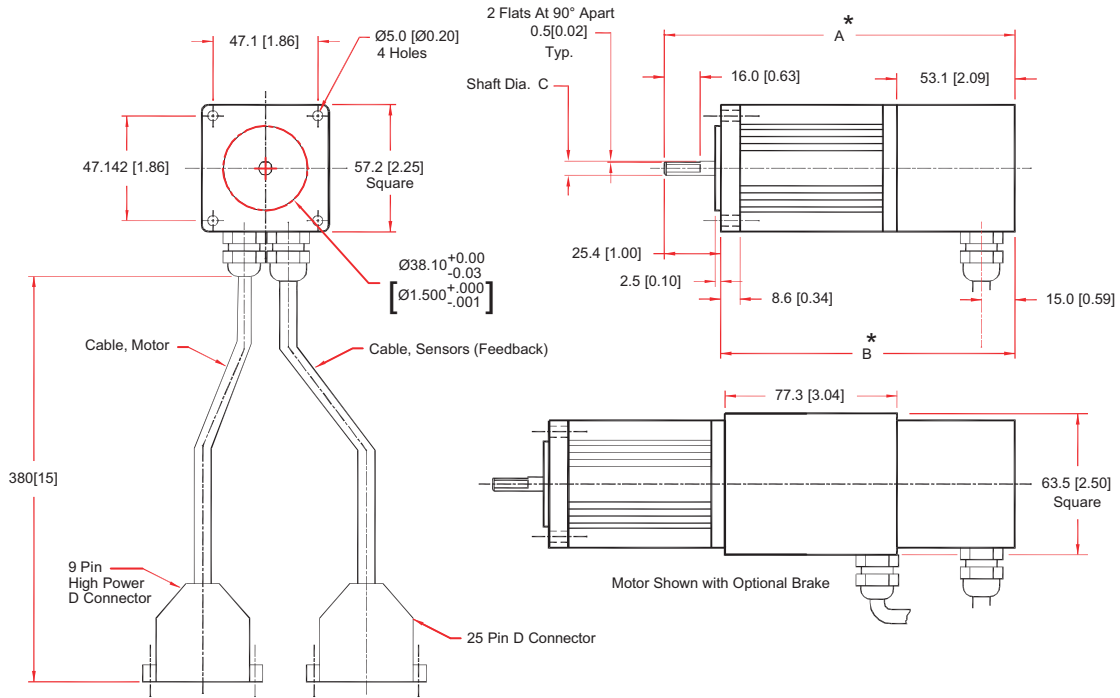

Dimensions - millimeters [inches]

Motor Model No.	A *	B *	C
BMS60	$\frac{157.5}{6.20''}$	$\frac{132.1}{5.20''}$	$\frac{\text{Ø } 6.345}{0.2498''}$ +0.000, -0.013 +0.0000", -0.0005"
BMS100	$\frac{187.9}{7.40''}$	$\frac{162.6}{6.40''}$	$\frac{\text{Ø } 9.517}{0.3747''}$ +0.000, -0.013 +0.0000", -0.0005"

* Add 77.3 [3.04 IN.] To Length For Optional Brake.

BMS SERIES DIMENSIONS

NEMA 34 (BMS280, BMS465)

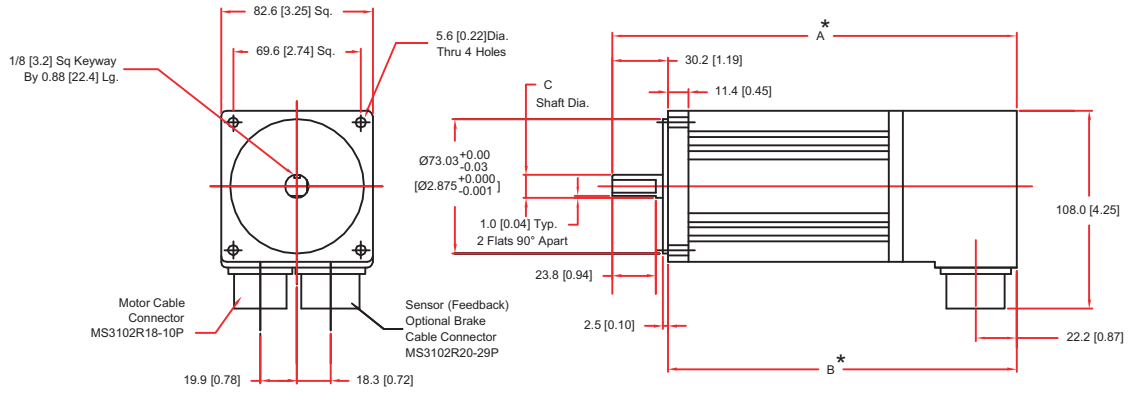

Dimensions - millimeters [inches]

Motor Model No.	A *	B *	C
BMS280	$\frac{220.3}{8.67"} \pm 0.005$	$\frac{190.0}{7.48"} \pm 0.005$	$\frac{\varnothing 12.69}{0.4997"} \begin{matrix} +0.000, -0.013 \\ +0.0000", -0.0005" \end{matrix}$
BMS465	$\frac{275.1}{10.83"} \pm 0.005$	$\frac{244.9}{9.64"} \pm 0.005$	$\frac{\varnothing 12.69}{0.4997"} \begin{matrix} +0.000, -0.013 \\ +0.0000", -0.0005" \end{matrix}$

* Add 55.6[2.19 IN.] To Length For Optional Brake.