

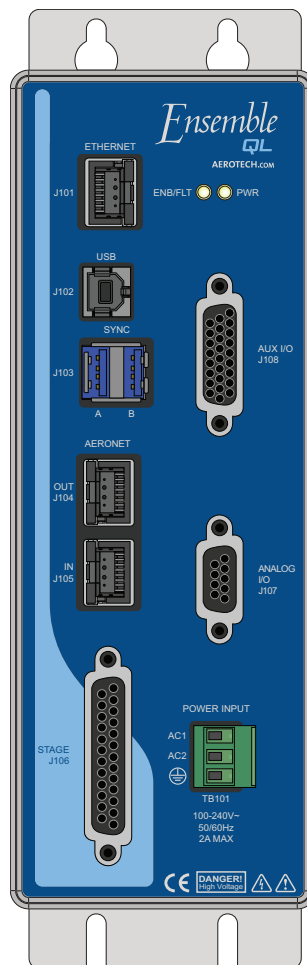

Ensemble QL Hardware Manual

Revision: 1.03.00



Global Technical Support

Go to www.aerotech.com/global-technical-support for information and support about your Aerotech products. The website provides downloadable resources (such as up-to-date software, product manuals, and Help files), training schedules, and PC-to-PC remote technical support. You can also complete Product Return (RMA) forms and get information about repairs and spare or replacement parts. For immediate help, contact a service office or your sales representative. Have your customer order number available before you call or include it in your email.

United States (World Headquarters)	
Phone: +1-412-967-6440 Fax: +1-412-967-6870 Email: service@aerotech.com	101 Zeta Drive Pittsburgh, PA 15238-2811 www.aerotech.com
United Kingdom	Japan
Phone: +44 (0)1256 855055 Fax: +44 (0)1256 855649 Email: service@aerotech.co.uk	Phone: +81 (0)50 5830 6814 Fax: +81 (0)43 306 3773 Email: service@aerotechkk.co.jp
Germany	China
Phone: +49 (0)911 967 9370 Fax: +49 (0)911 967 93720 Email: service@aerotechgmbh.de	Phone: +86 (21) 3319 7715 Email: service@aerotech.com
France	Taiwan
Phone: +33 2 37 21 87 65 Email: service@aerotech.co.uk	Phone: +886 (0)2 8751 6690 Email: service@aerotech.tw

This manual contains proprietary information and may not be reproduced, disclosed, or used in whole or in part without the express written permission of Aerotech, Inc. Product names mentioned herein are used for identification purposes only and may be trademarks of their respective companies.

Copyright © 2015-2018, Aerotech, Inc., All rights reserved.

Aerotech Worldwide

United States ■ France ■ Germany ■ United Kingdom
China ■ Japan ■ Taiwan



Table of Contents

- Ensemble QL Hardware Manual** **1**
 - Table of Contents 3
 - List of Figures 4
 - List of Tables 5
 - EU Declaration of Conformity 7
 - Agency Approvals 8
 - Safety Procedures and Warnings 9
 - Quick Installation Guide 11

- Chapter 1: Introduction** **13**
 - 1.1. Electrical Specifications 16
 - 1.2. Mechanical Design 17
 - 1.3. Environmental Specifications 18

- Chapter 2: Installation and Configuration** **19**
 - 2.1. Unpacking the Chassis 19
 - 2.2. Electrical Installation 20
 - 2.2.1. Power Input (TB101) 20
 - 2.2.2. I/O and Signal Wiring Requirements 21
 - 2.3. Stage Power and Feedback Connections (J106) 22
 - 2.4. Auxiliary I/O Connector (J108) 24
 - 2.4.1. Position Synchronized Output (PSO) 25
 - 2.4.2. Opto-Isolated Outputs 0-3 27
 - 2.4.3. Opto-Isolated Inputs 0-3 29
 - 2.4.4. High-Speed User Inputs 4-5 31
 - 2.4.5. Analog Output 0 32
 - 2.4.6. Differential Analog Input 0 33
 - 2.5. Analog I/O Connector (J107) 34
 - 2.5.1. Voltage Monitor Output 35
 - 2.5.2. External Voltage Command 36
 - 2.6. Communication 37
 - 2.6.1. USB Interface 37
 - 2.6.2. Ethernet Interface 38
 - 2.6.3. Aeronet Interface 39
 - 2.6.4. SYNC Interface 40
 - 2.7. PC Configuration and Operation Information 41

- Chapter 3: Maintenance** **43**
 - 3.1. Preventative Maintenance 44

- Appendix A: Warranty and Field Service** **45**

- Appendix B: Revision History** **47**

- Index** **49**

List of Figures

Figure 1-1: Functional Diagram15

Figure 1-2: Dimensions17

Figure 2-1: Power Input Connections20

Figure 2-2: Connection to Third Party Stage23

Figure 2-3: PSO Interface26

Figure 2-4: Outputs Connected in Current Sourcing Mode (J108)28

Figure 2-5: Outputs Connected in Current Sinking Mode (J108)28

Figure 2-6: Inputs Connected in Current Sourcing Mode (J108)30

Figure 2-7: Inputs Connected in Current Sinking Mode (J108)30

Figure 2-8: High Speed User Inputs (J108)31

Figure 2-9: Analog Input 0 (J108)33

Figure 2-10: USB Connection Location37

Figure 2-11: Ethernet Connection Location38

Figure 2-12: Aeronet Connections39

Figure 2-13: Sync Interface40

List of Tables

Table 1-1:	Configuration and Options	14
Table 1-2:	Electrical Specifications	16
Table 1-3:	Physical Specifications	17
Table 2-1:	Power Supply Wiring (TB101)	20
Table 2-2:	I/O and Signal Wiring Specifications	21
Table 2-3:	Power and Feedback Connector (J106)	22
Table 2-4:	Auxiliary I/O Interface Pin Assignment (J108)	24
Table 2-5:	PSO Specifications	25
Table 2-6:	PSO Output Pin Assignment (J108)	25
Table 2-7:	Digital Output Specifications	27
Table 2-8:	Digital Output Connector Pin Assignment (J108)	27
Table 2-9:	PS2815-4 Opto-Device Specifications	29
Table 2-10:	Digital Input Connector Pin Assignment (J108)	29
Table 2-11:	High Speed Digital Input Connector Pin Assignment (J108)	31
Table 2-12:	High-Speed Digital Input Specifications	31
Table 2-13:	Analog Output Specifications (J108)	32
Table 2-14:	Analog Output 0 Connector Pin Assignment (J108)	32
Table 2-15:	Differential Analog Input Specifications (J108)	33
Table 2-16:	Analog Input Connector Pin Assignment (J108)	33
Table 2-17:	Analog I/O Connector Pin Assignment (J107)	34
Table 2-18:	Voltage Monitor Output Connector Pin Assignment (J107)	35
Table 2-19:	Voltage Monitor Output Scaling	35
Table 2-20:	Voltage Monitor Output Specifications	35
Table 2-21:	External Voltage Command Connector Pin Assignment (J107)	36
Table 2-22:	External Voltage Command Scaling	36
Table 2-23:	External Voltage Command Specifications	36
Table 2-24:	Aeronet Cable Part Numbers	39
Table 3-1:	LED Description	43
Table 3-2:	Troubleshooting	43
Table 3-3:	Preventative Maintenance	44

This page intentionally left blank.

EU Declaration of Conformity

Manufacturer Aerotech, Inc.
Address 101 Zeta Drive
 Pittsburgh, PA 15238-2811
 USA
Product Ensemble QL
Model/Types All

This is to certify that the aforementioned product is in accordance with the applicable requirements of the following Directive(s):

2014/35/EU	Low Voltage Directive LVD
2011/65/EU	RoHS 2 Directive

and has been designed to be in conformity with the applicable requirements of the following documents when installed and used in accordance with the manufacturer’s supplied installation instructions.

EN 61010-1:2010	Safety requirements for electrical equipment
-----------------	--

Authorized Representative: Simon Smith, European Director
Address: Aerotech Ltd
 The Old Brick Kiln
 Ramsdell, Tadley
 Hampshire RG26 5PR
 UK

Name  / Alex Weibel
Position Engineer Verifying Compliance
Location Pittsburgh, PA



Agency Approvals

Aerotech, Inc. Model Ensemble QL Drives have been tested and found to be in accordance to the following listed Agency Approvals:

Approval / Certification:	CUS NRTL
Approving Agency:	TUV SUD America Inc.
Certificate #:	U8 16 06 68995 019
Standards:	UL 61010-1:2012; CAN/CSA-C22.2 No. 61010-1:2012; EN 61010-1:2010

Safety Procedures and Warnings

The following statements apply wherever the Warning or Danger symbol appears within this manual. Failure to observe these precautions could result in serious injury to those individuals performing the procedures and/or damage to the equipment.

**WARNING:**

To minimize the possibility of electrical shock, bodily injury or death the following precautions must be followed.

1. Operators must be trained before allowing them to operate the equipment.
2. All service and maintenance must be performed by qualified personnel.
3. Modification or use of this product in an unspecified manner may result in equipment damage or bodily injury (shock or death).
4. The user must read this manual and related documentation thoroughly before operating the equipment.
5. Cables can pose a tripping hazard. Securely mount and position all system cables to avoid potential hazards.
6. This product must be mounted securely. Improper mounting can result in injury and damage to the equipment.

**DANGER:**

This product contains potentially lethal voltages. To reduce the possibility of electrical shock, bodily injury or death the following precautions must be followed.

1. Do not connect or disconnect any electrical components or connecting cables while connected to a power source.
2. Disconnect electrical power before making any mechanical adjustments or performing maintenance.
3. Do not remove the stage connection (J106) while the controller is engaged. Always remove AC mains power before making a connection to the controller.
4. To avoid the risk of electric shock, do not touch the piezo stage while it is energized.
5. Make sure the system is properly grounded in accordance with local electrical safety requirements.
6. Operator safeguarding requirements must be addressed during final integration of the product.

This page intentionally left blank.

Quick Installation Guide

This chapter describes the order in which connections and settings should typically be made to the Ensemble QL. If a custom interconnection drawing was created for your system (look for a line item on your Sales Order under the heading “Integration”), that drawing can be found on your Software or Documentation DVD.

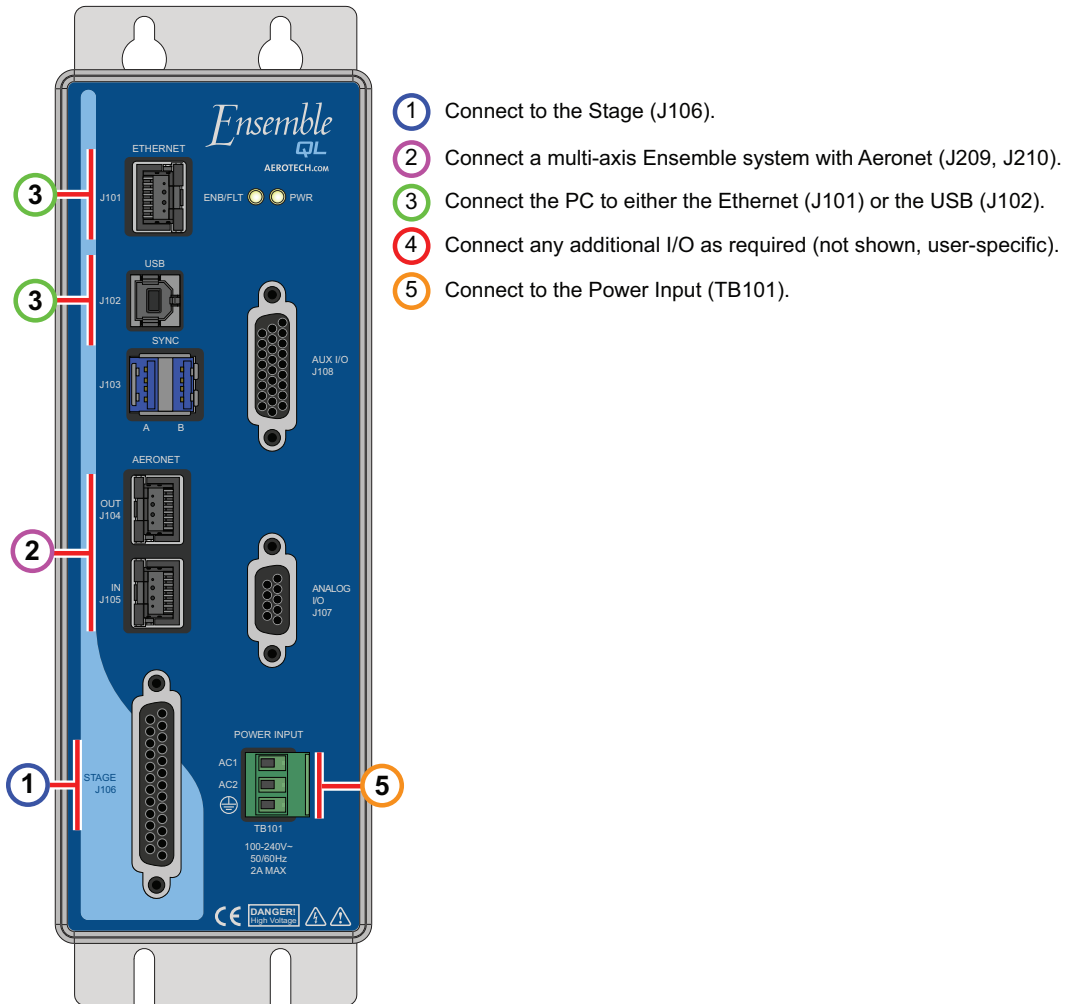

Figure 1: Quick Start Connections

Topic	Section
Connect to J106	Refer to Section 2.3 .
Connect the Aeronet	Refer to Section 2.6.3 .
Connect to TB101	Refer to Section 2.2.1 .
Connect to J107	Refer to Section 2.5 .
Connect to J108	Refer to Section 2.4 .

This page intentionally left blank.

Chapter 1: Introduction

The Ensemble QL is a panel-mount nanopositioning piezo drive that connects to any Ensemble controller network enabling a high rate of coordinated motion between piezo stages and servo axes.

QL drives feature a dual-core 456 MHz, double-precision, floating-point DSP that provides extreme processing power over a wide variety of applications including point-to-point motion, linear and circular interpolation, multi-axis error correction, and auto-focusing. High-speed interrupts and data logging capabilities provide a real-time link to external systems. The QL also offers high-speed positioning latching capability and single-axis position synchronized output (PSO) for generation of pulses based on actual position feedback in applications ranging from laser firing to data acquisition system triggering.

<p>A</p>	<p>ENB/FLT (Enable/Fault) Indicator PWR (Power) Indicator</p>	<p>The diagram shows the front panel of the Ensemble QL drive. It features several connectors and indicators: <ul style="list-style-type: none"> A: ENB/FLT (Enable/Fault) and PWR (Power) indicators. B: AUX I/O (J108) connector. C: ANALOG I/O (J107) connector. D: POWER INPUT (TB101) terminal block. E: ETHERNET (J101) connector. F: USB (J102) connector. G: SYNC (J103) connector. H: AERONET OUT (J104) and IN (J105) connectors. I: STAGE (J106) connector. </p>
<p>B</p>	<p>AUX I/O (J108) Connector</p>	
<p>C</p>	<p>ANALOG I/O (J107) Connector</p>	
<p>D</p>	<p>POWER INPUT (TB101)</p>	
<p>E</p>	<p>ETHERNET (J101)</p>	
<p>F</p>	<p>USB (J102)</p>	
<p>G</p>	<p>SYNC (J103)</p>	
<p>H</p>	<p>AERONET OUT: J104 IN: J105</p>	
<p>I</p>	<p>STAGE (J106) Connector</p>	

Table 1-1: Configuration and Options

Ensemble QL	
Ensemble QL250-C	Cost-effective networkable, standalone panel-mount piezo drive with capacitive sensor feedback, 250 mA peak current, 50 mA continuous current, -30 to +150 V output.
Ensemble QL500-C	Cost-effective networkable, standalone panel-mount piezo drive with capacitive sensor feedback, 500 mA peak current, 175 mA continuous current, -30 to +150 V output.
Features	
	<ul style="list-style-type: none"> • Configurable input/outputs; 4 opto-isolated inputs, two high-speed digital inputs, 4 opto-isolated outputs, one 16-bit analog input, and one 16-bit analog output • Single-axis Position Synchronized Output (PSO) standard • 10/100 base T Ethernet port; 1 USB 2.0 port • Motion Designer software is used to graphically generate and edit motion profiles that execute on the controller, providing the ability to import, run and evaluate motion profiles (trajectories). Included in the Motion Designer software is learning control that reduces tracking errors by as much as 1000 times
Software Options	
-DYNAMIC CONTROLS TOOLBOX	The Dynamic Controls Toolbox provides control algorithms that increase system performance such as settle time, accuracy, in-position stability and/or velocity stability.
-LABVIEW	LabVIEW® VI samples
-MATLAB	Includes MATLAB® library for motion, parameters, and data collection.

The following block diagram shows a connection summary (refer to Chapter 2 and Chapter 3 for more detailed connection information).

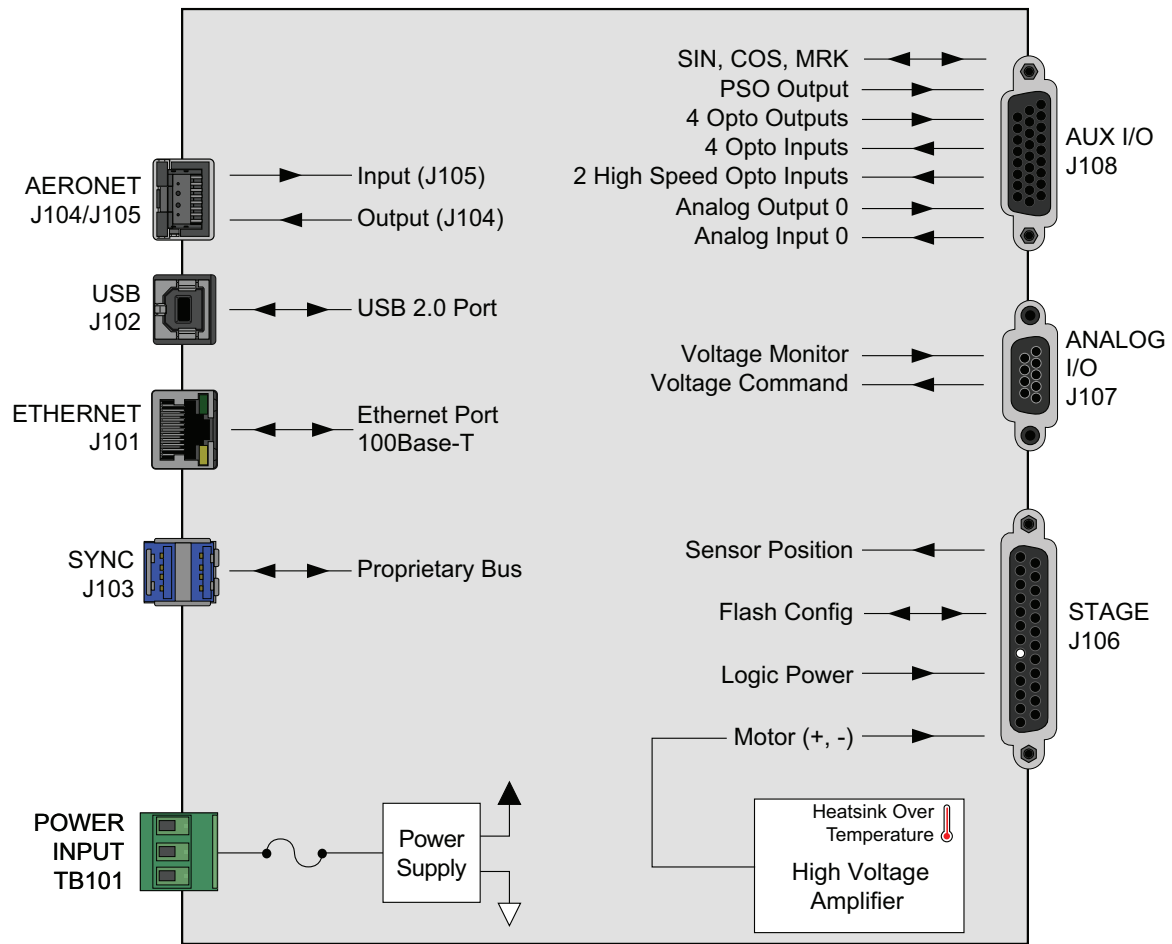

Figure 1-1: Functional Diagram

1.1. Electrical Specifications

The electrical specifications for the Ensemble QL are listed below.

Table 1-2: Electrical Specifications

Description		Ensemble QL250-C	Ensemble QL500-C
Power Supply	Input Voltage [Nominal Range]	100-240 VAC (auto-ranging)	100-240 VAC (auto-ranging)
	Input Voltage [Maximum Range]	85-264 VAC (auto-ranging)	85-264 VAC (auto-ranging)
	Input Frequency	47-63 Hz	47-63 Hz
	Peak Inrush Current	25 A / 115 VAC; 50 A / 230 VAC	25 A / 115 VAC; 50 A / 230 VAC
	Input Power	75 W	75 W
Piezo Actuator Output Voltage		-30 to +150 V	-30 to +150 V
Peak Output Current		250 mA	500 mA
Continuous Output Current		50 mA	175 mA
Warm Up Time		15 Minutes	15 Minutes
Sensor Resolution		17-Bit (closed-loop)	17-Bit (closed-loop)
Voltage Resolution		18-Bit (open-loop)	18-Bit (open-loop)
High-Speed Data Capture		50 ns latency	50 ns latency
Servo Loop Update		20 kHz	20 kHz

1.2. Mechanical Design

The following figure shows the Ensemble QL package dimension as well as the typical mounting orientation.

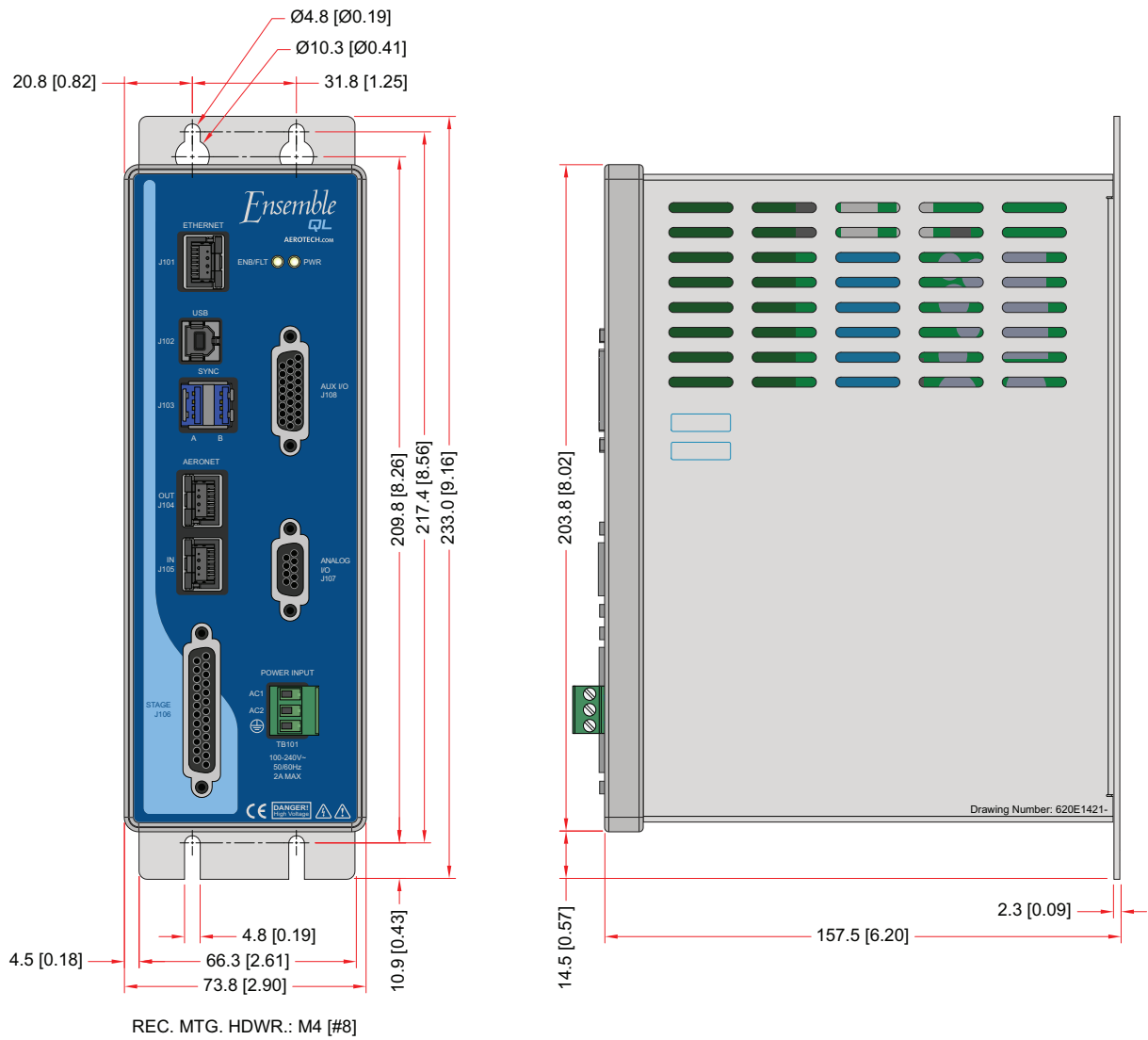

Figure 1-2: Dimensions

Table 1-3: Physical Specifications

Weight
1.3 kg [2.8 lbs]

1.3. Environmental Specifications

The environmental specifications for the Ensemble QL are listed below.

Ambient Temperature	Operating: 0° to 50°C (32° to 122° F)
	Storage: -30° to 85°C (-22° to 185° F)
Humidity	Maximum relative humidity is 80% for temperatures up to 31°C. Decreasing linearly to 50% relative humidity at 40°C. Non condensing.
Altitude	Up to 2000 meters.
Pollution	Pollution degree 2 (normally only non-conductive pollution).
Use	Indoor use only.

Chapter 2: Installation and Configuration

This section describes the minimum hardware installation and configuration requirements for the Ensemble QL. This installation will provide information on AC power connections and motor wiring.



DANGER: To minimize the possibility of bodily injury or death, disconnect all electrical power prior to performing any maintenance or making adjustments to the equipment.

2.1. Unpacking the Chassis



DANGER: All electronic equipment and instrumentation are wrapped in antistatic material and packaged with desiccant. Ensure that the antistatic material is not damaged during unpacking.

Visually inspect the container of the QL for any evidence of shipping damage. If any such damage exists, notify the shipping carrier immediately.

Remove the packing list from the QL container. Make sure that all the items specified on the packing list are contained within the package.

All of the documentation provided with the QL should be saved for future reference. Additional information about the QL system is provided on the Serial and Power labels that are placed on the QL chassis.

The system serial number label contains important information such as the:

- Customer order number (please provide this number when requesting product support)
- Drawing number
- System part number

2.2. Electrical Installation

The Ensemble QL has one AC input power connector. For a complete list of electrical specifications, refer to [Section 1.1. Electrical Specifications](#).

2.2.1. Power Input (TB101)

AC input power to the QL is applied to the Input Power (TB101) connector.

The connection requires a minimum of 100 VAC input to operate properly. The AC1 and AC2 inputs are internally fused. [Figure 2-1](#) shows the required connections to the control power input.

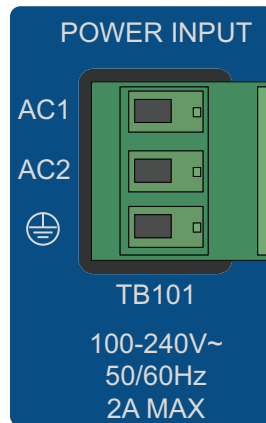



Figure 2-1: Power Input Connections

Table 2-1: Power Supply Wiring (TB101)

Pin	Description	Recommended Wire Size
AC1	100 - 240 VAC Input Range	1.3 mm ² (#16 AWG)
AC2	100 - 240 VAC Input Range	1.3 mm ² (#16 AWG)
	Protective Ground (Required for Safety)	1.3 mm ² (#16 AWG)

Type	Aerotech P/N	Phoenix P/N	Screw Torque Value: Nm	Wire Size: AWG [mm ²]
3-Pin Terminal Block	ECK00213	1754465	0.5 - 0.6	12-30 [3.3 - 0.516]

2.2.2. I/O and Signal Wiring Requirements

The I/O, communication, and encoder feedback connections are typically very low power connections. In some applications, especially when there are significant wire distances, a larger wire size may be required to reduce the voltage drop that occurs along the wire. This increase may be necessary in order to keep the voltage within a specified range at a remote point.

Low voltage and high voltage wires should be kept physically separated so that they cannot contact one another. This reduces the risk of electric shock and improves system performance.

Table 2-2: I/O and Signal Wiring Specifications

Connection	Specification	Value
Signal Wiring	Cable/Wire Rating ⁽¹⁾	300 V
	Minimum Current Capacity	.25 A
	Temperature Rating (Insulation) ⁽²⁾	80°C
Low Voltage Power	Cable/Wire Rating ⁽¹⁾	300 V
	Minimum Current Capacity ⁽³⁾	1 A
	Temperature Rating (Insulation) ⁽²⁾	80°C
1. ≥ 30 V if the wiring is not in close proximity to wiring operating at voltages above 60 V. 2. Insulation rating will need to be rated for the higher voltage if the wiring is in proximity to wiring operating at voltages above 60 V. 3. Larger gauge wire may be required to minimize voltage drop due to voltage (IR) loss in the cable.		

2.3. Stage Power and Feedback Connections (J106)



DANGER: HIGH VOLTAGE

1. Do not remove the stage connection (J106) while the controller is engaged. Always remove AC mains power before making a connection to the controller.
2. To avoid the risk of electric shock, do not touch the piezo stage while it is energized.

The capacitance sensor interface is designed to work with Aerotech stages and cannot be used with third party sensors. The position feedback input signal (Pin 22) has a range of -10 to 10 VDC and can be connected to a third-party sensor with DC output. The piezo actuator is connected between pins 13 and 25. Refer to [Section 1.1](#) for electrical specifications. The frame ground connection must be made when connecting third-party stages.

Table 2-3: Power and Feedback Connector (J106)

Pin	Description	In/Out/BI	Connector
CASE	Outer Shield	--	
8	Connector key (to prevent improper connection)	--	
12	Frame ground for piezo stage	--	
13	Piezo Actuator High Voltage Output + (-30 to 150V)	Output	
22	Position Feedback Input (± 10 VDC)	Input	
25	Piezo Actuator Return -	Output	
1	Reserved	--	
2	Reserved	--	
3	Reserved	--	
4	Reserved	--	
5	Reserved	--	
6	Reserved	--	
7	Reserved	--	
9	Reserved	--	
10	Reserved	--	
11	Reserved	--	
14	Reserved	--	
15	Reserved	--	
16	Reserved	--	
17	Reserved	--	
18	Reserved	--	
19	Reserved	--	
20	Reserved	--	
21	Reserved	--	
23	Reserved	--	
24	Reserved	--	

Mating Connector	Aerotech P/N	Third Party P/N
25-Pin D-Connector	ECK00101	FCI DB25P064TXLF
Backshell	ECK00656	Amphenol 17E-1726-2

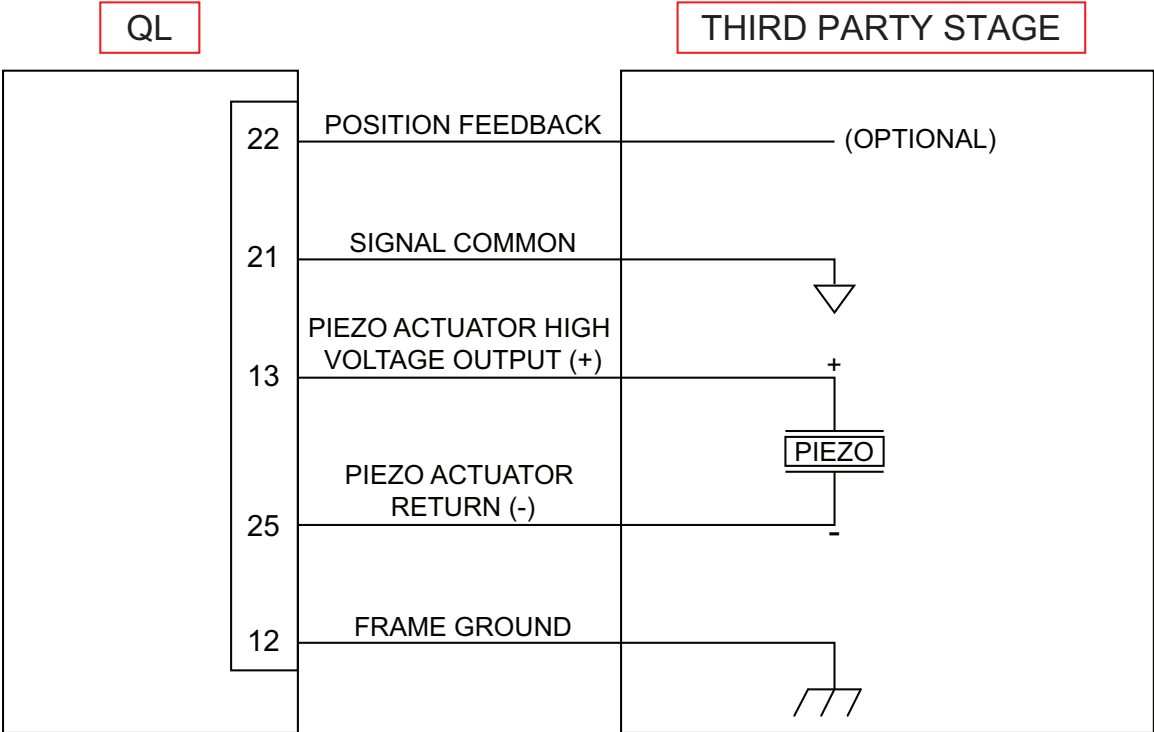

Figure 2-2: Connection to Third Party Stage

2.4. Auxiliary I/O Connector (J108)

The Auxiliary I/O connector provides 6 digital inputs, 1 analog input, 1 analog output, 4 digital outputs, bidirectional encoder port, and PSO outputs.

Table 2-4: Auxiliary I/O Interface Pin Assignment (J108)

Pin	Description	Connector
1	Aux Sine +	
2	Aux Sine -	
3	High Speed Input 4 +	
4	High Speed Input 4 -	
5	High Speed Input 5 +	
6	High Speed Input 5 -	
7	Opto-Isolated Output 0	
8	Opto-Isolated Output 1	
9	Opto-Isolated Output 2	
10	Aux Cosine +	
11	Aux Cosine -	
12	+5 Volt (500 mA max)	
13	Analog Input 0 + (Differential)	
14	Analog Input 0 - (Differential)	
15	Common for Opto-Isolated Outputs 0-3	
16	Opto-Isolated Output 3	
17	Opto-Isolated Input 0	
18	Opto-Isolated Input 1	
19	Aux Marker - / PSO ⁽¹⁾	
20	Aux Marker + / PSO ⁽¹⁾	
21	Common	
22	Analog Output 0	
23	Analog Common	
24	Common for Opto-Isolated Inputs 0-3	
25	Opto-Isolated Input 2	
26	Opto-Isolated Input 3	

1. For PSO, see [Section 2.4.1](#).

Mating Connector	Aerotech P/N	Third Party P/N
Connector	ECK01259	Kycon K86-AA-26P
Backshell	ECK01022	Amphenol 17-1725-2

NOTE: These items are provided as a set under the Aerotech P/N: MCK-26HDD.

2.4.1. Position Synchronized Output (PSO)

The PSO can be programmed to generate an output synchronized to the feedback position and is typically used to fire a laser or sequence an external device. Trigger signals may be derived from a feedback channel or a software trigger. The position synchronized output pulse is generated using high-speed hardware, allowing minimal latency between the trigger condition and the output.

The PSO output is available on the dual function AUX Marker/PSO signal lines as either a TTL or RS-422 formatted signal (software configurable).

An RS-422 line receiver or opto-isolator is recommended, especially when using long cable lengths in noisy environments or when high frequency pulse transmission is required. It is best to locate the line receiver or opto-isolator close to the receiving electronics.

Table 2-5: PSO Specifications

Specification		Value
Maximum Input Tracking Rate ⁽¹⁾	Single-Axis Tracking	16.6 MHz
Maximum Quadrature Encoder Output Frequency	Capacitance Sensor Feedback	16 MHz
Maximum PSO Output (Fire) Frequency ⁽²⁾		12.5 MHz
Firing Latency	Single-Axis Tracking	160 nsec
1. Signals in excess of this rate will cause a loss of PSO accuracy. 2. The optocoupler that you use on the output might have an effect on this rate.		

Table 2-6: PSO Output Pin Assignment (J108)

Pin	Description
19	Aux Marker - / PSO -
20	Aux Marker + / PSO +
21	Common

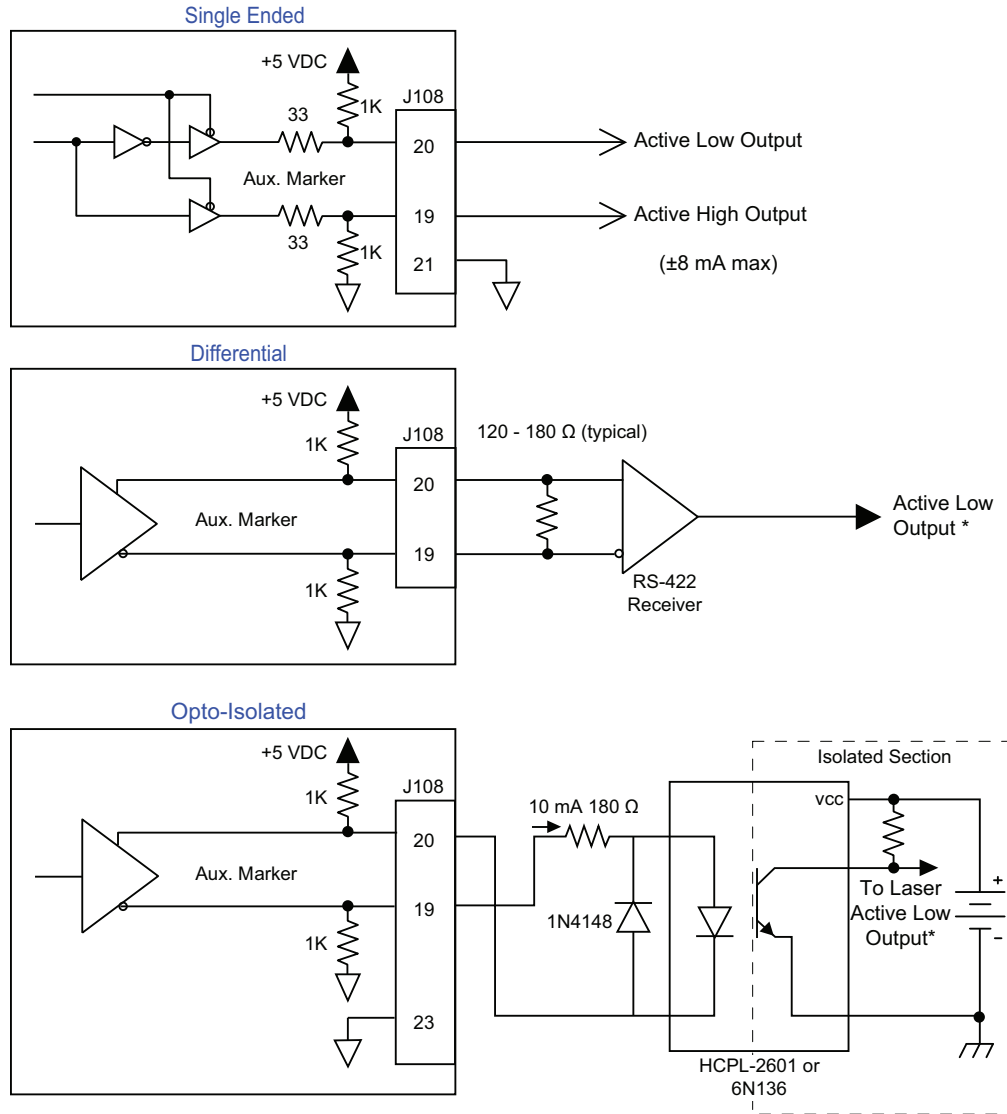

* Active low output shown. Opposite polarity available by reversing connections to Pins 19 and 20.

Figure 2-3: PSO Interface

2.4.2. Opto-Isolated Outputs 0-3

The digital outputs are optically-isolated and may be connected in sourcing or sinking configurations. The digital outputs are designed to connect to other ground referenced circuits and are not intended to provide high-voltage isolation.

Figure 2-4 and Figure 2-5 illustrate how to connect the outputs in current sourcing and current sinking modes, respectively.

The opto-isolator's common connections can be directly connected to the drive's power supply; however, doing so will effectively defeat the isolation and will reduce noise immunity.

Table 2-7: Digital Output Specifications

Opto Device Specifications	Value
Maximum Voltage	24 V maximum
Maximum Sink/Source Current (each output)	50 mA/output
Output Saturation Voltage	0.3 V at maximum current
Rise / Fall Time	250 usec (2K pull up to 24V)
Reset State	Output Off (High Impedance State)

Table 2-8: Digital Output Connector Pin Assignment (J108)

Pin	Description
7	Opto-Isolated Output 0
8	Opto-Isolated Output 1
9	Opto-Isolated Output 2
15	Common for Opto-Isolated Outputs 0-3
16	Opto-Isolated Output 3

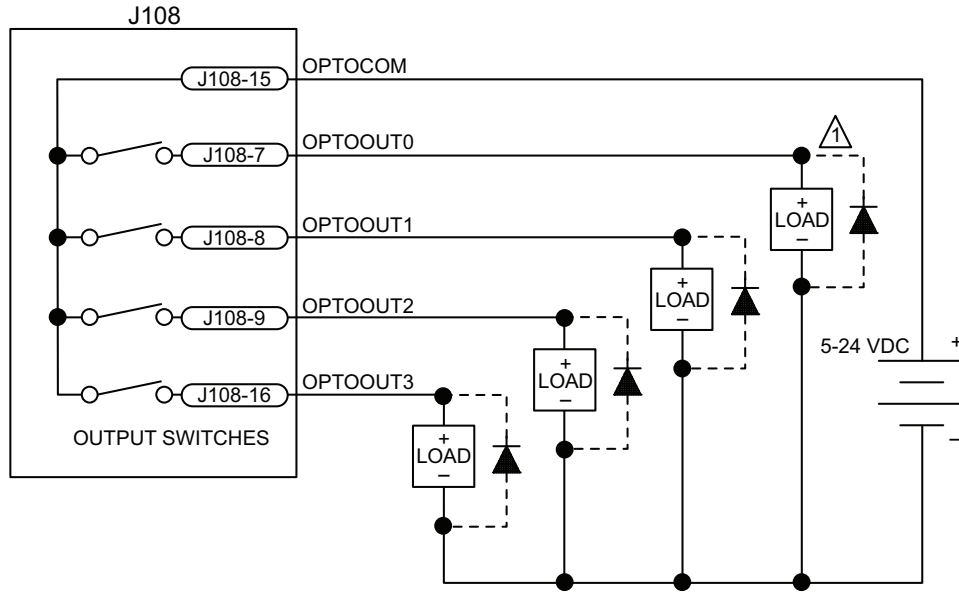

 DIODE REQUIRED ON EACH OUTPUT THAT DRIVES AN INDUCTIVE DEVICE (COIL), SUCH AS A RELAY.

Figure 2-4: Outputs Connected in Current Sourcing Mode (J108)

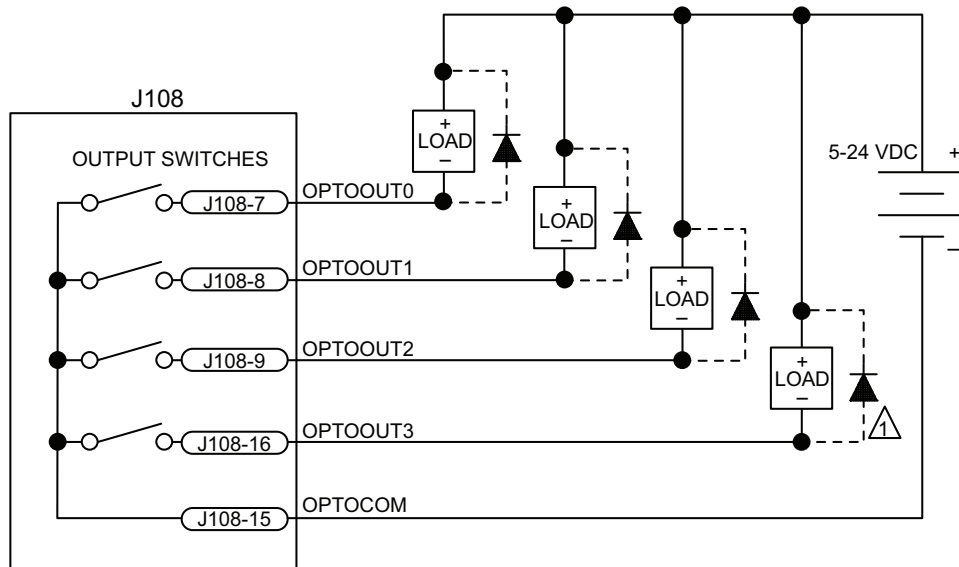

 DIODE REQUIRED ON EACH OUTPUT THAT DRIVES AN INDUCTIVE DEVICE (COIL), SUCH AS A RELAY.

Figure 2-5: Outputs Connected in Current Sinking Mode (J108)

2.4.3. Opto-Isolated Inputs 0-3

The digital inputs are opto-isolated and may be connected to current sourcing or current sinking devices, as shown in [Figure 2-6](#) and [Figure 2-7](#). These inputs are designed to connect to other ground-referenced circuits and are not intended for high-voltage isolation.

The opto-isolator's common connections can be directly connected to the drive's power supply; however, doing so will effectively defeat the isolation and will reduce noise immunity.

Table 2-9: PS2815-4 Opto-Device Specifications

Input Voltage	Approximate Input Current	Turn On/Off Time
5 to 24 V	5 mA	<100 usec

Table 2-10: Digital Input Connector Pin Assignment (J108)

Pin	Description
17	Opto-Isolated Input 0
18	Opto-Isolated Input 1
24	Common for Opto-Isolated Inputs 0-3
25	Opto-Isolated Input 2
26	Opto-Isolated Input 3

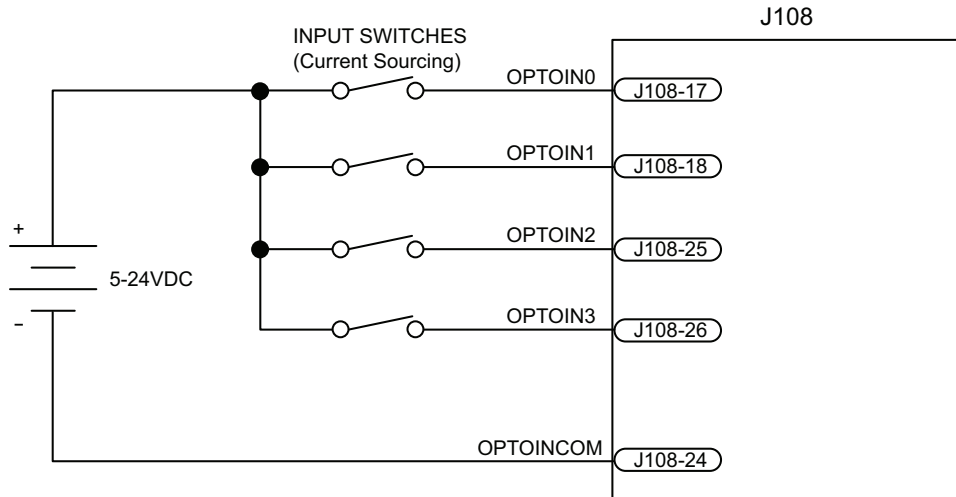

Figure 2-6: Inputs Connected in Current Sourcing Mode (J108)

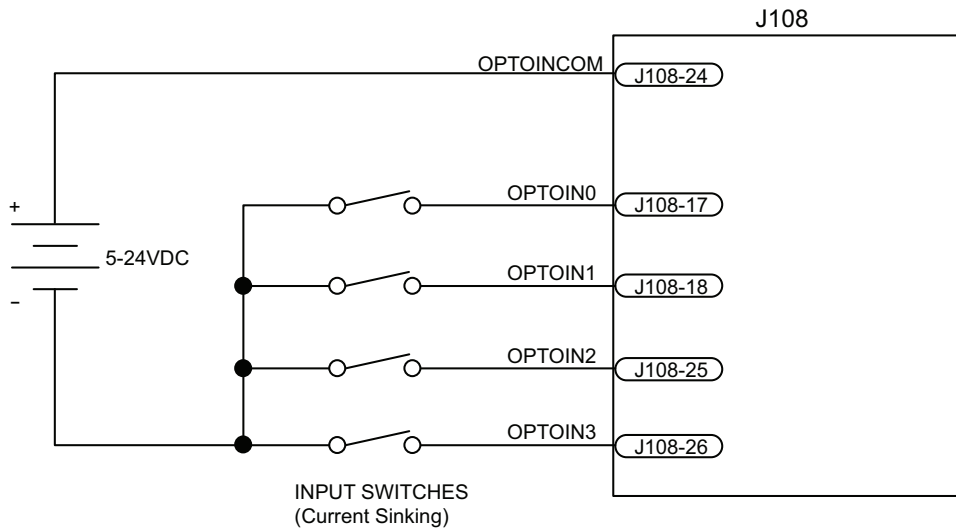

Figure 2-7: Inputs Connected in Current Sinking Mode (J108)

2.4.4. High-Speed User Inputs 4-5

The Ensemble QL has two high-speed opto-isolated inputs. These can be used as general purpose inputs or as high-speed position capture inputs.

Table 2-11: High Speed Digital Input Connector Pin Assignment (J108)

Pin	Description
3	High Speed Input 4 +
4	High Speed Input 4 -
5	High Speed Input 5 +
6	High Speed Input 5 -

Table 2-12: High-Speed Digital Input Specifications

Input Voltage	Input Current	Input Delay
5 to 24V	10 mA	50 ns

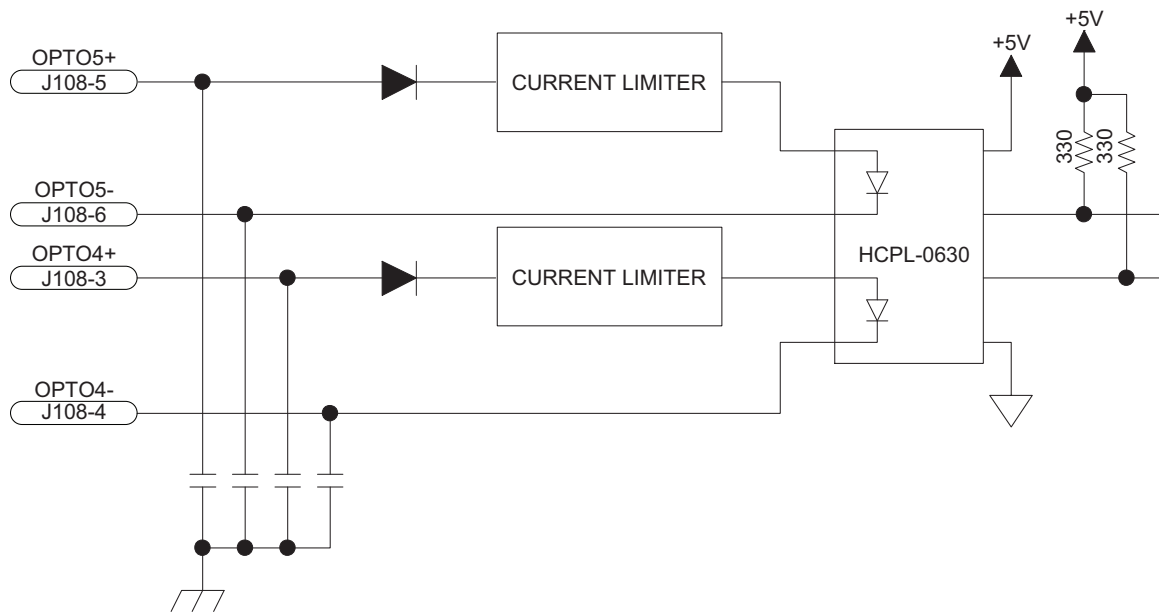

Figure 2-8: High Speed User Inputs (J108)

2.4.5. Analog Output 0

Table 2-13: Analog Output Specifications (J108)

Specification	Value
Output Voltage	-10 V to +10 V
Output Current	5 mA
Resolution (bits)	16 bits
Resolution (volts)	305 μ V

Table 2-14: Analog Output 0 Connector Pin Assignment (J108)

Pin	Description
22	Analog Output 0
23	Analog Common

2.4.6. Differential Analog Input 0

To interface to a single-ended (non-differential) voltage source, connect the signal common of the source to the negative input and the analog source signal to the positive input.

Table 2-15: Differential Analog Input Specifications (J108)

Specification	Value
(AI+) - (AI-)	+10 V to -10 V ⁽¹⁾
Resolution (bits)	16 bits
Resolution (volts)	305 μ V

1. Signals outside of this range may damage the input

Table 2-16: Analog Input Connector Pin Assignment (J108)

Pin	Description
13	Analog Input 0 + (Differential)
14	Analog Input 0 - (Differential)
23	Analog Common

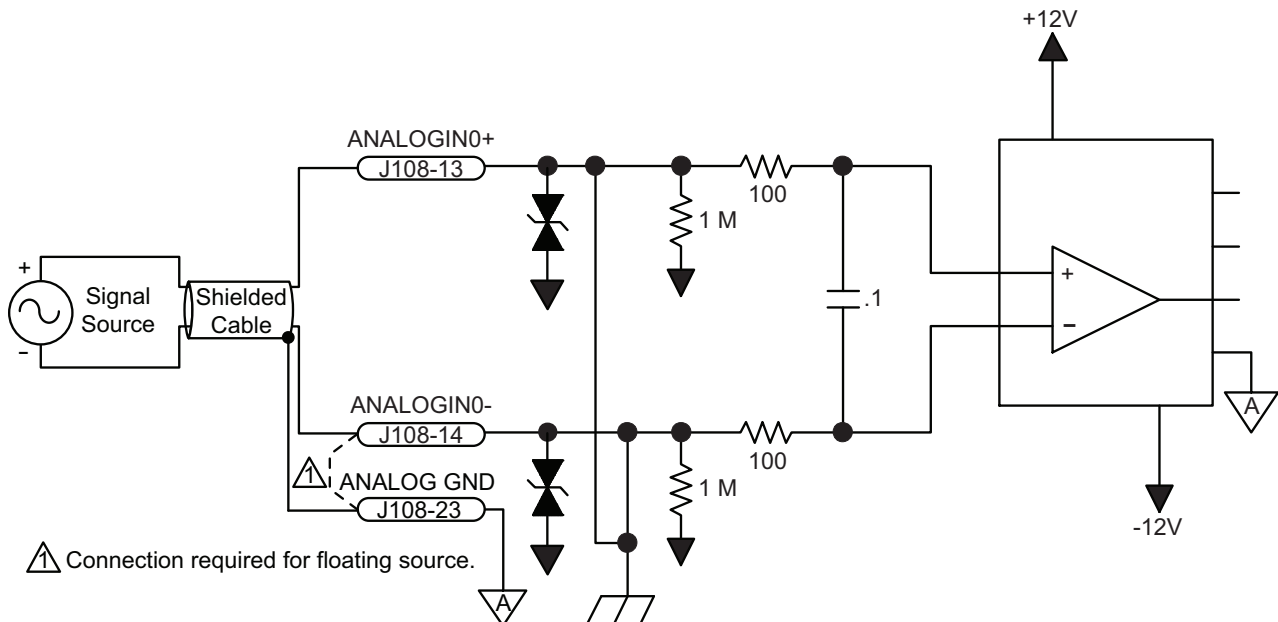
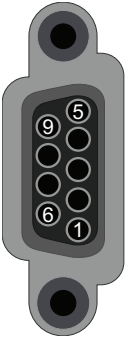

Figure 2-9: Analog Input 0 (J108)

2.5. Analog I/O Connector (J107)

The Analog I/O connector provides a piezo voltage monitor signal and an external voltage command input. The piezo voltage monitor signal is a scaled copy of the actual piezo actuator's high voltage signal. The external voltage command input allows the user to directly command the high-voltage amplifier.

Table 2-17: Analog I/O Connector Pin Assignment (J107)

Pin	Description	Connector
1	Reserved	
2	Reserved	
3	Reserved	
4	External Voltage Command	
5	Piezo Voltage Monitor	
6	Analog Common	
7	Analog Common	
8	Analog Common	
9	Reserved	

Mating Connector	Aerotech P/N	3rd Party P/N
Backshell	ECK01021	Amphenol DE24657
Connector	ECK00340	Cinch DE-9S

2.5.1. Voltage Monitor Output

The Voltage Monitor output provides a scaled copy of the piezo actuator's high-voltage signal. The high-voltage signal is scaled by 1/15 and buffered before being sent to the Voltage Monitor output pin.

Table 2-18: Voltage Monitor Output Connector Pin Assignment (J107)

Pin	Description
5	Piezo Voltage Monitor
8	Analog Common

Table 2-19: Voltage Monitor Output Scaling

Piezo Voltage	Voltage Monitor
+150 V	+10 V
0 V	0 V
-30 V	-2 V

Table 2-20: Voltage Monitor Output Specifications

	Description
Accuracy	$\pm 3.5\%$ Nominal
Recommended Load	$\geq 10\text{k } \Omega$

2.5.2. External Voltage Command

The External Voltage Command input allows the user to directly command the Ensemble QL's high voltage amplifier. This mode must be enabled using the controller software and is not active by default.

Table 2-21: External Voltage Command Connector Pin Assignment (J107)

Pin	Description
4	External Voltage Command
8	Analog Common

Table 2-22: External Voltage Command Scaling

External Voltage Command (Input)	Piezo Voltage (Output)
+10 V	+150 V
0 V	0 V
-2 V	-30 V

Table 2-23: External Voltage Command Specifications

	Description
Input Range	-2V to +10V
Input Impedance	20k Ω

2.6. Communication

Either USB or Ethernet can be used to connect any of the supplied software applications or a custom application built with the supplied .NET library to the controller. Ethernet sockets are also available for general ASCII communication with another hardware device. Refer to the Help file for more information about the ASCII interface.

2.6.1. USB Interface

The USB connection is established through a Type B female connector labeled USB on the QL (refer to [Figure 2-10](#)). This can be accomplished by one of these two methods:

Method 1: Directly connect to the PC with a standard USB cable. The cable connector type must be Type A or Type B male depending on the PC, and Type B male on the QL.

Method 2: Connect through a USB hub. The cable connector type must be Type A or Type B male depending on the hub, and Type B male on the QL.

Method 1 is the most commonly used. Method 2 is necessary only when the number of QLs to be connected is larger than the number of available USB ports on the PC.

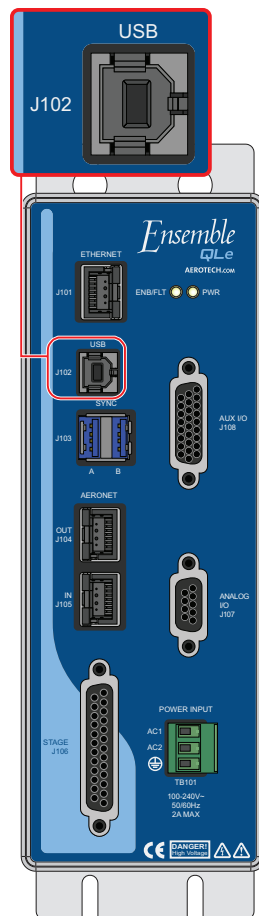

Figure 2-10: USB Connection Location

2.6.2. Ethernet Interface

The Ethernet interface is the high-speed communications media to the QL. Command and configuration information is sent through this interface.

The Ethernet connection is established through the RJ-45 connector labeled ETHERNET on the QL (refer to [Figure 2-11](#)). Connection is accomplished by one of these two methods:

Method 1: Directly connect to the PC with an RJ-45 crossover cable.

Method 2: Connect through a network with a standard RJ-45 cable.

Method 1 is the most secure because it guarantees that the only members of the network are the QL and the PC. This type of connection is not feasible unless the PC has two Ethernet cards. If the PC cannot be connected to an external network, Aerotech recommends Method 2.

Method 2 is a more typical configuration. The network can be a local network (the PC and QL are connected through a hub or switch) or remote (the devices are connected through a router). When connecting to a remote network, a crossover cable cannot be used; instead, there must be a hub, switch, or router interface between the PC and the QL.

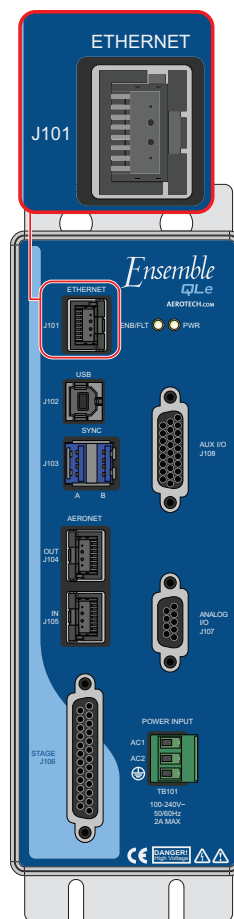

Figure 2-11: Ethernet Connection Location

2.6.3. Aeronet Interface

Use this option to connect up to ten Ensemble discrete drives.

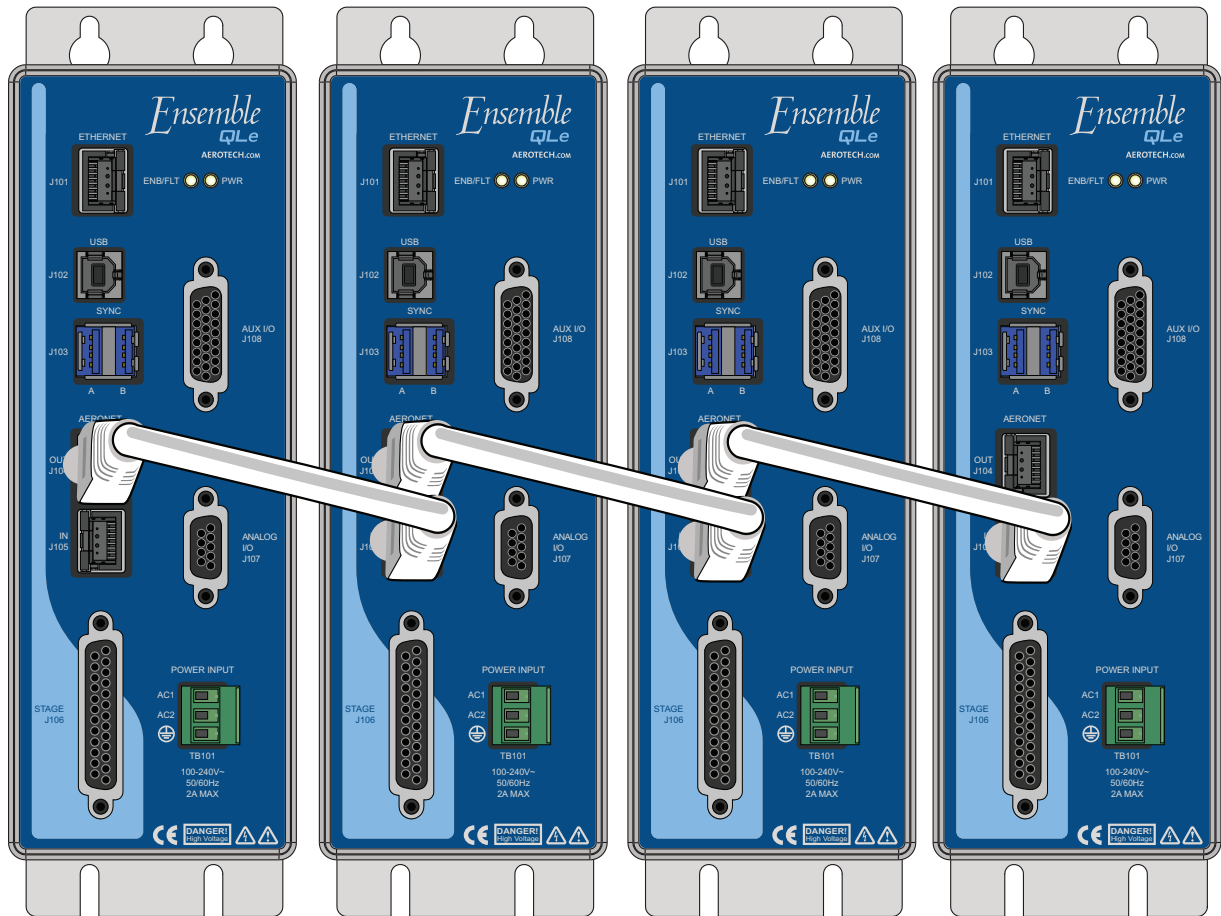

Figure 2-12: Aeronet Connections

Table 2-24: Aeronet Cable Part Numbers

Cable Part Number	Length
ENET-CAT6-3	A CAT6 cable; length is 3 decimeters
ENET-CAT6-10	A CAT6 cable; length is 10 decimeters
ENET-CAT6-20	A CAT6 cable; length is 20 decimeters
ENET-CAT6-30	A CAT6 cable; length is 30 decimeters
ENET-CAT6-45	A CAT6 cable; length is 45 decimeters
ENET-CAT6-76	A CAT6 cable; length is 76 decimeters
ENET-CAT6-90	A CAT6 cable; length is 90 decimeters
Cable lengths are in decimeters, 10dm = 1 meter = 3.28 feet	

2.6.4. SYNC Interface

The Sync connection contains a proprietary bus which is currently reserved for future expansion.

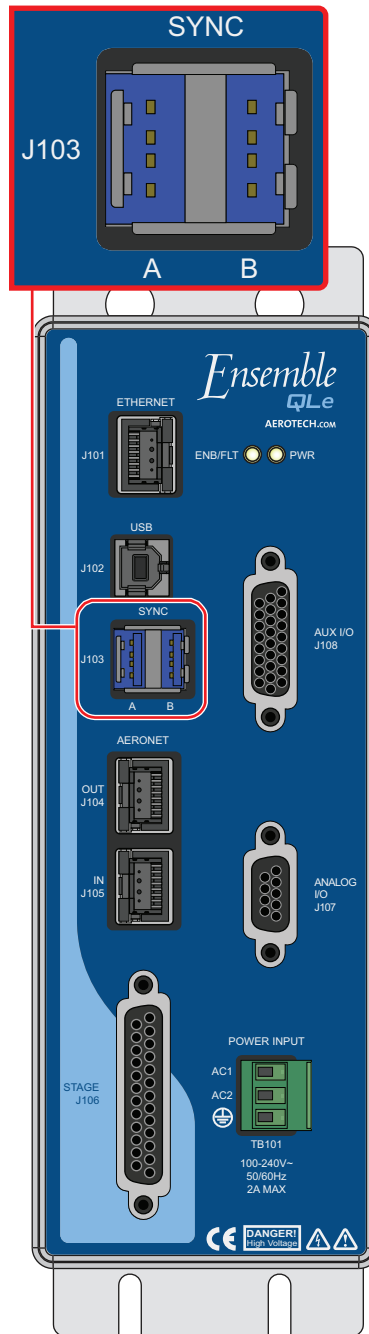

Figure 2-13: Sync Interface

2.7. PC Configuration and Operation Information

For additional information about PC configuration, hardware requirements, programming, utilities, and system operation refer to the Help file.

This page intentionally left blank.

Chapter 3: Maintenance



DANGER: For your own safety and for the safety of the equipment, do not remove the cover of the Ensemble QL or attempt to access its internal components.

There is no reason to remove the cover or access the internal components. The QL does not have any user-configurable switches or jumpers. Internal fuses are not user-replaceable.

NOTE: Having to replace a fuse indicates a more serious problem with the system or setup; consult Aerotech for assistance.

Table 3-1: LED Description

LED	Description
PWR	Turns green when power is applied.
ENB/FLT	Turns Red during initial system start-up for approximately 20 seconds then Green: Piezo is being controlled (Open or Closed Loop) Red: Fault Condition Off: Piezo is not actively controlled

Table 3-2: Troubleshooting

Symptom	Possible Cause and Solution
No Communication	Make sure the power LED is illuminated (this indicates that AC power is present).
	Make sure the Ethernet or USB cables are fully inserted in the port.

3.1. Preventative Maintenance

The Ensemble QL and external wiring should be inspected monthly. Inspections may be required at more frequent intervals, depending on the environment and use of the system.

Table 3-3: Preventative Maintenance

Check	Action to be Taken
Visually Check chassis for loose or damaged parts / hardware. Note: Internal inspection is not required.	Parts should be repaired as required. If internal damage is suspected, these parts should be checked and repairs made if necessary.
Inspect cooling vents.	Remove any accumulated material from vents.
Check for fluids or electrically conductive material exposure.	Any fluids or electrically conductive material must not be permitted to enter the Ensemble QL.
Visually inspect all cables and connections.	Tighten or re-secure any loose connections. Replace worn or frayed cables. Replace broken connectors.

Cleaning

The Ensemble QL chassis can be wiped with a clean, dry, soft cloth. The cloth may be slightly moistened if required with water or isopropyl alcohol to aid in cleaning if necessary. In this case, be careful not to allow moisture to enter the Ensemble QL or onto exposed connectors / components. Fluids and sprays are not recommended because of the chance for internal contamination, which may result in electrical shorts and/or corrosion. The electrical power must be disconnected from the Ensemble QL while cleaning. Do not allow cleaning substances or other fluids to enter the Ensemble QL or to get on to any of the connectors. Avoid cleaning labels to prevent removing the label information.

Appendix A: Warranty and Field Service

Aerotech, Inc. warrants its products to be free from harmful defects caused by faulty materials or poor workmanship for a minimum period of one year from date of shipment from Aerotech. Aerotech's liability is limited to replacing, repairing or issuing credit, at its option, for any products that are returned by the original purchaser during the warranty period. Aerotech makes no warranty that its products are fit for the use or purpose to which they may be put by the buyer, whether or not such use or purpose has been disclosed to Aerotech in specifications or drawings previously or subsequently provided, or whether or not Aerotech's products are specifically designed and/or manufactured for buyer's use or purpose. Aerotech's liability on any claim for loss or damage arising out of the sale, resale, or use of any of its products shall in no event exceed the selling price of the unit.

THE EXPRESS WARRANTY SET FORTH HEREIN IS IN LIEU OF AND EXCLUDES ALL OTHER WARRANTIES, EXPRESSED OR IMPLIED, BY OPERATION OF LAW OR OTHERWISE. IN NO EVENT SHALL AEROTECH BE LIABLE FOR CONSEQUENTIAL OR SPECIAL DAMAGES.

Return Products Procedure

Claims for shipment damage (evident or concealed) must be filed with the carrier by the buyer. Aerotech must be notified within thirty (30) days of shipment of incorrect material. No product may be returned, whether in warranty or out of warranty, without first obtaining approval from Aerotech. No credit will be given nor repairs made for products returned without such approval. A "Return Materials Authorization (RMA)" number must accompany any returned product(s). The RMA number may be obtained by calling an Aerotech service center or by submitting the appropriate request available on our website (www.aerotech.com). Products must be returned, prepaid, to an Aerotech service center (no C.O.D. or Collect Freight accepted). The status of any product returned later than thirty (30) days after the issuance of a return authorization number will be subject to review.

Visit <https://www.aerotech.com/global-technical-support.aspx> for the location of your nearest Aerotech Service center.

Returned Product Warranty Determination

After Aerotech's examination, warranty or out-of-warranty status will be determined. If upon Aerotech's examination a warranted defect exists, then the product(s) will be repaired at no charge and shipped, prepaid, back to the buyer. If the buyer desires an expedited method of return, the product(s) will be shipped collect. Warranty repairs do not extend the original warranty period.

Fixed Fee Repairs - Products having fixed-fee pricing will require a valid purchase order or credit card particulars before any service work can begin.

All Other Repairs - After Aerotech's evaluation, the buyer shall be notified of the repair cost. At such time the buyer must issue a valid purchase order to cover the cost of the repair and freight, or authorize the product(s) to be shipped back as is, at the buyer's expense. Failure to obtain a purchase order number or approval within thirty (30) days of notification will result in the product(s) being returned as is, at the buyer's expense.

Repair work is warranted for ninety (90) days from date of shipment. Replacement components are warranted for one year from date of shipment.

Rush Service

At times, the buyer may desire to expedite a repair. Regardless of warranty or out-of-warranty status, the buyer must issue a valid purchase order to cover the added rush service cost. Rush service is subject to Aerotech's approval.

On-site Warranty Repair

If an Aerotech product cannot be made functional by telephone assistance or by sending and having the customer install replacement parts, and cannot be returned to the Aerotech service center for repair, and if Aerotech determines the problem could be warranty-related, then the following policy applies:

Aerotech will provide an on-site Field Service Representative in a reasonable amount of time, provided that the customer issues a valid purchase order to Aerotech covering all transportation and subsistence costs. For warranty field repairs, the customer will not be charged for the cost of labor and material. If service is rendered at times other than normal work periods, then special rates apply.

If during the on-site repair it is determined the problem is not warranty related, then the terms and conditions stated in the following "On-Site Non-Warranty Repair" section apply.

On-site Non-Warranty Repair

If any Aerotech product cannot be made functional by telephone assistance or purchased replacement parts, and cannot be returned to the Aerotech service center for repair, then the following field service policy applies:

Aerotech will provide an on-site Field Service Representative in a reasonable amount of time, provided that the customer issues a valid purchase order to Aerotech covering all transportation and subsistence costs and the prevailing labor cost, including travel time, necessary to complete the repair.

Service Locations

<http://www.aerotech.com/contact-sales.aspx?mapState=showMap>

USA, CANADA, MEXICO	CHINA	GERMANY
Aerotech, Inc. Global Headquarters Phone: +1-412-967-6440 Fax: +1-412-967-6870	Aerotech China Full-Service Subsidiary Phone: +86 (21) 3319 7715	Aerotech Germany Full-Service Subsidiary Phone: +49 (0)911 967 9370 Fax: +49 (0)911 967 93720
JAPAN	TAIWAN	UNITED KINGDOM
Aerotech Japan Full-Service Subsidiary Phone: +81 (0)50 5830 6814 Fax: +81 (0)43 306 3773	Aerotech Taiwan Full-Service Subsidiary Phone: +886 (0)2 8751 6690	Aerotech United Kingdom Full-Service Subsidiary Phone: +44 (0)1256 855055 Fax: +44 (0)1256 855649

Have your customer order number ready before calling.

Appendix B: Revision History

Revision	Description
1.03.00	Updated the connector pinout: Section 2.5. Analog I/O Connector (J107)
1.02.00	Updated the connector pinout: Section 2.5. Analog I/O Connector (J107)
1.01.00	The following sections have been updated: <ul style="list-style-type: none">• EU Declaration of Conformity• Agency Approvals• Section 1.1. Electrical Specifications• Section 2.1. Unpacking the Chassis• Section 2.2.2. I/O and Signal Wiring Requirements• Section 2.4.1. Position Synchronized Output (PSO)• Section 2.4.2. Opto-Isolated Outputs 0-3• Section 2.4.3. Opto-Isolated Inputs 0-3• Section 2.4.5. Analog Output 0• Section 2.4.6. Differential Analog Input 0• Section 0.0.1. Analog Output 1• Section 0.0.1. Differential Analog Input 1
1.00.00	New manual

This page intentionally left blank.

Index

		inspect all cables and connections	44
	2	Inspect cooling vents	44
2014/35/EU		Inspection	44
	A	Installation and Configuration	19
Altitude		M	
Ambient Temperature		Mechanical Design	17
	C	P	
Check chassis for loose or damaged parts / hardware		Peak Inrush Current	16
		Peak Output Current	16
Check for fluids or electrically conductive material exposure		Piezo Actuator Output Voltage	16
Cleaning		Pollution	18
Continuous Output Current		Power Supply	16
	D	PS2815-4 Opto-Device Specifications	29
Declaration of Conformity		PSO Output Sources	25
Digital Output Specifications		Q	
dimensions		Quick Installation Guide	11
	E	Quick Start Connections	11
Electrical Specifications		S	
Environmental Specifications		Sensor Resolution	16
	F	Servo Loop Update	16
Functional Diagram		shipping damage	19
fuse		Support	2
	G	T	
Global Technical Support		Technical Support	2
	H	U	
High-Speed Data Capture		unit weight	17
Humidity		Use	18
	I	V	
Input Frequency		Voltage Resolution	16
Input Power		W	
Input Voltage		Warm Up Time	16
inspect			

This page intentionally left blank.