



Mechanical Bearing, Ball-Screw Stage

PRO115SL



Precise & Robust Linear Motion for All

The PRO115SL is a compact stage that excels in medium- and high-performance industrial applications. Combining superior craftsmanship and the highest quality components, PRO115SL stages consistently and reliably deliver best-in-class positioning performance. Thoughtfully engineered features and options, coupled with competitive pricing, make PRO115SL stages the ideal choice for streamlined integration into a wide variety of precision systems, machines and processes.

Key Applications

PRO115SL mechanical bearing, ball-screw stages are extremely versatile, trusted and proven in medium- and high-performance applications, such as:

- ◆ Laser material processing
- ◆ Precision metrology, inspection & microscopy
- ◆ Electronics & circuit board manufacturing & inspection
- ◆ Display processing
- ◆ Synchrotron & light source experiments
- ◆ Medical device manufacturing
- ◆ Semiconductor fabrication
- ◆ Fiber optics & silicon photonics processing
- ◆ Additive manufacturing & precision assembly

KEY FEATURES:

- ◆ Compact design **SIMPLIFIES INTEGRATION IN SPACE-CONSTRAINED APPLICATIONS**
- ◆ **BEST-IN-CLASS GEOMETRIC PERFORMANCE** ensures superior workpoint accuracy
- ◆ **EXCELLENT MOTION & POSITIONING PERFORMANCE** in a cost-effective package
- ◆ Rugged, reliable construction is ideal for **VERSATILE INDUSTRIAL USE**
- ◆ Hardcover & side seals offer **PROTECTION AGAINST CONTAMINATION & PARTICULATES**
- ◆ **VACUUM- & CLEANROOM-COMPATIBLE** versions available

PR0115SL SPECIFICATIONS

| Mechanical Specifications | | PR0115SL | | | | | |
|--|-------------------------|---|----------|---------|----------|---------|---------|
| Travel | | 50 | 100 | 150 | 200 | 300 | 400 |
| Accuracy⁽¹⁾ | Standard | ±6 µm | ±6 µm | ±8 µm | ±8 µm | ±10 µm | ±12 µm |
| | Calibrated | ±1 µm | ±1.25 µm | ±1.5 µm | ±1.75 µm | ±2.5 µm | ±3 µm |
| Resolution (Min. Incremental Motion) | | 0.1 µm ⁽²⁾ ; 1.0 µm ⁽³⁾ | | | | | |
| Bidirectional Repeatability⁽¹⁾ | | ±1 µm | ±1 µm | ±1 µm | ±1 µm | ±1 µm | ±1 µm |
| Horizontal Straightness⁽¹⁾ | | ±1.5 µm | ±2.5 µm | ±3 µm | ±4 µm | ±6 µm | ±8 µm |
| Vertical Straightness⁽¹⁾ | | ±1.5 µm | ±2.5 µm | ±3 µm | ±4 µm | ±6 µm | ±8 µm |
| Pitch | | 19 µrad | 29 µrad | 29 µrad | 39 µrad | 58 µrad | 78 µrad |
| Roll | | 19 µrad | 29 µrad | 29 µrad | 39 µrad | 58 µrad | 78 µrad |
| Yaw | | 19 µrad | 29 µrad | 29 µrad | 39 µrad | 58 µrad | 78 µrad |
| Maximum Speed⁽⁴⁾ | | 300 mm/s | | | | | |
| Maximum Acceleration⁽⁴⁾ | | Function of Motor, Amplifier Selection, Payload, and Maximum Axial Load | | | | | |
| Load Capacity⁽⁵⁾ | Horizontal | 40 kg | | | | | |
| | Vertical (Axial) | 18 kg | | | | | |
| | Side | 40 kg | | | | | |
| Moving Mass (w/Tabletop) | | 1.4 kg | | | | | |
| Stage Mass (No Motor) | | 4.0 kg | 4.4 kg | 4.8 kg | 5.2 kg | 6.0 kg | 6.8 kg |
| Material | | Anodized Aluminum | | | | | |
| MTBF (Mean Time Between Failure) | | 20,000 Hours | | | | | |

Notes:

1. Certified with -PL1/PL2 options.
2. Achieved with Aerotech rotary motor with amplified sine encoder.
3. Achieved with Aerotech rotary motor with 2500 cnts/rev digital encoder.
4. Requires the selection of an appropriate amplifier with sufficient voltage and current.
5. Axis-orientation for on-axis loading is listed.
6. Specifications are for single-axis systems measured 25 mm above the tabletop. Performance of multi-axis systems is payload and workpoint dependent. Contact factory for multi-axis applications.
7. Specifications listed are non-foldback kit options. Contact factory for specifications when a foldback kit (-FBx) is used.

| Electrical Specifications | |
|--|---|
| Drive System | Brushless Rotary Servomotor |
| Feedback (Rotary Encoder)⁽¹⁾ | Incremental – 1000 lines/rev (1 Vpp) and 2500 lines/rev (Digital RS422) |
| Maximum Bus Voltage | 340 VDC |
| Limit Switches | 5 V, Normally-Closed |

Notes:

1. Requires the selection of a motor option.

PR0115SL ORDERING OPTIONS

Travel (Required)

- 050 50 mm travel stage
- 100 100 mm travel stage
- 150 150 mm travel stage
- 200 200 mm travel stage
- 300 300 mm travel stage
- 400 400 mm travel stage

Other travel options are available upon request. Contact Aerotech for more information.

Tabletop (Optional)

- TT1 Tabletop with metric dimension mounting

Other tabletop options are available upon request. Contact Aerotech for more information.

Motor (Optional)

- M5 BM75 brushless servomotor and 2500-line TTL encoder
- M6 BM75 brushless servomotor, 2500-line TTL encoder, and brake
- M7 BM75 brushless servomotor and 1000-line 1 Vpp encoder
- M8 BM75 brushless servomotor, 1000-line 1 Vpp encoder, and brake

Other motor options are available upon request. Contact Aerotech for more information.

Foldback (Optional)

- FB1 Foldback kit for 0.250 inch diameter shaft NEMA 23 motor

Note: TT option required for lower axis of XY when a foldback kit is used.

Motor Orientation (Optional)

- 2 Bottom cable exit, optional orientation
- 3 Left-side cable exit, standard orientation
- 8 Right-side foldback, standard orientation

Other motor orientation options are available upon request. Contact Aerotech for more information.

Limits (Required)

- LI1 Normally-closed limit switches; 5 VDC with 9-Pin D connector

Other limit options are available upon request. Contact Aerotech for more information.

Coupling (Optional)

- CP1 Coupling for 0.250 inch diameter shaft

Other coupling options are available upon request. Contact Aerotech for more information.

Metrology (Required)

- PL0 No metrology performance plots
- PL1 Metrology, uncalibrated with performance plots
- PL2 Metrology, calibrated (HALAR) with performance plots

PRO115SL ORDERING OPTIONS

Integration (Required)

Aerotech offers both standard and custom integration services to help you get your system fully operational as quickly as possible. The following standard integration options are available for this system. Please consult Aerotech if you are unsure what level of integration is required or if you desire custom integration support with your system.

-TAS Integration - Test as system

Testing, integration and documentation of a group of components as a complete system that will be used together (ex: drive, controller and stage). This includes parameter file generation, system tuning and documentation of the system configuration.

-TAC Integration - Test as components

Testing and integration of individual items as discrete components. This is typically used for spare parts, replacement parts or items that will not be used or shipped together (ex: stage only). These components may or may not be part of a larger system.

Accessories (To Be Ordered As Separate Line Item)

| | |
|--------------------|--|
| ALIGN-NPA | Non-precision XY assembly |
| ALIGN-NPAZ | Non-precision XZ or YZ assembly |
| ALIGN-PA10 | XY assembly; 10 arc sec orthogonality. Alignment to within 7 microns orthogonality for short travel stages. |
| ALIGN-PA10Z | XZ or YZ assembly with L-bracket; 10 arc second orthogonality. Alignment to within 10 microns orthogonality for short travel stages. |
| ALIGN-PA5 | XY assembly; 5 arc sec orthogonality. Alignment to within 3 microns orthogonality for short travel stages. |
| ALIGN-PA5Z | XZ or YZ assembly with L-bracket; 5 arc second orthogonality. Alignment to within 5 microns orthogonality for short travel stages. |
| HDZ115 | Right angle L-bracket for PRO115SL/SLE-050, PRO115SL/SLE-100, and PRO115SL/SLE-50 only. |

Note: HDZ bracket requires a tabletop when mounting to a PRO stage.

PRO115SL SPECIFICATIONS

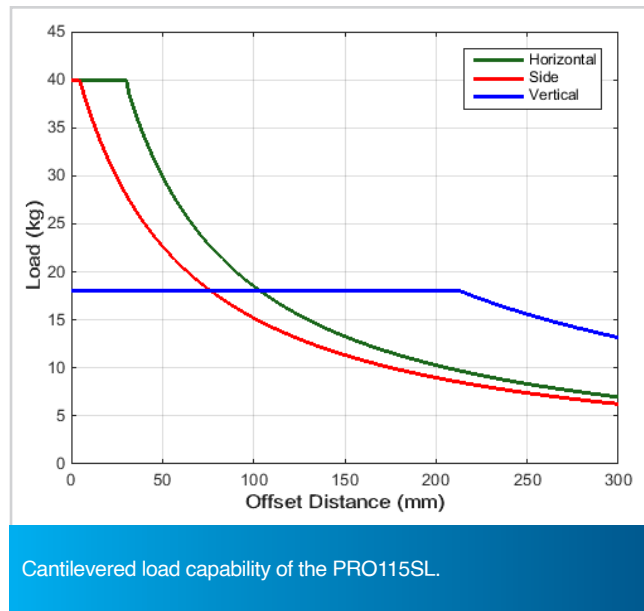

PRO115SL DIMENSIONS

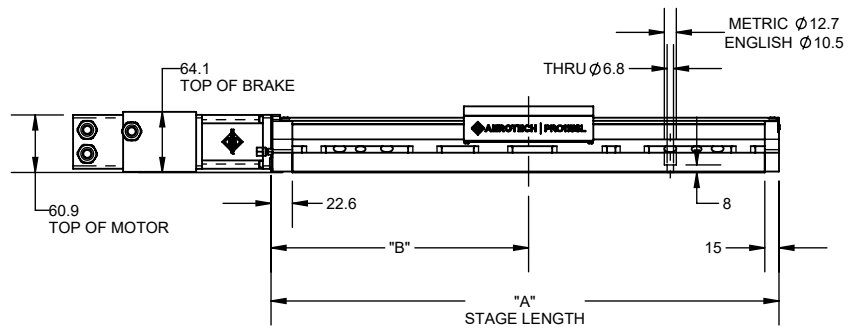
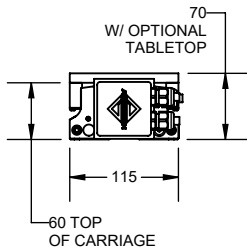
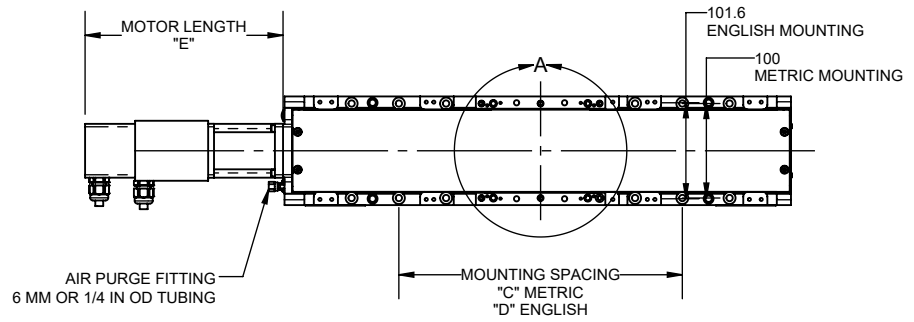
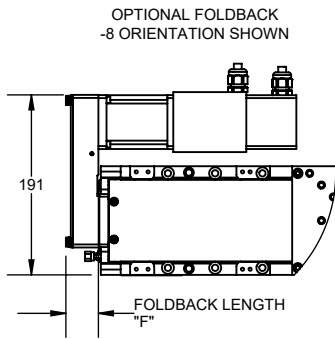
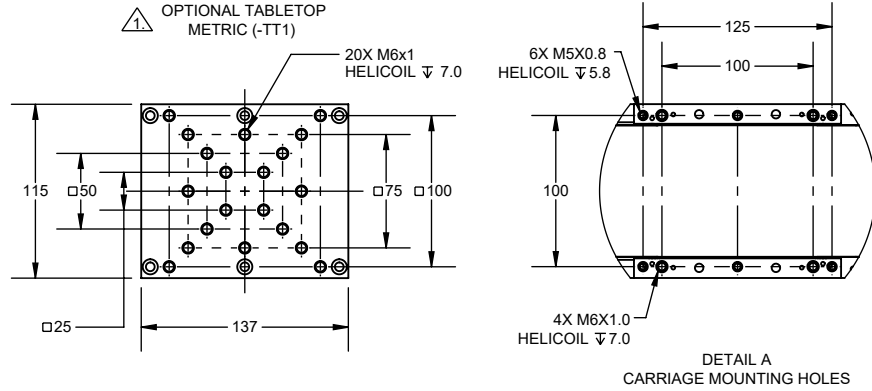
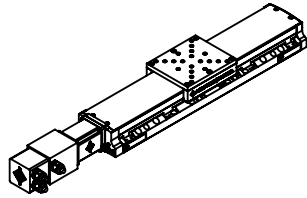

| | DIMENSION |
|----------|-----------|
| OPTION | E |
| -M5, -M7 | 132.3 |
| -M6, -M8 | 209.5 |
| | F |
| -FB1, | 35.4 |

| BASIC MODEL | NOMINAL TRAVEL | ELEC LIMIT TRAVEL | MECH LIMIT TRAVEL | A | B | C | D |
|--------------|----------------|-------------------|-------------------|-------|-------|-------------------------|--------------|
| PRO115SL-050 | 50 | 58.4-63.2 | 75 | 287.6 | 147.6 | 100 | 101.6 |
| PRO115SL-100 | 100 | 109.2-114 | 125 | 337.6 | 172.6 | 100, 200 | 101.6 |
| PRO115SL-150 | 150 | 160-164.8 | 175 | 387.6 | 197.6 | 100, 200 | 101.6 |
| PRO115SL-200 | 200 | 210.8-215.6 | 225 | 437.6 | 222.6 | 100, 200, 300 | 101.6 |
| PRO115SL-300 | 300 | 312.4-317.2 | 325 | 537.6 | 272.6 | 100, 200, 300, 400 | 101.6, 355.6 |
| PRO115SL-400 | 400 | 414-418.8 | 425 | 637.6 | 322.6 | 100, 200, 300, 400, 500 | 101.6, 457.2 |

NOTES:

▲ -TT1 TABLETOP OPTION REQUIRED FOR LOWER AXIS OF XY ASSEMBLIES WHEN FOLDBACK OPTION IS CHOSEN.

2. DIMENSIONS: MILLIMETERS.

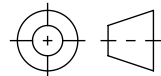

PRO115SL HDZ BRACKET DIMENSIONS

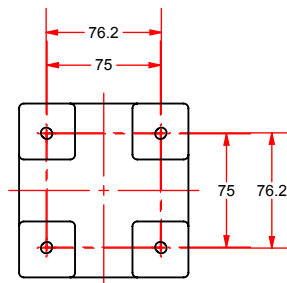
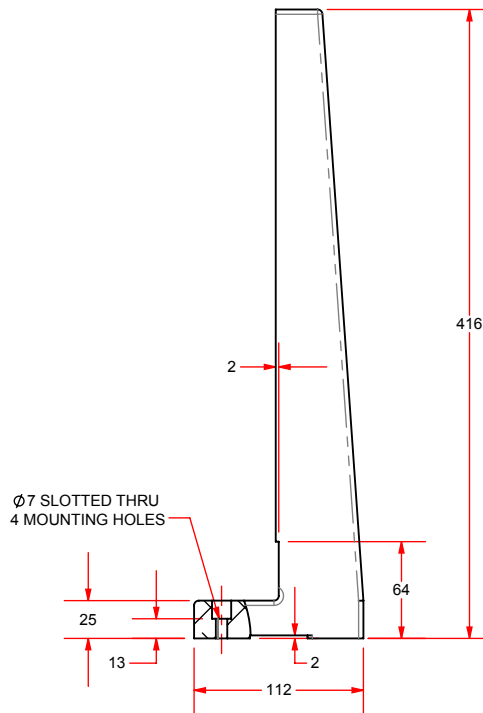
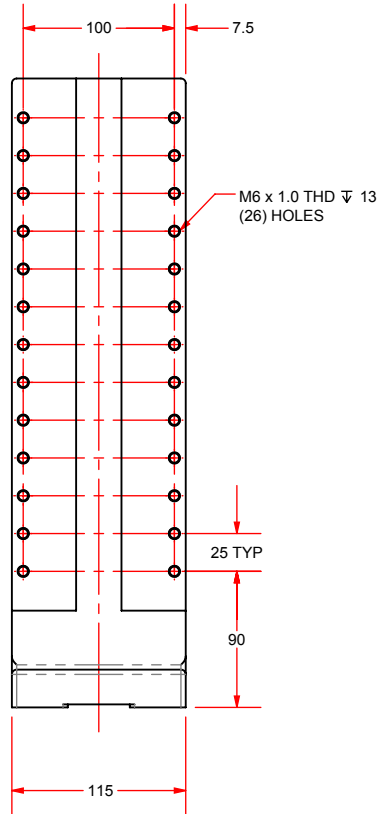
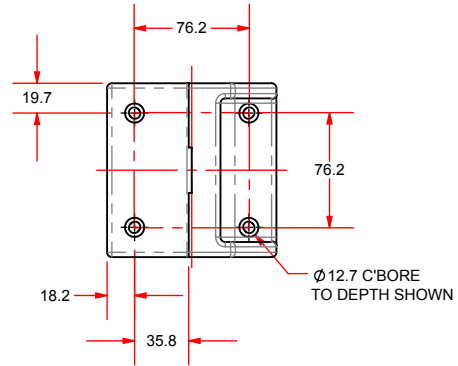

| BASIC MODEL | RECOMMENDED FOR | MASS [kg] |
|-------------|--|-----------|
| HDZ115 | PRO115SL-050, PRO115SL-100, PRO115SL-150 | 3.7 |

DIMENSIONS: MILLIMETERS

