



Mechanical Bearing, Direct-Drive Linear Stage

PRO225LM



Precise, Reliable & Adaptable

The PRO225LM provides an optimal balance of positioning performance, payload capacity and size. Compared to the narrower PRO190LM, PRO225LM is capable of carrying considerably higher payloads due to its larger bearings and motor. Combining superior craftsmanship and the highest quality components, PRO225LM stages consistently and reliably deliver best-in-class positioning performance.

Key Applications

PRO225LM mechanical bearing, direct-drive linear stages are extremely versatile, trusted and proven in medium- and high-performance applications, such as:

- ◆ Laser material processing
- ◆ Precision metrology, inspection & microscopy
- ◆ Electronics & circuit board manufacturing & inspection
- ◆ Display processing
- ◆ Synchrotron & light source experiments
- ◆ Medical device manufacturing
- ◆ Semiconductor fabrication
- ◆ Fiber optics & silicon photonics processing
- ◆ Additive manufacturing & precision assembly

KEY FEATURES:

- ◆ Provides **SUBSTANTIAL PAYLOAD-CARRYING CAPACITY**
- ◆ Ironless, cogless linear motor delivers **SMOOTH, ULTRA-PRECISE MOTION**
- ◆ **EXCELLENT POSITIONING & DYNAMIC CAPABILITIES** in a cost-effective package
- ◆ **BEST-IN-CLASS GEOMETRIC PERFORMANCE** ensures superior workpoint accuracy
- ◆ Rugged, reliable construction is ideal for **VERSATILE INDUSTRIAL USE**
- ◆ Hardcover & side seals offer **PROTECTION AGAINST CONTAMINATION & PARTICULATES**
- ◆ ThermoComp® option automatically **COMPENSATES FOR THERMAL DISTURBANCES**
- ◆ **VACUUM- & CLEANROOM-COMPATIBLE** versions available

PRO225LM SPECIFICATIONS

Mechanical Specifications		PRO225LM			
Travel		100	200	300	400
Accuracy⁽¹⁾	Standard	$\pm 4 \mu\text{m}$	$\pm 8 \mu\text{m}$	$\pm 10 \mu\text{m}$	$\pm 12 \mu\text{m}$
	Calibrated	$\pm 1 \mu\text{m}$	$\pm 1 \mu\text{m}$	$\pm 1 \mu\text{m}$	$\pm 1 \mu\text{m}$
Resolution (Min. Incremental Motion)		5 nm (-E1 Encoder)			
Bidirectional Repeatability⁽¹⁾		$\pm 0.3 \mu\text{m}$	$\pm 0.4 \mu\text{m}$	$\pm 0.4 \mu\text{m}$	$\pm 0.4 \mu\text{m}$
Horizontal Straightness⁽¹⁾		$\pm 1.5 \mu\text{m}$	$\pm 2.5 \mu\text{m}$	$\pm 3.5 \mu\text{m}$	$\pm 4.5 \mu\text{m}$
Vertical Straightness⁽¹⁾		$\pm 1.5 \mu\text{m}$	$\pm 2.5 \mu\text{m}$	$\pm 3.5 \mu\text{m}$	$\pm 4.5 \mu\text{m}$
Pitch		25 μrad	39 μrad	50 μrad	60 μrad
Roll		27 μrad	39 μrad	50 μrad	60 μrad
Yaw		27 μrad	39 μrad	50 μrad	60 μrad
Maximum Speed⁽²⁾		2 m/s			
Maximum Acceleration⁽²⁾		3 g			
Maximum Force, Continuous		153 N – Standard 251.6 N – With Air Cooling (20 psig)			
Load Capacity⁽³⁾	Horizontal	100 kg			
	Side	100 kg			
Moving Mass		8.4 kg			
Stage Mass		23.8 kg	26.9 kg	30.1 kg	33.3 kg
Material		Anodized Aluminum			
MTBF (Mean Time Between Failure)		20,000 Hours			

Notes:

1. Certified with -PL1/-PL2 option.
2. Requires the selection of an appropriate amplifier with sufficient voltage and current.
3. Axis-orientation for on-axis loading is listed.
4. Specifications are for single-axis systems measured 25 mm above the tabletop. Performance of multi-axis systems is payload and workpoint dependent. Contact factory for multi-axis applications.



PRO225LM SPECIFICATIONS

Mechanical Specifications		PRO225LM			
Travel		500	600	800	1000
Accuracy ⁽¹⁾	Standard	±14 µm	±15.5 µm	±17 µm	±18 µm
	Calibrated	±1 µm	±1 µm	±1.5 µm	±1.5 µm
Resolution (Min. Incremental Motion) ⁽²⁾		5 nm (-E1 Encoder)			
Bidirectional Repeatability ⁽¹⁾		±0.4 µm	±0.4 µm	±0.5 µm	±0.5 µm
Straightness ⁽¹⁾		±5.5 µm	±6.5 µm	±8 µm	±9.5 µm
Flatness ⁽¹⁾		±5.5 µm	±6.5 µm	±8 µm	±9.5 µm
Pitch		70 µrad	80 µrad	90 µrad	110 µrad
Roll		70 µrad	80 µrad	90 µrad	110 µrad
Yaw		70 µrad	80 µrad	90 µrad	110 µrad
Maximum Speed ⁽³⁾		2 m/s			
Maximum Acceleration ⁽³⁾		3 g			
Maximum Force, Continuous		153 N – Standard 251.6 N – With Air Cooling (20 psig)			
Load Capacity ⁽⁴⁾	Horizontal	100 kg			
	Side	100 kg			
Moving Mass		8.4 kg			
Stage Mass		36.5 kg	39.7 kg	46.1 kg	52.5 kg
Material		Anodized Aluminum			
MTBF (Mean Time Between Failure)		20,000 Hours			

Notes:

1. Certified with -PL1/-PL2 option.
2. Requires the selection of an appropriate amplifier with sufficient voltage and current.
3. Axis-orientation for on-axis loading is listed.
4. Specifications are for single-axis systems measured 25 mm above the tabletop. Performance of multi-axis systems is payload and workpoint dependent. Contact factory for multi-axis applications.

Electrical Specifications	
Drive System	Brushless Linear Servomotor
Feedback	Non-contact Linear Encoder -E1: 1 Vpp, 20 µm signal period -E2: Digital RS422, 0.1 µm electrical resolution
Maximum Bus Voltage	340 VDC
Limit Switches	5 V, Normally-Closed
Home Switch	Near Center

PRO225LM ORDERING OPTIONS

Travel (Required)

- 0100 100 mm travel stage
- 0200 200 mm travel stage
- 0300 300 mm travel stage
- 0400 400 mm travel stage
- 0500 500 mm travel stage
- 0600 600 mm travel stage
- 0800 800 mm travel stage
- 1000 1000 mm travel stage

Other travel options are available upon request. Contact Aerotech for more information.

Tabletop (Required)

- TT1 Tabletop with metric dimension mounting

NOTE: -TT1 option required for lower axis of XY.

Other tabletop options are available upon request. Contact Aerotech for more information.

Feedback (Required)

- E1 Incremental linear encoder, 1 Vpp
- E2 Incremental linear encoder, 0.1 μ m digital TTL output

Other feedback options are available upon request. Contact Aerotech for more information.

Cable Management (Required)

- CMS0 No external CMS, motor/feedback connector bracket on carriage
- CMS1 External CMS for single axis
- CMS2 External CMS for lower-axis of two-axis PRO (XY) assembly
- CMS3 External CMS for lower-axis of two-axis (XZ or XT) assembly
- CMS4 External CMS for upper-axis of two-axis PRO (XY) assembly
- CMS5 External CMS for upper-axis of two-axis (YZ or YT) assembly
- CMS6 External CMS for lower-axis of three-axis (XYZ or XYT) assembly
- CMS7 External CMS for lower-axis of three-axis (XZT) assembly
- CMS8 External CMS for upper-axis of four-axis (XYZT) assembly
- CMS9 External CMS for lower-axis of four-axis (XYZT) assembly

Lifting Hardware (Optional)

- LF Lifting hardware

NOTE: Lifting option only available on travels 300 mm and greater. Lifting should never be ordered on the upper-axis of an XY set (only order on lower-axis).

ThermoComp (Optional)

- TCMP ThermoComp integrated thermal compensation, single or lower axis

PRO225LM ORDERING OPTIONS

Metrology (Required)

- PL0 No metrology performance plots
- PL1 Metrology, uncalibrated with performance plots
- PL2 Metrology, calibrated (HALAR) with performance plots

Integration (Required)

Aerotech offers both standard and custom integration services to help you get your system fully operational as quickly as possible. The following standard integration options are available for this system. Please consult Aerotech if you are unsure what level of integration is required or if you desire custom integration support with your system.

-TAS Integration - Test as system

Testing, integration and documentation of a group of components as a complete system that will be used together (ex: drive, controller and stage). This includes parameter file generation, system tuning and documentation of the system configuration.

-TAC Integration - Test as components

Testing and integration of individual items as discrete components. This is typically used for spare parts, replacement parts or items that will not be used or shipped together (ex: stage only). These components may or may not be part of a larger system.

Accessories (To Be Ordered As Separate Line Item)

- ALIGN-NPA** Non-precision XY assembly
- ALIGN-NPAZ** Non-precision XZ or YZ assembly
- ALIGN-PA10** XY assembly; 10 arc sec orthogonality. Alignment to within 7 microns orthogonality for short travel stages.
- ALIGN-PA10Z** XZ or YZ assembly with L-bracket; 10 arc second orthogonality. Alignment to within 10 microns orthogonality for short travel stages.
- ALIGN-PA5** XY assembly; 5 arc sec orthogonality. Alignment to within 3 microns orthogonality for short travel stages.
- ALIGN-PA5Z** XZ or YZ assembly with L-bracket; 5 arc second orthogonality. Alignment to within 5 microns orthogonality for short travel stages.



PRO225LM SPECIFICATIONS

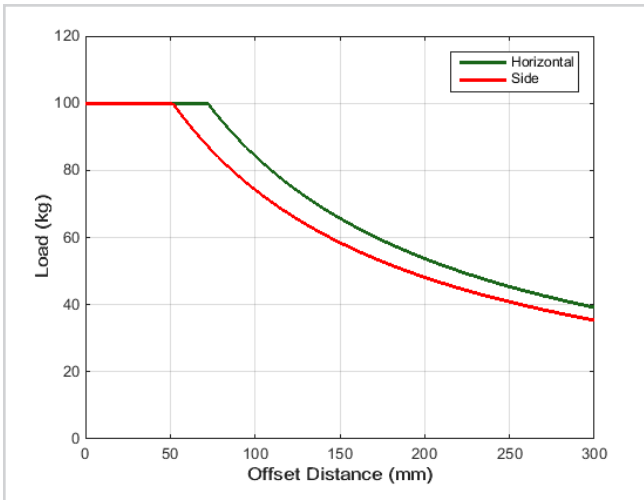

Cantilevered load capability of the PRO225LM.

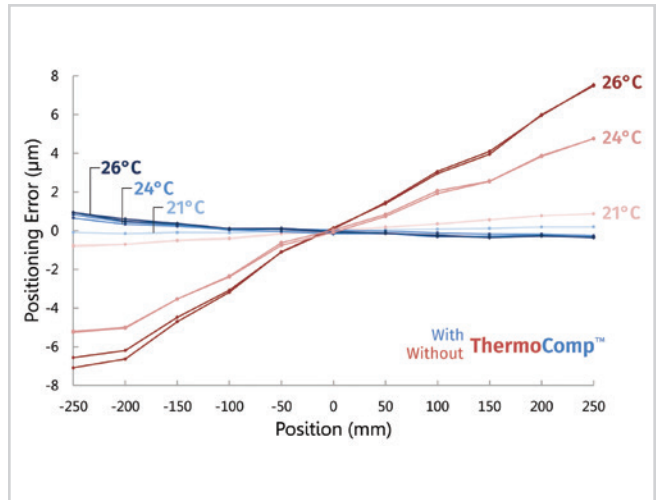

Measurement data showing successful compensation of thermal related positioning errors at several temperatures using the ThermoComp feature. Results are typical of stage performance with and without ThermoComp.

PRO225LM DIMENSIONS

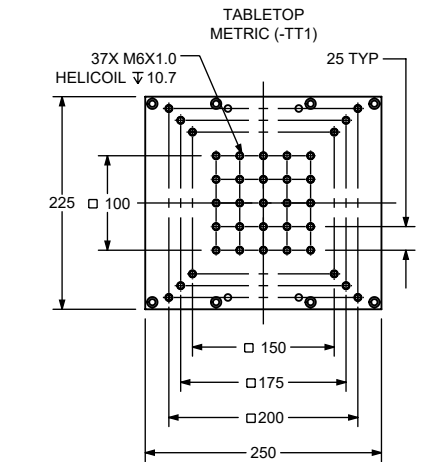
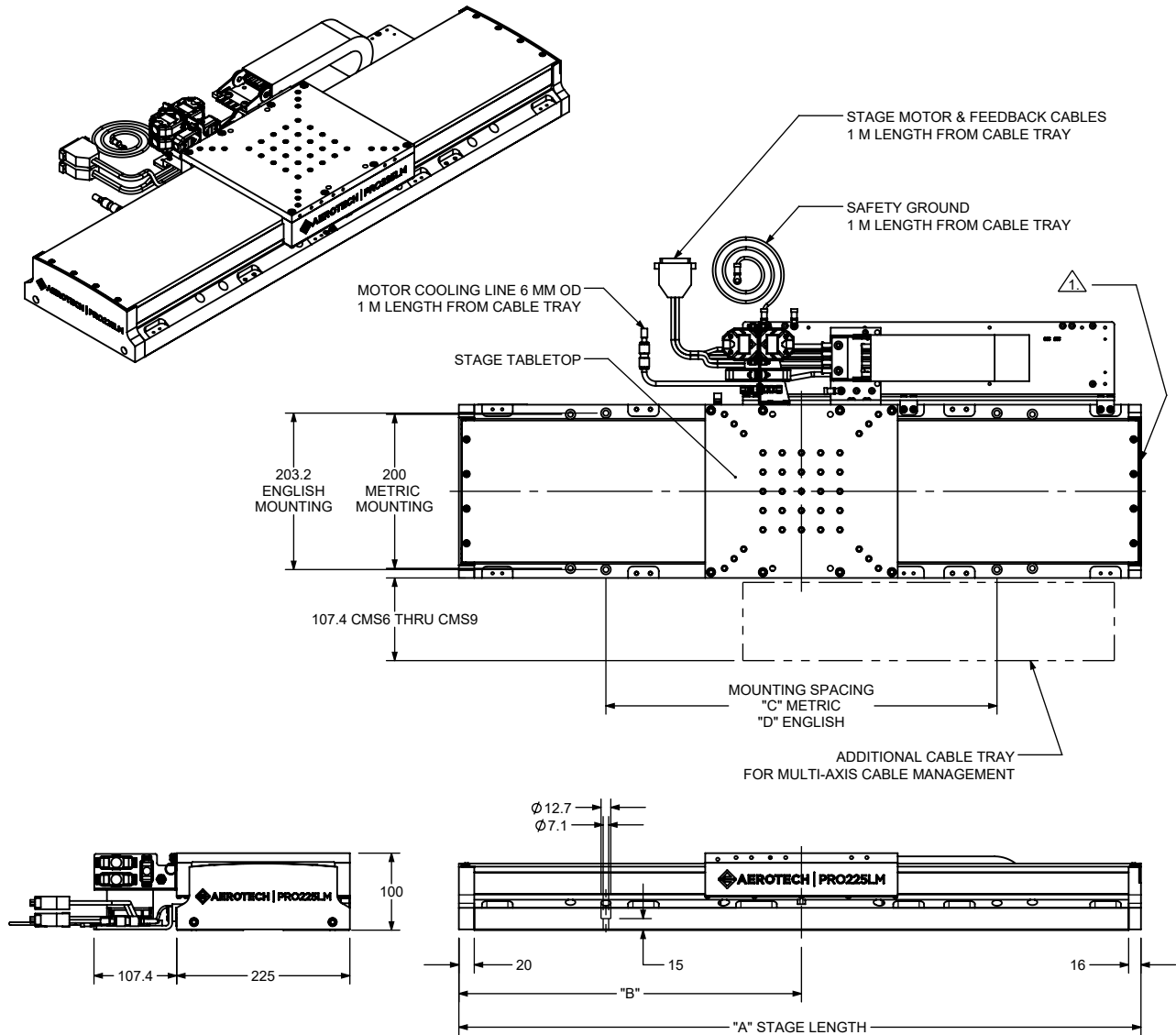

BASIC MODEL	NOMINAL TRAVEL	ELEC LIMIT TRAVEL	MECH LIMIT TRAVEL	A	B	C	D
PRO225LM-0100	100	102-108	129.4	486	245	200, 350	203.2
PRO225LM-0200	200	202-208	229.4	586	295	200, 350	203.2
PRO225LM-0300	300	302-308	329.4	686	345	200, 600	203.2
PRO225LM-0400	400	402-408	429.4	786	395	200, 600	203.2, 508
PRO225LM-0500	500	502-508	529.4	886	445	200, 600	203.2, 508
PRO225LM-0600	600	602-608	629.4	986	495	200, 600	203.2, 508
PRO225LM-0800	800	802-808	829.4	1186	595	200, 600, 1000	203.2, 711.2
PRO225LM-1000	1000	1002-1008	1029.4	1386	695	200, 600, 1000	203.2, 711.2, 990.6

NOTES:

1. M5X0.8 FOR CUSTOMER-INSTALLED AIR PURGE FITTING.

2. DIMENSIONS: MILLIMETERS.

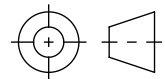

PRO225LM SERIES CABLE MANAGEMENT (-CMS0) DIMENSIONS

PRO115LM/PRO165LM -CMS0

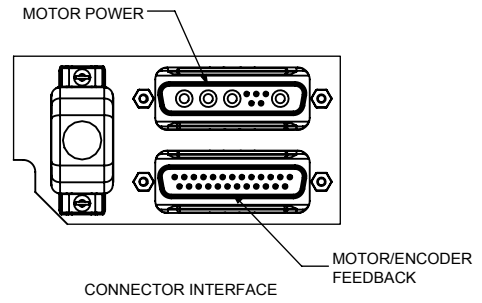
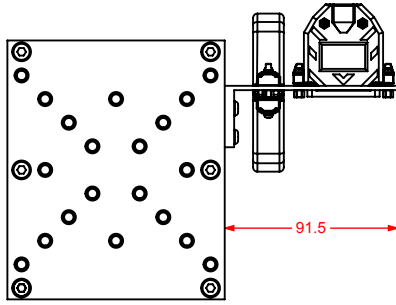

PRO190LM -CMS0

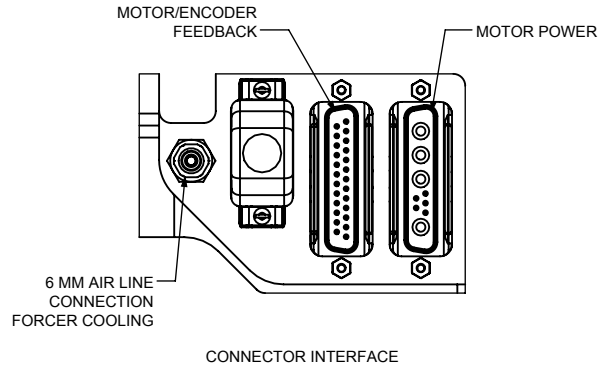
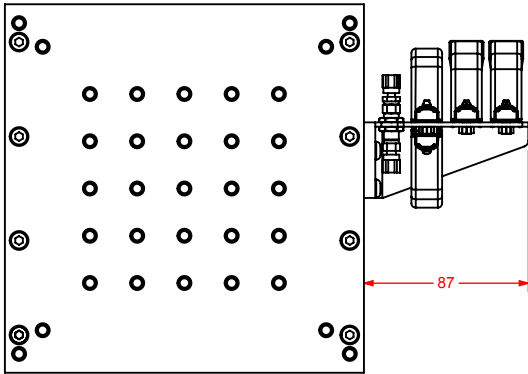

PRO225LM/PRO280LM/PRO560LM -CMS0

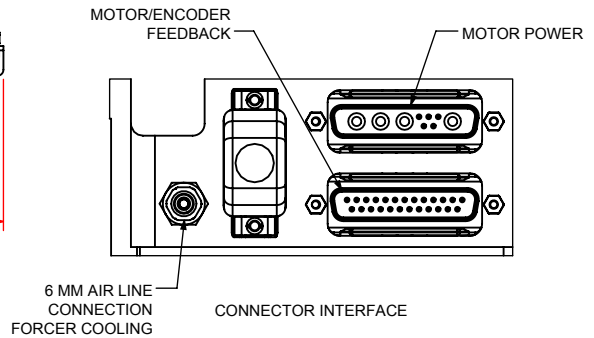
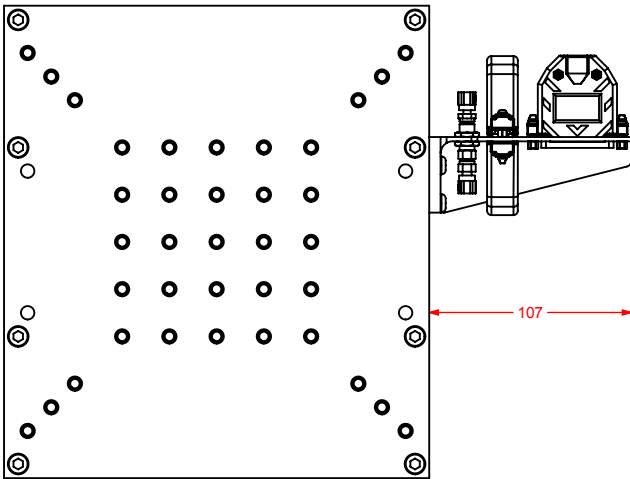

DIMENSIONS: MILLIMETERS