

LINEAR STAGES **PLANAR_{DL} SERIES**

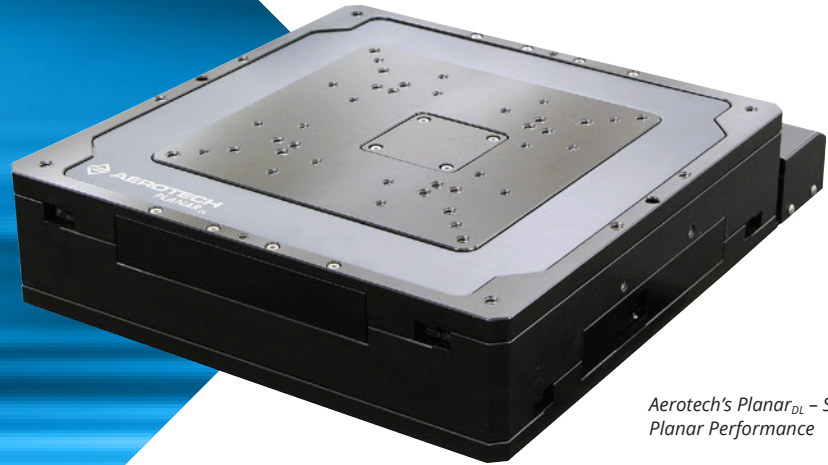

Aerotech's Planar_{DL} – Superior Planar Performance

Aerotech's Planar_{DL}-series stages offer excellent geometric and dynamic performance in a compact, low-profile package. A variety of travel and performance options make this stage ideal for applications ranging from surface profilometry to LED wafer scribing.

Superior Stage Design

The Planar_{DL} XY design allows for industry-leading planar geometric performance in applications where straightness and flatness of motion are critical. High-precision anti-creep crossed-roller bearings, precision-machined surfaces and Aerotech linear motors driving through the axes' center-of-stiffness result in a positioning stage with exceptional geometric tolerances.

The Planar_{DL} structural elements are optimized for high-dynamics and high-stiffness for the most demanding dynamic applications. Capable of achieving 1 m/s velocities and 1.5 g accelerations, the Planar_{DL} enables high-throughput, high-accuracy processing resulting in superior process yield and a low total cost of ownership. Unlike competitive products using recirculating bearings, the anti-creep crossed-roller bearings used in this design permit smooth motion making this an ideal stage solution for challenging scanning applications.

Noncontact Direct-Drive Technology

Only noncontact, direct-drive technology offers high-speed and accurate positioning coupled with maintenance-free operation and long service life. At the heart of the Planar_{DL} is Aerotech's proprietary direct-drive technology. This drive technology allows

for unmatched performance compared to other competitive screw-based and linear motor designs.

The Planar_{DL}-200XY and -300XY stages are both available with one or two motors per axis, allowing optimization of each individual axis for the specific application and process. Regardless of the number of motors selected, the resulting drive force acts through the centers of friction and stiffness resulting in superior geometric performance and accuracy.

Integrated Cable Management

The cable management system on the Planar_{DL} is integrated into the stage and optimized for long life and performance. Additional standard options are available for extra servo axes or air/vacuum lines for vacuum chucks or other process pneumatics.

Extreme Positioning Performance

The Planar_{DL} is available in three positioning performance options. Relying upon decades of experience in system-level design including not only positioning mechanics, but also software and electronics, Aerotech has developed advanced technologies to push the envelope of precision. High-performance -PLUS and -ULTRA options are available to enable accuracies and straightness values down to ± 400 nm and orthogonality down to 1 arc second.

— PRODUCT HIGHLIGHTS —

Integrated, low-profile, XY, linear-motor stage

Excellent geometric performance (straightness to ± 0.4 μm ; flatness to ± 1 μm)

Anti-creep, precision crossed-roller bearings

Large selection – nine models in travel and accuracy

Planar_{DL} Series Specifications

Mechanical Specifications	Planar _{DL} -100XY			Planar _{DL} -200XY			Planar _{DL} -300XY			
	-PL1	-PL3 ⁽¹⁾	-PL4 ⁽¹⁾	-PL1	-PL3 ⁽¹⁾	-PL4 ⁽¹⁾	-PL1	-PL3 ⁽¹⁾	-PL4 ⁽¹⁾	
Travel	100 mm x 100 mm			200 mm x 200 mm			300 mm x 300 mm			
Accuracy	±3 µm	±0.4 µm	±0.4 µm	±4 µm		±0.5 µm	±5 µm	±0.75 µm	±0.75 µm	
Bidirectional Repeatability⁽²⁾	±0.1 µm									
Resolution (Minimum Incremental Motion)	3 nm									
Straightness	±1 µm		±0.4 µm	±1.5 µm		±0.5 µm	±2 µm		±0.75 µm	
Flatness	±1 µm			±1.5 µm			±2 µm			
Pitch	12 arc sec			15 arc sec			18 arc sec			
Roll	12 arc sec			15 arc sec			18 arc sec			
Yaw	6 arc sec			8 arc sec			10 arc sec			
Orthogonality	20 arc sec	5 arc sec	1 arc sec	20 arc sec	5 arc sec	1 arc sec	20 arc sec	5 arc sec	1 arc sec	
Maximum Speed	500 mm/s			750 mm/s			1000 mm/s			
Maximum Acceleration (No Load; Upper Axis)	1.5 g			1.0 g (x1 Motor) 1.5 g (x2 Motors)			1.0 g (x1 Motor) 1.5 g (x2 Motors)			
Maximum Force (Continuous)	26 N			31 N (x1 Motor) 62 N (x2 Motors)			78 N (x1 Motor) 156 N (x2 Motors)			
Load Capacity⁽³⁾	Horizontal	15 kg			20 kg			30 kg		
Moving Mass	Upper Axis	2.9 kg			6.3 kg (-M1 or -M3 Motor) 7.4 kg (-M2 or -M4 Motor)			16.3 kg (-M1 or -M3 Motor) 19.1 kg (-M2 or -M4 Motor)		
	Lower Axis	8.4 kg			16.8 kg (-M1 Motor) 17.8 kg (-M2 or -M3 Motor) 19.0 kg (-M4 Motors)			45.0 kg (-M1 Motor) 48.1 kg (-M2 or -M3 Motor) 50.9 kg (-M4 Motors)		
Stage Mass⁽⁴⁾	11 kg			23-25 kg			53-63 kg			
Material	Black Anodized Aluminum									
MTBF (Mean Time Between Failure)	30,000 Hours									

Notes:

1. The -PL3 and -PL4 options require the use of an Aerotech controller.
2. Repeatability specification assumes a feedback resolution of 20 nm or less.
3. On-axis loading for orientation listed.
4. Stage mass is a function of motor configuration.
5. Specifications for -PL1 and -PL3 options are per axis measured 25 mm above the tabletop. Specifications for -PL4 are XY measured 25 mm above the tabletop.



Planar_{DL}-200XY with -CMS2 option.

Planar_{DL} Series Specifications

Electrical Specifications	Planar _{DL} -100XY	Planar _{DL} -200XY	Planar _{DL} -300XY
Drive System	Brushless Linear Servomotor		
Feedback	Noncontact Linear Encoder		
Maximum Bus Voltage	340 VDC		
Limit Switches	5 V, Normally Closed		
Home Switch	Near Center of XY Travel		

Recommended Controller	Planar _{DL} -100XY	Planar _{DL} -200XY	Planar _{DL} -300XY
Multi-Axis	A3200	Ndrive CP, Ndrive HLe/HPe, Npaq	
	Ensemble	Ensemble CP, Ensemble HLe/HPe	
Single Axis	Soloist	Soloist CP, Soloist HLe/HPe	

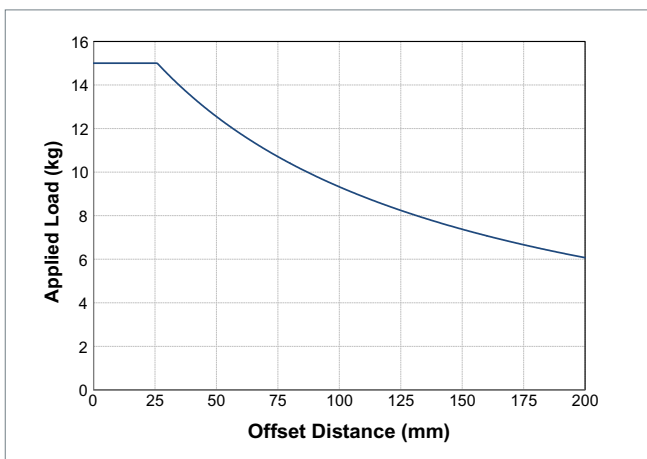

Planar_{DL}-100XY applied load versus offset distance.

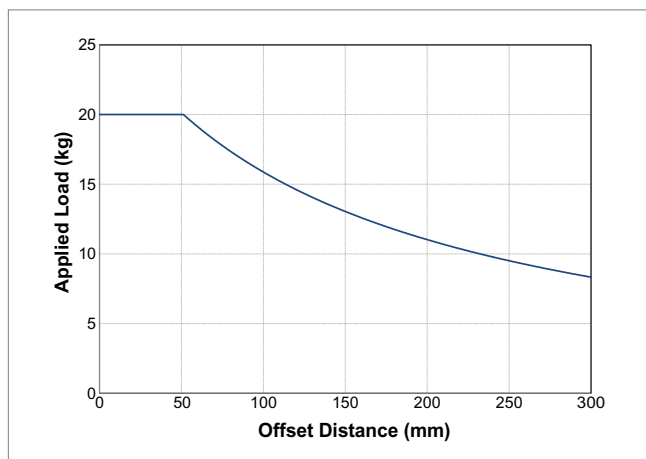

Planar_{DL}-200XY applied load versus offset distance.

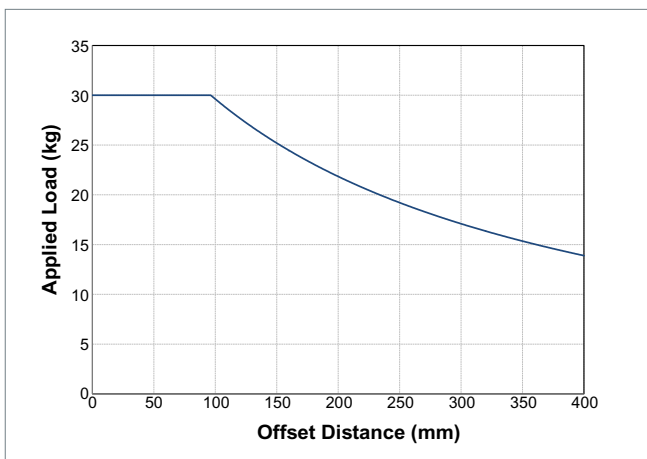

Planar_{DL}-300XY applied load versus offset distance.

Planar_{DL}-100XY Dimensions

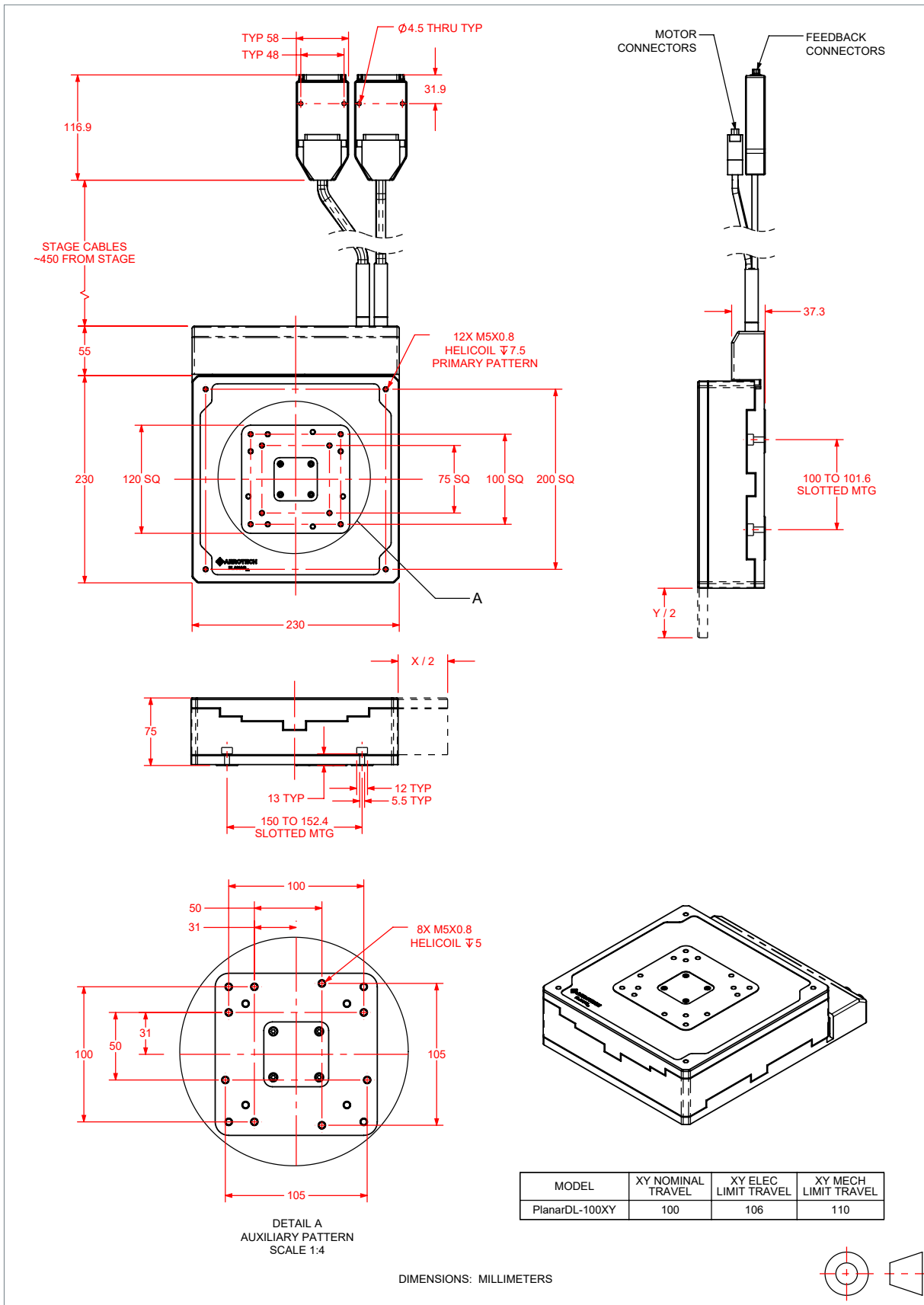

MODEL	XY NOMINAL TRAVEL	XY ELEC LIMIT TRAVEL	XY MECH LIMIT TRAVEL
PlanarDL-100XY	100	106	110

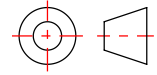

Planar_{DL}-100XY-CMS1/2 Dimensions

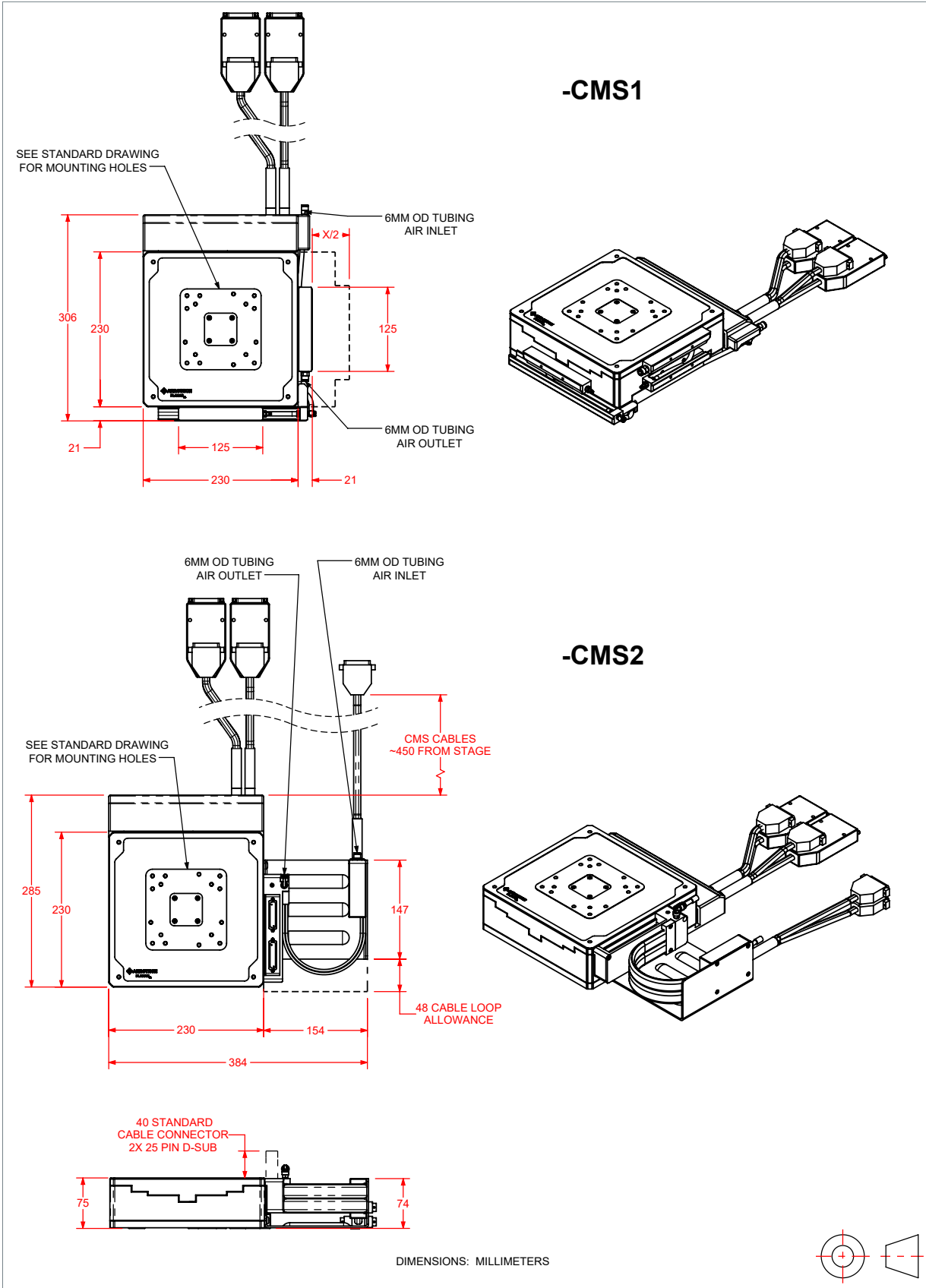

Planar_{DL}-200XY Dimensions

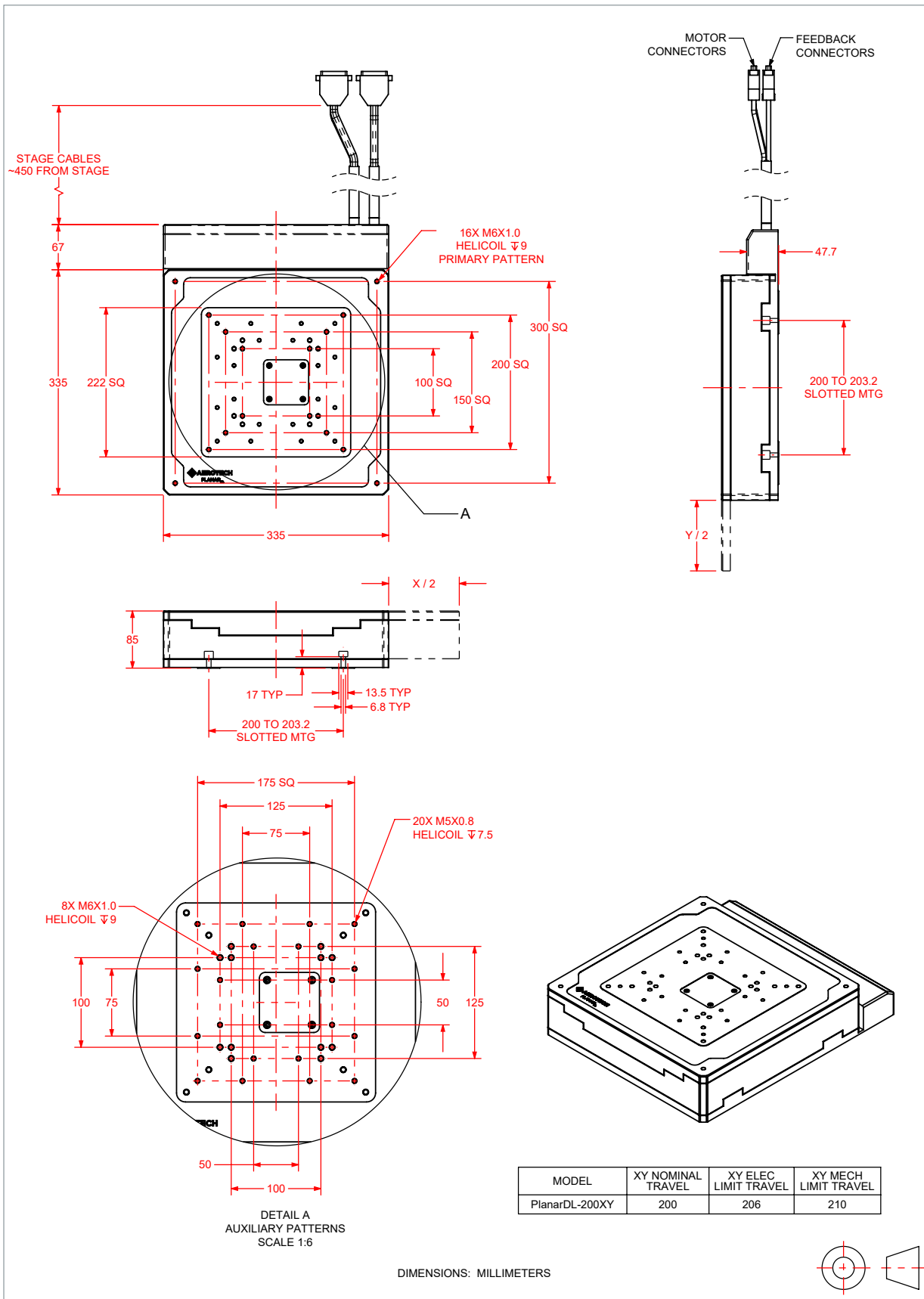

Planar_{DL}-200XY-CMS1/2 Dimensions

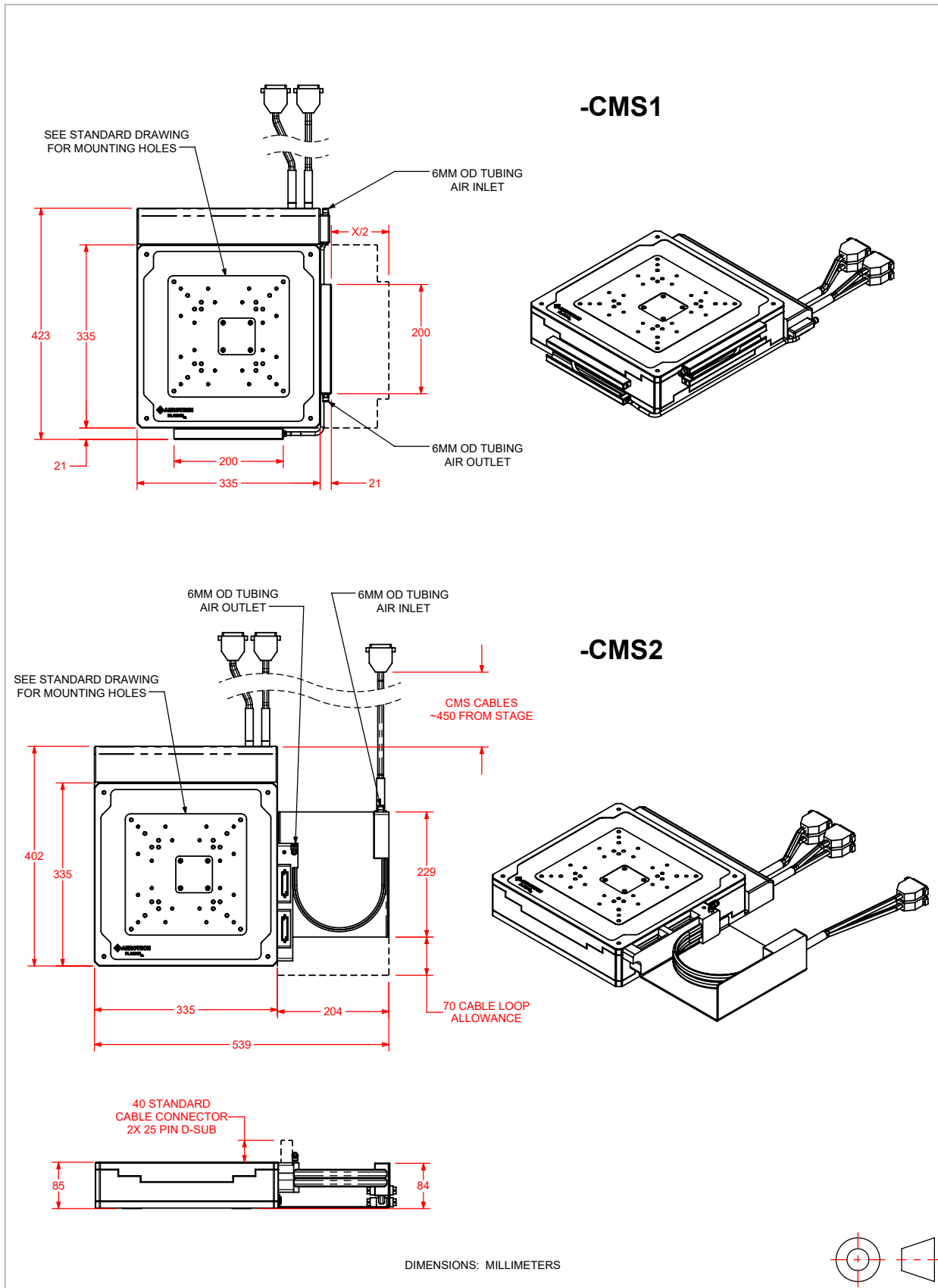

Planar_{DL}-300XY Dimensions

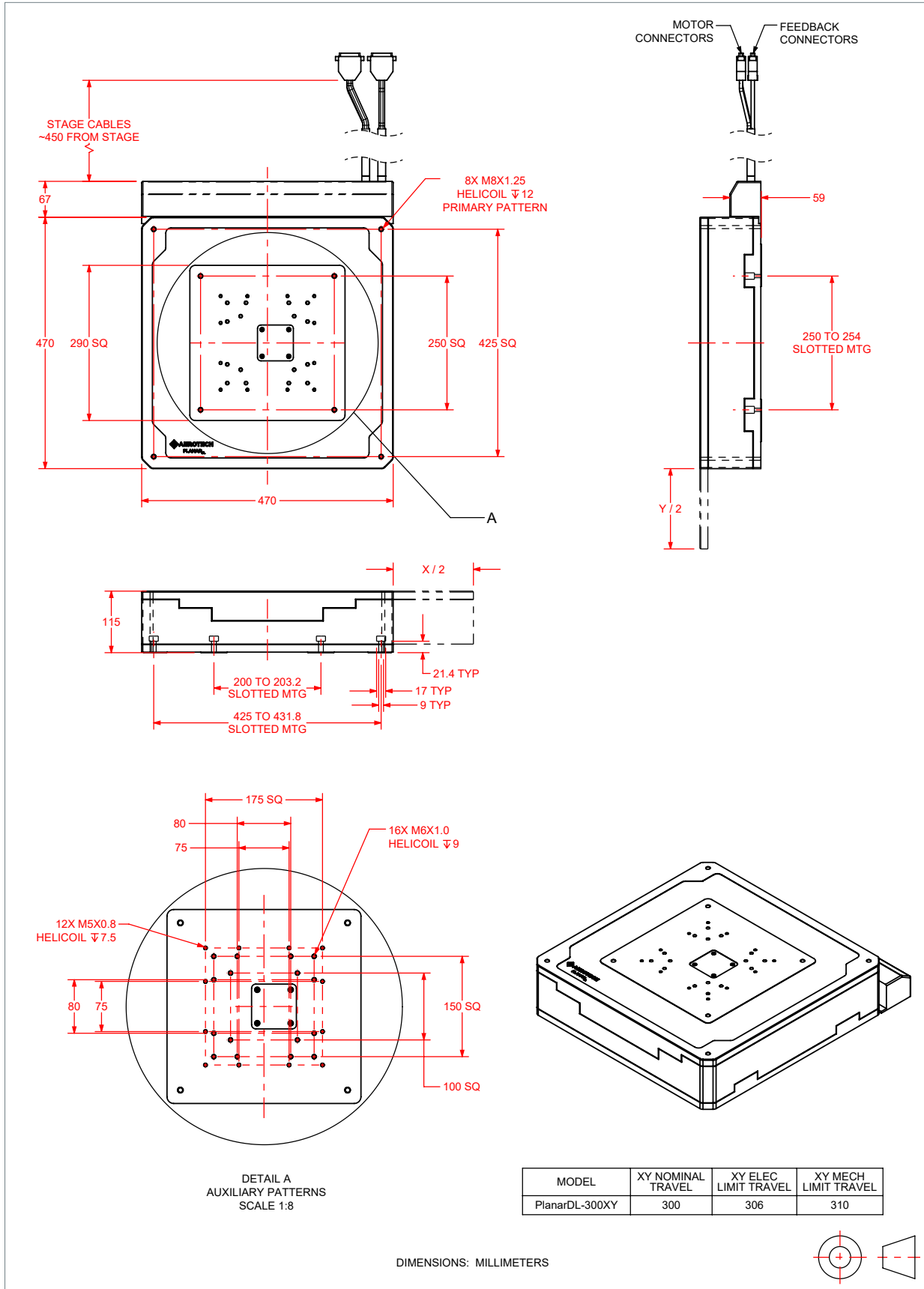

Planar_{DL}-300XY-CMS1/2 Dimensions

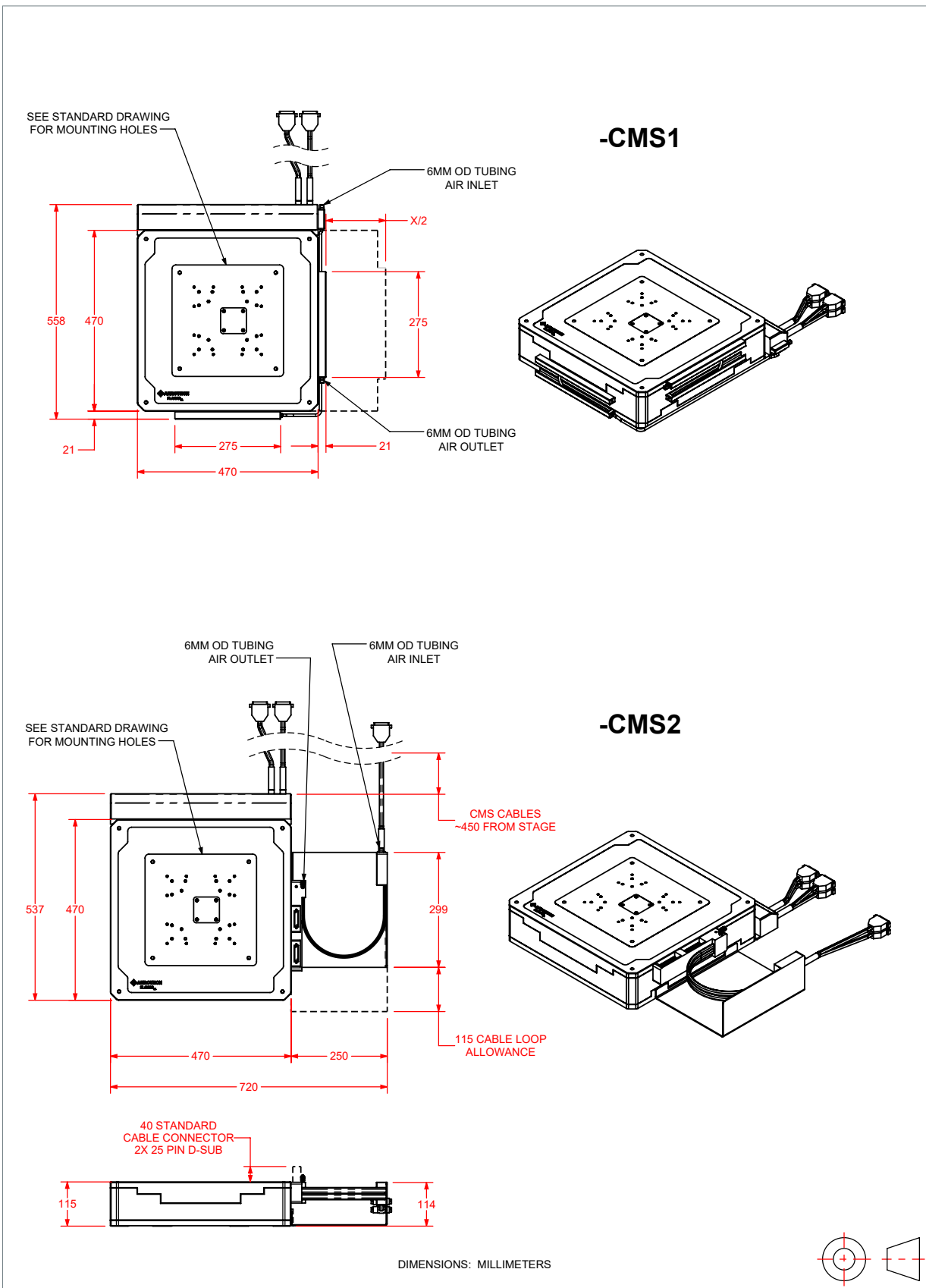

Planar_{DL} Series **Ordering Information**

Planar_{DL} Two Axis Mechanical-Bearing Direct-Drive Linear Stage

Planar _{DL} -100XY	Two axis mechanical-bearing direct-drive linear stage, 100 x 100 mm travel
Planar _{DL} -200XY	Two axis mechanical-bearing direct-drive linear stage, 200 x 200 mm travel
Planar _{DL} -300XY	Two axis mechanical-bearing direct-drive linear stage, 300 x 300 mm travel

Motor (Required) - Not Applicable for Planar_{DL}-100XY

-M1	1 motor on upper axis; 1 motor on lower axis
-M2	2 motors on upper axis; 1 motor on lower axis
-M3	1 motor on upper axis; 2 motors on lower axis
-M4	2 motors on upper axis; 2 motors on lower axis

Feedback (Required)

-E1	Incremental encoders, 1 Vpp on upper and lower axes
-E2	Incremental encoders, 0.1 μm Digital RS422 on upper axis, 1 Vpp on lower axis
-E3	Incremental encoders, 1 Vpp on upper axis, 0.1 μm Digital RS422 on lower axis
-E4	Incremental encoders, 0.1 μm Digital RS422 on upper and lower axes

Cable Management (Optional)

-CMS1	Cable management for air/vacuum line
-CMS2	Cable management for air/vacuum line and 3rd axis motor/feedback

Performance Grade (Required)

-PL1	Base performance
-PL3	High-accuracy performance, PLUS
-PL4	Ultra-high accuracy 2D performance, ULTRA

Note: -PL3 and -PL4 performance grades require Aerotech controller.

Integration (Required)

Aerotech offers both standard and custom integration services to help you get your system fully operational as quickly as possible. The following standard integration options are available for this system. Please consult Aerotech if you are unsure what level of integration is required, or if you desire custom integration support with your system.

-TAS	Integration - Test as system Testing, integration, and documentation of a group of components as a complete system that will be used together (ex: drive, controller, and stage). This includes parameter file generation, system tuning, and documentation of the system configuration.
-TAC	Integration - Test as components Testing and integration of individual items as discrete components that ship together. This is typically used for spare parts, replacement parts, or items that will not be used together. These components may or may not be part of a larger system.