

# Planar<sub>DLA</sub> Series

## Two Axis Mechanical-Bearing Direct Drive Stage with Aperture

Integrated, low-profile, XY, linear-motor stage with clear aperture

Excellent geometric performance (straightness to  $\pm 0.5 \mu\text{m}$ , flatness to  $\pm 1.25 \mu\text{m}$ )

Optimized for high-dynamic applications

Speeds to 2.0 m/s and accelerations to 2 g

Integrated cable management

Large selection – nine models in travel and accuracy



*The Planar<sub>DLA</sub> structural elements are optimized for high dynamics and high stiffness for the most demanding dynamic applications.*

Aerotech's Planar<sub>DLA</sub>-series stages offer a clear aperture, high dynamics, and exceptional geometric performance in a compact, low-profile package. These stages are essential for applications ranging from two-sided LED wafer processing where high-dynamics and micrometer-level straightness are required, to quasi-static optical metrology where high-accuracy and precise geometric performance are necessary. Regardless of the application, the Planar<sub>DLA</sub> is designed to meet a variety of application needs with an array of configurable options.

### Ultra-Precise Stage Design

The Planar<sub>DLA</sub> XY design provides for unparalleled planar geometric performance in applications where straightness and flatness of motion are critical. High-precision roller bearings, precision-machined surfaces, and noncontact direct-drive linear motors driving through the axes' center-of-stiffness result in a positioning stage with exceptional geometric tolerances (straightness to  $\pm 0.5 \mu\text{m}$  and flatness to  $\pm 1.25 \mu\text{m}$ ).

The Planar<sub>DLA</sub> structural elements are optimized for high dynamics and high stiffness for the most demanding dynamic applications. With this optimized design, the Planar<sub>DLA</sub> achieves high servo bandwidths while at the same time maximizing the clear aperture available and keeping the overall height to a minimum. Capable of achieving 2.0 m/s velocities and 2 g accelerations, the Planar<sub>DLA</sub> enables high-throughput, high-accuracy processing resulting in superior process yield, and a low total cost of ownership.

### Noncontact Direct-Drive Technology

Only noncontact, direct-drive technology offers high speed and accurate positioning coupled with maintenance-free operation and long service life. At the heart of the Planar<sub>DLA</sub> is Aerotech's proprietary direct-drive technology. This drive technology allows for unmatched performance compared to other competitive screw-based and linear motor designs.

All Planar<sub>DLA</sub> stages are available with one or two motors per axis allowing optimization of each individual axis for the specific application and process. With two motors, the resulting drive force acts through the centers of friction and stiffness resulting in superior geometric performance and accuracy, while one motor per axis provides for a more economical choice if high-throughput and the strictest positioning performance is not required.

### Variety of Cable Management Options

The standard cable management system on the Planar<sub>DLA</sub> is integrated into the stage and optimized for long life and performance. Several standard options are available for additional servo axes, air/vacuum lines for vacuum chucks, or other process pneumatics.

### Extreme Positioning Performance

The Planar<sub>DLA</sub> is available in three positioning performance options. Relying on decades of experience in system-level design including not only positioning mechanics, but also software and electronics, Aerotech has developed advanced technologies to push the envelope of precision. High-performance -PLUS and -ULTRA options are available to enable accuracies and straightness values down to  $\pm 500 \text{ nm}$  and orthogonality down to  $5 \mu\text{rad}$ .

# Planar<sub>DLA</sub> Series SPECIFICATIONS

Mechanical Specifications		Planar <sub>DLA</sub> -150XY			Planar <sub>DLA</sub> -250XY			Planar <sub>DLA</sub> -330XY			
		-PL1	-PL3 <sub>(1,2)</sub>	-PL4 <sub>(1,2)</sub>	-PL1	-PL3 <sub>(1,2)</sub>	-PL4 <sub>(1,2)</sub>	-PL1	-PL3 <sub>(1,2)</sub>	-PL4 <sub>(1,2)</sub>	
Travel		150 mm x 150 mm			250 mm x 250 mm			330 mm x 330 mm			
Accuracy <sup>(2)</sup>	Single Motor	±5 µm	±0.7 µm	±0.7 µm	±6 µm	±0.8 µm	±0.8 µm	±8 µm	±1 µm	±1 µm	
	Dual Motors	±4 µm	±0.4 µm	±0.4 µm	±5 µm	±0.5 µm	±0.5 µm	±6 µm	±0.7 µm	±0.7 µm	
Bidirectional Repeatability	Single Motor	±0.5 µm			±0.5 µm			±0.5 µm			
	Dual Motors	±0.25 µm			±0.25 µm			±0.25 µm			
Resolution (Minimum Incremental Motion) <sup>(3)</sup>		3 nm			3 nm			3 nm			
Straightness	Upper Axis	-M1 or -M3 Motor	±1.5 µm	±1.5 µm	±0.7 µm	±2.0 µm	±2.0 µm	±0.7 µm	±2.5 µm	±2.5 µm	±0.8 µm
		-M2 or -M4 Motor	±1.0 µm	±1.0 µm	±0.5 µm	±1.5 µm	±1.5 µm	±0.5 µm	±2.0 µm	±2.0 µm	±0.6 µm
	Lower Axis	-M1 or -M2 Motor	±2.5 µm	±2.5 µm	±0.7 µm	±3.25 µm	±3.25 µm	±0.7 µm	±4.0 µm	±4.0 µm	±0.8 µm
		-M3 or -M4 Motor	±2.0 µm	±2.0 µm	±0.5 µm	±2.75 µm	±2.75 µm	±0.5 µm	±3.5 µm	±3.5 µm	±0.6 µm
Flatness		±1.25 µm			±1.75 µm			±2.5 µm			
Pitch		39 µrad (8 arc sec)			58 µrad (12 arc sec)			68 µrad (14 arc sec)			
Roll		39 µrad (8 arc sec)			58 µrad (12 arc sec)			68 µrad (14 arc sec)			
Yaw	Single Motor	39 µrad (8 arc sec)			49 µrad (10 arc sec)			58 µrad (12 arc sec)			
	Dual Motors	29 µrad (6 arc sec)			39 µrad (8 arc sec)			49 µrad (10 arc sec)			
Orthogonality		97 µrad (20 arc sec)	24 µrad (5 arc sec)	5 µrad (1 arc sec)	97 µrad (20 arc sec)	24 µrad (5 arc sec)	5 µrad (1 arc sec)	97 µrad (20 arc sec)	24 µrad (5 arc sec)	5 µrad (1 arc sec)	
Max Speed <sup>(4)</sup>		1.5 m/s			2.0 m/s			2.0 m/s			
Max Acceleration (No Load, Upper-Axis) <sup>(4)</sup>		1.0 g (-M1 or -M3 Motor) 2.0 g (-M2 or -M4 Motor)			1.0 g (-M1 or -M3 Motor) 2.0 g (-M2 or -M4 Motor)			1.0 g (-M1 or -M3 Motor) 2.0 g (-M2 or -M4 Motor)			
Maximum Force - Continuous, 1.4 bar (20 psi) air cooling	Upper Axis	47 N (-M1 or -M3 Motor) 94 N (-M2 or -M4 Motor)			120 N (-M1 or -M3 Motor) 240 N (-M2 or -M4 Motor)			173 N (-M1 or -M3 Motor) 346 N (-M2 or -M4 Motor)			
	Lower Axis	120 N (-M1 or -M2 Motor) 240 N (-M3 or -M4 Motor)			250 N (-M1 or -M2 Motor) 500 N (-M3 or -M4 Motor)			302 N (-M1 or -M2 Motor) 604 N (-M3 or -M4 Motor)			
Load Capacity <sup>(5)</sup>		Horizontal 20 kg			30 kg			50 kg			
Moving Mass	Upper Axis	4.3 kg (-M1 or -M3 Motor) 4.5 kg (-M2 or -M4 Motor)			6.9 kg (-M1 or -M3 Motor) 7.2 kg (-M2 or -M4 Motor)			13.4 kg (-M1 or -M3 Motor) 14.0 kg (-M2 or -M4 Motor)			
	Lower Axis	18.1 kg (-M1 motor) 20.0 kg (-M2 motor) 18.5 kg (-M3 motor) 20.6 kg (-M4 motor)			33.7 kg (-M1 motor) 38.1 kg (-M2 motor) 34.6 kg (-M3 motor) 39.0 kg (-M4 motor)			57.0 kg (-M1 motor) 65.3 kg (-M2 motor) 58.1 kg (-M3 motor) 66.5 kg (-M4 motor)			
Stage Mass <sup>(6)</sup>		30 kg-36 kg			60 kg-67 kg			93 kg-109 kg			
Material		Black Anodized Aluminum									
MTBF (Mean Time Between Failure)		30,000 Hours									

**Notes:**

- The -PL3 and -PL4 options require the use of an Aerotech controller.
- Specifications for -PL1 and -PL3 options are per axis measured 25 mm above the tabletop. Specifications for -PL4 are XY measured 25 mm above the tabletop.
- Specified for dual motors. Contact factory for single motor arrangement.
- Requires the selection of an appropriate amplifier with sufficient voltage and current.
- On-axis loading for orientation listed.
- Stage mass is a function of motor configuration.

Electrical Specifications	Planar <sub>DLA</sub>
Drive System	Brushless Linear Servomotor
Feedback	Noncontact Linear Encoder
Maximum Bus Voltage	340 VDC
Limit Switches	5 V, Normally-Closed
Home Switch	Near Center of XY travel

Recommended Controller		Planar <sub>DLA</sub>
Multi-Axis	A3200	Ndrive CP Ndrive HLe/HPe Npaq
	Ensemble	Ensemble CP Ensemble HLe/HPe

**Planar<sub>DLA</sub> Series PERFORMANCE**

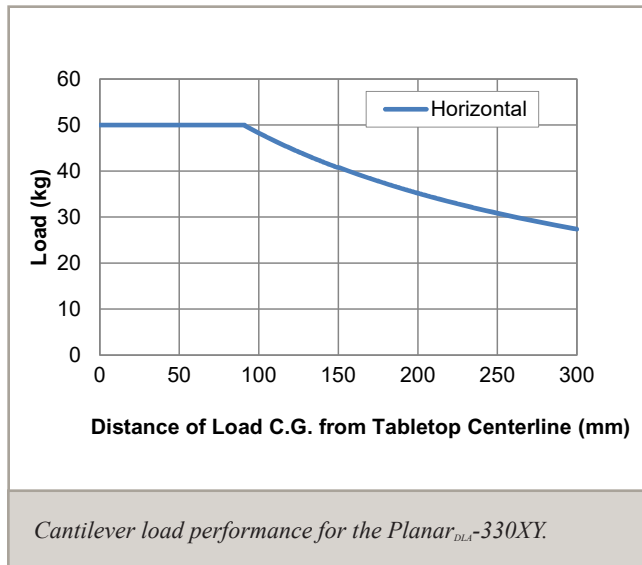
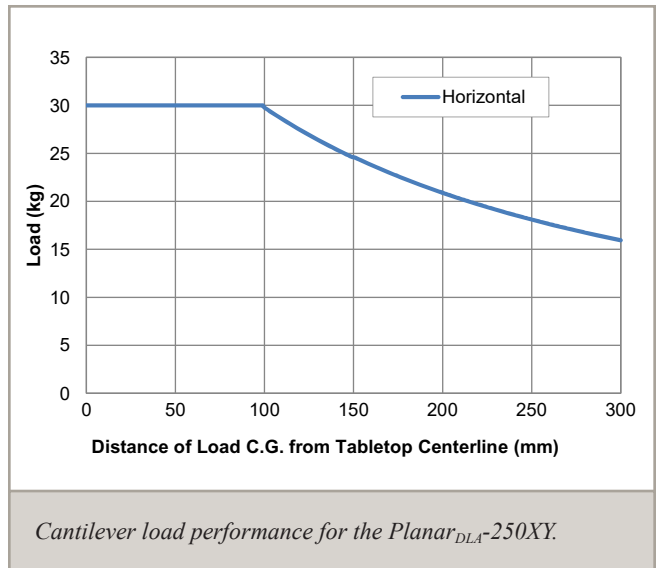
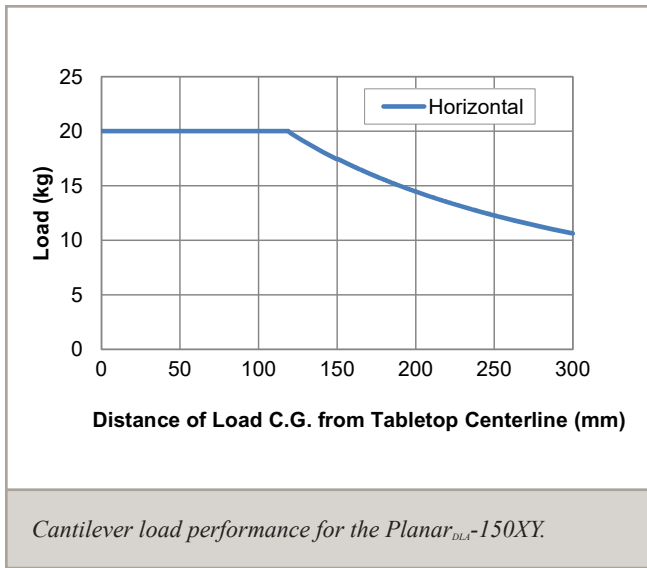

## Planar<sub>DLA</sub>-150XY DIMENSIONS

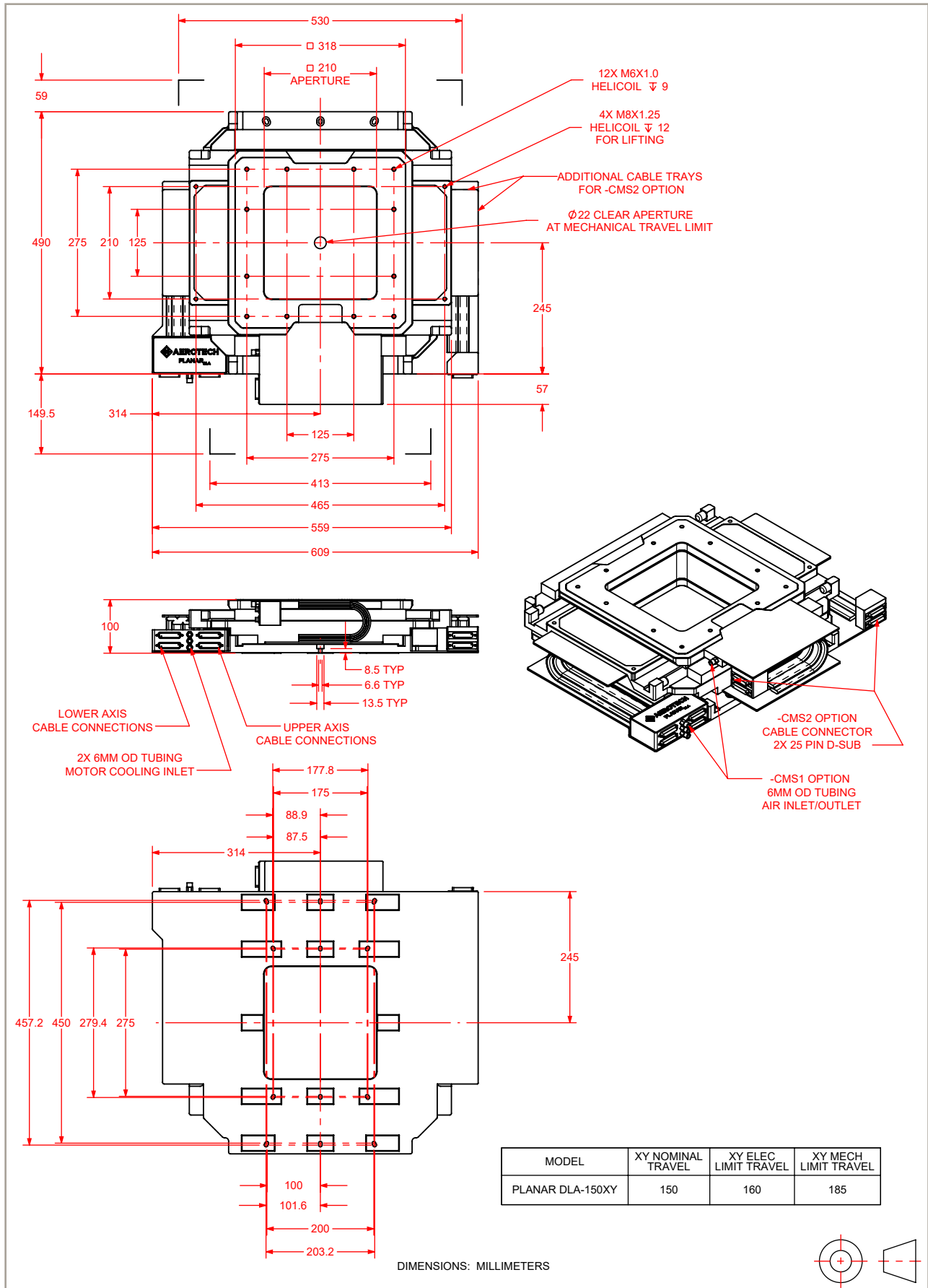

# Planar<sub>DLA</sub>-250XY DIMENSIONS

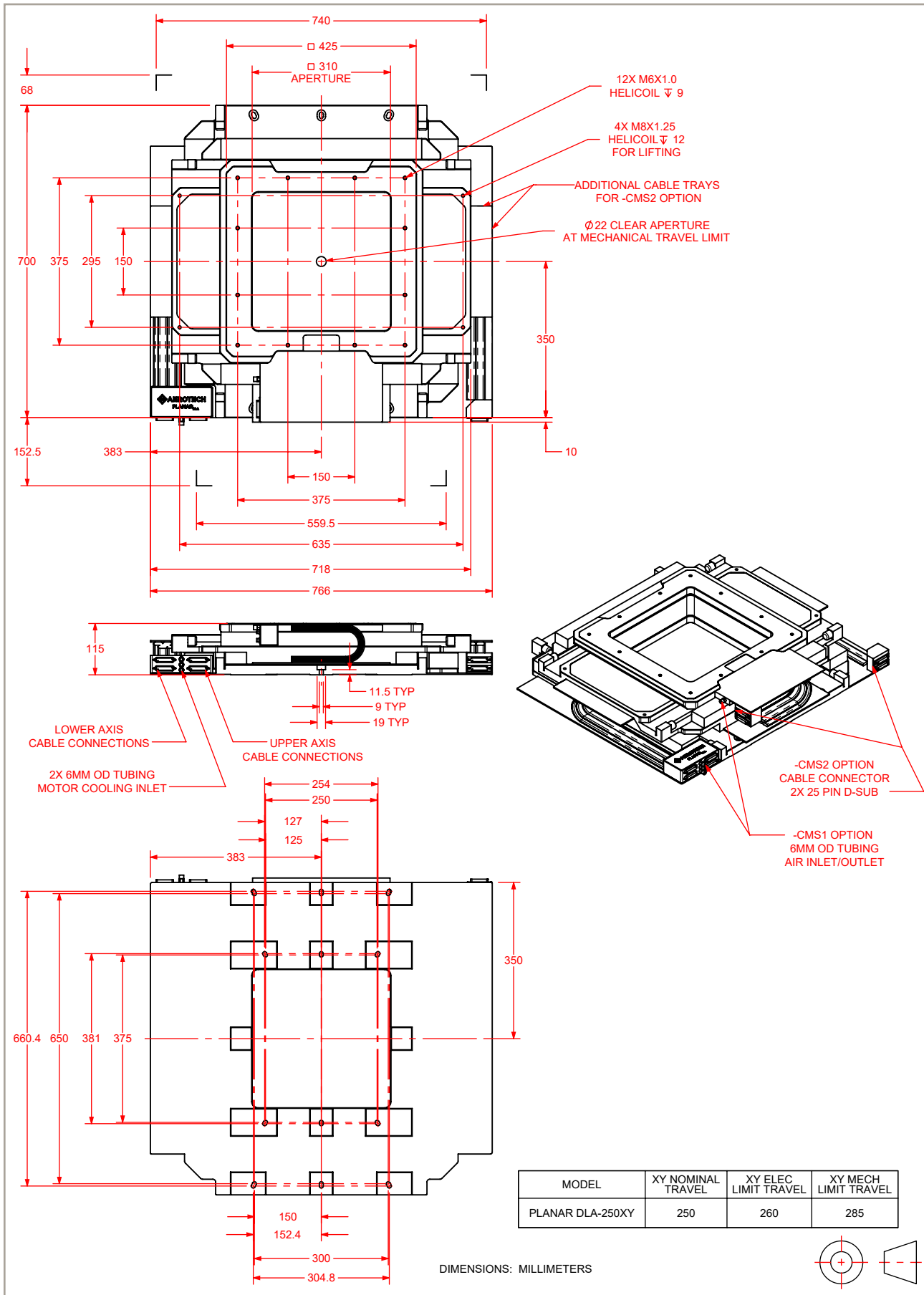

## Planar<sub>DLA</sub>-330XY DIMENSIONS

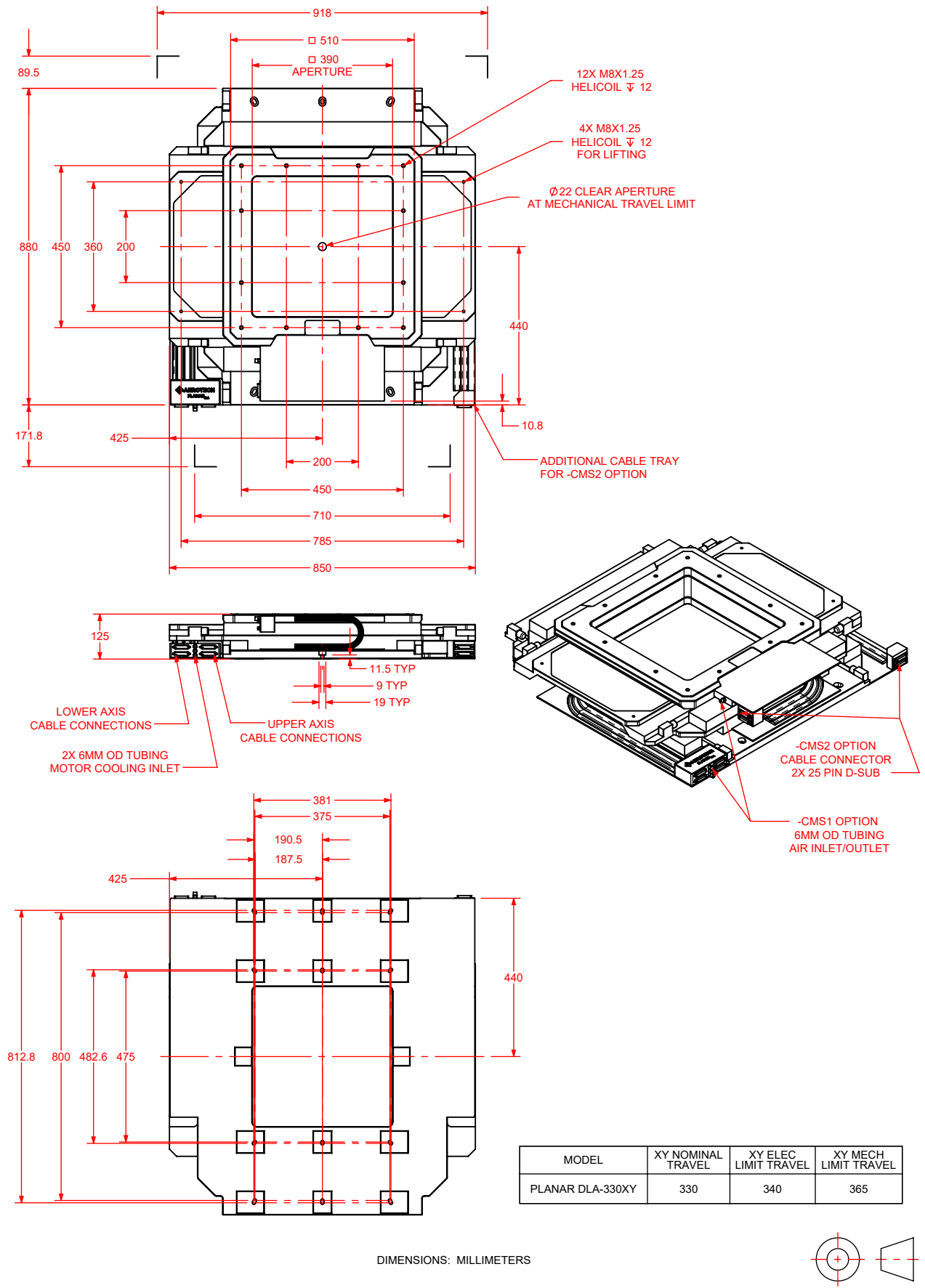

### Planar<sub>DLA</sub> Two Axis Mechanical-Bearing Direct-Drive Stage with Aperture

---

PlanarDLA-150XY	Planar <sub>DLA</sub> -150XY two axis mechanical-bearing direct-drive stage with aperture, 150 x 150 mm travel
PlanarDLA-250XY	Planar <sub>DLA</sub> -250XY two axis mechanical-bearing direct-drive stage with aperture, 250 x 250 mm travel
Planar <sub>DLA</sub> -330XY	Planar <sub>DLA</sub> -330XY two axis mechanical-bearing direct-drive stage with aperture, 330 x 330 mm travel

### Motor (Required)

---

-M1	1 motor on lower axis, 1 motor on upper axis
-M2	1 motor on lower axis, 2 motors on upper axis
-M3	2 motors on lower axis, 1 motor on upper axis
-M4	2 motors on lower axis, 2 motors on upper axis

### Feedback (Required)

---

-E1	Incremental encoders, 1 Vpp on upper and lower axes
-E2	Incremental encoders, 0.1 um TTL on upper axis, 1 Vpp on lower axis
-E3	Incremental encoders, 1 Vpp on upper axis, 0.1 um TTL on lower axis
-E4	Incremental encoders, 0.1 um TTL on upper and lower axes

### Cable Management(Optional)

---

-CMS1	Cable management for air/vacuum line
-CMS2	Cable management for air/vacuum line and 3rd axis motor/feedback

### Performance Grade (Required)

---

-PL1	Base performance
-PL3	High-accuracy performance, PLUS
-PL4	Ultra-high accuracy 2D performance, ULTRA

Note: -PL3 and -PL4 performance grades require Aerotech controller.

### Integration (Required)

---

Aerotech offers both standard and custom integration services to help you get your system fully operational as quickly as possible. The following standard integration options are available for this system. Please consult Aerotech if you are unsure what level of integration is required, or if you desire custom integration support with your system.

-TAS	Integration - Test as system Testing, integration, and documentation of a group of components as a complete system that will be used together (ex: drive, controller, and stage). This includes parameter file generation, system tuning, and documentation of the system configuration.
-TAC	Integration - Test as components Testing and integration of individual items as discrete components that ship together. This is typically used for spare parts, replacement parts, or items that will not be used together. These components may or may not be part of a larger system.