

# ABL8000 Series

## Air Bearing, Direct-Drive Linear Stage

Available with up to 1000 mm travel

High-accuracy linear encoder

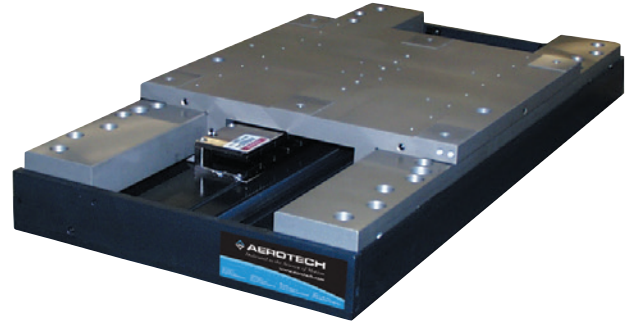

Leading-edge manufacturing demands positioning tolerances beyond the capability of conventional ball-screw and mechanical-bearing positioning systems. The ABL8000, with its air-on-air preload, exceptionally high stiffness, and excellent geometric characteristics was designed specifically to meet those demands.

### Air-Bearing Design

The ABL8000 incorporates an active preload on both the vertical and horizontal surfaces. The opposing thin-film pressure maintains the bearing nominal gap tolerance. This design, in addition to the large air-bearing surface that distributes the load over a large surface area, results in a stage with outstanding stiffness that is ideal for heavy or offset loading.

Proprietary manufacturing techniques result in a stage with superior geometrical characteristics. The air bearing has an inherent averaging effect that maximizes performance. The thin film will fill small surface voids and allow for other irregularities. This characteristic yields superior pitch, roll, yaw, straightness and flatness specifications.

### Linear Motor Drive

The driving force behind this stage is Aerotech's BLM series brushless linear servomotor. The BLM utilizes an ironlessforcer, which means there is zero cogging and no attractive forces – resulting in unrivaled smoothness of motion. Capable of generating high force and velocity, the BLM represents the ultimate combination of power and performance.

### Zero Maintenance

The noncontact air bearing, noncontact linear motor drive, and noncontact feedback device ensure years of maintenance-free operation at the high performance levels that are expected of Aerotech equipment. Because there is no mechanical contact between moving elements, the ABL8000 experiences no wear or reduction in performance over time. Service life is virtually unlimited and since there is no lubrication – only clean, dry gas – air bearings are ideal for clean room and medical applications.

### Cable Management

We carefully optimize the cable bend radius to ensure years of trouble-free operation. In the unlikely event of failure, Aerotech's modular design makes cable replacement quick and easy with minimal downtime.

To facilitate integration into the final system, we include all customer-required cables, air hoses, etc. in our CMS bundle. Both ends are fully connectorized for simple integration into the customer's machine.

## ABL8000 Series SPECIFICATIONS

Mechanical Specifications		ABL8000-0200	ABL8000-0300	ABL8000-0400	ABL8000-0500	ABL8000-0750	ABL8000-1000	
Total Travel <sup>(1)</sup>		200 mm	300 mm	400 mm	500 mm	750 mm	1000 mm	
Accuracy <sup>(2)</sup>	-E2 Encoder, Uncalibrated	±5.0 µm					±6.0 µm	±7.0 µm
	-E1 Encoder, Uncalibrated	±8.0 µm	±11.5 µm	±14.0 µm	±15.75 µm	±18.5 µm	±20.0 µm	
	-E1 and -E2 Encoders, Calibrated <sup>(3)</sup>	±0.5 µm		±0.75 µm		±1.0 µm		
Bidirectional Repeatability <sup>(2)</sup>		±0.2 µm			±0.3 µm	±0.4 µm		
Straightness <sup>(2)</sup>		±0.4 µm	±0.75 µm	±1.5 µm	±2.0 µm	±3.0 µm	±4.0 µm	
Flatness <sup>(2)</sup>		±0.4 µm	±0.75 µm	±1.5 µm	±2.0 µm	±3.0 µm	±4.0 µm	
Pitch		2 arc sec	3 arc sec	4 arc sec	5 arc sec	7.5 arc sec	10 arc sec	
Roll		2 arc sec	3 arc sec	4 arc sec	5 arc sec	7.5 arc sec	10 arc sec	
Yaw		2 arc sec	3 arc sec	4 arc sec	5 arc sec	7.5 arc sec	10 arc sec	
Maximum Speed <sup>(4)</sup>	-E2 Encoder	1.2 m/s						
	-E1 Encoder	2.0 m/s						
Maximum Acceleration		2 g (No-Load)						
Load Capacity <sup>(7)</sup>	-SC	Horizontal		70 kg				
		Side		30 kg				
	-LC	Horizontal		120 kg				
		Side		50 kg				
Operating Pressure <sup>(6)</sup>		517-551 kPa						
Air Consumption <sup>(9)</sup>	-SC	36 SLPM per Axis						
	-LC	58 SLPM per Axis						
Moving Mass	-SC	10 kg						
	-LC	16 kg						
Stage Mass	-SC	55 kg	62 kg	70.5 kg	78.5 kg	98 kg	116.5 kg	
	-LC	70 kg	77 kg	85.5 kg	93.5 kg	113 kg	131.5 kg	
Material		Aluminum						
MTBF		30,000 Hours						

Notes:

- When mounting the ABL8000 in an XY configuration, maximum upper axis length is 400 mm.
- Certified with each stage.
- Available with Aerotech controllers.
- Maximum speed based on stage capability; maximum application velocity may be limited by system data rate and system resolution.
- Maximum load based on bearing capability; maximum application load may be limited by acceleration requirements.
- To protect air bearing against under-pressure, an in-line pressure switch tied to the motion controller/amplifier ESTOP input is recommended.
- Air supply must be clean, dry to 0°F dewpoint and filtered to 0.25 µm or better; recommend nitrogen at 99.9% purity.
- Specifications are for single-axis systems, measured 25 mm above the tabletop. Performance of multi-axis systems is payload and workpoint dependent. Consult factory for multi-axis or non-standard applications.

Electrical Specifications		
Feedback	-E2 Encoder	Incremental Encoder; 4 µm Fundamental Period
	-E1 Encoder	Incremental Encoder; 20 µm Fundamental Period
Electronic Resolution		See signal period options on Order Information
Maximum Bus Voltage		80 VDC
Limit Switches		5 V, Normally Closed
Home Switch		Near Center

Recommended Controller		
Multi-Axis	A3200	Ndrive MP/Ndrive CP/Ndrive HLe/Npaq MXR
	Ensemble	Ensemble MP/Ensemble CP/Ensemble HLe/Epaq
Single Axis	Soloist	Soloist MP/Soloist CP/Soloist HLe

Notes:

- Linear amplifiers are required to achieve the listed specifications. Other options are available.

## ABL8000 Series SPECIFICATIONS

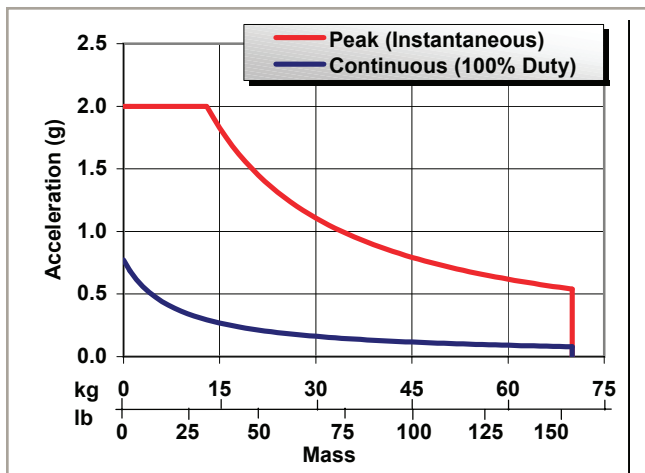

*Acceleration vs. Mass*

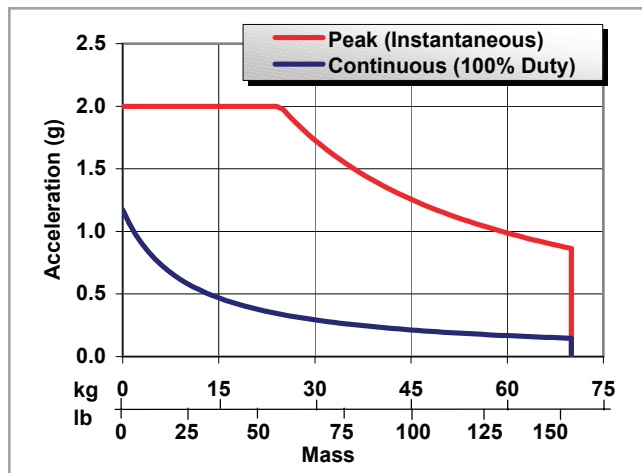

*Acceleration vs. Mass (ABL8000-LC)*

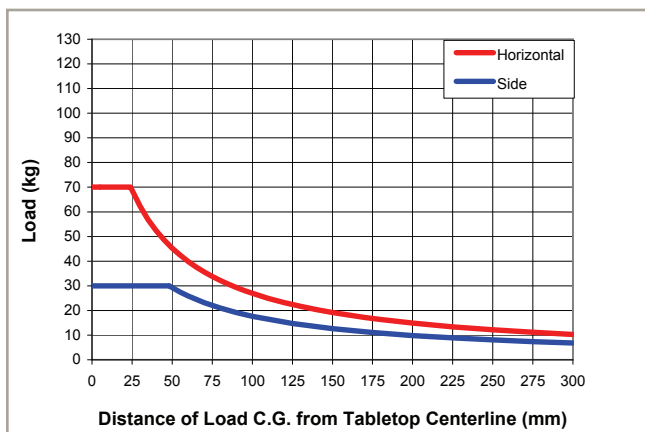

*ABL8000-SC Cantilevered Load Capability*

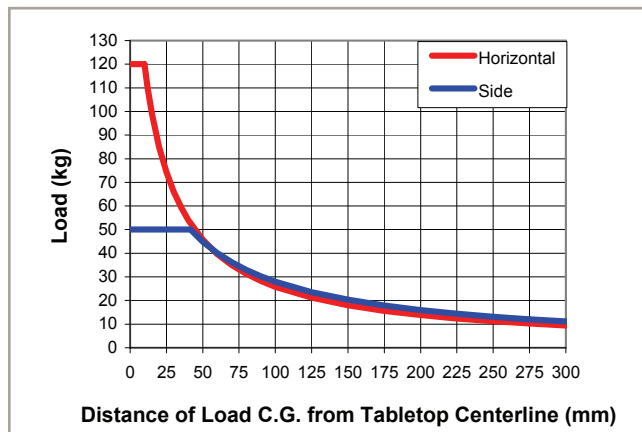

*ABL8000-LC Cantilevered Load Capability*



*The ABL8000 is typically provided as a complete XY assembly with integrated cable management for customer cabling, as well as a granite mounting base.*

ABL8000 Series DIMENSIONS

ABL8000-SC

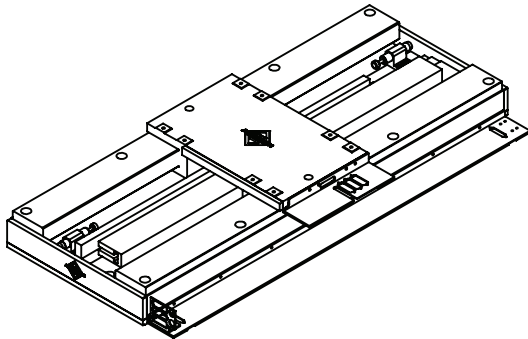
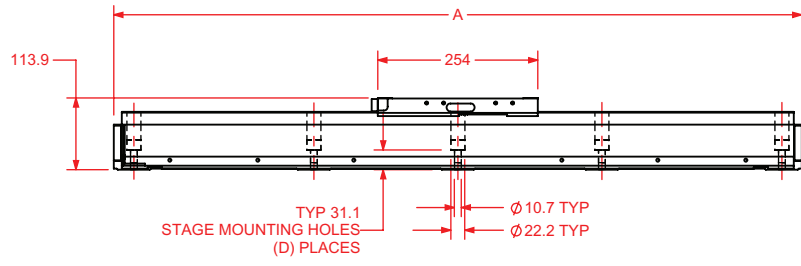
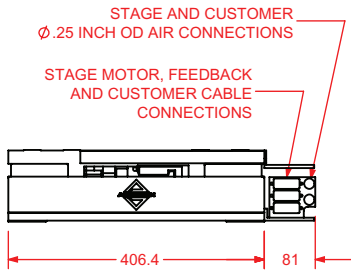
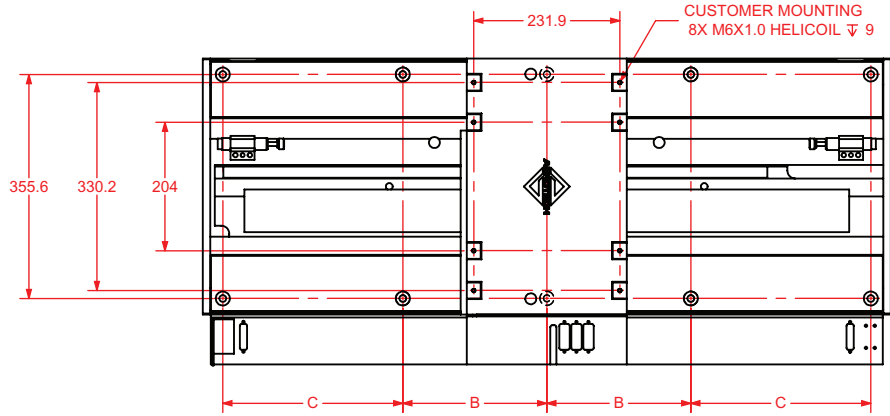

BASIC MODEL	NOMINAL TRAVEL	A	B	C	D
ABL8000-0200-SC	200	533.4	177.8	-	6
ABL8000-0300-SC	300	635.0	177.8	-	6
ABL8000-0400-SC	400	736.6	228.6	-	6
ABL8000-0500-SC	500	838.2	228.6	-	6
ABL8000-0750-SC	750	1092.2	228.6	285.8	10
ABL8000-1000-SC	1000	1346.2	228.6	285.8	10

DIMENSIONS: MILLIMETERS

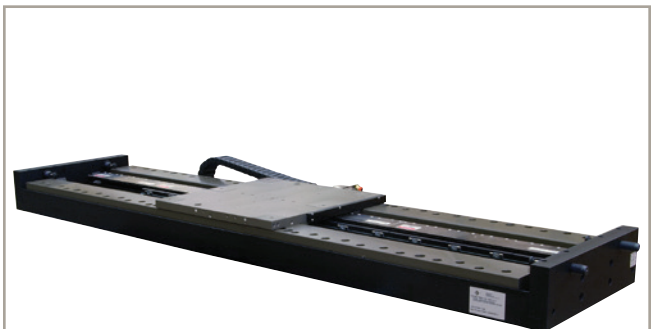

An example of a single axis, 1000 mm travel ABL8000 without granite.

# ABL8000 Series DIMENSIONS

## ABL8000-LC

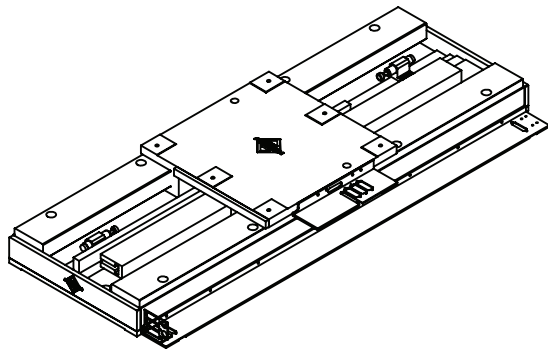
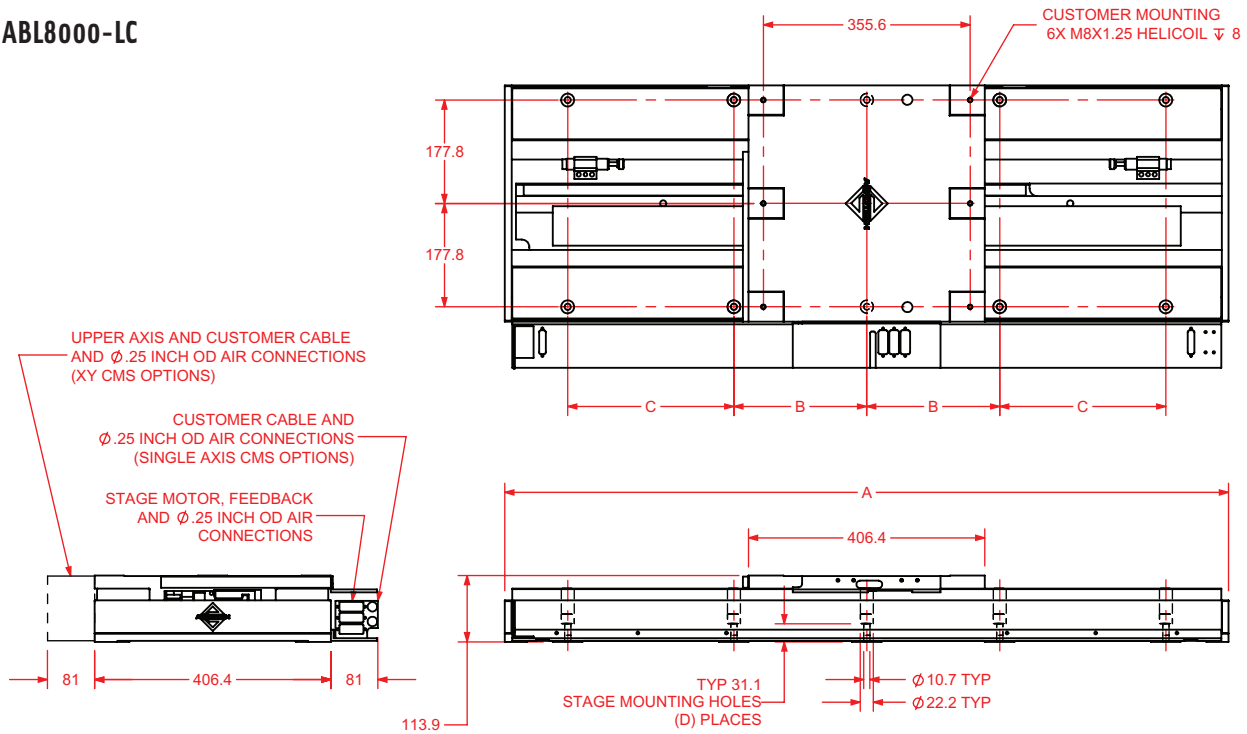

BASIC MODEL	NOMINAL TRAVEL	A	B	C	D
ABL8000-0200-LC	200	685.8	228.6	-	6
ABL8000-0300-LC	300	787.4	228.6	-	6
ABL8000-0400-LC	400	889.0	228.6	-	6
ABL8000-0500-LC	500	990.6	228.6	-	6
ABL8000-0750-LC	750	1244.6	228.6	285.8	10
ABL8000-1000-LC	1000	1498.6	228.6	285.8	10

DIMENSIONS: MILLIMETERS

## ABL8000 Series ORDERING INFORMATION

### Linear Stage Travel (Required)

---

-0200	200 mm travel
-0300	300 mm travel
-0400	400 mm travel
-0500	500 mm travel
-0750	750 mm travel
-1000	1000 mm travel

### Carriage (Required)

---

-SC	Short carriage - 250 mm length
-LC	Long carriage - 400 mm length

Note: In an XY-assembled configuration, the -LC option is required for the lower (X) axis, and the -SC option with a maximum travel of 400 mm is required for the upper (Y) axis.

### Limits (Required)

---

-LI1	Normally-closed, 5V end-of-travel limit switches
-LI2	Normally-open, 5V end-of-travel limit switches

### Feedback (Required)

---

-E1	Incremental linear encoder; 1 Vpp
-E2	Incremental linear encoder; high accuracy, 1 Vpp

### Cable Management (Optional)

---

-CMS1	External cable management system for single axis
-CMS2	External cable management system for single axis w/air/vac line
-CMS3	External cable management system for single axis w/signal cable
-CMS4	External cable management system for single axis w/air/vac line and signal cable
-CMS5	External cable management system for lower-axis of XY
-CMS6	External cable management system for lower-axis of XY w/air/vac line
-CMS7	External cable management system for lower-axis of XY w/signal cable
-CMS8	External cable management system for lower-axis of XY w/air/vac line and signal cable

### Metrology (Required)

---

-PL1	Metrology, uncalibrated with performance plots
-PL2	Metrology, calibrated (HALAR) with performance plots

### Integration (Required)

---

Aerotech offers both standard and custom integration services to help you get your system fully operational as quickly as possible. The following standard integration options are available for this system. Please consult Aerotech if you are unsure what level of integration is required, or if you desire custom integration support with your system.

-TAS	Integration - Test as system Testing, integration, and documentation of a group of components as a complete system that will be used together (ex: drive, controller, and stage). This includes parameter file generation, system tuning, and documentation of the system configuration.
-TAC	Integration - Test as components Testing and integration of individual items as discrete components that ship together. This is typically used for spare parts, replacement parts, or items that will not be used together. These components may or may not be part of a larger system.

### Accessories (to be ordered as separate line item)

---

ABF	Air bearing filtration kit
-----	----------------------------