

---

**6020  
SWITCHING SERVO  
CONTROLLER  
USER'S MANUAL**

**PN: EDA113**



**AEROTECH, INC., 101 Zeta Drive, Pittsburgh, PA 15238  
(412) 963-7470 • TWX 710-795-3125 • FAX(412)963-7459**

---

**Copyright © 1976 by Aerotech, Inc.**  
**December, 1988**

## TABLE OF CONTENTS

<u>Section</u>	<u>Contents</u>	<u>Page</u>
1.0	DESCRIPTION	1-1
2.0	SPECIFICATIONS	2-1
2.1	Maximum Ratings	2-1
2.2	Electrical Characteristics	2-1
2.3	Mechanical Characteristics	2-1
3.0	INSTALLATION AND OPERATION	3-1
3.1	Input/Output Connections	3-1
3.1.1	115v AC Input	3-1
3.1.2	Input Commands	3-1
3.1.3	Directional Current Limits	3-1
3.1.4	Load Connections	3-2
3.1.5	Supplies for External Use	3-2
3.2	Compensation	3-2
3.3	Adjustments	3-3
3.3.1	Current Limit Adjustments	3-3
3.3.2	Gain & Scale Factor Adjustments	3-3
3.3.3	Balance Adjustment	3-4
4.0	MAINTENANCE	4-1
5.0	TROUBLESHOOTING	4-1
5.1	Motor Runs Away	4-1
5.1.1	Open Tachometer	4-1
5.1.2	Tach Phasing	4-1
5.1.3	Power Amplifier Latch-up	4-1
5.1.4	Pre-amplifier Latch-up	4-2
5.2	Fuse Blows	4-2

TABLE OF CONTENTS

(Continued)

<u>Section</u>	<u>Contents</u>	<u>Page</u>
5.2.1	F1 Open	4-2
5.2.2	F2 Open	4-2
5.2.3	F3 Open	4-3
5.3	Poor Servo Response or Regulation	4-3
5.4	System Oscillation	4-3

## 1.0 Description

The Aerotech Model 6020 (60-volt, 20-amp) switching servo controller provides a unique combination of compact design, high output power, efficiency and ease of operation. It consists of a 741-type pre-amplifier with rate and position loop compensation, driving a power amplifier configured in a current feedback mode.

The preamplifier has three adjustable scale factors for the inverting input, a non-inverting input, balance adjustment and a gain adjustment for the lag-lead compensation. The lag-lead network, along with the three inverting input resistors, are mounted on stand-offs for quick, easy replacement.

The power stage operates in the switching mode (Class D) for high efficiency and freedom from power dissipation requirements. The 5 KHz constant switching frequency enables wide bandwidth operation with low ripple current and negligible form factor. Forced air cooling is provided to increase reliability by decreasing critical component temperatures.

Adjustable current limiting prevents motor demagnetization and directional current limits, initiated by limit switch or relay closures, decrease the torque available in only one direction for limited-travel motor loads.

The fused, isolated, internal power supply operates from 115 VAC and provides all necessary operating voltages, in addition to regulated  $\pm 15$  volts for external use.

## 2.0 Specifications

### .1 Maximum Ratings - (25°C unless otherwise specified)

Peak output current. . . . .	±24 amps
Pulse output current . . . . .	±20 amps
Continuous output current. . . . .	±5 amps
Peak output voltage. . . . .	±60 volts
Operating temperature. . . . .	0° to 50°C
Storage temperature. . . . .	-30° to 80°C
AC line voltage. . . . .	125 VAC

### .2 Electrical Characteristics

#### PREAMPLIFIER:

Voltage gain . . . . .	100db, open loop
Offset. . . . .	Adjustable to zero
Drift . . . . .	10 uv/°C, referred to in <sub>1</sub>

#### POWER AMPLIFIER:

Gain . . . . .	2 amps/volt
Current limit . . . . .	5-20 amps
Bandwidth . . . . .	DC to 1 KHz
Power output	
Peak. . . . .	1000 watts
Continuous. . . . .	225 watts
Switching frequency . . . . .	5 KHz
Form factor . . . . .	FF = $\sqrt{1 + (1.24/LI)^2}$
Regenerative energy	
capability. . . . .	20 joules
Torque limits (TB 6&7 or	
7&8)* . . . . .	Limits to 2.5 amps
Remote shutdown	
(TB 8&6)* . . . . .	Limits to 1 amp
Load inductance,	
minimum . . . . .	0.5 millihenry

#### POWER SUPPLY:

AC input voltage. . . . .	105-125 VAC
Frequency . . . . .	50/60 Hz
External +15 VDC. . . . .	30mA

### .3 Mechanical Characteristics

Weight. . . . .	18 lbs.
Dimensions. . . . .	6.7" wide x 9 1/4" long x 6.0" high
Mounting dimensions . . . . .	5 1/2 x 3 5/8"
Mounting screws . . . . .	1/4-20, 3/8" max. depth into controller baseplat

\* Requires a closure with current-handling capability of 20 mA.

### 3.0 Installation and Operation

#### 3.1 Input/Output Connections

##### 3.1.1 115v AC Input

The input power required is 115v AC, 5 amp. The fan requires a 50/60 Hz source. AC input terminals are TB1-9 and 10. TB1-10 is fused with a 5 amp slo-blow 3AG fuse. The power transformer generates 80 volt center-tapped AC which is applied to TB2-18 and 19.

##### 3.1.2 Input Commands

Four inputs are available for input and feedback signals. Inputs 1, 2, and 3 sum to the inverting input of the preamplifier, and TB1-5 enters the non-inverting input. Any of these inputs can be used for command or feedback signals. Aerotech drive systems usually connect tachometer feedback to 3 and velocity commands or position feedback to input 1. The input impedances range from about 5 to 10K ohm as can be seen from the data sheet functional schematic. Input signal commons should be connected to TB1-4 or 6; these commons are connected on the card to power ground, TB2-13.

##### 3.1.3 Directional Current Limits

TB1-7 and 8 are available to inhibit current flow of a specific polarity for limited travel motor loads. If TB1-7 is connected to TB1-6, current flow is inhibited from TB2-16 to 17 but not from TB2-17 to 16. If TB1-7 is connected to TB1-8, current flow is inhibited from TB2-17 to 16 but not from TB2-16 to 17. If TB1-6 is connected to TB1-8, all current flow is inhibited.

#### 3.1.4 Load Connections

The load is connected from TB2-16 to 17 and "floats". Connecting either TB2-16 or 17 to ground can damage the power stage. If the load inductance is less than 0.5 millihenry, a choke must be connected in series with the load. The load ripple current is shown on the data sheet graph as a function of load inductance.

#### 3.1.5 Supplies for External Use

Regulated + and - 15 VDC at .03 amp is available at TB2-12 and 11 for customer use. 15v common can be pin 4, 6 or 13. Unregulated +60 VDC is available at TB2-15, the current drawn from this supply plus the load current should not exceed the continuous current capability of the unit. 60v common is TB2-13.

#### 3.2 Compensation

The preamplifier compensation consists of a lag-lead network shown on the data sheet functional schematic, with the frequency response shown on the preamplifier transfer function graph. The lag is caused by C11 and the lead results from R20. An additional lag at about 1000 Hz results from the 1.5K / .1uf input filter on each of the three inverting inputs. The DC gain is determined by the input resistance and potentiometer setting (R7 and pot R6 for input 1) along with R18 and the two .1M ohm resistors on either side. For example, with R6 max. CW the preamplifier DC gain would be about 2500 v/v (68 DB); since the power amplifier is 2 amp/volt, overall DC gain is 5000 amp/volt. The AC gain is a function of frequency, R6 and R22 potentiometer settings, as shown on the pre-amplifier transfer function graph.



### 3.3 Adjustments

#### 3.3.1 Current Limit Adjustments

The current limit can be adjusted by monitoring TB2-20 (3300 ohm output impedance, .4 volt per amp) and varying R24 (CW decreases output current). For current limits below the continuous capability of the amplifier: start with R24 max CW, stall the system (command the motor to rotate and physically restrain it so that it can't) and rotate R24 CCW until the proper voltage is obtained at TB2-20.

For current limits greater than the continuous capability of the amplifier, scope TB2-20 and command the motor to step or reverse speed. Adjust R24 to obtain the desired peak current.

#### 3.3.2 Gain and Scale Factor Adjustments

Scale factor adjustments are R6, R9 and R12 for inputs 1, 2, and 3 respectively. The GAIN adjustment is R22. Connect the tachometer to input 3, turn R12 and R22 max CW, connect the motor and apply AC power. If the system runs away when AC power is applied, reverse the motor or tach connections. If the motor rotates slowly in either direction, adjust the balance, R16. Adjust R22 CCW until the motor oscillates, then adjust CW until oscillations cease - continue 1/8 to 1/16 turn further. Apply velocity commands or position feedback to input 1 or 2 and adjust scale factor for that input to obtain proper speed or response.

Input 1 will command greater speed than input 2 because R7 is smaller than R10. If the speed is too fast with the scale factor full CC, increase R7 or R10. If the speed is too slow with the scale factor full CW, R12 can be adjusted CCW - if R12 is adjusted, R22 will require readjustment.

### 3.3.3 Balance Adjustment

The pre-amplifier balance (R16) should be adjusted so that with zero input command, the tach voltage or current monitor voltage is minimum. Or visually observe the motor and adjust R16 until the motor does not rotate. If it is determined that the balance is difficult to adjust and DC gain can be sacrificed, R18 can be increased.

#### 4.0 Maintenance

This solid state servo controller requires no maintenance. If it is desired, the balance can be checked per 3.3.3 at 3 or 6 month intervals; and the PC card and heat sinks for an accumulation of dirt if operated in a dirty environment.

#### 5.0 Troubleshooting

Troubleshooting will be aimed at determining whether the unit is defective and needs to be returned to the factory for repair. The symptoms will be those for a motor/tach system.

#### 5.1 Motor Runs Away

If the motor runs at max. speed with no input commands, the problem can be an open tach, wrong tach phasing, or power amplifier failure.

##### 5.1.1 Open Tachometer

Measure the tachometer input terminals and verify that tachometer feedback voltage is being returned.

##### 5.1.2 Tach Phasing

If the tachometer phasing is questioned, the simplest check is to reverse motor or tach leads.

##### 5.1.3 Power Amplifier Latch-Up

To verify that the 6020 power stage is not latched-up, short TB1-8 to 6. This will command zero current out and TB2-16 and 17 should be switching between 60 and 0 volts at a 5K Hz rate; if one output is a constant B+ and the other zero, the power stage has failed.

#### 5.1.4 Pre-Amplifier Latch-up

To verify the preamplifier is not at fault: remove all input signals and lift one side of R18 (this places the preamp in a low DC gain). The voltage at TB1-8 should be less than a volt.

#### 5.2 Fuse Blows

If the AC fuse (F1) blows, see 5.2.1

If the DC fuse (F2) blows, see 5.2.2

If the DC fuse (F3) blows, see 5.2.3

##### 5.2.1 F1 Open

The AC fuse open usually indicates a power supply failure or power stage short. Remove F2 and replace F1; if F1 opens, the power supply is shorted, - verify that TB2-15 is not shorted.

##### 5.2.2 F2 Open

The DC supply fuse opening usually indicates a short in the power stage. Remove AC power, the load, and ohmmeter the power stage by:

1. Replace F2
2. Place the + lead of the ohmmeter (X1 scale) on TB2-15 and the - lead to TB2-16 then 17.
3. Place the - lead on TB2-13 and the + lead to TB2-16 then 17.
4. None of the four readings should be less than 100 ohms.

- NOTE -

If ohmmeter polarities are not observed, low resistance readings will be measured even for a good power stage.

5. If the above reading indicate good, check the load for a short to ground.

### 5.2.3 F3 Open

The load fuse opening usually indicates a shorted (to ground) load or a current demand greater than the continuous capability. Check for motor shorts to ground. Before replacing the fuse, remove AC power and the load, replace F3 and check the power stage with an ohmmeter by performing steps 5.2.2.1 through 5.2.2.4.

### 5.3 Poor Servo Response or Regulation

Poor servo response usually results from improper servo compensation (not enough gain) or adjustment (see sections 3.2 and 3.3), or failure to replace R18.

### 5.4 System Oscillation

An unstable system usually results from too much loop gain or mechanical resonances. Scope the tach and observe the frequency of oscillation. If mechanical resonances are suspected, remove the tach feedback, lift one end of R18, turn R22 full CCW, and apply a variable frequency sine wave to a command input. The sine wave magnitude should be low enough so that the current capability of the amplifier is not exceeded. Vary the sine wave frequency through the range of the oscillation that was observed with the tach connected. A mechanical resonance will be indicated by a sizeable increase (factor of 10) in tach voltage as the frequency is increased.

## AEROTECH, INC. SALES OFFICES

### **World Headquarters AEROTECH, INC.**

101 Zeta Drive  
Pittsburgh, PA 15238

Phone (412) 963-7470  
FAX (412) 963-7459  
TWX (710) 795-3125

### **AEROTECH NORTHEAST**

Executive Suite 120  
270 Farmington Avenue  
Farmington, CT 06032  
Phone (203) 673-3330  
or (203) 673-2503  
FAX (203) 674-1536

MA, CT, VT, ME, RI, NH, eastern  
NY

### **AEROTECH CENTRAL-WEST**

26791 Lake Vue Drive #8  
Perrysburg, OH 43551  
Phone (419) 874-3990  
FAX (419) 874-4280  
MI, IN, KY, western OH

### **AEROTECH, CENTRAL- EAST**

856 Cottonwood Drive  
Monroeville, PA 15146

Phone (412) 373-4160  
FAX (412) 373-4163  
WV, western PA, western NY,  
eastern OH

### **AEROTECH SOUTHWEST**

6001 Village Glen Drive  
#3101  
Dallas, TX 75206  
Phone (214) 987-4556  
FAX (214) 987-4706  
TX, OK, LA, AR, CO, UT, MT,  
WY, ID, NM

### **AEROTECH NORTHWEST**

444 Castro Street  
Suite 400  
Mountain View, CA 94041  
Phone (415) 967-4996  
FAX (415) 967-4998  
northern CA, OR, WA, NV

### **AEROTECH WEST**

Suite 217  
7002 Moody Street  
La Palma, CA 90623  
Phone (213) 860-7470  
FAX (213) 860-4639  
AZ, southern CA

### **AEROTECH MID-ATLANTIC**

521 Kingwood Road  
King of Prussia, PA 19406

Phone (215) 265-6446  
FAX (215) 265-3566  
MD, DC, DE, NJ, northern  
VA, eastern PA

### **AEROTECH SOUTH ATLANTIC**

8804 Lomas Court  
Raleigh, NC 27615  
Phone (919) 848-1965  
FAX (919) 848-3393  
NC, TN, southern VA, AL, FL,  
GA, SC, MS

## INTERNATIONAL SALES OFFICES

### AEROTECH LTD.

3 Jupiter House, Calleva Park  
Aldermaston  
Berkshire RG7 4QW England  
Phone (07356) 77274  
TLX 847228  
FAX (07356) 5022

### AEROTECH GMBH

Neumeyerstrasse 90  
8500 Nuernberg 10  
West Germany  
Phone (0911) 521031  
TLX 622474  
FAX (0911) 521235

### AEROTECH AUSTRALASIA

224 Carr Street  
Suite 7  
Leederville 6007  
Western Australia  
Phone (619) 227-6772  
FAX (619) 227-6670

## INTERNATIONAL REPRESENTATIVES

### BRASITEC

Rua Americo Brasiliense, 2069  
Chacara Santo Antonio  
Cep 04715 - Sao Paulo - SP  
Brazil  
Phone (5511) 523 4044  
TLX 1130691 BRTC  
FAX (5511) 521 0221

### Y. BEN MOSHE

PO Box 18125  
Tel Aviv 61181  
Israel  
Phone (9723) 7515007  
or (9723) 7513268  
TLX 342436 BMS IL  
FAX (9723) 727319

### SIMCO

248, Hauz Rani Market  
Opposite Press Enclave  
New Delhi 110 017 India  
Phone 6443684  
TLX 031-62176 HARS IN  
FAX (9111) 510697

### OPTIKON CORPORATION LTD.

410 Conestogo Road  
Waterloo, Ontario  
Canada, N2L 4E2  
Phone 519-885-2551  
FAX 519-885-4712

### DONG DO TRADING CO. LTD.

Rm 903, Kwang Sung Bldg.  
831-47 Youksamdong  
Kangnam-Ku, Seoul, Korea  
Phone (822) 556-2292  
FAX (822) 556-2902  
TLX 29734 DONG DO

### TOKYO INSTRUMENTS INC.

Asahi-Seimei Bldg.  
6-8-10 Nishikasai  
Edogawa-Ku  
Tokyo 134 Japan  
Phone (813) 686-4711  
FAX (813) 686 0831

### HISCO (MALAYSIA) SDN.BHD.

1 Lorong SS13/6A  
Subang Jaya Indust. Estate  
47500 Petaling Jaya  
Selangor, Malaysia  
Phone (603) 733-4236  
FAX (603) 733-6281  
TLX 36226 HISCO MA

### HADLAND PHOTONICS PTY. LTD.

19A Hampshire Road  
Glen Waverley  
Victoria, 3150, Australia  
Phone (613) 560 2366  
FAX (613) 560 8402  
TLX AA 35670



## Warranty and Field Service Policy

---

Aerotech, Inc. warrants its products to be free from defects caused by faulty materials or poor workmanship for a minimum period of one year from date of shipment from Aerotech. Aerotech's liability is limited to replacing, repairing or issuing credit, at its option, for any products which are returned by the original purchaser during the warranty period. Aerotech makes no warranty that its products are fit for the use or purpose to which they may be put by the buyer, whether or not such use or purpose has been disclosed to Aerotech in specifications or drawings previously or subsequently provided, or whether or not Aerotech's products are specifically designed and/or manufactured for buyer's use or purpose. Aerotech's liability on any claim for loss or damage arising out of the sale, resale or use of any of its products shall in no event exceed the selling price of the unit.

### Laser Product Warranty

Aerotech, Inc. warrants its laser products to the original purchaser for a minimum period of one year from date of shipment. This warranty covers defects in workmanship and material and is voided for all laser power supplies, plasma tubes and laser systems subject to electrical or physical abuse, tampering (such as opening the housing or removal of the serial tag) or improper operation as determined by Aerotech. This warranty is also voided for failure to comply with Aerotech's return procedures.

### Return Products Procedure

Claims for shipment damage (evident or concealed) must be filed with the carrier by the buyer. Aerotech must be notified within (30) days of shipment of incorrect materials. No product may be returned, whether in warranty or out of warranty, without first obtaining approval from Aerotech. No credit will be given nor repairs made for products returned without such approval. Any returned product(s) must be accompanied by a return authorization number. The return authorization number may be obtained by calling an Aerotech service center. Products must be returned, prepaid, to an Aerotech service center (no C.O.D. or Collect Freight accepted). The status of any product returned later than (30) days after the issuance of a return authorization number will be subject to review.

### Returned Product Warranty Determination

After Aerotech's examination, warranty or out-of-warranty status will be determined. If upon Aerotech's examination a warrantied defect exists, then the product(s) will be repaired at no charge and shipped, prepaid, back to the buyer. If the buyer desires an air freight return, the product(s) will be shipped collect. Warranty repairs do not extend the original warranty period.

### Returned Product Non-Warranty Determination

After Aerotech's examination, the buyer shall be notified of the repair cost. At such time the buyer must issue a valid purchase order to cover the cost of the repair and freight, or authorize the product(s) to be shipped back as is, at the buyer's expense. Failure to obtain a purchase order number or approval within (30) days of notification will result in the product(s) being returned as is, at the buyer's expense. Repair work is warranted for (90) days from date of shipment. Replacement components are warranted for one year from date of shipment.

### Rush Service

At times, the buyer may desire to expedite a repair. Regardless of warranty or out-of-warranty status, the buyer must issue a valid purchase order to cover the added rush service cost. Rush service is subject to Aerotech's approval.

### On-Site Warranty Repair

If an Aerotech product cannot be made functional by telephone assistance or by sending and having the customer install replacement parts, and cannot be returned to the Aerotech service center for repair, and if Aerotech determines the problem could be warranty-related, then the following policy applies.

Aerotech will provide an on-site field service representative in a reasonable amount of time, provided that the customer issues a valid purchase order to Aerotech covering all transportation and subsistence costs. For warranty field repairs, the customer will not be charged for the cost of labor and material. If service is rendered at times other than normal work periods, then special service rates apply.

If during the on-site repair it is determined the problem is not warranty related, then the terms and conditions stated in the following "On-Site Non-Warranty Repair" section apply.

### On-Site Non-Warranty Repair

If an Aerotech product cannot be made functional by telephone assistance or purchased replacement parts, and cannot be returned to the Aerotech service center for repair, then the following field service policy applies.

Aerotech will provide an on-site field service representative in a reasonable amount of time, provided that the customer issues a valid purchase order to Aerotech covering all transportation and subsistence costs and the prevailing labor cost, including travel time, necessary to complete the repair.

---

AEROTECH, Inc., 101 Zeta Drive, Pittsburgh, Pennsylvania 15238

Phone (412) 963-7470 • TWX 710-795-3125 • FAX (412) 963-7459



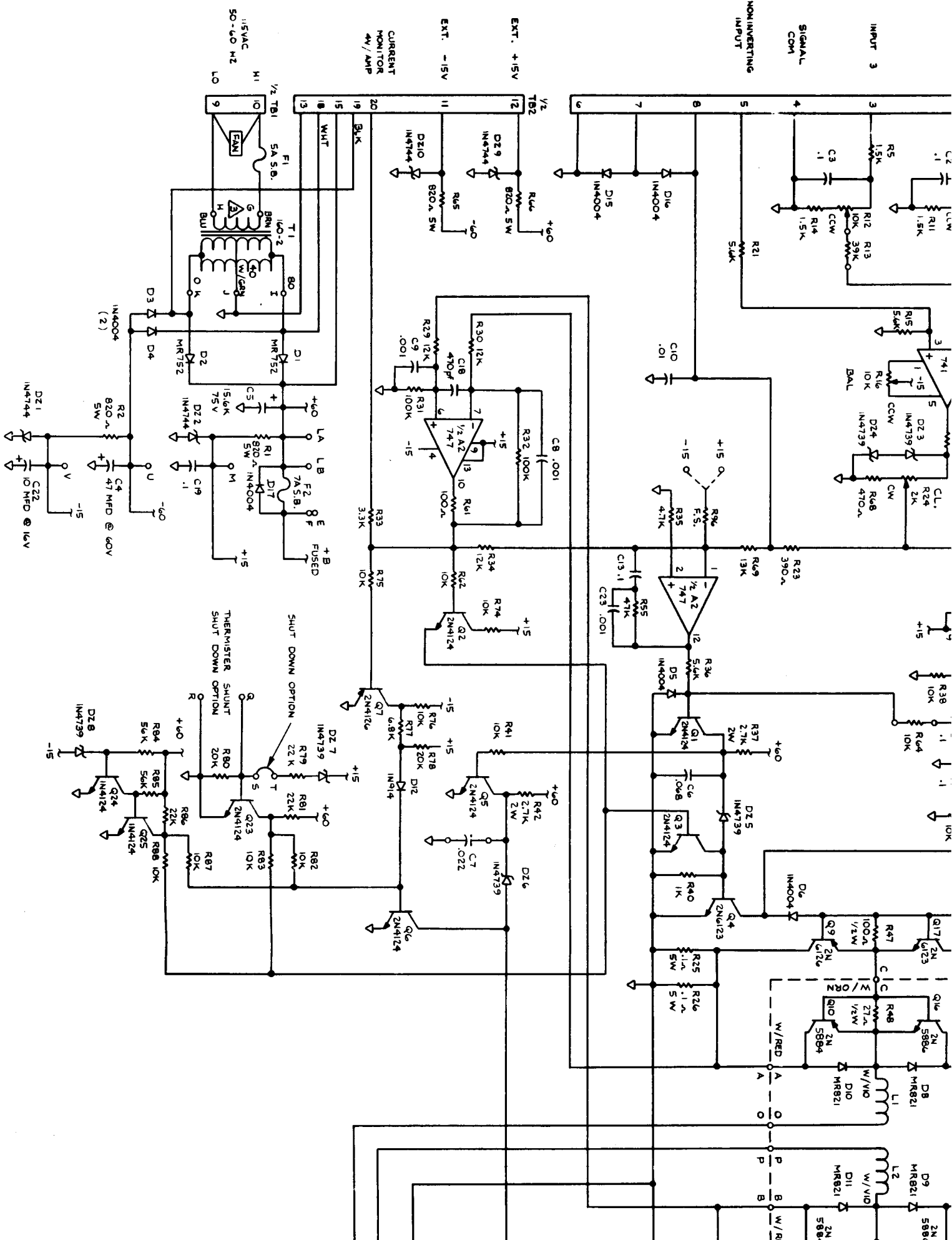

6

5

4

3

REV	DATE	DESCRIPTION	BY	APPROVAL
G		NEW SHEET	D. SIKOTA	
F	8/1/78	CHNG D.I. F3 MS TAB	D. SIKOTA	
H	1/1/79	MAKE THIS SHEET	D. SIKOTA	
J	1/21/79	CHANGE THIS SHEET	D. SIKOTA	
K	1/21/79	"	D. SIKOTA	

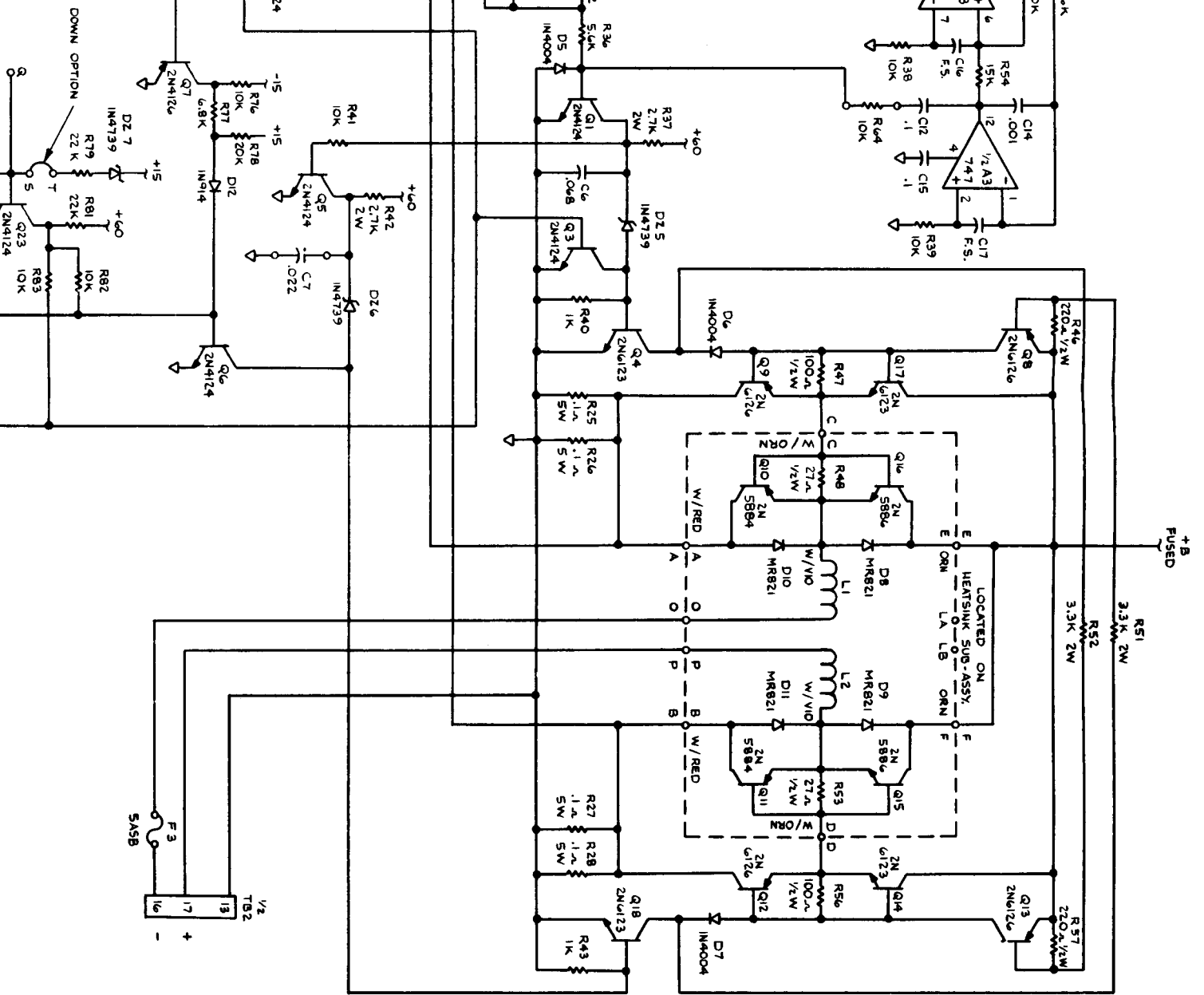

TI 568-125 115V / 230V WIRING (EAX115)

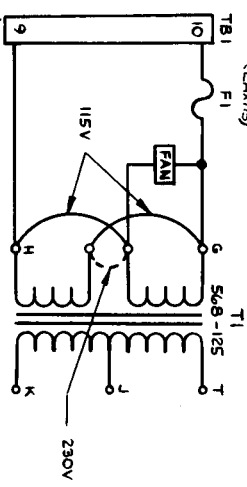

- 1) ALL RESISTORS ARE 1/4 W 5% EXCEPT WHERE NOTED
- 2) PC BOARD ASSEMBLY 690D1049, PC BOARD ARTWORK 690D1037

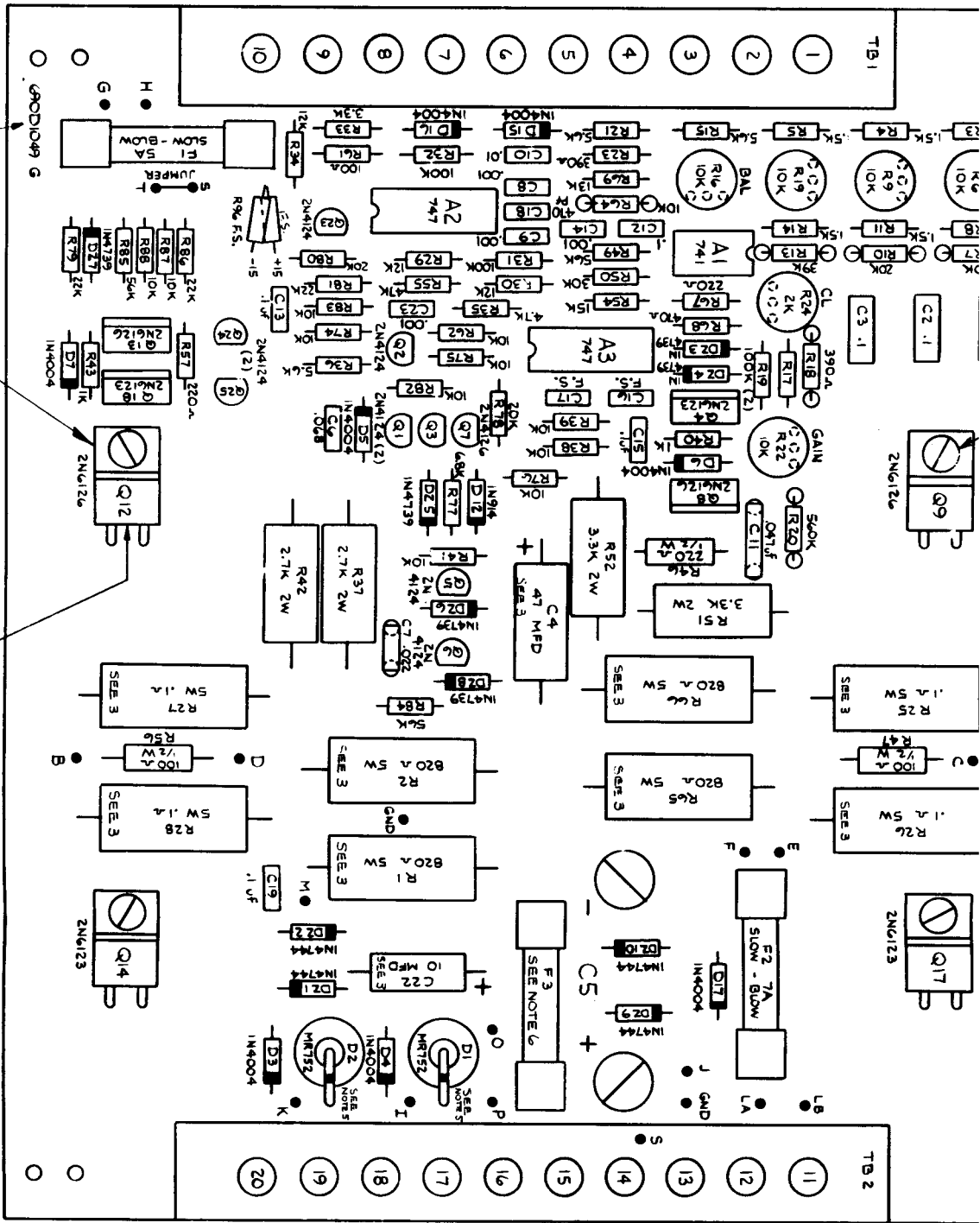

ETCH BOARD IN THIS AREA

MACK HOLES THAT ARE USED FOR MOUNTING OF COZOR HEAT SINKS TRANSISTORS AT Q1, Q2, Q4, Q7, Q14, Q17 (B.P.S.)

CUT CENTER LEAD (TYP. 4 P.S.)

5

4

3

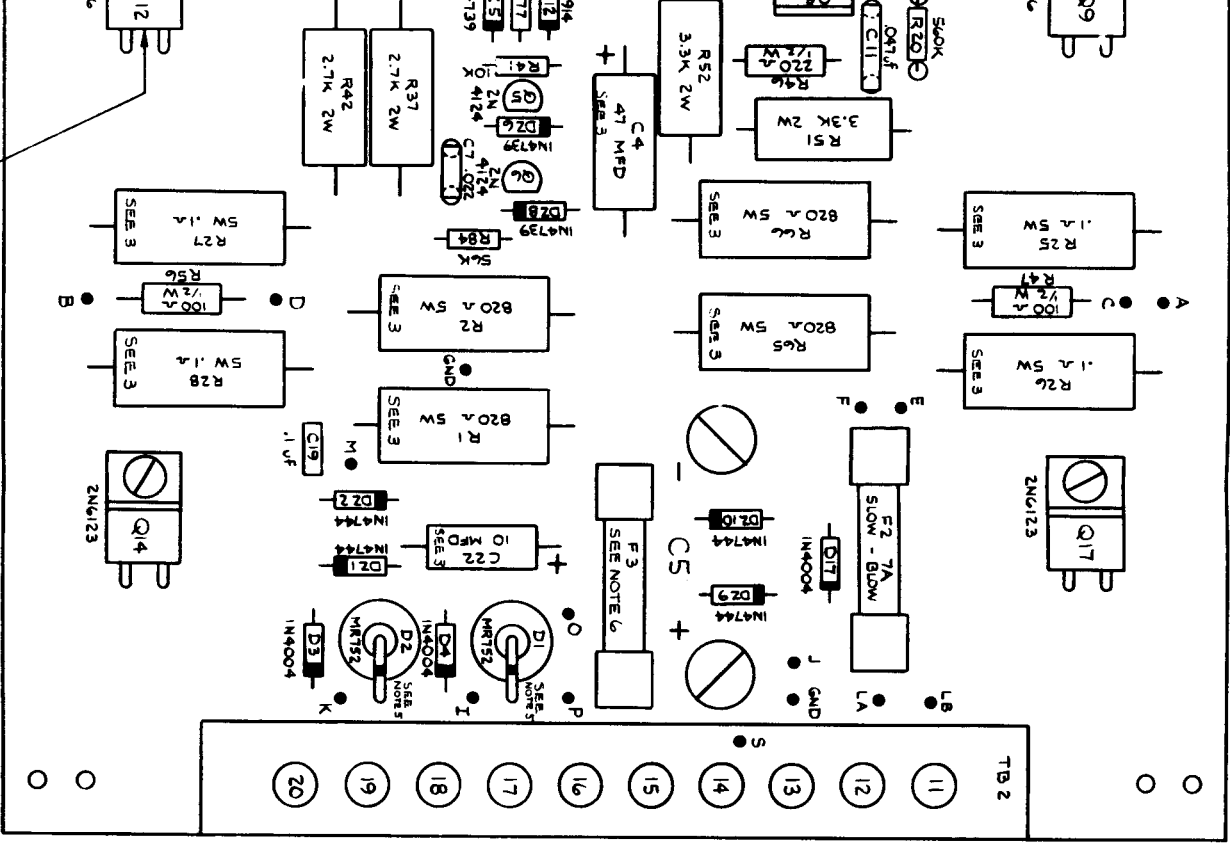

REV.	DATE	DESCRIPTION	BY	APPROVAL
F	7/9/6	NEW SHEET	D. Sauer	D. Sauer
G	9/17/6	CHANGE REV. TO MATCH GOODDIE REV LEVEL	D. Sauer	D. Sauer
H	9/17/6	EDGORN (OTDR, C1) WAS Q1, F3 WAS 7ASB	D. Sauer	D. Sauer
I		NO CHANGE THIS SHEET		
J	9/21/6	NO CHANGE THIS SHEET		
K	9/21/6	"		

- 1) SCHEMATIC DWG. IS 630D1022, PC BOARD ARTWORK IS 69D1037
- 2) ALL RESISTORS 1/4W 5% EXCEPT AS NOTED
- 3) MOUNT COMPONENTS LISTED OFF SURFACE OF BOARD  
C4, C22, R25 - R28, R65, R66, R11, R2
- 4) NO HEAT SINK IS REQUIRED WHEN PLASTIC TRANSISTORS ARE USED IN PLACE OF TO-60 UNITS (Q1, 12, 14, 17)
- 5) D1 & D2 MKT52 MOUNTING:  
ADD FIBER WASHER (E1H178) UNDER CATHODE

