**UNIDEX™ 11
MOTION CONTROLLER
HARDWARE MANUAL**

PN: EDU106



**AEROTECH, INC., 101 Zeta Drive, Pittsburgh, PA 15238
(412) 963-7470 • TWX 710-795-3125 • FAX(412)963-7459**

Copyright © 1988 by Aerotech, Inc.
December, 1988

DISCLAIMER:

The information contained in this manual is subject to change due to improvements in design. Though this document has been checked for inaccuracies, Aerotech does not assume responsibility for any errors contained herein.

TRADEMARKS:

Unidex is a registered trademark of Aerotech, Inc.

IBM PC/XT/AT are registered trademarks of the International Business Machines Corporation.

ORGANIZATION OF DOCUMENTATION FOR UNIDEX 11:

Up to four manuals may have been shipped with your Unidex 11 Controller, depending on the options ordered. Of the four manuals, two supply basic data regarding programming and hardware support information. These manuals are respectively:

- *Unidex 11 Motion Controller Programming Manual*
- *Unidex 11 Motion Controller Hardware Manual* – which is this manual

Depending on the options supplied with your Unidex 11, one or both of the following documents may have also been supplied:

- *Unidex 11 Motion Controller Options Manual*
- *Unidex 11 Interactive Control Software Manual (SSP1)*

Please review, in detail, *Unidex 11 Motion Controller Programming Manual*, before proceeding to this or any other documentation supplied with your Unidex 11.

ORGANIZATION OF THIS MANUAL:

This manual is comprised of general electrical and mechanical information regarding the Unidex 11 Family Of Controllers, which include the following:

- Unidex 11 4-Axis Desktop Configuration – Model U11S
- Unidex 11 4-Axis 19" Rack Mount Configuration – Model U11R
- Unidex 11 4-Axis Heavy-Duty 19" Rack Mount Configuration – Model U11H
- Unidex 11 2-Axis Desktop Configuration – Model U11M

An overview of the Unidex 11 Family of Controllers is provided in Part I, Chapter 1 of the *Unidex 11 Motion Controller Programming Manual*. (Photographs of these controllers are shown in figure 1-1 of this same section.)

Table of Contents

CHAPTER 1: INTRODUCTION.....	1
SECTION 1-1 ABOUT THIS MANUAL.....	2
CHAPTER 2: UNIDEX REAR PANEL CONNECTIONS.....	5
SECTION 2-1 UNIDEX 11 CONTROL CONNECTIONS.....	10
SECTION 2-2 LIMIT SWITCH, MARKER AND ENCODER	11
SECTION 2-3 AUXILIARY CONTROL CONNECTIONS	19
SECTION 2-4 INPUT/OUTPUT INTERFACE CONNECTOR.....	24
SECTION 2-5 OPTO-INTERFACE CONNECTOR.....	26
SECTION 2-6 JOYSTICK INTERFACE CONNECTOR.....	28
SECTION 2-7 RS-232 INTERFACE CONNECTOR.....	30
SECTION 2-8 IEEE-488 INTERFACE CONNECTOR.....	30
SECTION 2-9 DIGITAL I/O PORT & TDT THUMBWHEEL.....	31
SECTION 2-10 HIGH SPEED BINARY INTERFACE.....	31
SECTION 2-11 SERIAL OUTPUT (SEO) INTERFACE	32
SECTION 2-12 UNIDEX 11 POWER CONNECTIONS.....	37
CHAPTER 3: INTERNAL STRUCTURE OF UNIDEX 11.....	43
CHAPTER 4: STEPPING/DC SERVO DRIVE MODULES.....	53
SECTION 4-1 D3001/D1401 STEPPING DRIVES.....	53
SECTION 4-2 DM4001, 4005 & 1501 STEPPING DRIVES	64
SECTION 4-3 DM6006 STEPPING DRIVE MODULE.....	77
SECTION 4-4 DMV8008 AND DMV16008 DRIVE MODULES.....	89
SECTION 4-5 DSL8020 DRIVE MODULE.....	101
SECTION 4-6 POWER SUPPLY BOARD.....	120
SECTION 4-7: CONTROL BOARD.....	123
CHAPTER 5: STEPPING AND DC SERVO MOTORS.....	127
SECTION 5-1 HARDWARE SPECIFICATIONS.....	127
Service And Repair	
Index	
Warranty	

CHAPTER 1: INTRODUCTION

This manual contains general information, both electrical and mechanical, regarding the Unidex 11 Family of Controllers which include the following:

- Unidex 11 4-Axis Desktop Configuration – Model U11S
- Unidex 11 4-Axis 19" Rack Mount Configuration – Model U11R
- Unidex 11 Heavy-Duty 19" Rack Mount Configuration – Model U11H
- Unidex 11 2-Axis Desktop Configuration – Model U11M

(An overview of the Unidex 11 controllers, as well as a photograph of each is included in Part I, chapter 1 of the *Unidex 11 Motion Controller Programming Manual*.)

This manual also includes information regarding the operating specifications of the stepping and DC drive modules that are incorporated into the Unidex 11 Family of Controllers. These drive modules are:

Stepping Motor Drive Modules:

- D1401
- DM1501
- DM4005
- DMV8008
- D3001
- DM4001
- DM6006
- DMV16008

DC Motor Drive Module:

- DSL8020

An overview of the stepping and DC motor drive modules is provided in Part I, chapter 1 of *Unidex 11 Motion Controller Programming Manual*. Specifications for stepping drive/motor combinations are shown in table 1-2, with torque vs. speed curves in figure 1-3 of the same section. Specifications for DC Servo drive/motor combinations are shown in table 1-1, with torque vs. speed curves in figure 1-2 of the same section.

SECTION 1-1 ABOUT THIS MANUAL

The information provided in this manual pertains to hardware functionality of the Unidex 11 Family of Controllers. Following is a brief description of each chapter:

- | | |
|-------------------|--|
| Chapter 1: | Introduction. |
| Chapter 2: | Description of the external characteristics of the Unidex 11 Family of Controllers. This information includes descriptions of the rear panel external connections including electrical specifications for input/output control and power connections. Cross referencing of input/output connections to appropriate software (programming) information is provided where necessary to provide the user with an understanding of the overall control system. |
| Chapter 3: | Concise description of the internal organization of the Unidex 11 Family of Controllers. This information includes interfacing of the various stepping and DC servo drive modules with the Unidex 11 chassis. Simplified input power wiring diagrams for each Unidex 11 chassis are also provided. These diagrams are intended to aid in describing the interconnecting wiring used to select the various DC bus voltages (for DMV8008, DMV16008 and DSL8020 |

Modules), as well as wiring interconnections for 115 VAC or 230 VAC input power operation.

Chapter 4:

Provides information pertaining to the setup of the individual stepping and DC servo drive modules and Unidex 11 control board. This information is provided for the purpose of troubleshooting or performance adaption of the servo drives and control modules. Normally, the user need not concern himself with this information if the Unidex 11 system has been supplied with standard Aerotech motors and cables.

For applications where motor and cables are not supplied by Aerotech, the information provided in this chapter is intended to serve as a reference for adjustment of the given drive module.

Chapter 5:

Outlines the various DC servo and stepping motor assemblies normally supplied with the Unidex 11 Family of Controllers. Information is provided for electrical connections of external travel limit switches to the motor assemblies. (Aerotech motor cables are designed to allow the user to feed external limit switch signals back to the Unidex 11 controller).

CHAPTER 2: UNIDEX REAR PANEL CONNECTIONS

Outline drawings for the rear panels of the Unidex 11 Controllers are shown in figures 2-1, 2-2 and 2-3. For additional reference, photographs of the Unidex 11 Family of Controllers can be found in Part I, chapter 1 of the *Unidex 11 Motion Controller Programming Manual*.

Control and Power connections for all four chassis shown in figure 2-1, 2-2 and 2-3 are similar. A brief description of the various connectors is outlined below, using the U11S and U11R chassis in figure 2-1 as an example.

XJ1, YJ1, UJ1*, VJ1*	Power connections for stepping or DC servo motors. Connector is of two types, depending on the type of chassis used. (See section 2-12 and figure 2-7 for more information.)
J13, J14, J19*, J20*	Limit, marker, (and in the case of DC servo control, encoder interface) connectors for the X,Y,U and V drives are connected here. (See section 2-1 and 2-2, as well as figure 2-4 for more information).
J10, J11, J17*, J18*	Auxiliary control connections for the X,Y,U and V drives. The use of these connectors differs, depending on the type of Unidex 11 chassis used. (For Unidex 11 chassis U11R, U11S or U11H, see section 2-3 and figure 2-4 for more information. For Unidex 11 chassis U11M, see section 2-3 and figure 2-4 for more information.)
*	<i>Application for 4-axis chassis, U11-R, U11-S, and U11-H.</i>
J3	This connection is for the optional Unidex 11 Joystick control (see section 2-6 and figure 2-4 for more information).

- J5** The interface for the four conditional inputs (I1,I2,I3,I4) and four programmable outputs (O1,O2,O3,O4) are made at this connector (see section 2-4 and figure 2-4 for more information).
- J2** The connection for the RS-232C serial communication port is made at this connector (see section 2-7 and figure 2-4 for more information).
- J15** The connection for the optional IEEE-488 parallel communications port is made at this connector (see section 2-8 and figure 2-4 for more information).
- J6** This connector is supplied for direct interface to Opto-22 PB8, PB16 and PB24 Opto-Isolated interface boards. (These boards can be supplied by Aerotech as an option.) The input/output connections described for connector J5 above, as well as other control connections, are brought out on this connector. (See section 2-5 and figure 2-4 of this chapter for more information.)
- J21** This connector provides for the Digital I/O Port and Two-Digit Thumbwheel Interface Option (see Part IV of the *Unidex 11 Motion Controller Options Manual* and section 2-9 and figure 2-4 of this chapter for more information).
- J24** This connector provides for the High Speed Binary Interface option. (See Part V of the *Unidex 11 Motion Controller Options Manual* and section 2-10 and figure 2-4 of this chapter for more information.)
- NOTE:** Connectors J21 or J24 are mutually exclusive. Both connectors cannot be present at the same time.
- J22, J23** These connectors are supplied for the serial output (SEO) Option for Unidex 11. These optional connectors provide opto-coupled positioning data and status output signals relative to X, Y, U and V axes. (See section 2-11 and figure 2-4 for more information.)

CHAPTER 2: UNIDEX 11 REAR PANEL CONNECTIONS

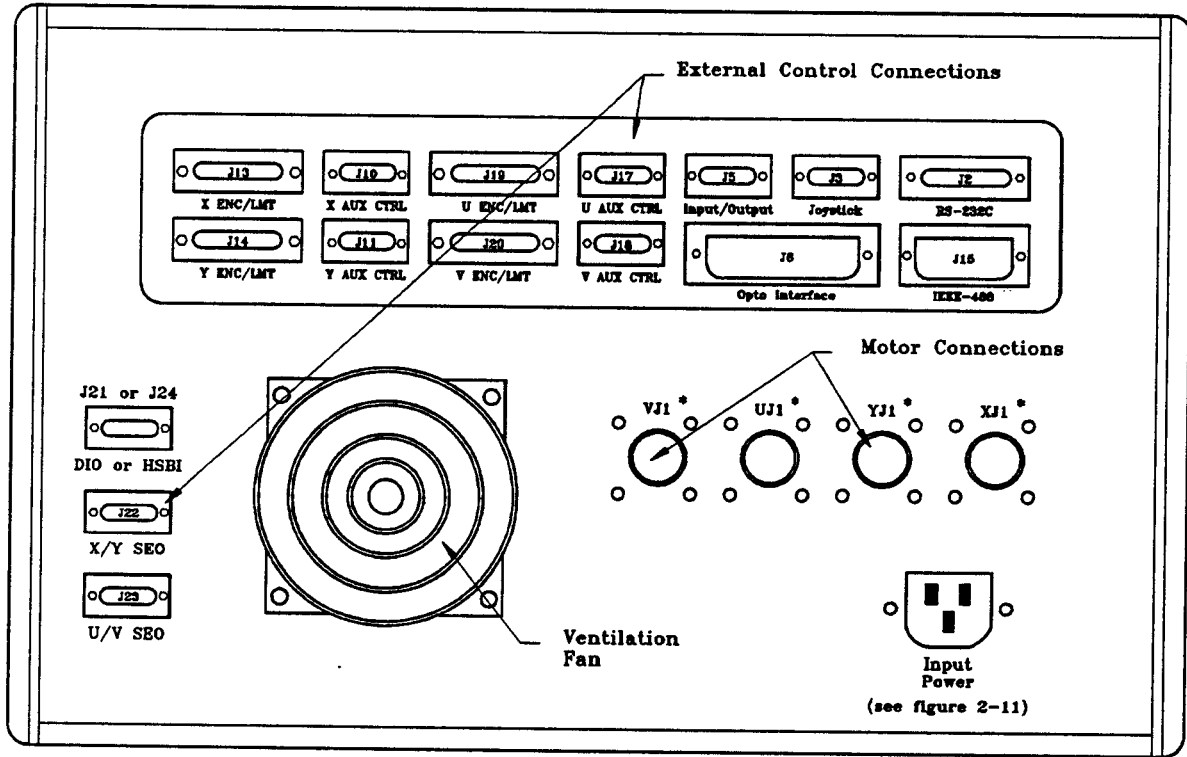

- * On certain chassis, the positions of XJ1, YJ1, UJ1 and VJ1 may differ from those shown here.

Figure 2-1: Rear Panel Outline of Unidex 11 4-Axis Desktop & 19" Rack Chassis (Models U11S & U11R)

CHAPTER 2: UNIDEX 11 REAR PANEL CONNECTIONS

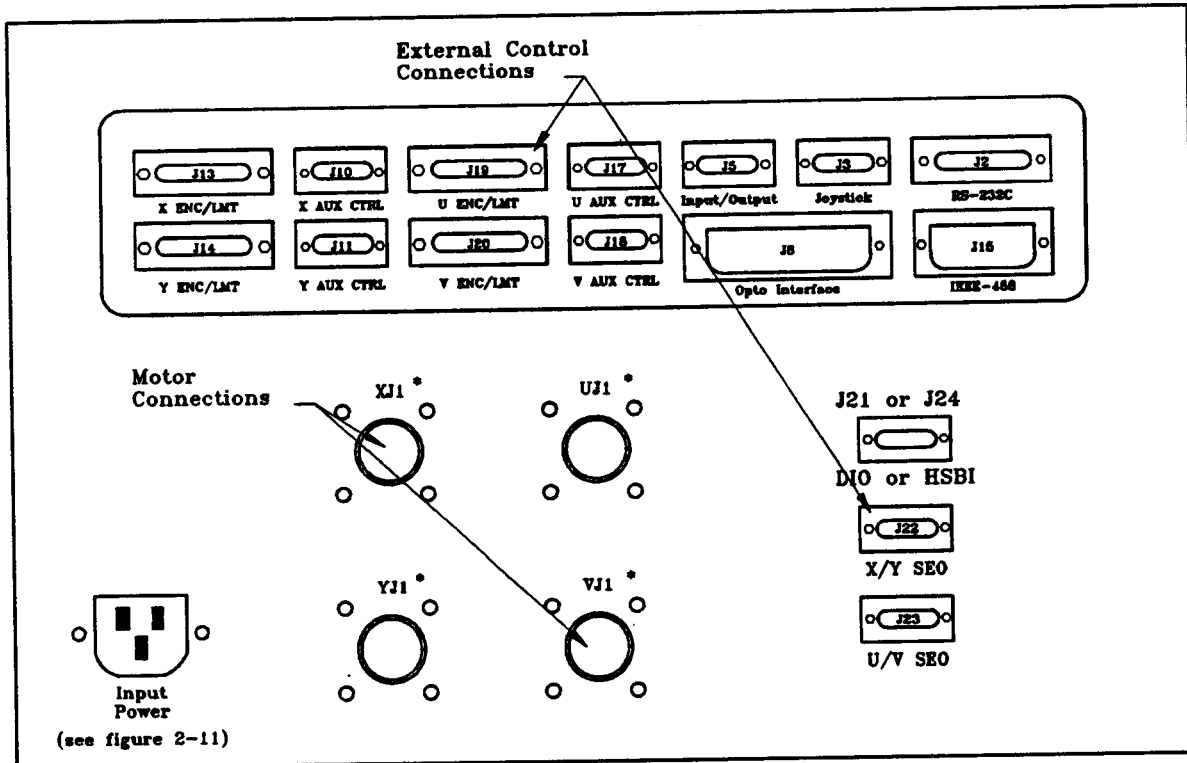

* On certain chassis, positions of XJ1, YJ1, UJ1 and VJ1 may differ from what is shown here.

Figure 2-2: Rear Panel Outline of the Unidex 11 Four Axis Heavy-Duty 19" Rack Chassis (Model U11H)

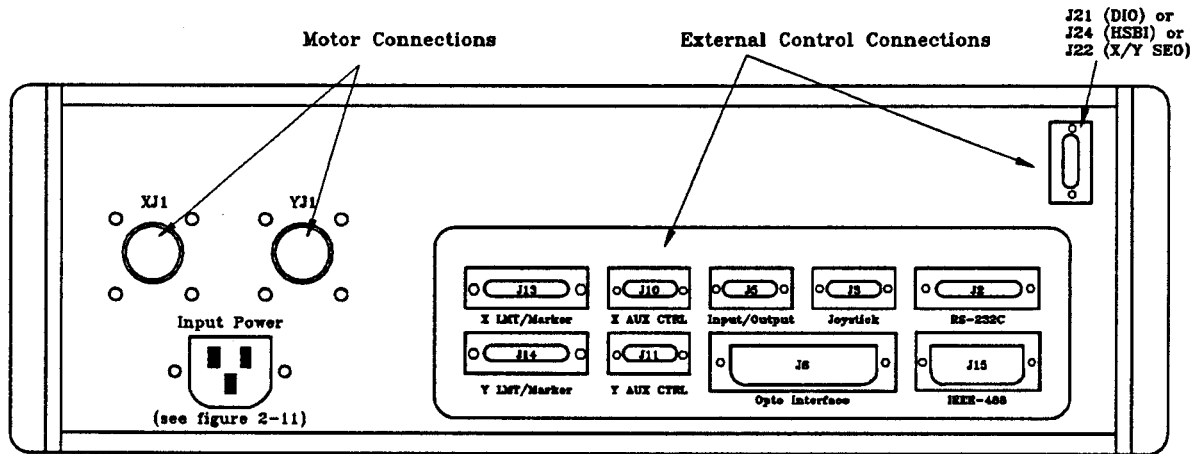

Figure 2-3: Rear Panel Outline of the Unidex 11 2-Axis Desktop Chassis (Model U11M)

SECTION 2-1 UNIDEX 11 CONTROL CONNECTIONS

The outline of the external control connectors shown in figures 2-1, 2-2 and 2-3 is detailed in figure 2-4. Aerotech supplies the mating connectors for each external control connector upon request.

For convenience, a list of mating connectors (and their manufacturers) for those connectors shown in figure 2-4 is presented in table 2-1:

Mating connector for 25 pin "female" "D" connectors J13, J14, J19 and J20	Molded cable type "male", Beldon, No. 49670 Solder pot type "male", TRW-CINCH, No. DBM-25P Ribbon connector type "male", TRW-CINCH, No. FC25P
Mating connector for 25 pin "male" "D" connector J2	Molded cable type "female", Beldon, No. 49675 Solder pot type "female", TRW-CINCH, No. DBM-25S Ribbon connector type "female" TRW-CINCH, No. FC25S
Mating connector for 15 pin "female" "D" connector J5, J21, J24	Molded cable type "male", Beldon, No. 49722 Solder pot type "male", TRW-CINCH, No. DAM-15P Ribbon connector type "male", TRW-CINCH, No. FC15P
Mating connector for 15 pin "male" "D" connectors J10, J11, J17, J18, J22, J23	Molded cable type "female", Beldon, No. 49727 Solder pot type "female", TRW-CINCH, No. DAM-15S Ribbon connector type "female", TRW-CINCH, No. FC15S
Mating connector for 50 pin "female" "Champ" connector J6	Ribbon cable type "male", 3M, No. 3564
Mating connector for 24 pin "female" "Champ" connector J15	Molded cable type "male", Beldon, No. 49644

Table 2-1: List of Mating Connectors for External Control Connectors Shown in Figure 2-4

SECTION 2-2 LIMIT SWITCH, MARKER AND ENCODER

Connections for X, Y, U, V Drives

NOTE: The following section describes the external control connections of the Unidex 11 (figures 2-1, 2-2, 2-3, 2-4) in more detail.

A. CONNECTOR SPECIFICATION

For J13, J14, J19 and J20 for U11S, U11R and U11H Chassis

NOTE: This subsection describes the connections for the U11S, U11R and U11H chassis. The U11M chassis connections are described in the next subsection (B).

Connectors J13, J14, J19 and J20 provide for the termination of the basic control interface signals between the X, Y, U and V stepping motor and/or DC servo motor and the Unidex 11. Motor travel limits and homing signals for each axis are terminated at these receptacles, as well as encoder signals for DC motor control. The pinouts are as follows (see figure 2-4 for receptacle outline).

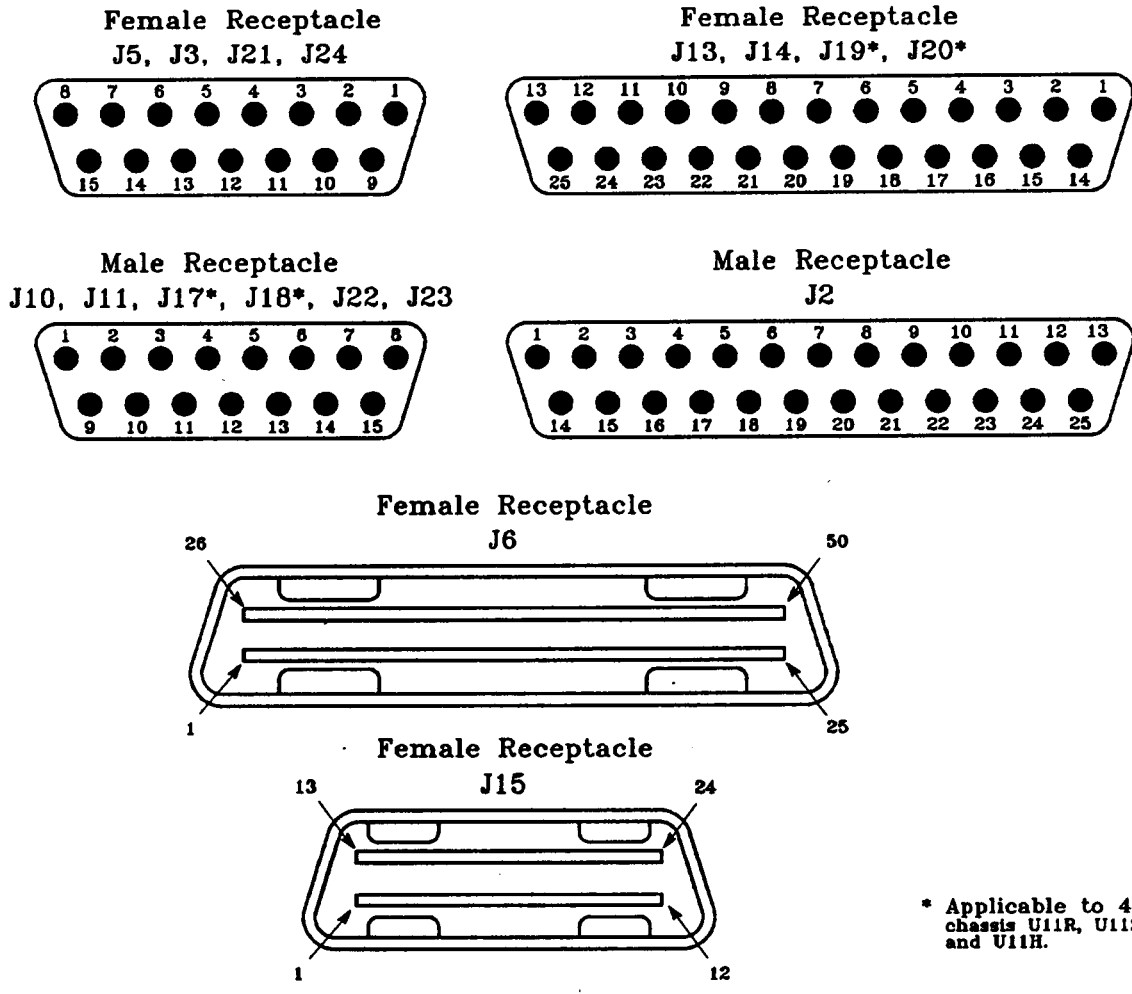

* Applicable to 4-axis chassis U11R, U11S and U11H.

Figure 2-4: Outline of Unidex 11 External Control Connectors

J13, J14, J19 and J20 (U11S, U11R, U11H Chassis):

<u>Pin #</u>	<u>Description</u>	<u>Comments</u>
	<i>FORM C</i>	<i>FORM A (normally open) or FORM B (normally closed)</i>
13 *	CW Limit (in)	No Connection
12 *	/CW Limit (in)	/CW or CW Limit (in)
25 *	CCW Limit (in)	No Connection
24 *	/CCW Limit (in)	/CCW or CCW Limit (in)
23 *	Home Limit (in)	No Connection
22 *	/Home Limit (in)	/Home or Home Limit (in)
7	Marker (in)	Encoder marker (or index pulse, see following diagram) for DC servo motor or separate marker (index pulse for stepping motor control). See chapter 4 for additional information.
6	/Marker (in)	
3, 16	+5VDC (200mA max)	
9,20,21	Signal Common	
4	Optional +5VDC (For Aerotech use only)	
1	Shield (Connector Retaining Screws are also connected to chassis frame)	
14	COS(in)	Encoder quadrature signals (see following diagram) for DC servo motor control. (Not applicable for stepping motor control).
15	/COS (in)	
17	SIN (in)	
18	/SIN (in)	
19	+ Tach Input	Optional tach for DC servo only Polarity indicated for CW motor rotation
8	- Tach Input	

* Form C Limit connections are "factory select" only. Form A Limit connections are the standard configuration shipped. Form B Limit connections

can be field selected on the given DC or stepping drive module (see chapter 4 for driver module specifications).

Encoder Input Specifications:

The Unidex 11 DSL8020 DC servo module can be factory set for:

1. Differential amplified sine wave encoder operation, or
2. Single-ended or differential square wave (line driver or TTL) encoder operation.

(See chapter 4, DSL8020 drive module specifications for information on encoder interface selection.) Electrical specifications for both sine and square wave encoder types are shown below:

Square Wave Encoder
(/COS, /SIN, and /Marker not shown, but similar)

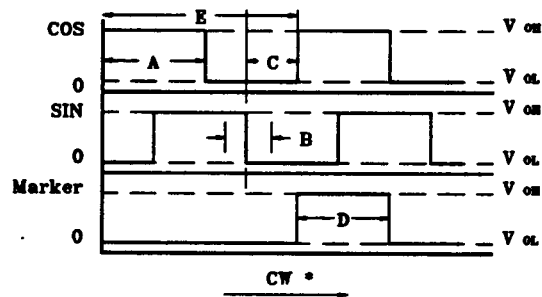

Sin Wave Encoder
(/COS, /SIN, and /Marker not shown, but similar)

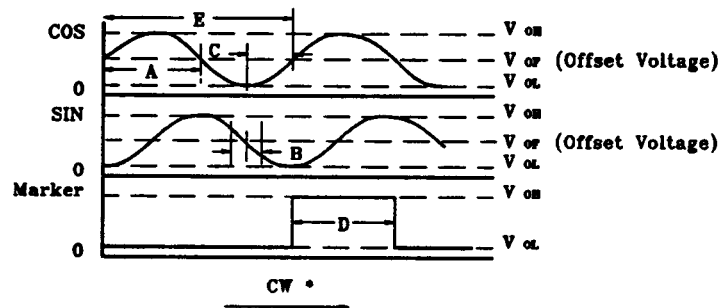

* Motor rotational reference, CW, is looking into the motor mounting flange. Encoder is assumed to be mounted on rear of motor.

Encoder Voltage Specifications:

<i>Specification</i>	<i>Sine Wave</i>	<i>Square Wave</i>
VOH	3.0 VMIN	2.4 VMIN
VOL	1 VMAX	.4 VMAX
VOFF	1.75 - 2.25 VTYP	----

Encoder Timing Specifications:

<i>Specification</i>	<i>Sine Wave</i>	<i>Square Wave</i>
A(Symmetry)	180° ± 10°Max	180° ± 10°Max
B(Jitter) ⁽¹⁾	± 20°Max	± 5°Max
C(Quadrature) ⁽¹⁾	90° ± 20°Max	90° ± 20°Max
D(Marker Width) ⁽²⁾	90°Min/270°Max	90°Min/270°Max
E(Period) ⁽³⁾	25µSec Min (40KHz)	13.3µSec Min (75KHz)

NOTE 1: Quadrature jitter at 35 KHz.

NOTE 2: The DSL8020 DC servo drive module internally masks the marker to "one" machine step, based on the logical "and" of the "positive" Sine and Cos single states.

NOTE 3: The maximum encoder frequency stated above is based on one full output cycle of the encoder (X1 mode). The DSL8020 can be field selected for X1, X2, or X4 interpolation of the encoder signals. The maximum data rate of the Unidex 11 system is 250kHz. When a sine wave encoder is used in the X4 mode, the maximum system data rate is 160kHz. When a square wave encoder is used in the X4 mode, the maximum system data rate would be 250kHz.

Single-ended square wave encoders can be accommodated by appropriately connecting the encoder to the sin, cos and marker connections, while leaving the /Sin, /Cos and /Marker points unconnected. (See chapter 4, DSL8020 Drive Module for more information regarding single-ended encoder operation.) (NOTE: For "noisy" environments, differential output encoders are recommended.)

The marker inputs connections are applicable for stepping as well as DC servo motor control. However, the electrical specifications for the marker inputs (pin 7 and 6) when used with stepping motor con-

trol, differ from the encoder marker specifications just previewed for DC servo control. (See chapter 4, D1401, D3001, DM1501, DM4001, DM4005, DM6006 and DMV16008/DMV8008 stepping drive module specifications for more information.)

B. CONNECTOR SPECIFICATIONS

For J13 and J14 for U11M Chassis

Connectors J13 and J14 provide for the termination of the basic control interface signals between the X and Y stepping motor and the Unidex 11 (DC servo control is not applicable to the U11M chassis). Motor travel limits and homing signals for each axis are terminated at these receptacles.

Pin #	Description	
	<i>Form C</i>	<i>Form A (Normally Open) or Form B (Normally Closed)</i>
13 *	CW Limit (in)	No Connection
12 *	/CW Limit (in)	/CW or CW Limit (in)
25 *	CCW Limit (in)	No Connection
24 *	/CCW Limit (in)	/CCW or CCW Limit (in)
23 *	Home Limit (in)	No Connection
22 *	/Home Limit (in)	/Home or Home Limit (in)
7	Marker (in)	 See chapter 4 for additional information
6	/Marker (in)	
3, 16 8,9,20,21	+5VDC (200mA, Max) Signal Common	
4	Optional +5VDC (For Aerotech use only)	
1	Shield (Connector retaining screws are also connected to chassis frame)	

14,15,17,18,19 (No Connection)

- * Form C limit connections are "factory select" only. Form A limit connections are the standard configurations shipped. Form B limit connections can be field selected on the given stepping drive module (see chapter 4, Drive Module Specifications, for more information).

C. SPECIFICATIONS COMMON TO SECTIONS A AND B

Form C connections for the CW, CCW and Home Limit inputs are optional. Form A and form B connections are standard, and are connected at pins 12, 24 and 22 respectively (see A and B of this section).

Form C, form A and form B contacts are defined for the CW limit as follows (CCW and home limits are similar).

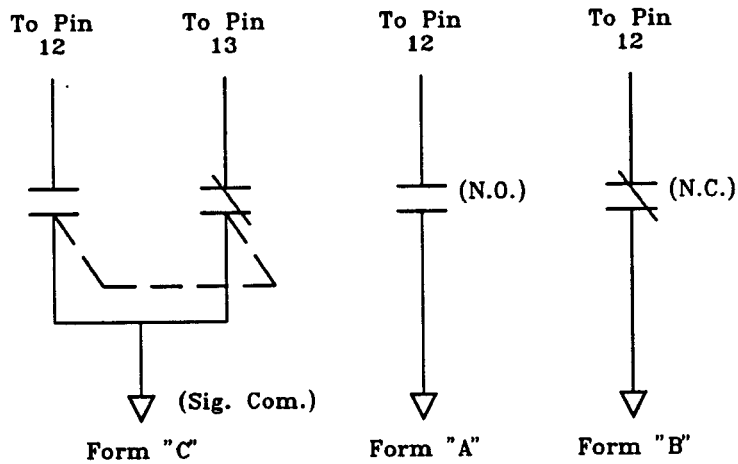

Contact Positions shown when not in limit.

When using form A or form B input connections, selections of polarity (normally open or normally closed) must be made on the appropriate stepping motor drive module or DC motor drive module through a set of programming jumpers (see chapter 4, Drive Module Specifications, for more information).

Normally, the polarity of these limits are factory set for form A (normally open).

All limit input configurations are internally buffered as shown below:

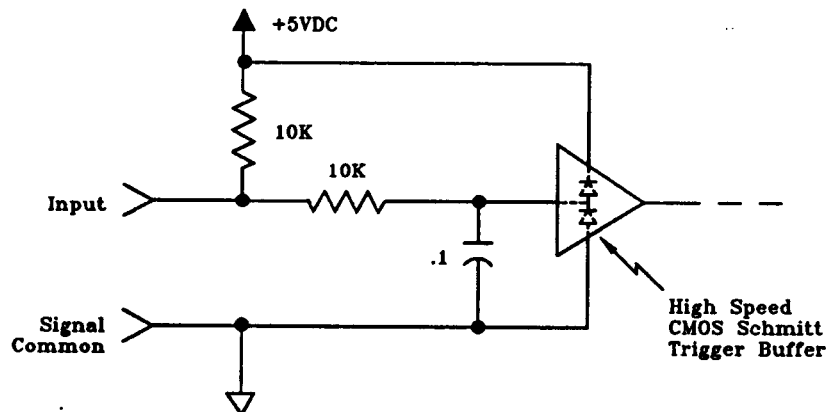

All limit inputs are protected against accidental over voltage of ± 30 volts. All logic inputs such as dry contact, open collector, TTL, 5 to 15 volt CMOS can be used.

The maximum current draw (per axis) on the +5VDC connections (pins 3 and 16) is 200 mA.

The presence of a visual indication for acknowledging CW limit, CCW limit and marker can be made by viewing the LED indicators on the front panel for a given axis. The LCD display also provides an indication of the presence of a limit or marker for the given axis.

The drive module specifications in chapter 4 of this manual provide more information concerning the limit switches, the home cycle, and marker references.

SECTION 2-3 AUXILIARY CONTROL CONNECTIONS

A. CONNECTOR SPECIFICATIONS

For U11S, U11R, and U11H Chassis:

J10, J11, J17 and J18 for DC Servo Motor Control

The auxiliary control connections for the U11S, U11R and U11H chassis are associated with connectors J10, J11, J17 and J18 for the X, Y, U and V axis respectively. For DC servo operation (using the DSL8020 drive module) the pin definitions for J10, J11, J17 and J18 are as follows:

DSL8020 Module – J10, J11, J17 and J18 (U11S, U11R, U11H Chassis)

<u>Pin #</u>	<u>Description</u>	<u>Function</u>
13	External clock (In) Max Frequency = 250KHz Min. Pulse Width = .5 μ S	Remote input clock and direction control (see section 2- 2M, Part II of the <i>Unidex 11 Motion Controller Programming Manual</i>)
6	External direction (In) Logic 1 = CW motor rotation. Logic 0 = CCW motor rotation.	

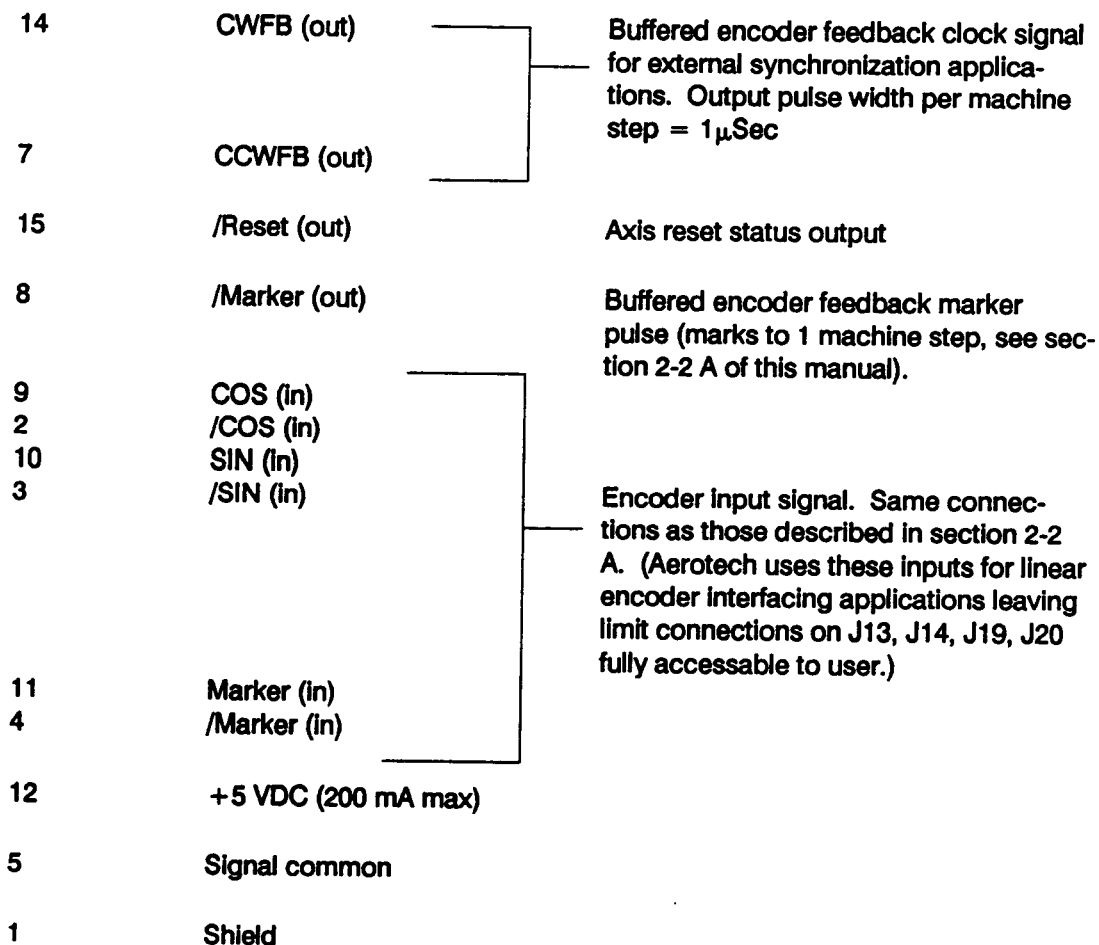

See section 2-3D for Auxiliary Control Electrical Specifications.

B. CONNECTOR SPECIFICATIONS

For the U11S, U11R and U11H Chassis

J10, J11, J17 and J18 for Low or High Power Stepping Motor Control

The auxiliary control connections for the U11S, U11R and U11H Chassis assume different pin-out definitions when used with the low power stepping motor drive modules (D1401, D3001, DM1501, DM4001, DM4005, DM6006) or high power stepping motor drive

modules (DMV8008, DMV16008). The pin definitions for these connectors when using the D, DM or DMV Series Stepping Modules are as follows:

D, DM or DMV Series—J10,J11,J17 & 18 (U11S, U11R, U11H Chassis)		
Pin #	Description	Function
13	External clock (in), Max Frequency = 250KHz. Min. Pulse Width = .5 μ S	Remote input clock and direction control (see <i>Unidex 11 Motion Controller Programming Manual</i> , Part II, section 2-2M).
6	External direction (in) Logic 1 = CW motor rotation Logic 0 = CCW motor rotation	
2-4, 7-12, 14, 15	(Connections not applicable to D1401, D3001, DM1501, DM4001, DM4005, DM6006, DMV8008 or DMV16008 use)	
5	Signal common	
1	Shield	

See section 2-3D for Auxiliary Control Electrical Specifications.

C. CONNECTION SPECIFICATIONS

For the U11M Chassis:

J10, J11 for Low Power Stepping Motor Control

NOTE: The auxiliary control connections are optional with the U11M Chassis.

The auxiliary control connections for the U11M chassis are associated with connectors J10 and J11, for the X and Y axis respectively. The U11M chassis is designed for operation with the D1401,

D3001, DM1501, DM4001 and DM4005 stepping driver modules only.
 The pin definitions for these connectors is as follows:

D1401, D3001, DM1501, DM4001, DM4005 - J10 and J11 (U11M Chassis)

<u>Pin #</u>	<u>Description</u>	
1	Shield	
2	Signal Common	
9	Signal Common	
10	/CCW Limit (out)	} Buffered output signals specifying input limit switch status
3	/CW Limit (out)	
11	/Home Limit (out)	
4	Zero (CZ) (out)	Buffered output signal specifying "Axis in Position" (or stationary).
8	External clock (in). Max Frequency = 250KHz. Min. Pulse Width = .5 μ S	} Remote input clock & direction control (see section 2-2M, Part II of the <i>Unidex 11 Motion Controller Programming Manual</i>).
15	External direction Logic 1 = CW motor rotation Logic 0 = CCW motor rotation	
14	/Slew (in) Factory set for speed of 120RPM, signal is active low.	} Remote input slew, step, direction control. (See section 2-2M, Part II of the <i>Unidex 11 Motion Controller Programming Manual</i> .)
13	Step (Normally closed) (in) (Form C input)	
6	/Step (Normally open) (in) (Form C input)	
7	Slew/step direction Logic 1 = CW motor rotation Logic 0 = CCW motor rotation	

NOTE: Only External CLK/DIR or Slew/Step/Direction commands are active at one time. External CLK/DIR is standard. If Slew/Step/Direction commands are required, please see appropriate drive section in chapter 4. (See section 2-3D for Auxiliary Control Electrical Specifications.)

D. AUXILIARY CONTROL ELECTRICAL SPECIFICATIONS

The circuit configuration below illustrates all inputs described in section 2-3, A, B and C.

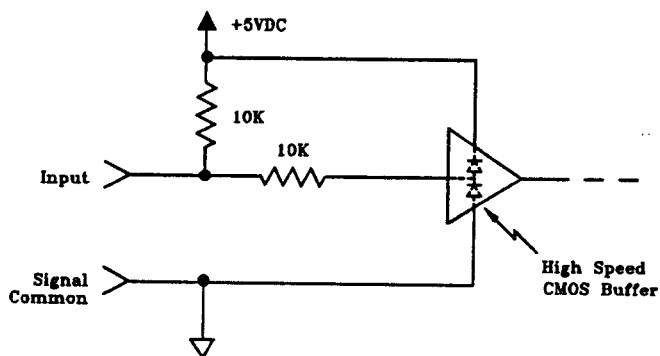

All inputs are protected against accidental overvoltage of ± 30 volts. These inputs will accept dry contact, open collector, TTL and 5 to 15 volts CMOS.

The circuit configuration below illustrates all outputs described in section 2-3, A, B and C.

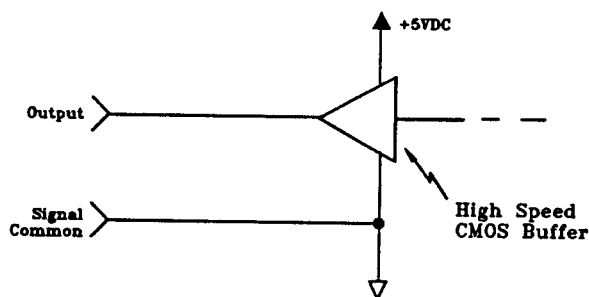

Maximum current sourcing	+20mA
Maximum current sinking	-20mA
Unloaded logic levels	+5 VDC logic high 0 VDC logic low
Loaded logic levels (@ ±5 mA sourcing or sinking)	+4.8 VDC logic high +.18 VDC logic low

SECTION 2-4 INPUT/OUTPUT INTERFACE CONNECTOR

Connector J5 provides the means for terminating the input (I1,I2,I3,I4) and output (O1,O2,O3,O4) interface connections described in Part II, section 2-2I of the *Unidex 11 Motion Controller Programming Manual*.

This receptacle also provides termination for the feedhold input described in item I of section 2-2 of the programming manual.

Figure 2-4 shows the outline of this receptacle.

Pin #	Description
1	Shield
5	Input 1 (I1)
12	Input 2 (I2)
4	Input 3 (I3)
11	Input 4 (I4)
3	Output 1 (O1)
10	Output 2 (O2)
2	Output 3 (O3)
9	Output 4 (O4)
13	Feedhold
6,7,8,14,15	Signal common

Electrical specifications for inputs I1 through I4 are listed below:

Maximum input voltage: 0 to +5.0 VDC
Maximum input lo current (VIN = +.4 VDC): -2.4mA
Maximum input hi current (VIN = +2.4 VDC): +.4mA

These inputs are designed to accept TTL, +5 CMOS open collector drivers.

NOTE: These inputs are unbuffered. Dry contact inputs are *not* recommended. Interconnection wiring greater than 5 feet is not recommended. Electrical specifications for output O1 through O4 is listed below.

Electrical Specifications for Output O1 through O4 is listed below:

Minimum output high voltage = 2.4 volts (Iload = +2mA)
4.0 volts (Iload = +10 μ A)

Maximum output low voltage = .4 volts (Iload = -3.2mA)

NOTE: These outputs are unbuffered. Driving interface is limited to two TTL or 5 volt CMOS only. Interconnection wiring greater than 5 feet is not recommended.

The circuit configuration for the feedhold input is shown below:

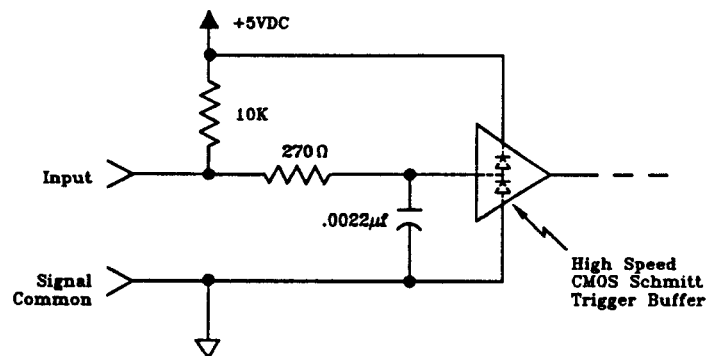

The feedhold input is protected against accidental overvoltage of ± 30 volts. Logic inputs such as dry contact, open collector, TTL and 5 to 15 volt CMOS can be used.

SECTION 2-5 OPTO-INTERFACE CONNECTOR

The opto-interface connector, J6, is designed to accept Opto-22 PB8, PB16A or C and PB24 input/output module boards. (Consult Opto-22 data book for additional information.) Input and output modules for the Opto-22 board come in a variety of configurations for optically isolating the control (in this case, Unidex 11) to various levels of AC and DC voltages. These input and output modules are, in essence, optically isolated solid state switches.

An optional ribbon cable and connector assembly (OPC) can be supplied by Aerotech (5 feet in length) to interface the Unidex 11 (through receptacle J6) directly to the PB8, PB16A or C, or PB24 I/O Board. All necessary voltages and connections are supplied in the cable. The user need only make the appropriate field connections to the optically isolated side of the board through an integral barrier, screw terminal strip.

Some important items to note when using the opto-interface option are as follows:

1. The zero (axis "in position") connection (Pin 4) of the X, Y auxiliary control receptacles (section 2-3C) *cannot* be used when using module positions 9 & 12 of the PB16 A or C and PB24 boards.
2. The Unidex 11 *must* be configured for the form A and form B limit input mode (*not* form C—see section 2-2 of this manual), in order to alternatively connect the CW and CCW limit connections through the Opto-22 Isolation board. Since the home limit connection is not available at the J6 connector, the appropriate drive board *must* be reconfigured to handle this situation. See appropriate drive card in chapter 4.

If CW and CCW limits are brought in through receptacles J13, J14, J19 and J20 (section 2-2), module positions 10, 11, 13, 14, 18, 19, 21 and 22 on the PB16 A or C or PB24 I/O boards must not be used.

3. Input (I1 through I4), output (O1 through O4) and feedhold connections on receptacle J5, Input/Output (section 2-4) cannot be used if the associated module positions 0 through 8 on the I/O board are used.

WARNING: Neglecting the conditions stated above may cause excessive loading and/or damage to the Unidex 11.

An interconnection diagram of the PB8, PB16A or C, or PB24 I/O board connected through J6 is shown in table 2-2.

Input, output and feedhold characteristics (module position 0 through 8) are the same as that described in section 2-4. (Logic low on output of Unidex 11 activates output modules. When input modules are energized, Unidex 11 will read it as logic low.)

CW limit and CCW limit characteristics (module positions 10, 11, 13, 14, 18, 19, 21 and 22) are the same as those described in section 2-2). (When input modules are energized, Unidex 11 will read it as logic low.)

Zero (module positions 9, 12, 17 and 20) is an "in-position" indication. At the output of Unidex 11, this signal is a logic high when using any stepping motor drive. It is a logic low when using a DC servo drive (DSL8020). Logic low on outputs of Unidex 11 activates output modules.

Reset (module position 15) is a programmable, active low, output (logic low on outputs of Unidex 11 activate output modules). See the following sections of the *Unidex 11 Motion Controller Programming Manual*: section 2-2M of Part II, and section 5-1D and 5-1AA of Part IV.

Local/Remote (module position 16) is an output indicating the local or remote modes of operation (see section 2-2M of Part II of the *Unidex 11 Motion Controller Programming Manual*, or section 2-2A, Part II of the *Unidex 11 Motion Controller Options Manual*). Local mode is indicated by a logic low and remote mode is indicated by a logic high (logic low on the outputs of Unidex 11 activates output modules).

Consult Opto 22 for additional information.

SECTION 2-6 JOYSTICK INTERFACE CONNECTOR

The joystick connection is made at receptacle J3 of the interface board. *Unidex 11 Motion Controller Programming Manual*, section 2-2H of Part II, describes in detail the characteristics of the joystick.

The joystick is made by CH Products and is modified by Aerotech to Unidex 11 specifications. An integral 15 pin "D" connector and cable is supplied with the joystick.

WARNING: Use of other CH Products' Joysticks with similar connectors may damage the Unidex 11.

When referring to the above mentioned section of the *Unidex 11 Motion Controller Programming Manual*, note the null offset adjustment knobs of the joystick. Typically, these adjustments are factory set. However, when in the joystick tracking screens (denoted by "jk"), if any of the axes is "drifting" in position when the stick is centered, do the following:

- Power down and temporarily remove the stepping motor power connections (XJ1, YJ1, UJ1 and VJ1).

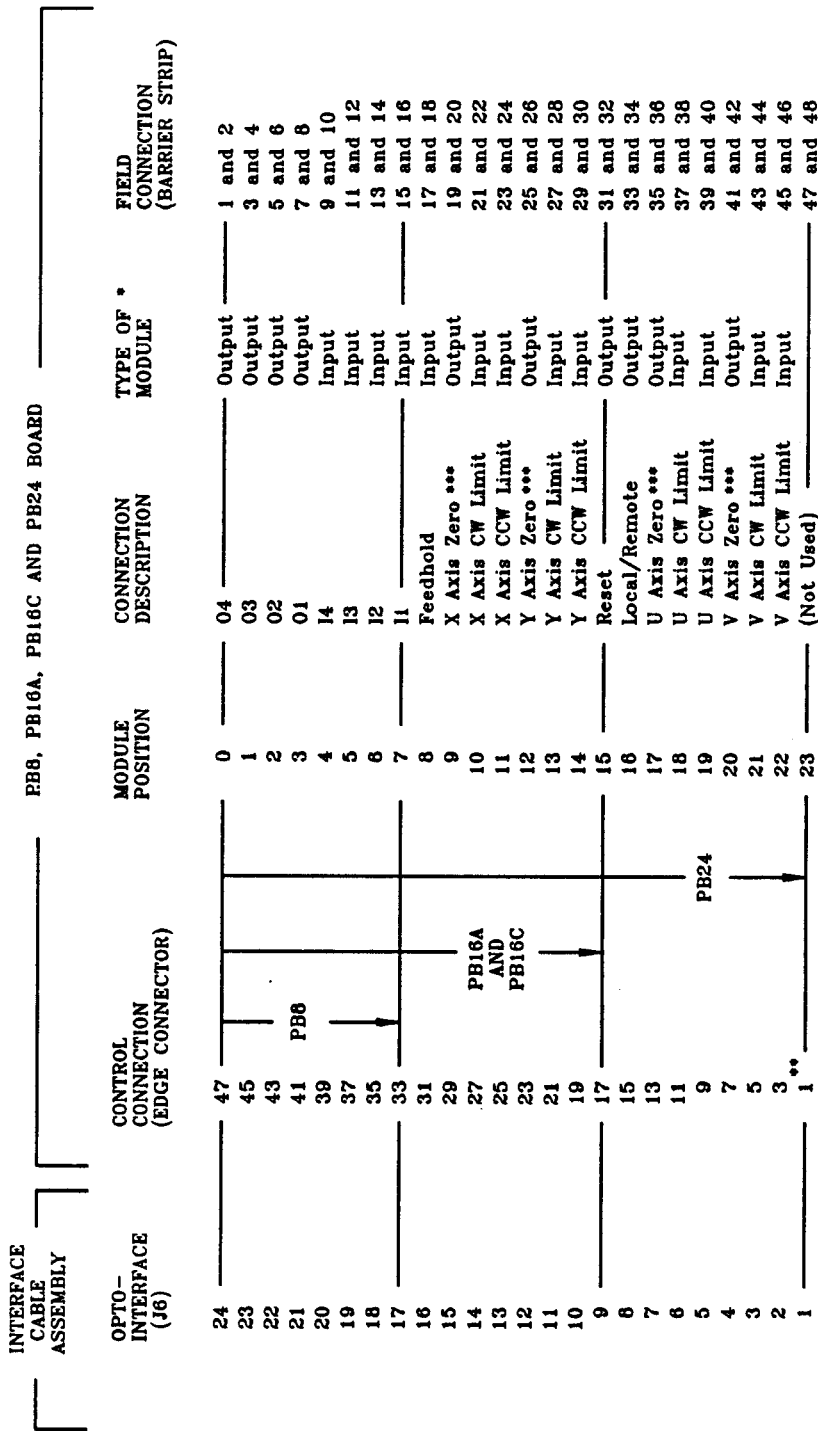

* WARNING: Type of module (input or output) cannot be interchanged. To do so may damage Unidex 11.

** Additional +5 volt connection on Pin 1, PB8, PB16A and PB16C is not used on PB24.

*** Polarities of "Zero" signal are opposite for stepping motor controls and DC servo controls.

Pin 1 & 25 are +5VDC.
 Pins 26 through 50 are signal common.
 Pin 49 is +5VDC.
 All even pins (2 to 50) are signal common.

Table 2-2: Interconnection Diagram of PB8, PB16A or C, or PB24 I/O Board

- Return to the joystick tracking screens (a "default" frequency divisor of 20 should be sufficient).
- Adjust the appropriate null offset knobs on the joystick until the joystick tracking display for that axis stops counting. (A "dead band" region exists between minus and plus counting directions. Adjust to the "middle" of this region.)
- Reconnect the stepping motor power connections.

Refer to the above mentioned section of the *Unidex 11 Motion Controller Programming Manual* for further information on the joystick option.

SECTION 2-7 RS-232 INTERFACE CONNECTOR

Connector J2 provides for the termination of the RS-232 communication interface.

An outline of this receptacle is shown in figure 2-4.

See Part IV of the *Unidex 11 Motion Controller Programming Manual* for more information on RS-232.

SECTION 2-8 IEEE-488 INTERFACE CONNECTOR

Connector J15 provides for the termination of the IEEE-488 communications interface.

An outline of the receptacle is shown in figure 2-4.

See Part I of the *Unidex 11 Motion Controller Options Manual* for more information on IEEE-488.

SECTION 2-9 DIGITAL I/O PORT & TDT THUMBWHEEL

Connector J21 allows the user to output 12 bit information (0 to 4095 binary, or 0 to 999 BCD) through manual or program control. A strobe is also included as an aid in interfacing with other controllers.

This receptacle can also be used as an input for calling up 0 through 99 (BCD) programs to be executed by Unidex 11. The input mode can be used directly or can be interfaced to the Aerotech TDT "Thumbwheel" option. See Part IV of the *Unidex 11 Motion Controller Options Manual* for more information concerning the Digital I/O Port and the TDT Thumbwheel Option. An outline of this receptacle is shown in figure 2-4.

SECTION 2-10 HIGH SPEED BINARY INTERFACE

Connector J24 is used for interfacing to another Unidex 11 control option, the High Speed Binary interface. For more information on this option, see Part V of the Options manual.

An outline of this receptacle is shown in figure 2-4.

SECTION 2-11 SERIAL OUTPUT (SEO) INTERFACE

The Serial Output Interface (SEO) provides opto isolated (standard) or TTL/CMOS (optional) position information for external use (such as position counters/displays and speed indicators). Each SEO board (figure 2-5) provides outputs for two axes, so two SEO boards are required for three- or four-axis applications. Outputs are present on the chassis rear panel at connectors J22 (X and Y axis) and J23 (U and V axis). See figure 2-4 for an outline of these connectors.

The outputs present at J22 and J23 vary for stepping motor drives (D, DM, DMV Series) as opposed to DC servo motor drives (DSL Series). In addition, certain output variations and polarity inversions are possible within each subdivision. For J22/J23 outputs when stepping motor drives are being used, see table 2-3. For J22/J23 outputs when DC servo motor drives are being used, see table 2-4. Note that each table indicates the standard output functions, as well as applicable jumper information needed to change to certain optional output functions. Figure 2-6 shows the typical "electronics" for each available output.

The output signals for stepping motor drives are clock, direction and /marker or /reset. (Note that a slash (/) indicates active low outputs, and no slash indicates active high.) The output signals for DC servo motor drives are CW clock, CCW clock and /marker or /reset. The /marker signal is standard for both types of drives and the /reset signal is optional. The following is a brief definition of each output.

- | | |
|-------------------------|---|
| 1. Clock - | This output is a mirror of the axis command clock. Each pulse represents one commanded step. |
| 2. Direction - | This output is a mirror of the axis command direction. Logic high (+5VDC) indicates CW motor rotation, logic low (0VDC) indicates CCW motor rotation. |
| 3. /Marker (standard) - | This output mirrors the system feedback reference pulse. |

- 4. /Reset (optional) - This output indicates axis "reset" status.
- 5. CW Clock - This output is a 1 μ Sec pulse that is derived from the encoder feedback signal when the servo motor is rotating in the CW direction. Each pulse represents one commanded machine step.
- 6. CCW Clock - Same as CW clock except that it is produced by opposite direction motor rotation.

NOTE: All cables interfacing to the SEO outputs should be limited in length to 15 ft. If longer cables are required, please consult factory for SEO modifications.

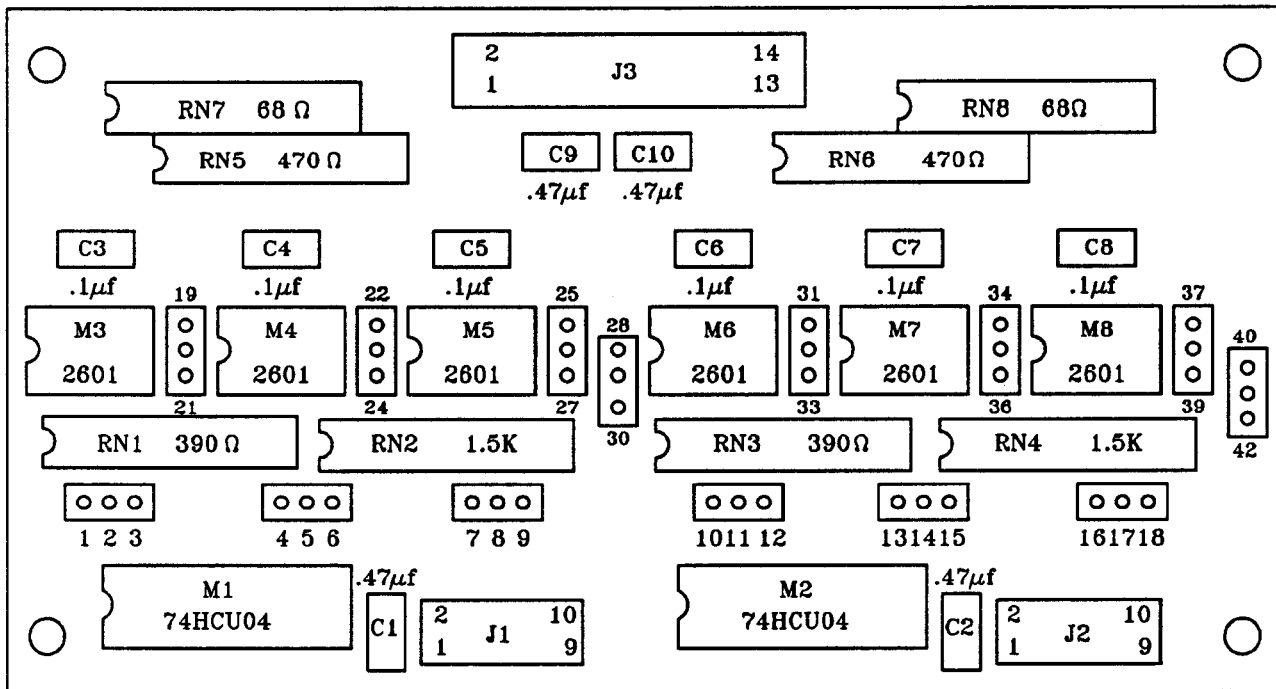

Figure 2-5: SEO Interface Board, 690C1353

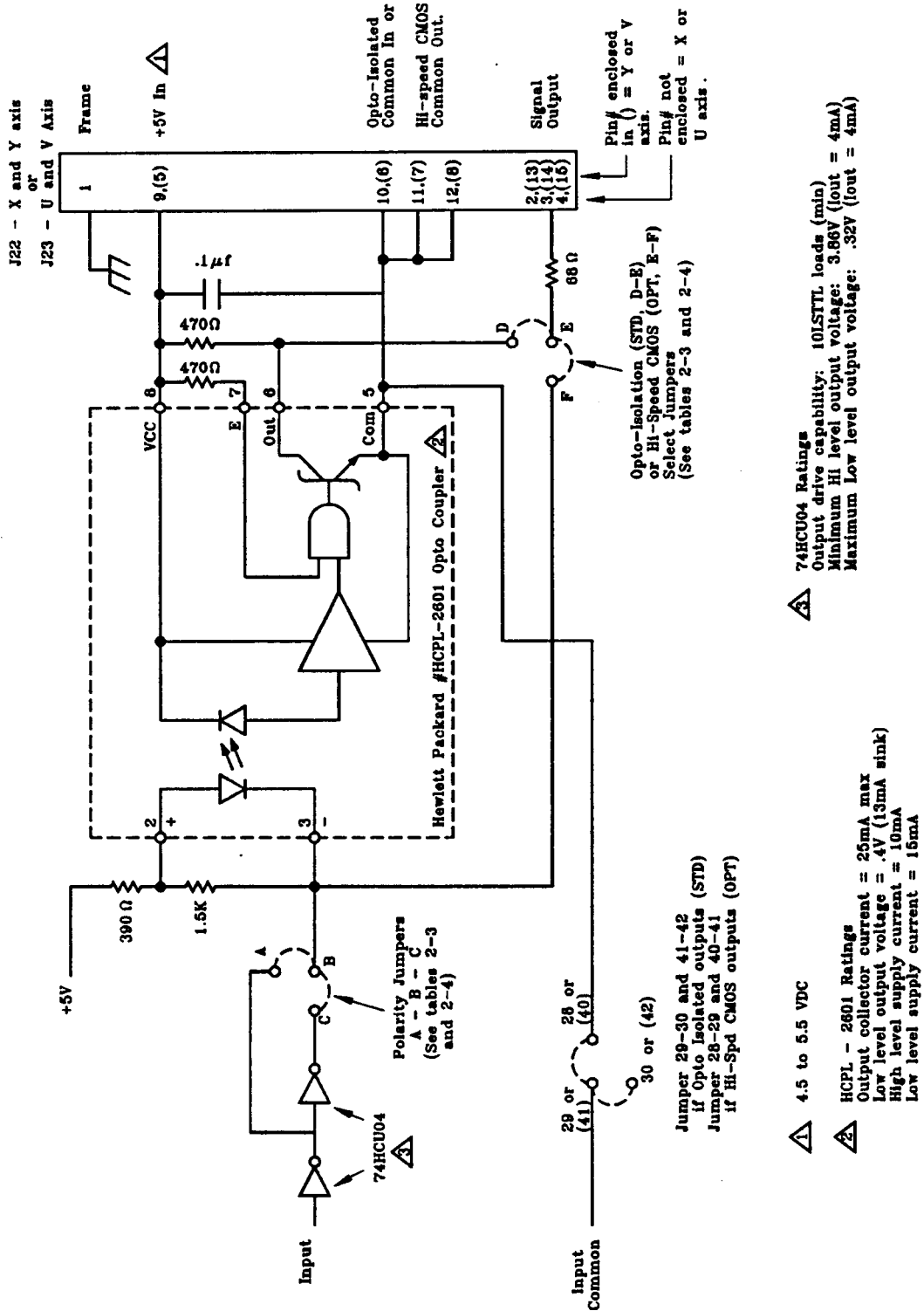

Figure 2-6: Typical "SEO" Output Circuit

J22-X,Y (J23-U,V) Pin #	Standard Output Function	Standard Output Function, Polarity Jumper A - B - C	Optional Output Function	Optional Output Function, Polarity Jumper A - B - C	Opto Isolation Select (STD) ² Jumper D - E - F	Hi-Speed C-MOS Select (Optional) ³ Jumper D - E - F
1	Shield	N.A.	Shield	N.A.	N.A.	N.A.
9	X(U)+5VDC In	N.A.	X(U)+5VDC In	N.A.	N.A.	N.A.
10,11,12	X(U) Com	N.A.	X(U) Com	N.A.	N.A.	N.A.
2	X(U) Clock	1-2-3	X(U) /Clock	1-2-3	19-20-21	19-20-21
3	X(U) Dir	4-5-6	X(U) /Dir	4-5-6	22-23-24	22-23-24
4	X(U)/Marker or ⁴	7-8-9	X(U) Marker or ⁴	7-8-9	25-26-27	25-26-27
5	X(U)/Reset	7-8-9	X(U) Reset	7-8-9	25-26-27	25-26-27
6,7,8	Y(V)+5VDC In	N.A.	Y(V)+5VDC In	N.A.	N.A.	N.A.
	Y(V) Com	N.A.	Y(V) Com	N.A.	N.A.	N.A.
13	Y(V) Clock	10-11-12	Y(V) /Clock	10-11-12	31-32-33	31-32-33
14	Y(V) Dir	13-14-15	Y(V) /Dir	13-14-15	34-35-36	34-35-36
15	Y(V)/Marker or ⁴	16-17-18	Y(V) Marker or ⁴	16-17-18	37-38-39	37-38-39
	Y(V)/Reset	16-17-18	Y(V) Reset	16-17-18	37-38-39	37-38-39

- NOTES:
- 1 /Output = Active low (0V), Output = Active high (+5VDC).
 - ² If opto isolators are used, add jumpers 29-30, 41-42. See figure 2-6.
 - ³ If hi-speed CMOS, add jumpers 28-29, 40-41. See figure 2-6.
 - ⁴ A third output (per axis) can be "/Marker" or "/Reset". This is not field changeable. Output must be configured at factory. "/Marker" output is standard unless specified otherwise.

Table 2-3: Stepping Motor Drive-J22,J23 Output Definitions and Options

J22-X,Y (J23-U,V) Pin #	Standard Output Function	Standard Output Polarity Jumper A - B - C	Optional Output Function	Optional Output Polarity Jumper A - B - C	Opto Isolation Select (STD) Jumper D - E - F	Hi-Speed C-MOS Select (Optional) Jumper D - E - F
1	Shield	N.A.	Shield	N.A.	N.A.	N.A.
9	X(U)+5VDC In	N.A.	X(U)+5VDC In	N.A.	N.A.	N.A.
10,11,12	X(U) Com	N.A.	X(U) Com	N.A.	N.A.	N.A.
2	X(U) CW CLK	1-2-3	X(U) /CW CLK	1-2-3	19-20-21	19-20-21
3	X(U) CCW CLK	4-5-6	X(U)/CCW CLK	4-5-6	22-23-24	22-23-24
4	X(U)/Marker or \triangle	7-8-9	X(U) Marker or \triangle	7-8-9	25-26-27	25-26-27
5	X(U)/Reset	7-8-9	X(U) Reset	7-8-9	25-26-27	25-26-27
6,7,8	Y(V)+5VDC In	N.A.	Y(V)+5VDC In	N.A.	N.A.	N.A.
	Y(V) Com	N.A.	Y(V) Com	N.A.	N.A.	N.A.
13	Y(V) CW CLK	10-11-12	Y(V) /CW CLK	10-11-12	31-32-33	31-32-33
14	Y(V)CCW CLK	13-14-15	Y(V)/CCW CLK	13-14-15	34-35-36	34-35-36
15	Y(V)/Marker or \triangle	16-17-18	Y(V) Marker or \triangle	16-17-18	37-38-39	37-38-39
	Y(V)/Reset	16-17-18	Y(V) Reset	16-17-18	37-38-39	37-38-39

NOTES: 1 /Output = Active low (0V), Output = Active high (+5VDC).
 2 If opto isolators are used, add jumpers 29-30, 41-42. See figure 2-6.
 3 If hi-speed CMOS, add jumpers 28-29, 40-41. See figure 2-6.
 4 A third output (per axis) can be "/Marker" or "/Reset". This is not field changeable. Output must be configured at factory. "/Marker" output is standard unless specified otherwise.

Table 2-4: DC Servo Motor Drive-J22,J23 Output Definitions and Options

SECTION 2-12 UNIDEX 11 POWER CONNECTIONS

Input power to the Unidex 11 involves only a single 115 or 230VAC 50/60Hz input connection (see figures 2-1, 2-2 and 2-3) at the rear of the Unidex 11 chassis (figure 2-11 shows a detailed outline of this connection).

Motor output connections (up to four, depending on the type of chassis) consists of either stepping motor or DC servo motor termination. Two types of motor output receptacles are used, depending on the Unidex 11 chassis style (i.e., U11S, U11R, U11M or U11H). An outline of these receptacles is shown in figure 2-7.

Motor terminations to the receptacles shown in figure 2-7 are of three types, two for stepping motor operation, and one for DC motor operation. Stepping motor termination can be of either "bipolar"

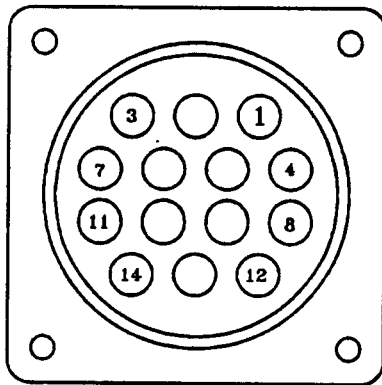

14 Pin Plastic Style *
(Standard for U11M,
U11S and U11R Chassis)

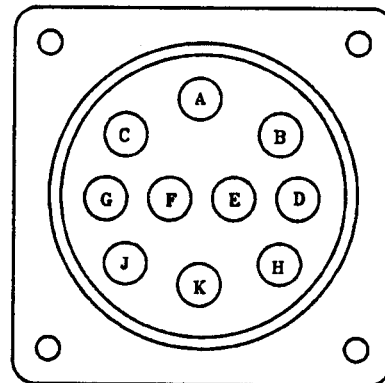

10 Pin Metal Style *
(Standard for U11H Chassis,
Optional for U11M, U11S and
U11R Chassis)

* See also figures 2-8, 2-9 and 2-10

Figure 2-7: Motor Output Receptacles at Rear of Unidex 11 Chassis

wound or "unipolar" wound, as shown in figures 2-6 and 2-7 respectively. DC servo motor termination is shown in figure 2-8.

It should be noted that if the Unidex 11 is supplied with Aerotech motors and cables, you need not concern yourself with the detailed wiring termination shown in figures 2-8, 2-9, 2-10 and 2-11.

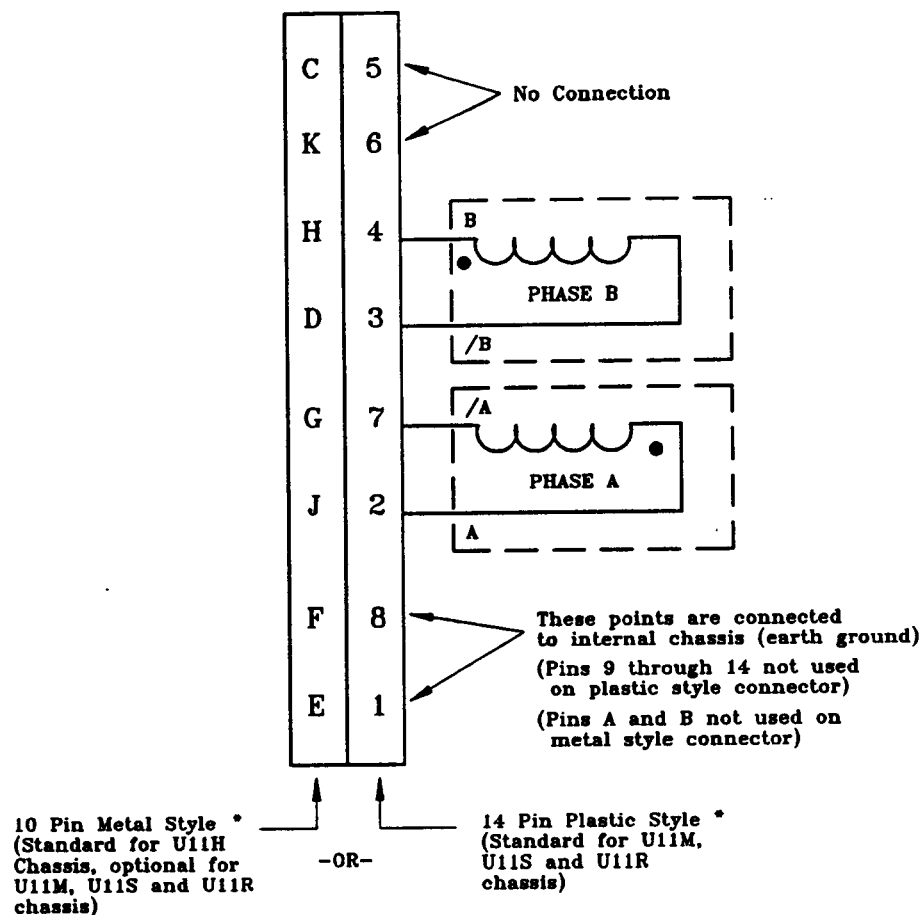
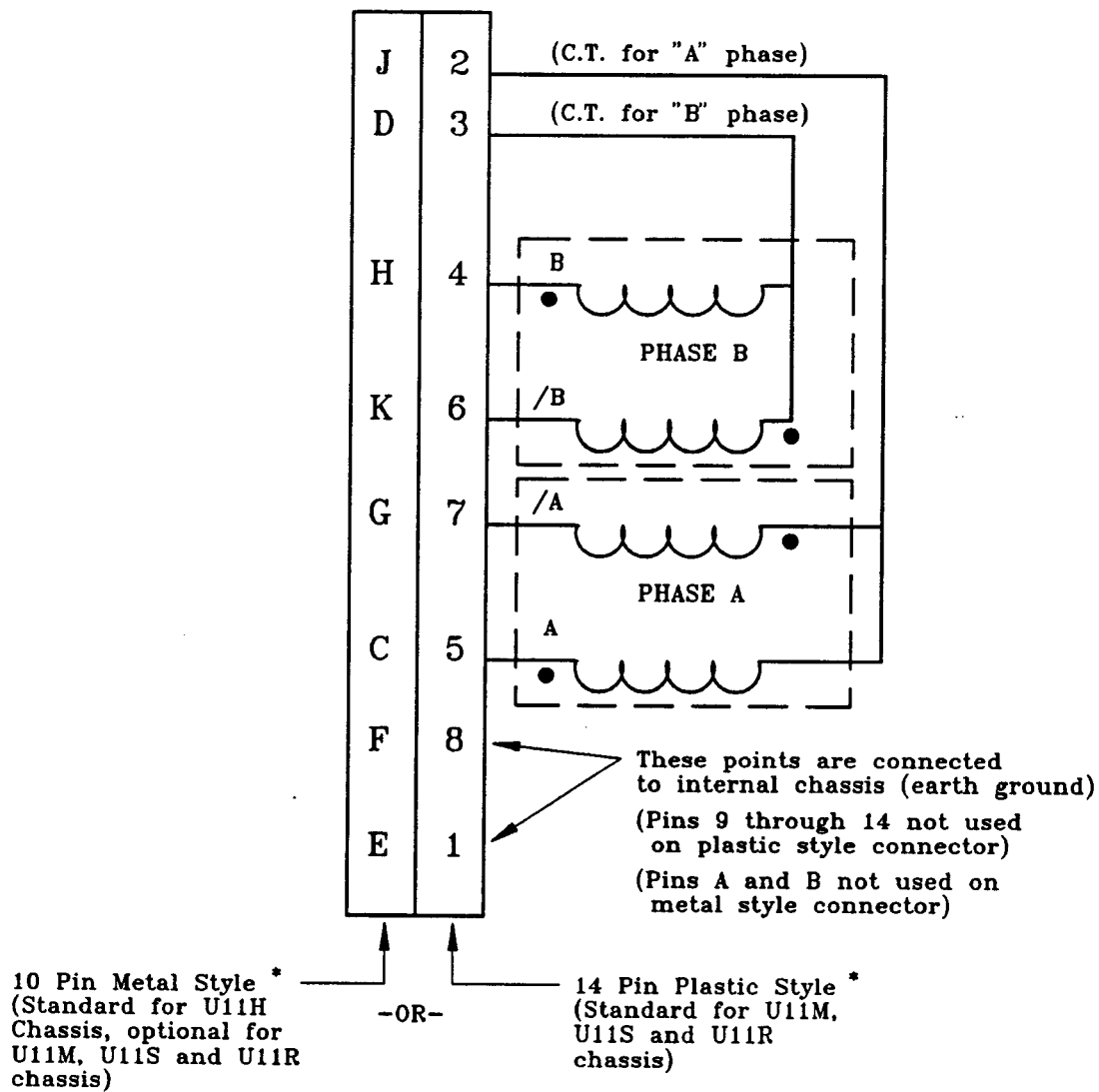

Figure 2-8: Outline of Connections for "Bipolar" Wound Stepping Motor



* See also figure 2-7

Figure 2-9: Outline of Connections for "Unipolar" Wound Stepping Motor

CHAPTER 2: UNIDEX 11 REAR PANEL CONNECTIONS

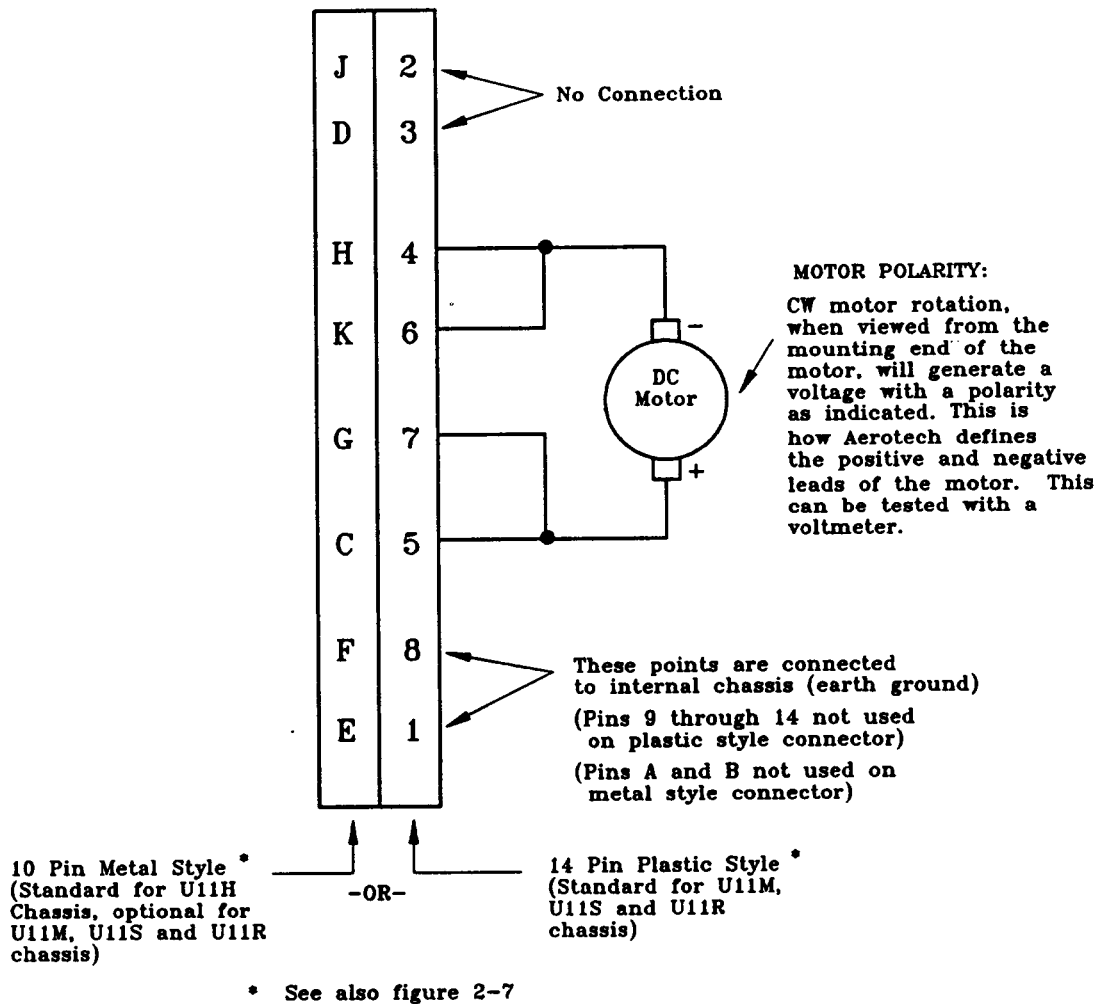

Figure 2-10: Outline of Connections for "Brush" Type DC Servo Motor

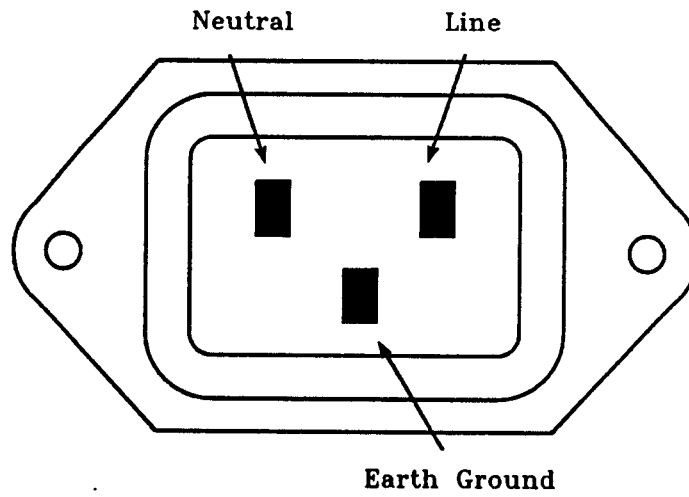

Figure 2-11: Outline of Input Power Receptacle at the Rear of Unidex 11 Chassis

CHAPTER 3: INTERNAL STRUCTURE OF UNIDEX 11

This chapter discusses briefly the internal hardware and drive module organization of the Unidex 11 U11S, U11R, U11H and U11M chassis. This section contains general information regarding the placement into a given chassis of stepping and/or DC servo drive modules (described in chapter 4). Information on power interconnect wiring for the drive modules in the chassis is also provided.

A simplified wiring diagram of the U11S and U11R is shown in figure 3-1. An accompanying outline of these chassis with front panel removed is shown in figure 3-4. A simplified wiring diagram of the U11H chassis is shown in figure 3-2 with an accompanying outline shown in figure 3-5 (top cover removed). Finally, a simplified wiring diagram of the U11M chassis is shown in figure 3-3 with its outline shown in figure 3-6 (top cover removed).

The internal organization is very similar for the U11S, U11R and U11H chassis. All three configurations allow both DC servo and stepping motor control, using the appropriate drive modules. The U11M configuration allows only low power stepping motor control.

The U11H configuration differs electrically from the U11S and U11R only in total motor output power capability. For example, for DC motor operation using the DSL8020 drive module, the U11H chassis can be configured to provide a total of 1500 watts of continuous output power distributed among all four axis. The U11S and U11R chassis can only provide a maximum of about 750 watts distributed among all four axis.

The U11S, U11R and U11H chassis provide a DC bus power supply for high power stepping motor operation (using the DMV8008 and DMV16008) and DC servo motor operation (using the DSL8020). The low power stepping drive modules (D and DM Series) can be used in these chassis without the need for a DC bus power supply (i.e., these modules generate control and bus power for the motor internally).

The U11M chassis cannot be supplied with a DC bus power supply and this is applicable only to the low power stepping drive modules of the D and DM Series.

NOTE: One axis of DM6006 can be provided in the U11M chassis upon request.

The DC bus power supply for the U11S, U11R and U11H chassis (see figures 3-1 and 3-2) can be configured for a variety of DC voltage levels for use with the DMV8008, DMV16008 and DSL8020 drive modules. The possible DC bus voltage levels for a given chassis is as follows:

U11S AND U11R CHASSIS:

DC BUS VOLTAGE	AXIS DISTRIBUTION
20VDC	All axes; X,Y,U; Y,U,V; X,Y; U,V axes
40VDC	All axes, X,Y,U; Y,U,V; X,Y; U,V axes
60VDC	All axes only
80VDC	All axes only

U11H CHASSIS:

DC BUS VOLTAGE	AXIS DISTRIBUTION
20VDC**	All axes, any single axis, or any axes group
40VDC**	All axes, any single axis, or any axes group
60VDC**	All axes, any single axis, or any axes group
80VDC**	All axes, any single axis, or any axes group
100VDC *	All axes only
120VDC *	All axes only
140VDC *	All axes only
160VDC *	All axes only

* These voltages are applicable to DMV16008 operation only. 160VDC operation can be derived "off-line" (US/Domestic 115VAC line) without the use of transformer T1 or T2.

** Some combinations are only possible with 2 transformers (1500W option, 2P11-xxx).

The secondary side of transformer T1 (and T2) provides the necessary AC voltage to be rectified to DC (see figures 3-1 and 3-2).

The individual secondary windings A0-A14-A28, B0-B14-B28, etc., each supply up to 28VAC centertap voltages (A14, B14, etc. are the centertap connection).

Jumper connections on the Unidex 11 motherboard (JP1, JP2, JP3, etc.) provide "connect/disconnect" points to the given axis for the selected DC bus voltages supplied by capacitors C1 through C4.

IMPORTANT NOTE: The drive module slots (P1 - P4, see figures 3-1, 3-2, 3-4 and 3-5) are electrically interconnected so that damage will *NOT* occur to a given module or motor (if, for example, a stepping drive module is inadvertently plugged into a slot setup for DC servo operation). Nevertheless, *special care should be taken when removing the drive modules from the Unidex 11 chassis.*

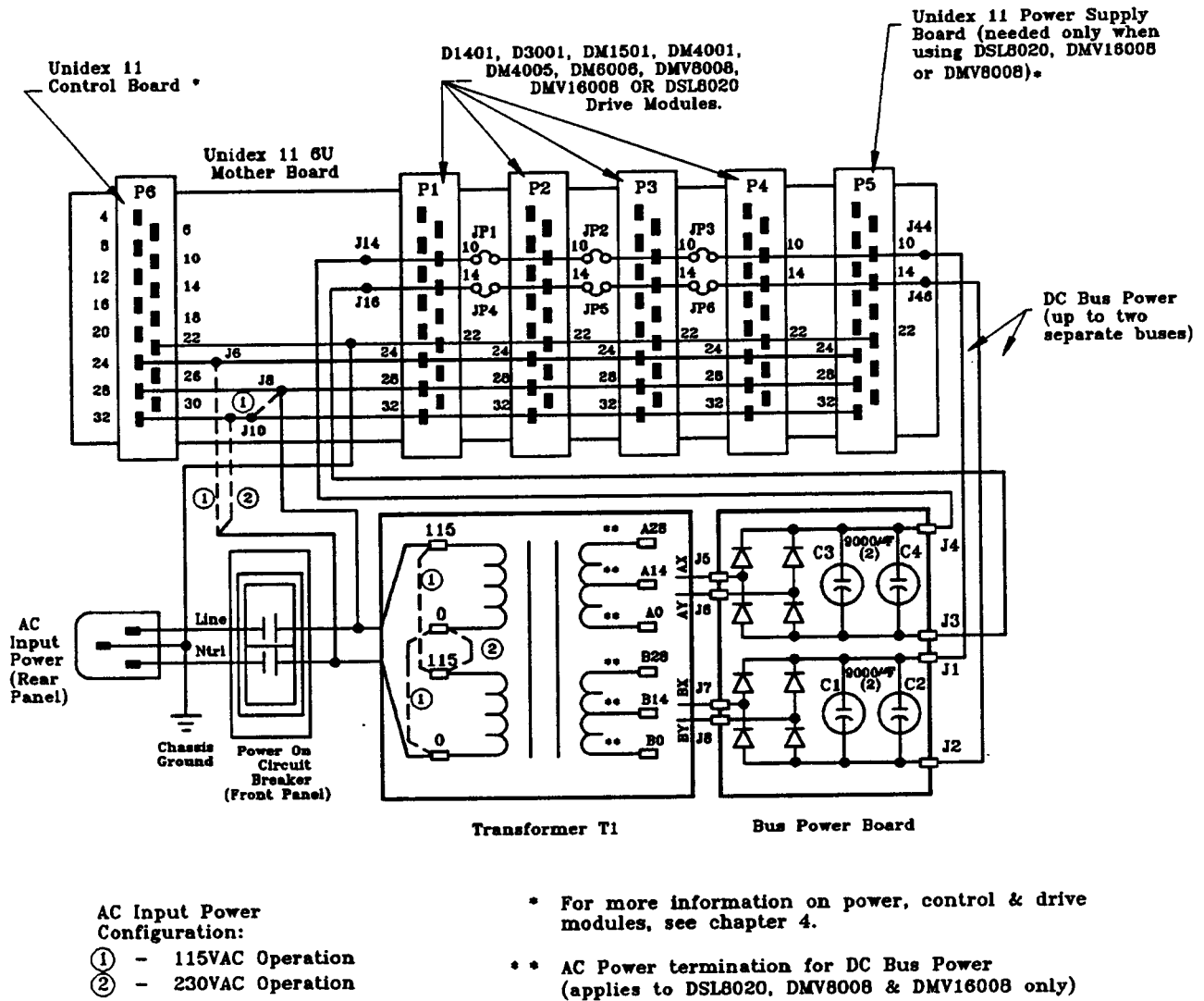

Figure 3-1: Simplified Wiring Diagram of U11S & U11R Chassis with Front Panel Removed (see Figure 3-4 for Outline)

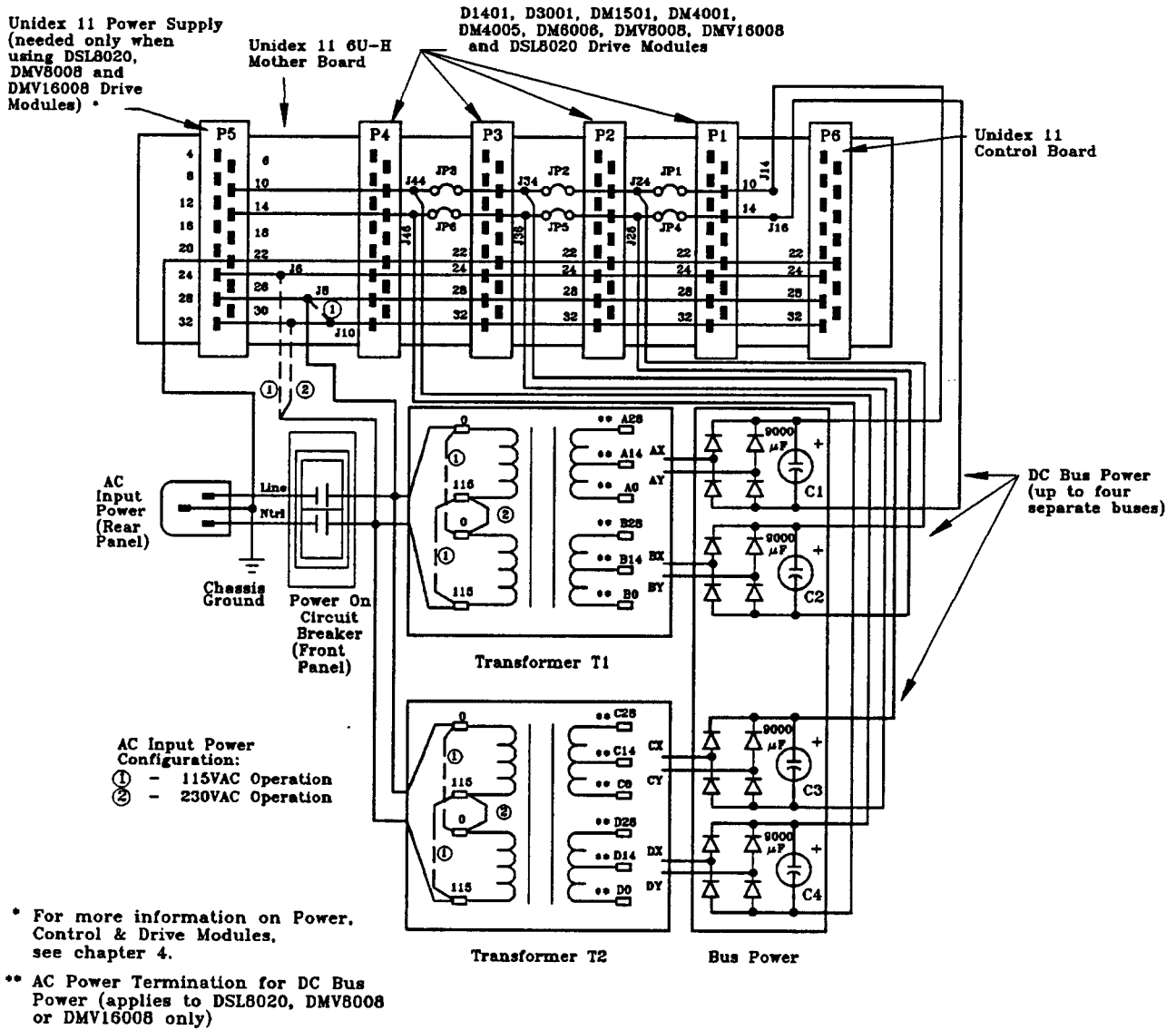

Figure 3-2: Simplified Wiring Diagram of the U11H Chassis with Top Cover Removed (See Figure 3-5 for Outline)

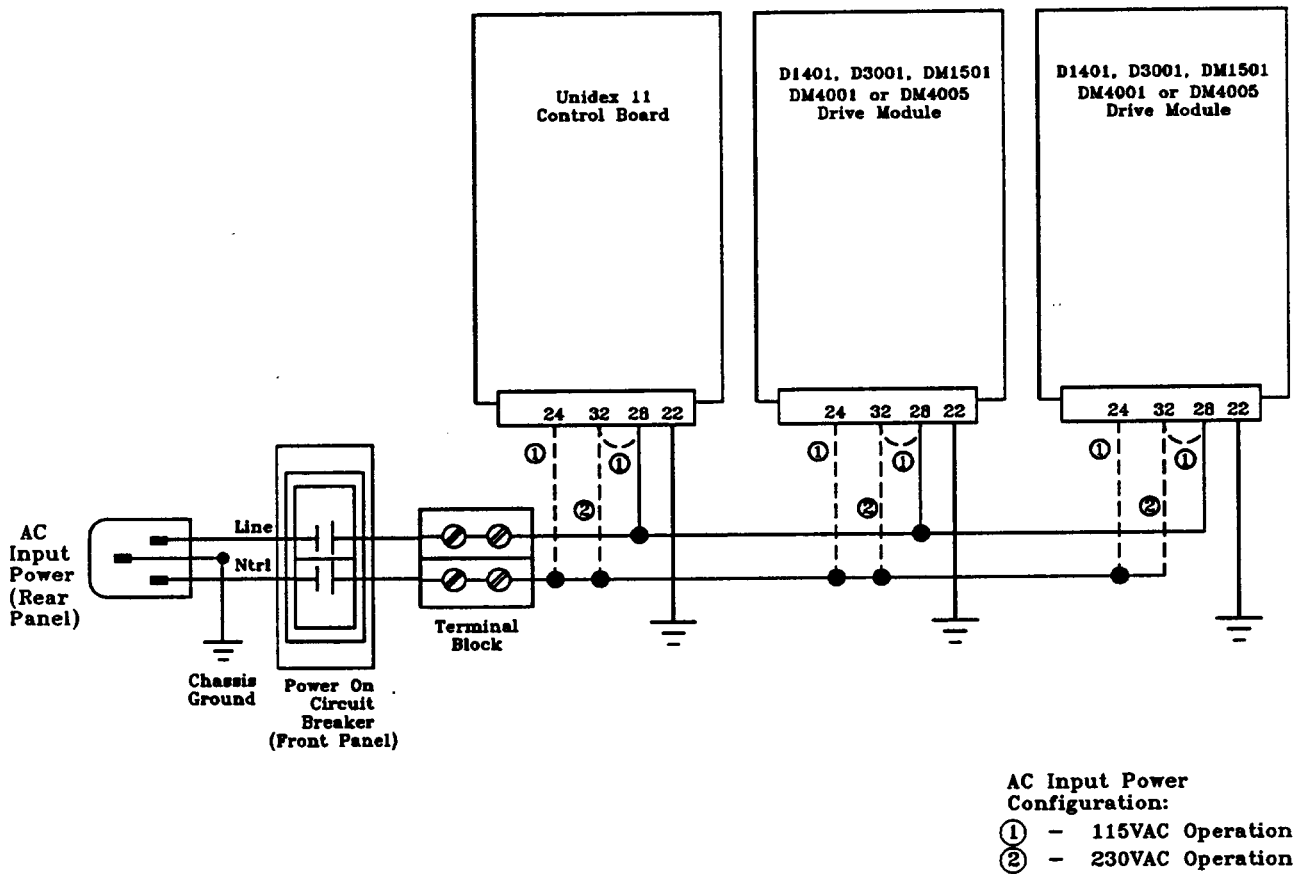

Figure 3-3: Simplified Wiring Diagram of the U11M Chassis with Top Cover Removed (See Figure 3-6 for Outline)

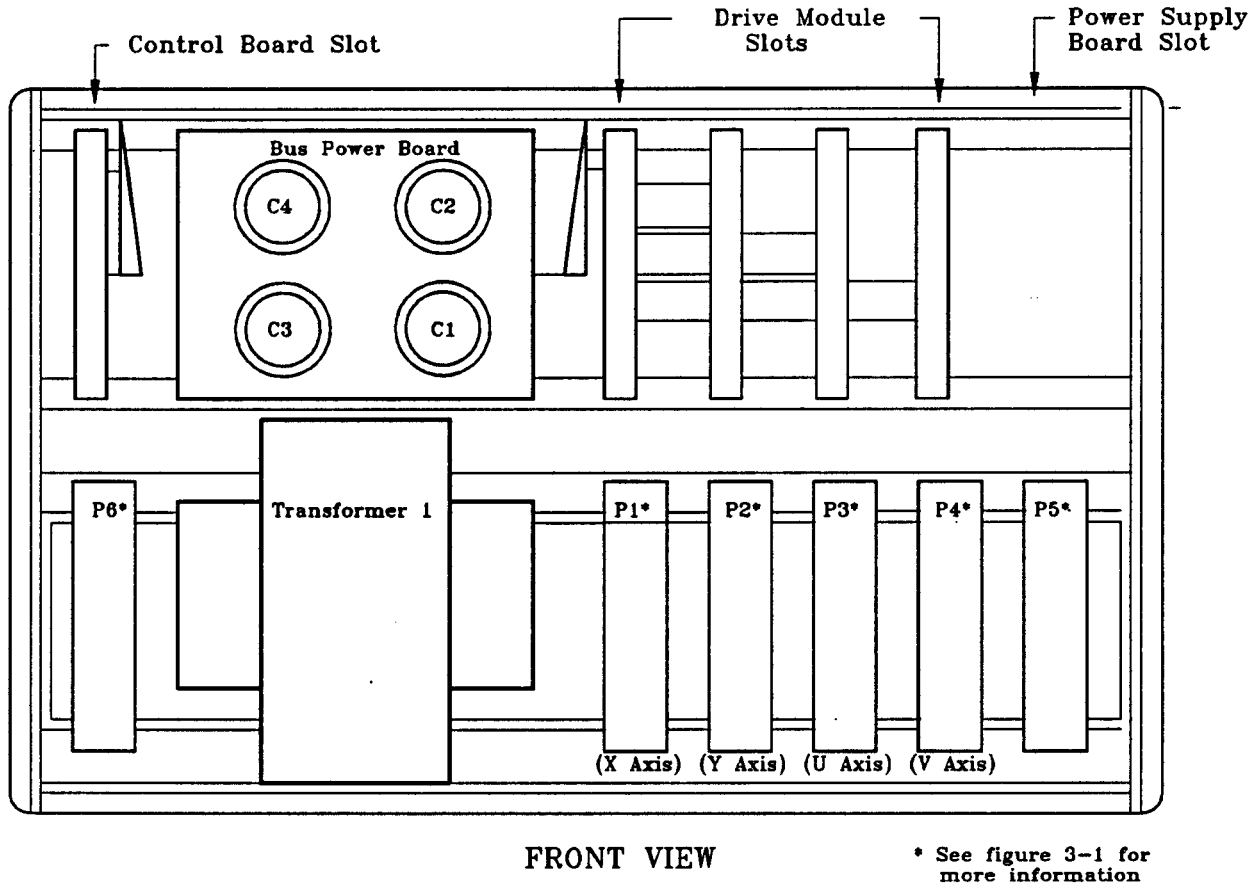
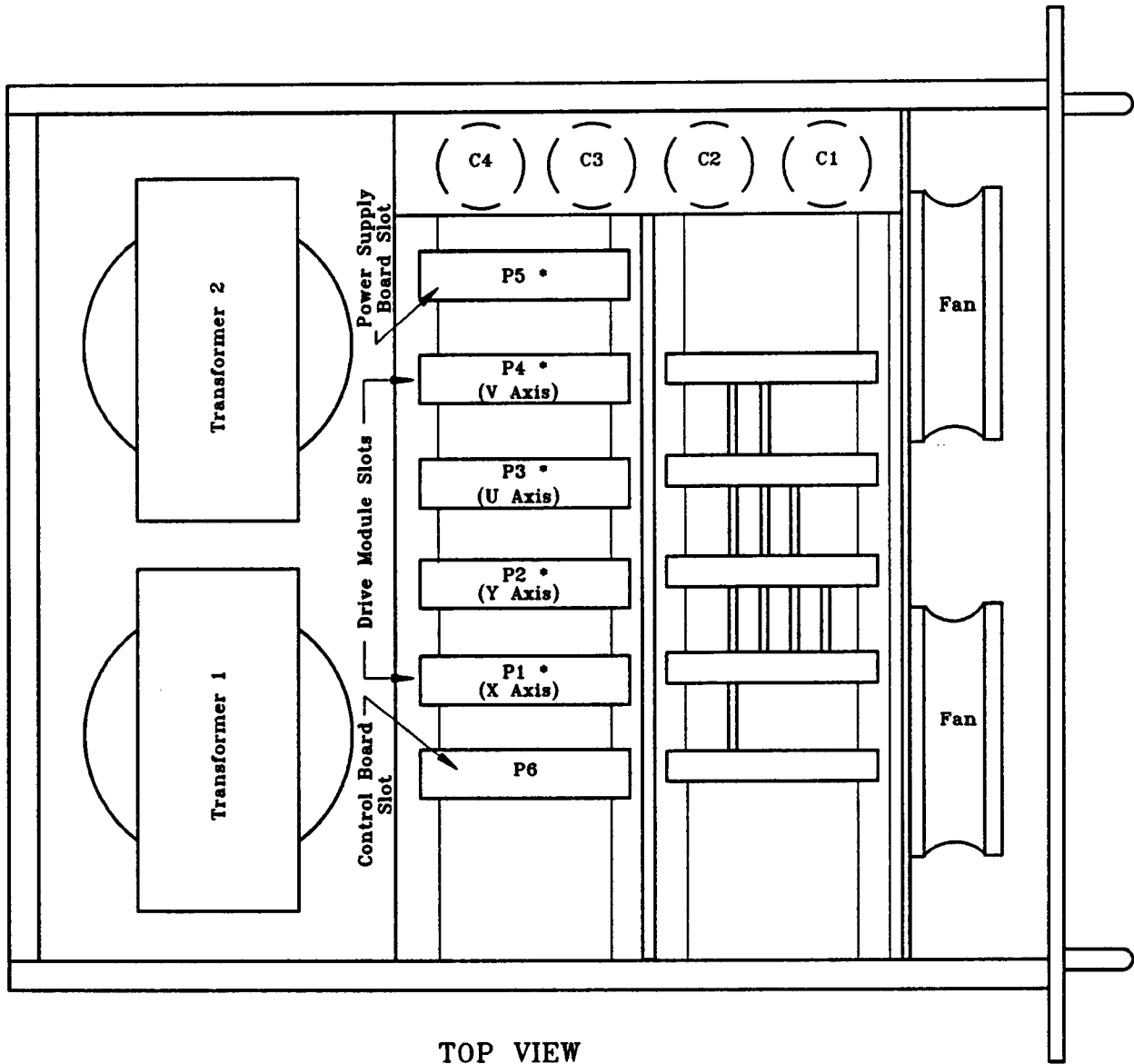

Figure 3-4: Outline of the U11S and U11R Chassis with Front Panel Removed



* See figure 3-2 for more information.

Figure 3-5: Outline of U11H Chassis with Top Cover Removed

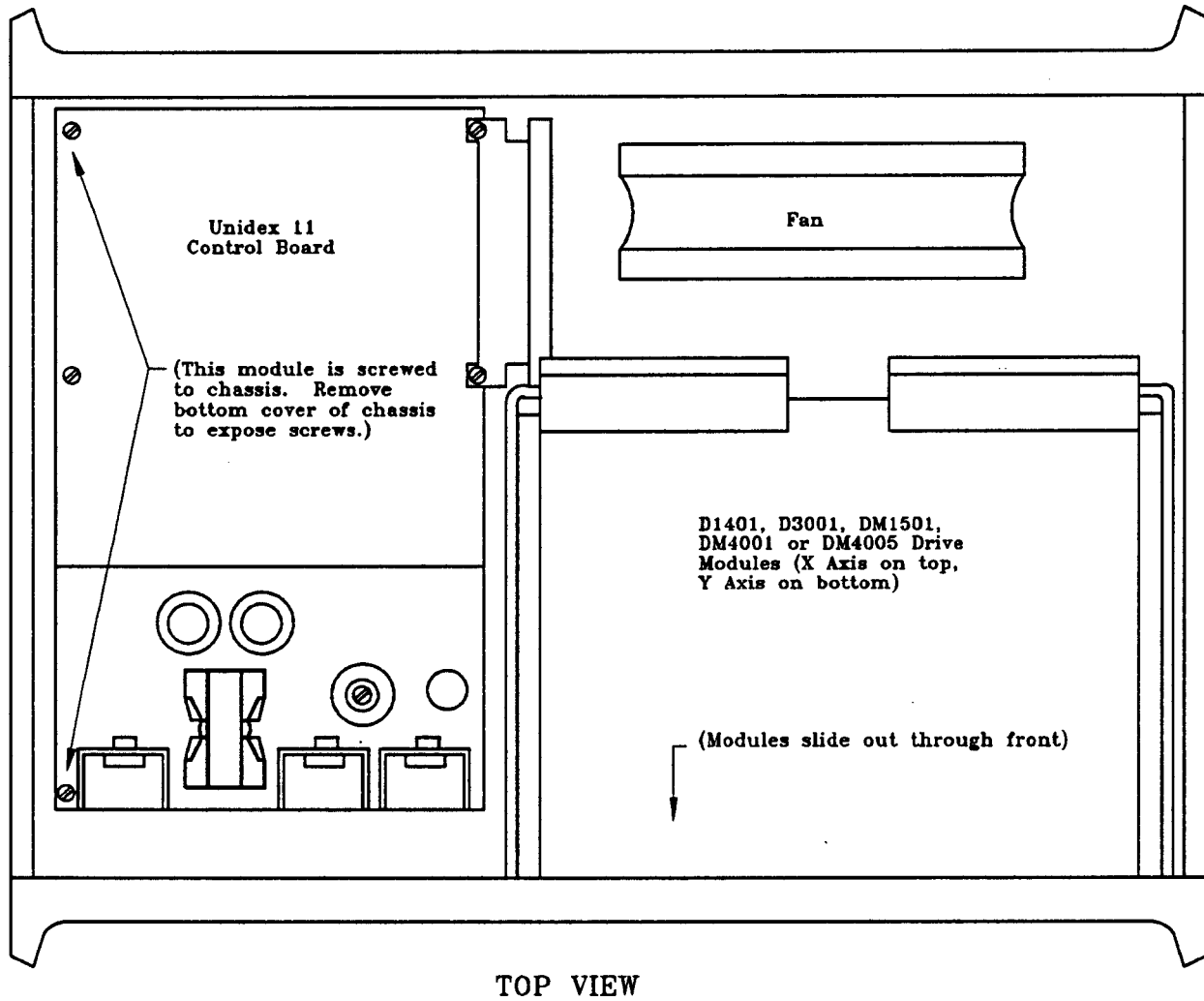

Figure 3-6: Outline of U11M Chassis with Top Cover Removed

CHAPTER 4: STEPPING/DC SERVO DRIVE MODULES

-CONTROL AND POWER BOARD SPECIFICATIONS-

Specifications for the stepping motor drive modules, DC servo drive modules, power supply module, and control module are described in this section.

Information provided for each module described in the following section is limited to the description of the various operational alterations that may be performed on a given module. An example of an alteration may be the re-selection of the "homing" direction from CCW motor rotation to CW motor rotation.

A convention that is maintained throughout the manual involves CW and CCW rotation. All CCW and CW rotational references are assumed "looking into" the motor mounting flange.

SECTION 4-1 D3001/D1401 STEPPING DRIVES

A. CIRCUIT DESCRIPTION

The D3001 and D1401 are designed to accurately control a standard 6 wire unipolar stepping motor. Either unit is jumper selectable for full step (200 steps/rev) or half step (400 steps/rev) resolution. Since these units are RL (resistance, inductance) drives, the phase resistance of the mating stepping motor is important. The D3001 is capable of .5 amps at 30V. The phase resistance of its associated stepping motor must be approximately 30 ohms. The D1401 is capable of 1

amp at 14 V. The phase resistance of its associated stepping motor must be approximately 5 ohms. If stepping motors of less resistance are to be used, certain current limiting resistors on the D3001/D1401 must be changed in value. Please consult the factory if this is required.

A feature unique to the D3001/D1401 Stepping drives is the totally integral power supply circuit. Stepping motor voltages as well as all logic control voltages (+5 and ± 12 VDC) are all generated on board. The only incoming power connection necessary is a factory set 115VAC, 50/60 Hz (nominal) or a 230VAC, 50/60 Hz line connection. Therefore, the DC bus power supply subsystem of the U11S, U11R and U11H chassis (transformer T1 and/or T2 with capacitors C1, C2, C3 and C4, see figures 3-4 and 3-5) is not required when using the D3001/D1401 drive module.

An outline of the D3001/D1401 drive module is shown in figure 4-1. The D3001/D1401 can be used in any Unidex 11 chassis (U11S, U11R, U11H and U11M).

B. "HOME" REFERENCE DEFINITION AND OPTIONS

All Unidex 11 controllers are capable of generating a cold start reference position, which is the home position. The basic home cycle involves the following series of events:

When the "Go Home" command is issued, the motor will turn CCW (standard) or CW (optional) until a "home limit switch" (see section 2-2) activation occurs.

NOTE: The CCW and CW rotational references are viewed as looking into the motor mounting flange.

Upon "home limit switch" activation, the motor will then reverse and rotate in the opposite direction until the switch deactivates. If no "marker" pulse option exists, the motor will stop immediately. If a "marker" pulse option does exist (see section 4-1C), the motor will con-

tinue to rotate until the "marker" pulse is present. At this time, motion ceases.

The speed at which the home cycle occurs is factory set at 120 RPM for the D3001 and at 60 RPM for the D1401. If a different speed is required, see section 4-1J for appropriate personality module changes.

For most rotary motion stages, the "home limit switch" referenced above is an independent switch incorporated specifically for the "home" cycle. For linear motion stages, the "home limit switch" could be an independent switch as well. However, in most cases, the "CCW or CW limit switches" perform double duty, and act as the "home limit switch". Note that the process of putting the "home limit switch" input in parallel with the "CCW" or "CW limit switch" input is standardly done at the motor/stage, external to the Unidex 11 (reference chapter 5 and figure 5-3).

If it is not possible to use the "home limit" input at J13, J14, J19, or J20 (see section 2-2 A & B), such as when Opto 22 coupled limits are being used (see section 2-5), the "CCW or CW limit" input may be paralleled to the "home limit" input by reconfiguring jumpers 16 through 19 on the D3001/D1401 PC board. Note that this scheme is possible only with linear stages and not with rotary states. The jumper definition follows:

HOME LIMIT SOURCE:

(Standard) From Home Limit Input: Jumper 17-19, Remove 16-19,18-19

(Optional) From CCW Limit Input: Jumper 16-19, Remove 17-19,18-19

(Optional) From CW Limit Input: Jumper 18-19, Remove 16-19,17-19

See figure 4-1 for jumper locations.

When the home command is issued, the standard direction of motor rotation is CCW. If CW rotation is required, jumpers 23-24-25 on the D3001/D1401 board must be reconfigured. The jumper definition follows:

(Standard) CCW Home - Jumper 23-24, Remove 24-25
 (Optional) CW Home - Jumper 24-25, Remove 23-24

See figure 4-1 for jumper locations.

C. OUTLINE OF MARKER BUFFER CIRCUIT:

Shown below is a circuit diagram of the differential input marker circuit.

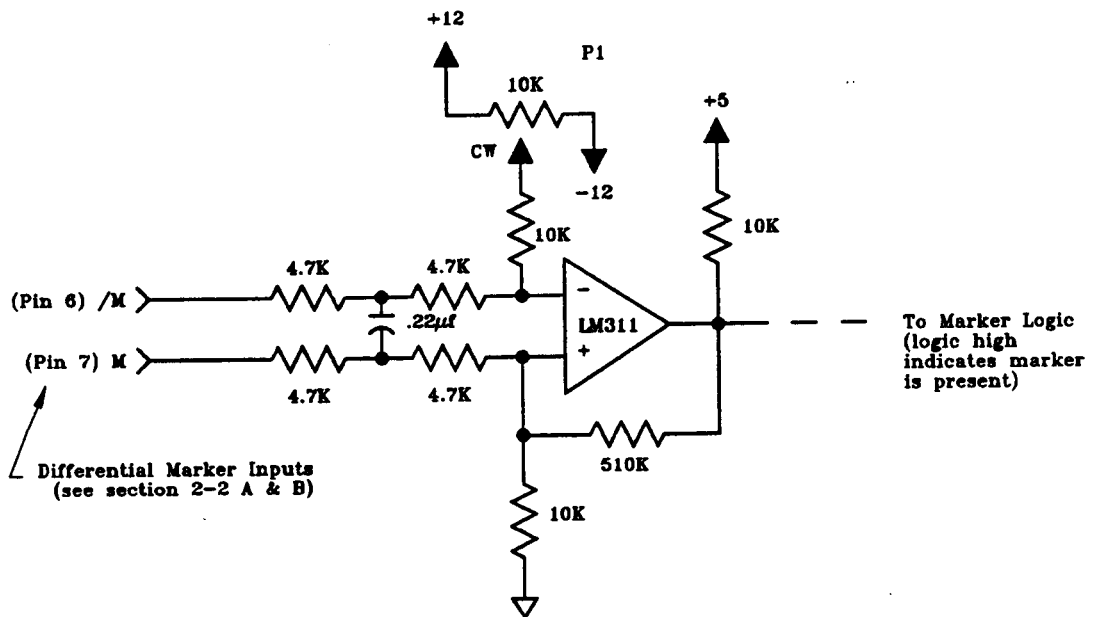

Potentiometer P1 (see figure 4-1) in the circuit diagram above allows the threshold of the marker input signal to be adjusted. The threshold level is increased by turning P1 CW. To activate the marker logic, the voltage signal at "M" must rise slightly higher than the voltage signal at "/M", plus the threshold setting at P1. In other words:

$$M > /M + P1 \text{ (threshold)}$$

For a TTL marker connection, the signal common of the TTL circuit should be tied to signal common with the marker tied to "M". P1 should be adjusted to approximately +1VDC at the P1 wiper.

NOTE: P1 will be factory set so that proper "home cycle" operation will occur when no marker pulse is present or when interfacing to an Aerotech stage/motor with a "home marker" (HM) option. This setting is approximately -1VDC at P1 wiper.

D. LIMIT SWITCH POLARITY SELECTION

As a standard, Unidex 11 controllers are configured to interface to normally open (active low) limit switches (CCW, CW and Home). If use of normally closed (active high) limit switches is required, jumpers 1 through 6 and 13 through 15 on the D3001/D1401 board must be reconfigured. The jumper definitions follow:

- (Standard) CCW Limit, Normally Open - Jumper 1-2, Remove 2-3
- (Optional) CCW Limit, Normally Closed - Jumper 2-3, Remove 1-2
- (Standard) CW Limit, Normally Open - Jumper 5-6, Remove 4-5
- (Optional) CW Limit, Normally Closed - Jumper 4-5, Remove 5-6
- (Standard) Home Limit, Normally Open - Jumper 13-14, Remove 14-15
- (Optional) Home Limit, Normally Closed - Jumper 14-15, Remove 13-14

See figure 4-1 for jumper locations.

E. +/- DIRECTION DEFINITION AND OPTIONS

When a "+" direction is programmed into a Unidex 11, the motor will rotate in the CW direction.

NOTE: CW rotation is viewed looking into the motor mounting flange.

When a "-" direction is programmed, the motor will rotate in the CCW direction. If the opposite convention is required, jumpers 20-21-22 may be reconfigured. The jumper definition follows:

(Standard) "+" = CW, "-" = CCW - Jumper 21-22, Remove 20-21

(Optional) "-" = CW, "+" = CCW - Jumper 20-21, Remove 21-22

See figure 4-1 for jumper locations.

F. AUXILIARY CONTROL OPTIONS FOR U11M CHASSIS

On the U11M chassis only, it is possible to select between two different manual control command sets (see section 2-3C). Either "external clock/direction" commands or "slew/step/direction" commands may be chosen. The jumper definition follows:

(Standard) External Clock/Direction Mode - Jumper 9-11, 10-12, Remove 9-10, 11-12

(Optional) Slew/Step/ Direction Mode - Jumper 9-10, 11-12, Remove 9-11, 10-12

See figure 4-1 for jumper locations.

G. SELECTING STEPPING MOTOR RESOLUTION

The D3001/D1401 can be operated in the full step mode (200 steps/rev) or the half step mode (400 steps/rev). In the Unidex 11 chassis, the resolution will be set according to the suffix in the part number, (for example, D3001-4 (400 steps/rev), D1401-2 (200 steps/rev)). If required, the resolution may be changed by reconfiguring jumpers 29-30-31. The jumper definition follows:

Half Step - Jumper 30-31, Remove 29-30

Full Step - Jumper 29-30, Remove 30-31

H. PERSONALITY MODULE (RCN1)

The personality module is a 16-pin DIP wafer consisting of 2 resistors and a capacitor. This module contains all of the parameters used to match a given stepping motor with a given resolution for the D3001 or D1401. A representation of a personality module is shown below.

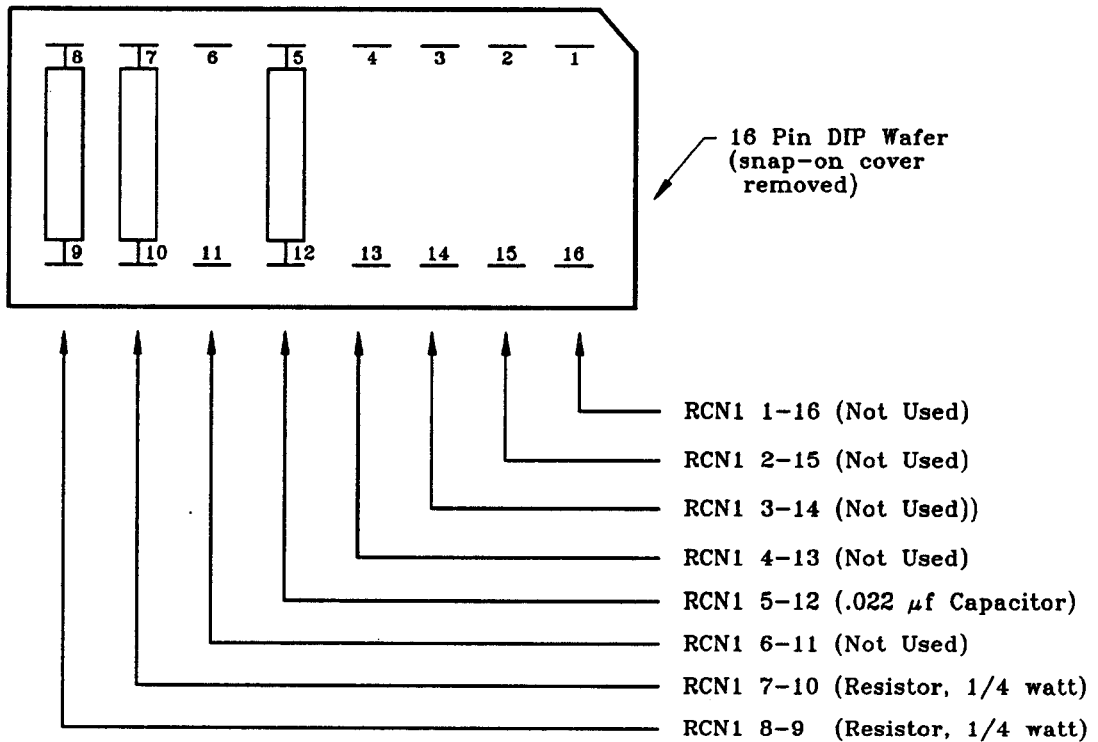

The parameter settings of RCN1 are explained in the following subsections.

I. RCN1 7-10, /SLEW CLOCK OSCILLATOR ADJUSTMENT

(Applicable only to U11M Chassis with optional auxiliary controls)

The internal slew clock oscillator frequency can be set by manipulating the value of RCN1 7-10. With programming jumper 7 to 8 inserted (this jumper should always be inserted), the value of RCN1 7-10 can be determined for a given slew clock frequency as follows:

$$\text{Slew Clock Frequency (Hz)} \sim \frac{1}{2(\text{RCN17-10}) (2.2 \times 10^{-9})}$$

Where RCN17-10 is in ohms

J. RCN1 8-9, HOME CLOCK OSCILLATOR ADJUSTMENTS

The adjustment for the oscillator which sends the stepping motor into a limit involves RCN1 8-9. This value can be determined as follows:

$$\text{Home Clock Frequency (Hz)} \sim \frac{1}{1.5(.022 \times 10^{-6}) (\text{RCN18-9})}$$

Where RCN18-9 is in ohms

NOTE: RCN1 5-12 is factory selected for the D3001. This component should *never* be changed by the user.

The D3001 or D1401 is shipped with a standard personality module, which is defined by the resolution (i.e., 200 or 400 steps per revolution). If the D3001/D1401 is being used with a standard Aerotech stepping motor, the user need only define the desired resolution in which the motor is to operate. If the D3001/D1401 is not being used with a standard Aerotech motor, the user must define the type of stepping motor being used, with its rated phase current and rated phase resistance, as well as the resolution in which it is to operate.

A list of personality modules used with standard Aerotech stepping motors is listed after the following illustration. The label on the personality module defines the resolution (of the internal oscillators) and motor phase current parameters for that unit. If not using Aerotech motors, a custom personality module can be ordered using the part numbering format shown below. Given the rated current and resistance for a particular motor, Aerotech will accordingly modify the D3001/D1401 and set the slew and the home oscillators. Although it is not generally recommended, the user also has the option of changing the parameters of the personality modules himself, by using the equations listed in sections I and J. Note that the current levels are set by a combination of motor phase resistance and power resistors on the D3001/D1401 PC board. These resistors should only be changed by the factory.

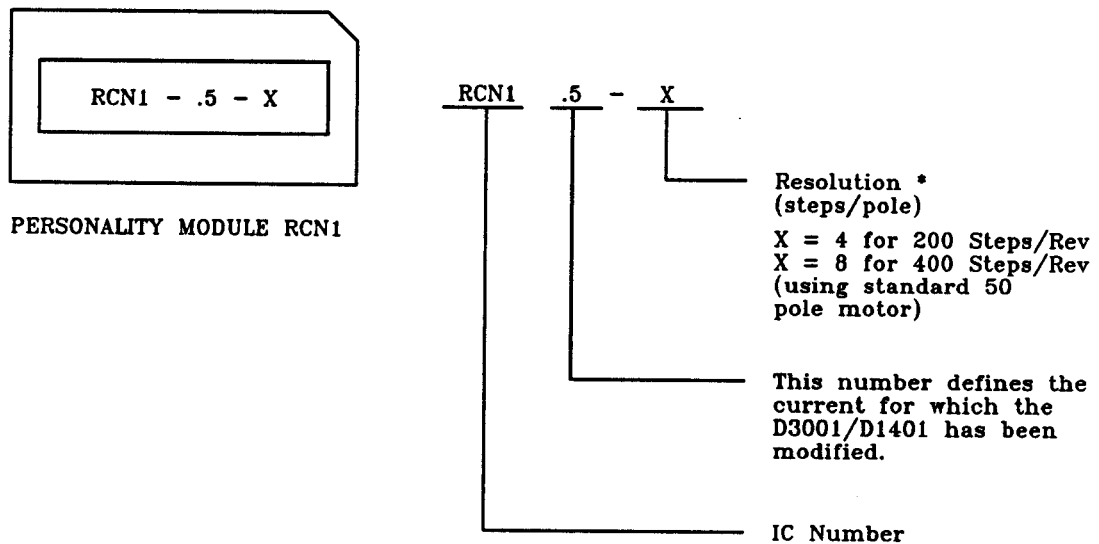

Recommended standard RCN1 modules for the D3001/D1401 are:

Drive	Resolution (Steps/Rev)	Motor	Phase Current (Amps)	Torque (Oz-In)	Recommended Personality Module (RCN1)
D3001	200	45SM	.5	38	RCN1 - .5 - 4
D3001	400	45SM	.5	38	RCN1 - .5 - 8
D1401	200	Phytron	1	13	RCN1 - 1 - 4
D1401	400	Phytron	1	13	RCN1 - 1 - 8

Contact Aerotech for Customized Personality Modules.

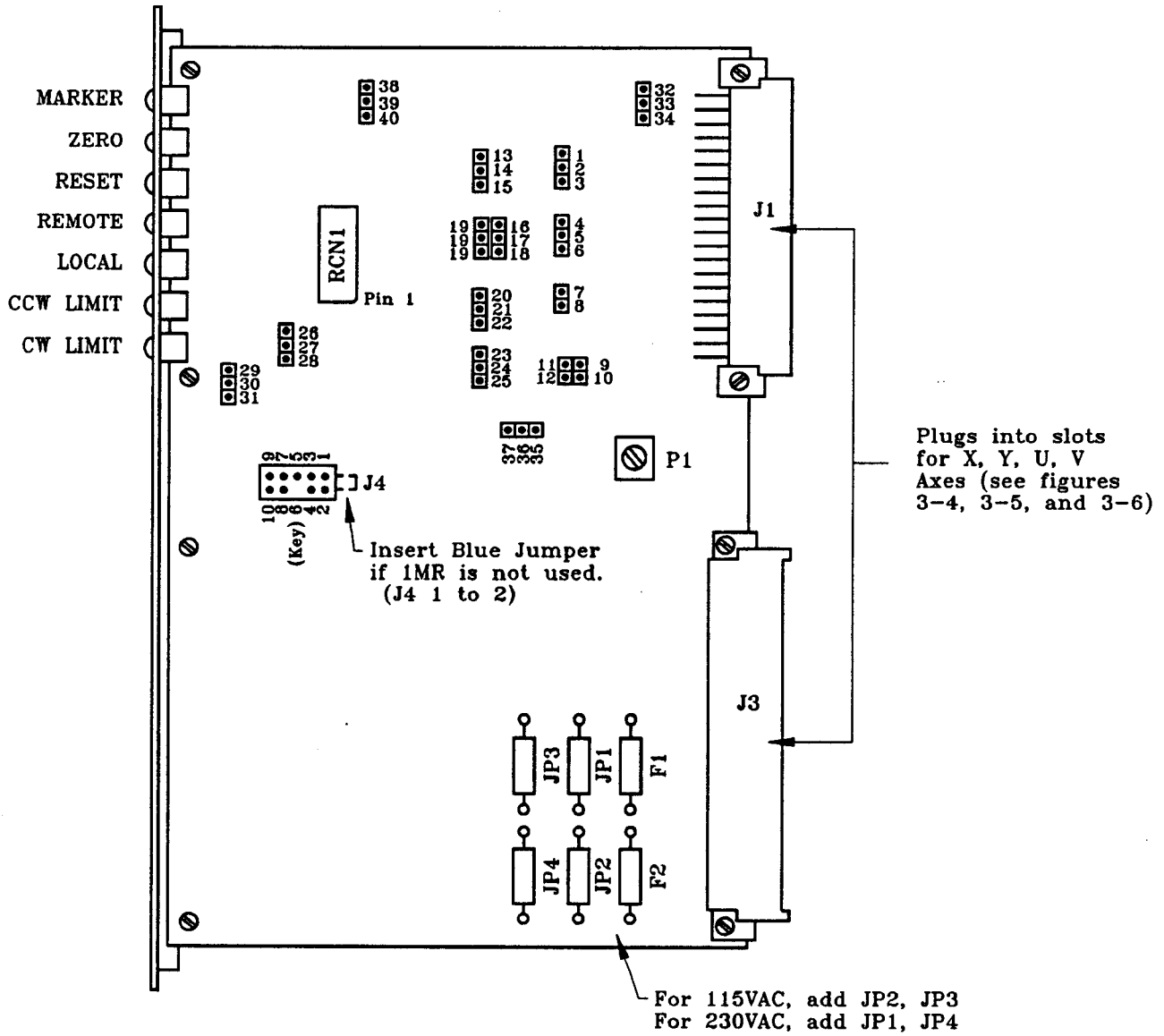

Figure 4-1: Assembly Outline of D3001/D1401

SECTION 4-2 DM4001, 4005 & 1501 STEPPING DRIVES

A. CIRCUIT DESCRIPTION

The DM4005, 4001, 1501 are designed to accurately control a standard unipolar stepping motor by utilizing a unique sin/cos translator control. This control is capable of dividing a full- step size into 1000 evenly spaced micro steps. For a 50 pole (standard) stepping motor, this subdivision of a full step provides electrical resolutions of up to 50,000 steps per revolution. This sin/cos translator control, as mentioned in the introduction, can be easily altered to provide other step sizes. By simply programming two IC chips, a host of other incremental step sizes can be chosen, ranging from 200 steps/rev (full step) up to 50,000 steps/rev in 200 step intervals. In other words, there are 250 choices of stepping resolutions.

Another feature unique to the DM4005, 4001, and 1501 is the totally integral power supply circuit. Stepping motor voltages as well as all logic control voltages (+5 and ± 12 VDC) are all generated on the board. The only incoming power connection necessary is a standard 115VAC 50/60 Hz (nominal) or a 230VAC 50/60 Hz line connection. Thus, the DC bus power supply subsystem of the U11S, U11R and U11H chassis (transformer T1 and/or T2 with capacitors C1, C2, C3 and C4, see figures 3-4 and 3-5) is not required. The power supply board module (described in this chapter) is *not* required when using this drive module.

An outline of the DM1501, DM4001 and DM4005 drive modules is shown in figure 4-2.

This module can be used in an Unidex 11 chassis (U11S, U11R, U11H and U11M).

B. "HOME" REFERENCE DEFINITION AND OPTIONS

All Unidex 11 controllers are capable of generating a cold start reference position, which is the "home" position. The basic home cycle involves the following series of events. When the "go home" command has been issued, the motor will turn CCW (standard) or CW (optional) until a "home limit switch" activation occurs (see section 2-2).

NOTE: The CCW and CW rotational references are viewed looking into the motor mounting flange.

Upon "home limit switch" activation, the motor will reverse and rotate in the opposite direction until the switch deactivates. If no "marker" pulse option exists, the motor will stop immediately. If a "marker" pulse option does exist (see section 4-2C), the motor will continue to rotate until the "marker" pulse is present. At this time, motion ceases.

The speed at which the home cycle occurs is factory set at 120RPM for the DM4005/4001 and 60RPM for the DM1501. If a different speed is required, see section 4-2J for appropriate personality module changes.

For most rotary motion stages, the "home limit switch" referenced above is an independent switch incorporated specifically for the "home" cycle. For linear motion stages, the "home limit switch" could be an independent switch as well. However, in most cases, the CCW or CW limit switches perform "double duty" and act as the "home limit switch". Note that the process of putting the "home limit switch" input in parallel with the CCW or CW limit switch input is standardly done at the motor/stage, external to the Unidex 11 (refer to chapter 5 and figure 5-3).

If it is not possible to use the "home limit" input at J13, 14, 19 or 20 (see section 2-2 A & B), such as when Opto 22 coupled limits are

being used (see section 2-5), the "CCW" or "CW limit" input may be paralleled to the "home limit" input by reconfiguring jumpers 16 through 19 on the DM4005/DM4001/DM1501 PC board. Note that this scheme is possible only with linear stages and not with rotary stages. The jumper definition follows:

HOME LIMIT SOURCE:

(Standard) From Home Limit Input: Jumper 17-19, Remove 16-19, 18-19.

(Optional) From CCW Limit Input: Jumper 16-19, Remove 17-19, 18-19.

(Optional) From CW Limit Input: Jumper 18-19, Remove 16-19, 17-19

See figure 4-2 for jumper locations.

When the home command is issued, the standard direction of motor rotation is CCW. If CW rotation is required, jumpers 23-24-25 on the DM4005/4001/1501 board must be reconfigured. The jumper definition follows:

(Standard) CCW Home - Jumper 23-24, Remove 24-25

(Optional) CW Home - Jumper 24-25, Remove 23-24

See figure 4-2 for jumper locations.

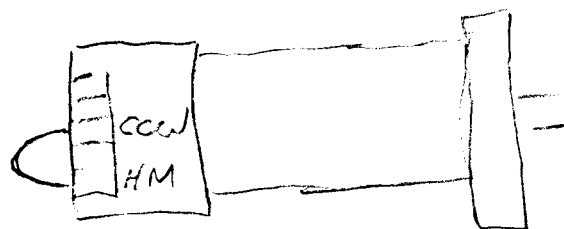

Jumper is located here
on back of the motor

C. OUTLINE OF MARKER BUFFER CIRCUIT

Shown below is a circuit diagram of the differential input marker circuit.

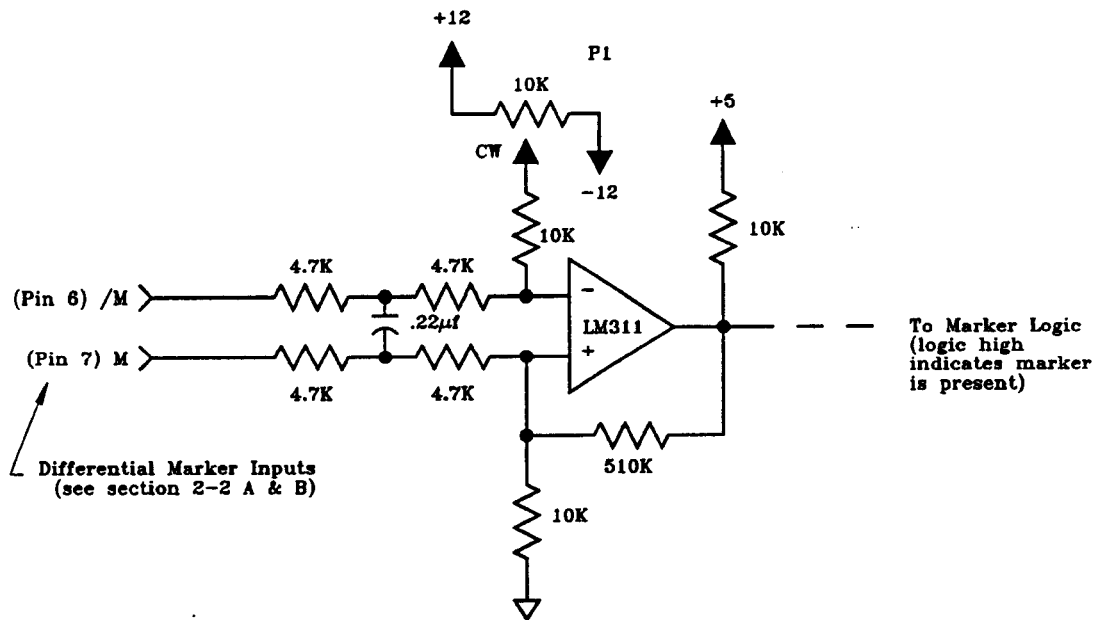

Potentiometer P1 (see figure 4-2) in the circuit above, allows the threshold of the marker input signal to be adjusted. The threshold level is increased by turning P1 CW. To activate the marker logic, the voltage signal at "M" must rise slightly higher than the voltage signal at "/M", plus the threshold setting at P1. In other words:

$$M > /M + P1 \text{ (threshold)}$$

For a TTL marker connection, the signal common of the TTL circuit should be tied to signal common with the marker tied to "M". P1 should be adjusted to +1VDC at the P1 wiper.

NOTE: P1 will be factory set such that proper "home cycle" operation will occur when no marker pulse is present or when interfacing to an Aerotech stage/motor with a "home marker" (HM) option. This setting is approximately -1VDC at the P1 wiper.

D. LIMIT SWITCH POLARITY SELECTION

As a standard, Unidex 11 Controllers are configured to interface to normally open (active low) limit switches (CCW, CW and Home). If use of normally closed (active high) limit switches is required, jumpers 1 through 6 and 13 through 15 on the DM4005/4001/1501 board must be reconfigured. The jumper definitions follow:

(Standard) CCW Limit, Normally Open - Jumper 1-2, Remove 2-3

(Optional) CCW Limit, Normally Closed - Jumper 2-3, Remove 1-2

(Standard) CW Limit, Normally Open - Jumper 5-6, Remove 4-5

(Optional) CW Limit, Normally Closed - Jumper 4-5, Remove 5-6

(Standard) Home Limit, Normally Open - Jumper 13-14, Remove 14-15

(Optional) Home Limit, Normally Closed - Jumper 14-15, Remove 13-14

See figure 4-2 for jumper locations.

E. +/- DIRECTION DEFINITION AND OPTIONS

When a "+" direction is programmed into a Unidex 11, the motor will rotate in the CW direction.

NOTE: Again, CW rotation is viewed as looking into the motor mounting flange.

When a "-" direction is programmed, the motor will rotate in the CCW direction. If the opposite convention is required, jumpers 20-21-22 may be reconfigured. The jumper definition follows:

(Standard) "+" = CW, "-" = CCW - Jumper 21-22, Remove 20-21

(Optional) "-" = CW, "+" = CCW - Jumper 20-21, Remove 21-22

See figure 4-2 for jumper locations.

F. AUXILIARY CONTROL OPTIONS FOR U11M CHASSIS

On the U11M chassis only, it is possible to select between two different manual control command sets (see section 2-3C). Either "external clock/direction" commands or "slew/step/direction" commands may be chosen. The jumper definition follows:

Standard- External clock/direction mode - Jumper 9-11, 10-12, Remove 9-10,11-12

Optional - Slew/step/direction mode - Jumper 9-10,11-12, Remove 9-11,10-12

See figure 4-2 for jumper locations.

G. SELECTING STEPPING MOTOR RESOLUTION

The DM4005/4001/1501 series can be programmed to drive a stepping motor at 250 different stepping resolutions. As was described in part A (circuit description), a stepping resolution range can be selected between 200 steps/rev and 50,000 steps/rev inclusive, in increments of 200 steps (i.e., 200, 400, 600,....49600, 49800 and 50000 steps/rev).

The changing of resolution on the DM4005/4001/1501 involves the programming of two IC chips, M15 and M17. This programming cannot be done in the field. However, M15 and M17 can be changed very easily in the field since both ICs are mounted on IC sockets.

The part numbering system for M15 and M17 is shown below. These part numbers must be used when ordering different control resolutions.

For IC M15:

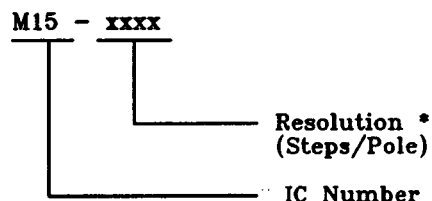
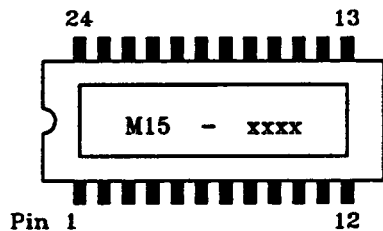

For IC M17:

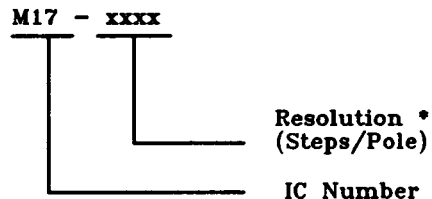
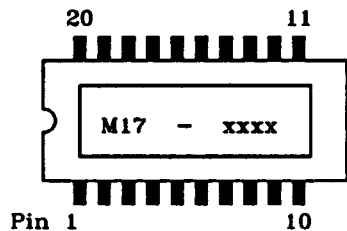

* NOTE: This number defines the resolution (in steps/pole)

For example:

POLE RESOLUTIONS
(STEPS/POLE)

1000	—————>	50000 Steps/Rev	For standard 1.8° /pole motors
720	—————>	36000 Steps/Rev	
80	—————>	4000 Steps/Rev	
18	—————>	800 Steps/Rev	

As was mentioned in the introduction of this manual, the step/rev numbers listed above apply to a 50-pole 1.8 degree per step stepping motor. When determining step/rev for other multiple pole motors, multiply the given steps/pole resolution by the number of poles for the given stepping motor. The resulting number will then be the step/rev resolution for that motor.

When changing resolutions, it is common to change personality module RCN1 also, so that home speed and slew speed (if applicable) vary according to resolution.

H. PERSONALITY MODULE (RCN1)

The personality module is a 16-pin DIP wafer consisting of 5 resistors and 2 capacitors. This module contains all of the parameters used to match a given stepping motor with a given resolution for the DM4005/4001/1501. A representation of a personality module is shown below (see also figure 4-2).

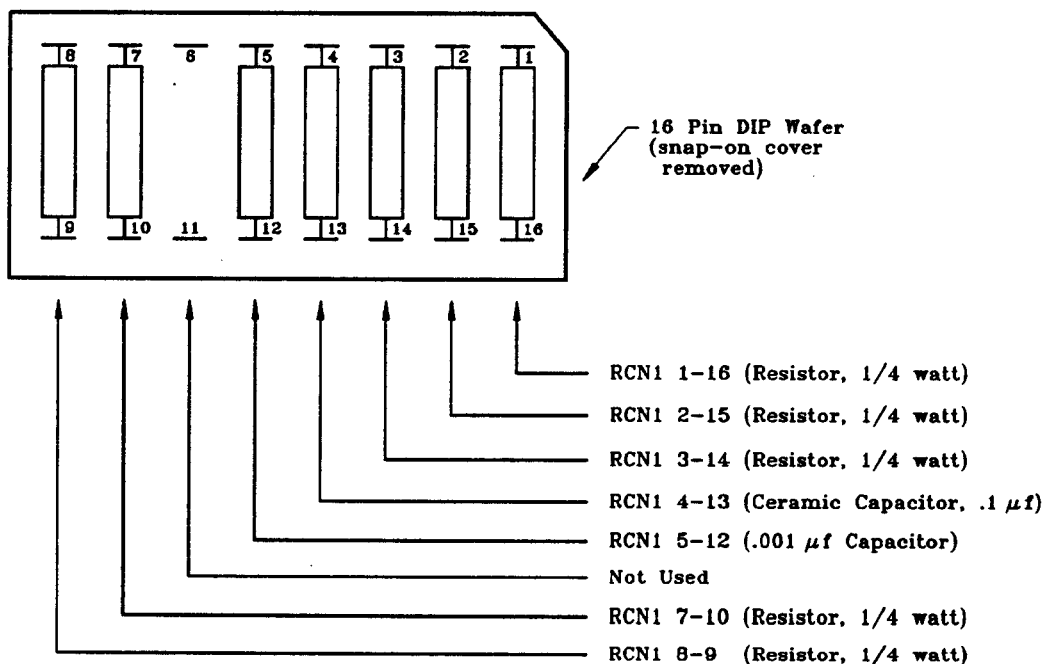

The parameter settings of RCN1 are explained in the following sub-sections.

I. RCN1 7-10, /SLEW CLK OSCILLATOR ADJUSTMENT

(Applicable only to U11M Chassis with Optional Aux Controls)

The internal slew clock oscillator frequency can be set by manipulating the value of RCN1 7-10. With programming jumper 7 to 8 inserted (this jumper should always be inserted), the value of RCN1 7-10 can be determined for a given slew clock frequency as follows:

$$\text{Slew Clock Frequency (Hz)} \sim \frac{1}{2(\text{RCN1 } 7-10)(470 \times 10^{-12})}$$

Where RCN17-10 is in ohms

J. RCN1 8-9, HOME CLOCK OSCILLATOR ADJUSTMENT

The adjustment for the oscillator which sends the stepping motor into a limit involves RCN1 8-9. This value can be determined as follows:

$$\text{Home Clock Frequency (Hz)} \sim \frac{1}{1.5(.001 \times 10^{-6})(\text{RCN1 } 8-9)}$$

Where RCN1 8-9 is in ohms

K. RCN1 3-14 AND RCN1 2-15, LO/HI CURRENT LEVELS

The low current level (standby current when motor is at rest) is set by RCN1 2-15. This value of current can be calculated as follows:

$$\text{Standby Current Level (amps)} = N \left(\frac{1 \times 10^4}{\text{RCN1 2-15}} \right)$$

Where RCN1 2-15 is in ohms

N = 1 for DM4001, DM1501

N = 5 for DM4005

The high current level (running current) involves the selection of RCN1 3-14 and RCN1 2-15 (determined above). The value can be calculated as follows:

$$\text{Running Current Level (amps)} = N \left(\frac{1 \times 10^4}{\text{RCN1 2-15}} + \frac{1 \times 10^4}{\text{RCN1 3-14}} \right)$$

Where RCN1 2-15 and RCN1 3-14 are in ohms

N = 1 for DM4001, DM1501

N = 5 for DM4005

NOTE: RCN1 1-16, RCN1 4-13, RCN1 6-11 and RCN1 5-12 are factory selected for the DM4000/1501 Series. These components should *never* be changed by the user.

The DM4005/4001/1501 are shipped with standard personality modules, which are defined by the resolution and rated phase current of the stepping motor being used. If the DM4000/1501 Series is being used with a standard Aerotech stepping motor, the user need only define the desired resolution in which the motor is to operate. If the DM4000/1501 Series is not being used with a standard Aerotech motor, the user must define the type of stepping motor being used, with its rated phase current, as well as the DM4000/1501 Series resolution in which it is to operate.

A list of personality modules used with standard Aerotech stepping motors is listed after the next illustration. The label on the personality modules defines the resolution (of the internal oscillators) and motor phase current parameters for that module. If the user is not using Aerotech motors, a custom personality module can be ordered using the part numbering format shown below. Given the rated current and resolution information for a particular motor, Aerotech will set the slew oscillators, the home oscillator and the Run/Standby phase current levels. Although it is not generally recommended, the user also has the option of changing the parameters of the personality module himself by using the equations listed in parts I, J and K.

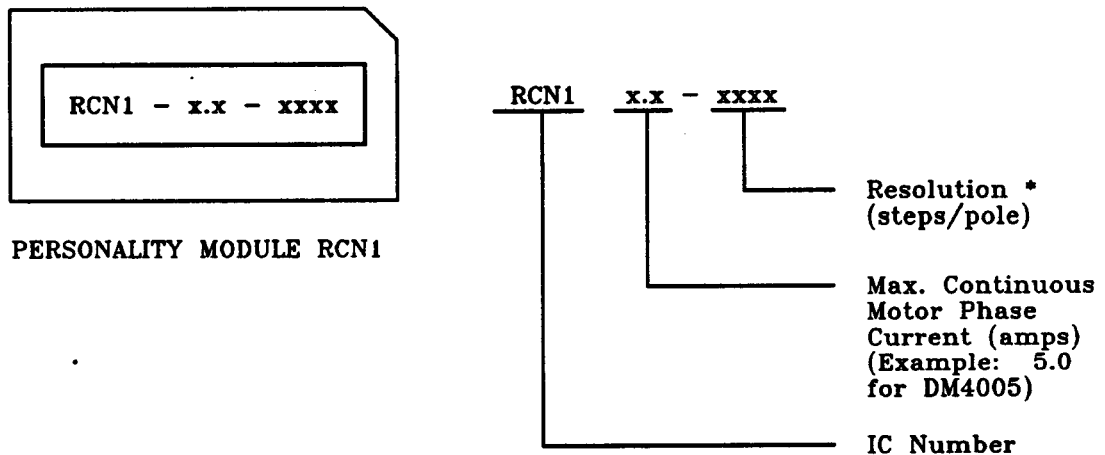

* This number defines the resolution (in steps per pole), for which the slew and home oscillator, as well as the current levels of the personality module, are "tailored" to operate.

Recommended standard RCN1 modules for the DM4000/1501 Series are:

Aerotech Translator	Motor	Phase Current (amps)	Torque (oz-in)	Recommended Personality Module (RCN1)
DM4001	50SM	1	38	RCN1 1.0 - xxxx
DM4005	101SM	4.6	90	RCN1 5.0 - xxxx
DM1501	Phytron ZSS 33-200- 1.2	1	13	RCN1 1.0 - xxxx

Contact Aerotech for Customized Personality Modules

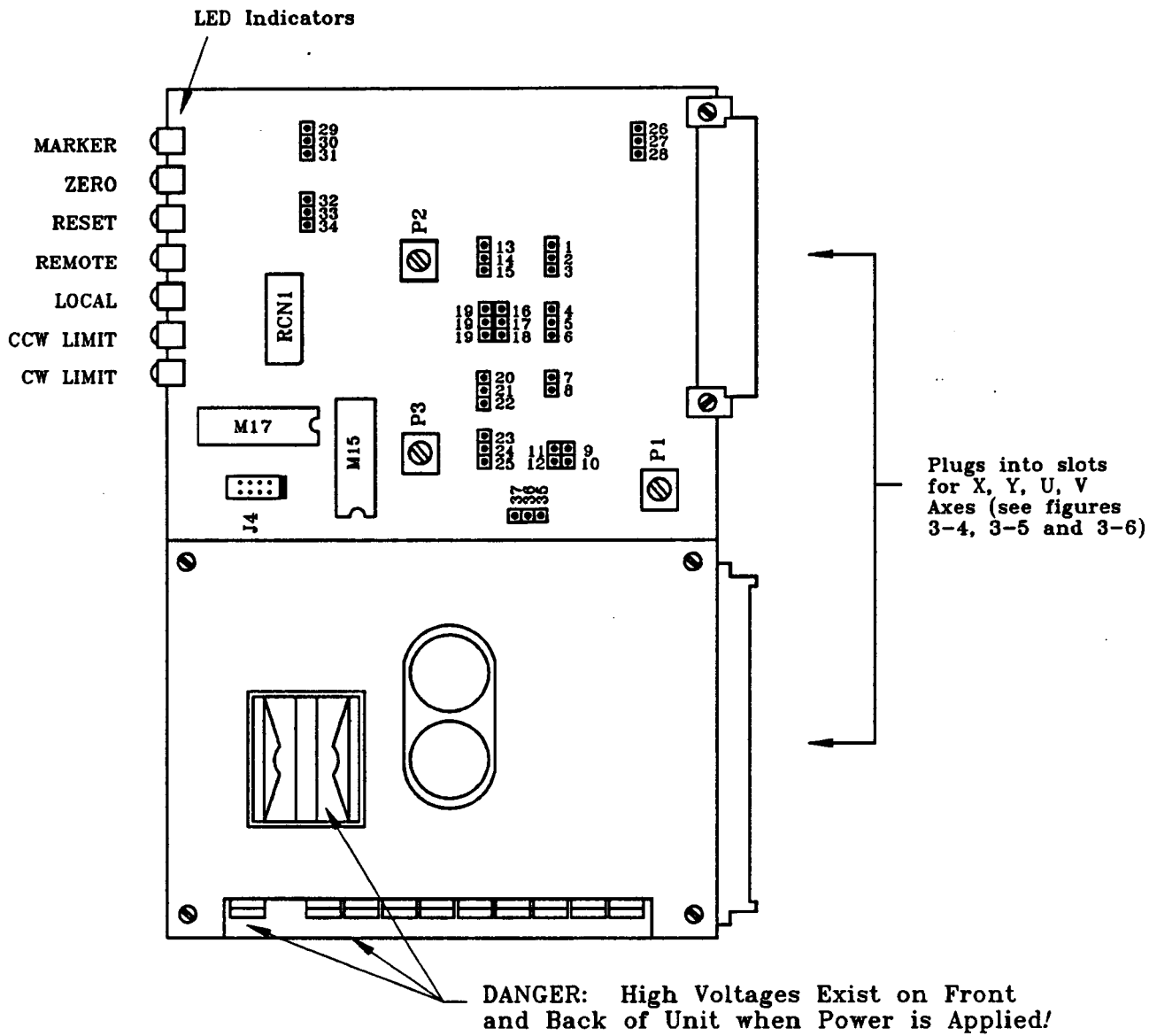

Figure 4-2: Outline of DM4005/4001/1501 Stepping Drive Module

SECTION 4-3 DM6006 STEPPING DRIVE MODULE

A. CIRCUIT DESCRIPTION

The DM6006 is designed to accurately control a standard bipolar stepping motor by utilizing a unique sin/cos translator control. This control is capable of dividing a full-step size into 1000, evenly spaced micro steps. For a 50 pole (standard) stepping motor, this subdivision of a full step provides electrical resolutions of up to 50,000 steps per revolution. This sin/cos translator control, as mentioned in the introduction, can be easily altered to provide other step sizes. By simply programming two IC chips, a host of other incremental step sizes can be chosen, ranging from 200 steps/rev (full step) up to 50,000 steps/rev in 200 step intervals. In other words, there are 250 choices of stepping resolutions.

Another feature unique to the DM6006 is its totally integral power supply circuit (also patent pending). Stepping motor voltages as well as all logic control voltages (+5 and ± 12 VDC) are all generated on the DM6006. The only incoming power connection necessary is a standard 115VAC 50/60 Hz (nominal) or a 230VAC 50/60 Hz line connection.

Therefore, in lieu of the module's integrated power supply circuit, the DC bus power supply subsystem of the U11S, U11R and U11H chassis (transformer T1 and/or T2 with capacitors C1, C2, C3 and C4, see figures 3-4 and 3-5) are not required. The power supply board module (described in this chapter) is *not* required when using this drive module.

An outline of the DM6006 drive modules is shown in figure 4-3.

This module can be used in Unidex 11 chassis' U11R, U11S and U11H. (It can also be used in a U11M chassis if only one axis (X axis) is required.)

B. "HOME" REFERENCE DEFINITION & OPTIONS

All Unidex 11 controllers are capable of generating a cold start reference position, which is the "home" position. The basic home cycle involves the following series of events. When the "go home" command has been issued, the motor will turn CCW (standard) or CW (optional) until a "home limit switch" activation occurs (see section 2-2).

NOTE: The CCW and CW rotational references are viewed looking into the motor mounting flange.

Upon "home limit switch" activation, the motor will reverse and rotate in the opposite direction until the switch deactivates. If no "marker" pulse option exists, the motor will stop immediately. If a "marker" pulse option does exist (see section 4-3C), the motor will continue to rotate until the "marker" pulse is present. At this time, motion ceases.

The speed at which the home cycle occurs is factory set at 120RPM. If a different speed is required, see section 4-3J for appropriate personality module changes.

For most rotary motion stages, the "home limit switch" referenced above is an independent switch incorporated specifically for the "home" cycle. For linear motion stages, the "home limit switch" could be an independent switch as well. However, in most cases, the CCW or CW limit switches perform "double duty" and act as the "home limit switch". Note that the process of putting the "home limit switch" input in parallel with the CCW or CW limit switch input is standardly done at the motor/stage, external to the Unidex 11 (refer to chapter 5 and figure 5-3).

If it is not possible to use the "home limit" input at J13, 14, 19 or 20 (see section 2-2 A & B), such as when Opto 22 coupled limits are being used (see section 2-5), the "CCW" or "CW limit" input may be paralleled to the "home limit" input by reconfiguring jumpers 16 through 19 on the DM6006 PC board. Note that this scheme is possible only with linear stages and not with rotary stages. The jumper definition follows:

HOME LIMIT SOURCE:

(Standard) From Home Limit Input: Jumper 17-19, Remove 16-19,18-19.

(Optional) From CCW Limit Input: Jumper 16-19, Remove 17-19, 18-19.

(Optional) From CW Limit Input: Jumper 18-19, Remove 16-19, 17-19

See figure 4-3 for jumper locations.

When the home command is issued, the standard direction of motor rotation is CCW. If CW rotation is required, jumpers 23-24-25 on the DM6006 board must be reconfigured. The jumper definition follows:

(Standard) CCW Home - Jumper 23-24, Remove 24-25

(Optional) CW Home - Jumper 24-25, Remove 23-24

See figure 4-3 for jumper locations.

C. OUTLINE OF MARKER BUFFER CIRCUIT:

Shown below is a circuit diagram of the differential input marker circuit:

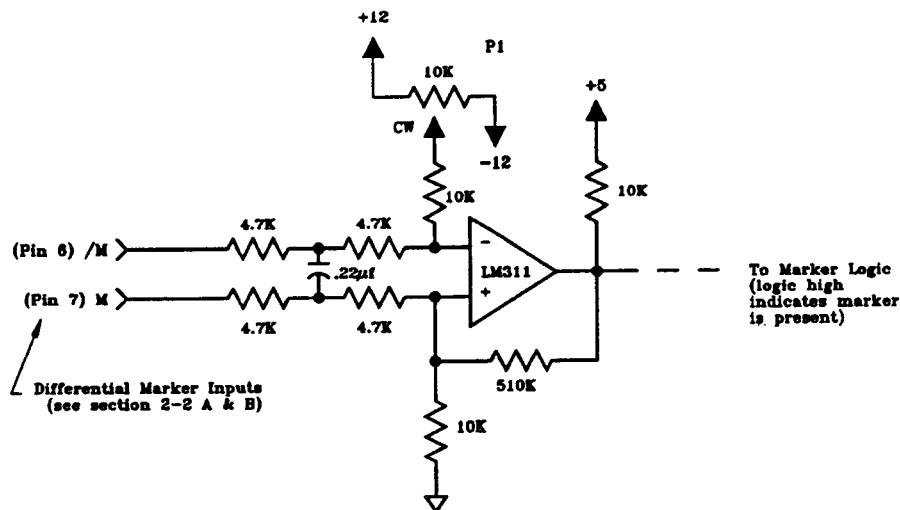

Potentiometer P1 in the circuit diagram above allows the threshold of the marker input signal to be adjusted. The threshold level is increased by turning P1 CW. To activate the marker logic, the voltage signal at "M" must rise slightly higher than the voltage signal at "/M", plus the threshold setting at P1. In other words:

$$M > /M + P1 \text{ (threshold)}$$

For a TTL marker connection, the signal common of the TTL circuit should be tied to signal common with the marker tied to "M". P1 should be adjusted to approximately +1VDC at the P1 wiper.

NOTE: P1 will be factory set so that proper "home cycle" operation will occur when no marker pulse is present, or when interfacing to an Aerotech stage/motor with a "home marker" (HM) option. This setting is approximately -1VDC at the P1 wiper.

D. LIMIT SWITCH POLARITY SELECTION

As a standard, Unidex 11 controllers are configured to interface to normally open (active low) limit switches (CCW, CW, and Home). If use of normally closed (active high) limit switches is required, jumpers 1 through 6 and 13 through 15 on the DM6006 board must be reconfigured. The jumper definitions follow:

(Standard) CCW Limit, Normally Open - Jumper 1-2, Remove 2-3

(Optional) CCW Limit, Normally Closed - Jumper 2-3, Remove 1-2

(Standard) CW Limit, Normally Open - Jumper 5-6, Remove 4-5

(Optional) CW Limit, Normally Closed - Jumper 4-5, Remove 5-6

(Standard) Home Limit, Normally Open - Jumper 13-14, Remove 14-15

(Optional) Home Limit, Normally Closed - Jumper 14-15, Remove 13- 14

See figure 4-3 for jumper locations.

E. +/- DIRECTION DEFINITION & OPTIONS

When a "+" direction is programmed into a Unidex 11, the motor will rotate in the CW direction.

NOTE: Again, CW rotation is viewed as looking into the motor mounting flange.

When a "-" direction is programmed, the motor will rotate in the CCW direction. If the opposite convention is required, jumpers 20-21-22 may be reconfigured. The jumper definition follows:

(Standard) "+" = CW, "-" = CCW - Jumper 21-22, Remove 20-21

(Optional) "-" = CW, "+" = CCW - Jumper 20-21, Remove 21-22

See figure 4-3 for jumper locations.

F. AUXILIARY CONTROL OPTIONS FOR U11M CHASSIS

On the U11M chassis only, it is possible to select between two different manual control command sets (see section 2-3C). Either "external clock/direction" commands or "slew/step/direction" commands may be chosen. The jumper definition follows:

(Standard) External clock/direction mode - Jumper 9-11, 10-12, Remove 9-10,11-12

(Optional) - Slew/step/direction mode - Jumper 9-10,11-12, Remove 9-11,10-12

See figure 4-3 for jumper locations.

G. SELECTING STEPPING MOTOR RESOLUTION

The DM6006 can be programmed to drive a stepping motor at 250 different stepping resolutions. As was described in subsection A of this section (*Circuit Description*), a stepping resolution range can be selected between 200 steps/rev and 50,000 steps/rev inclusive, in increments of 200 steps (i.e., 200, 400, 600,....., 49600, 49800 and 50000 steps/rev).

The changing of resolution on the DM6006 involves the programming of two IC chips, M15 and M17 (see figure 4-3). This programming cannot be done in the field. However, M15 and M17 can be changed very easily in the field since both ICs are mounted on IC sockets.

The part numbering system for M15 and M17 is shown in the following illustration. These part numbers must be used when ordering different control resolutions.

For IC M15:

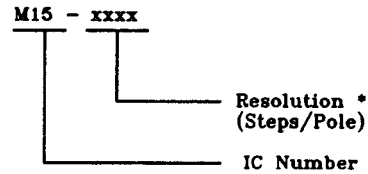
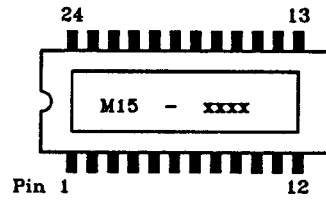

For IC M17:

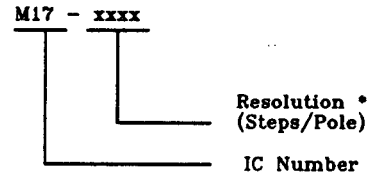
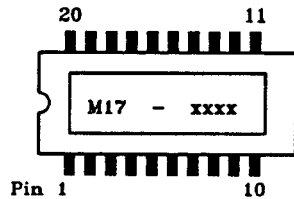

* NOTE: This number defines the resolution (in steps/pole).

For example:

POLE RESOLUTIONS
(STEPS/POLE)

1000	—————>	50000 Steps/Rev	For standard 1.8° /pole motors
720	—————>	36000 Steps/Rev	
80	—————>	4000 Steps/Rev	
16	—————>	800 Steps/Rev	

As was mentioned in the introduction to this section, the step/rev numbers listed above apply to a 50-pole 1.8 degree per full step stepping motor. When determining steps/rev for other multiple pole motors, multiply the given steps/pole resolution by the number of poles for the given stepping motor. The resulting number will then be the step/rev resolution for that motor.

H. PERSONALITY MODULE (RCN2)

The personality module is a 16-pin DIP wafer consisting of 5 resistors and 2 capacitors. This module contains all of the parameters used to match a given stepping motor with a given resolution for the DM6006. A representation of a personality module is shown below:

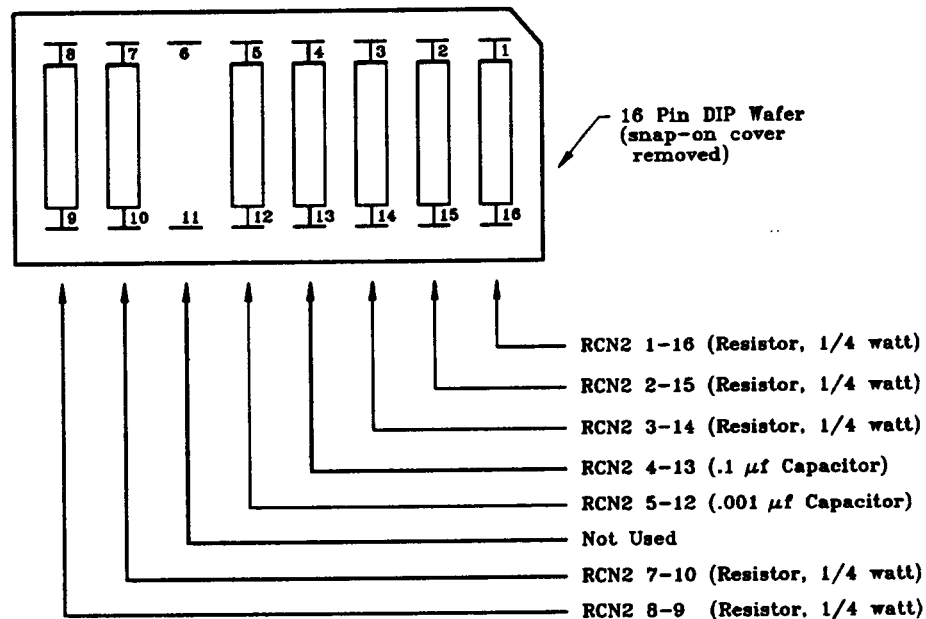

The parameter settings of RCN2 are as follows:

I. RCN2 7-10, /SLEW CLOCK OSCILLATOR ADJUSTMENT

(Applicable to U11M Chassis with Opt. Aux Controls Only)

The internal slew clock oscillator frequency can be set by manipulating the value of RCN2 7-10. With programming jumper 7 to 8 inserted (this jumper should always be inserted) the value of RCN2 7-10 can be determined for a given slew clock frequency as follows:

$$\text{Slew Clock Frequency (Hz)} \sim \frac{1}{2(\text{RCN2 } 7-10) (470 \times 10^{-12})}$$

Where RCN2 7-10 is in ohms

J. RCN2 8-9, HOME CLOCK OSCILLATOR ADJUSTMENT

The adjustment for the oscillator which sends the stepping motor into a limit involves RCN2 8-9. This value can be determined as follows:

$$\text{Home Clock Frequency (Hz)} \sim \frac{1}{1.5(.001 \times 10^{-6}) (\text{RCN2 } 8-9)}$$

Where RCN2 8-9 is in ohms

K. RCN2 3-14 & 2-15, LO/HI CURRENT LVL ADJUSTMENT

The low current level (standby current) is set by RCN2 2-15. This value of current can be calculated as follows:

$$\text{Standby Current Level (amps)} = 6 \left[\frac{1 \times 10^4}{\text{RCN2 } 2-15} \right]$$

where RCN2 2-15 is in ohms

The high current level (running current) involves the selection of RCN2 3-14 and RCN2 2-15 (determined above). The value can be calculated as follows:

$$\text{Running Current Level (amps)} = 6 \left[\frac{1 \times 10^4}{\text{RCN2 } 2-15} + \frac{1 \times 10^4}{\text{RCN2 } 3-14} \right]$$

where RCN2 2-15 and RCN2 3-14 are in ohms

NOTE: RCN2 1-16, RCN2 4-13, RCN2 6-11 and RCN2 5-12 are factory selected for the DM6006. These components should *never* be changed by the user.

The DM6006 is shipped with a standard personality module, which is defined by the resolution and rated phase current of the stepping motor being used. If the DM6006 is being used with a standard Aerotech stepping motor, the user need only define the desired resolution in which the motor is to operate. If the DM6006 is not being used with a standard Aerotech motor, the user must define the type of stepping motor being used, with its rated phase current, as well as the DM6006 resolution in which it is to operate.

A list of personality modules used with standard Aerotech stepping motors is listed after the following illustration. The label on the personality module defines the resolution (of the internal oscillators) and motor phase current parameters for that module. If the user is not using Aerotech motors, a custom personality module can be ordered using the part numbering format shown below. Given the rated current and resolution information for a particular motor, Aerotech will set the slew oscillators, the home oscillator and the Run/Standby phase current levels. Although it is not generally recommended, the user also has the option of changing the parameters of the personality module himself, using the equations listed in subsections H, I, J and K.

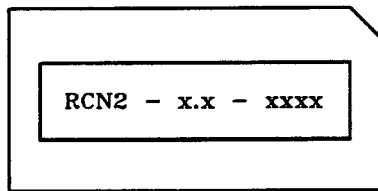

PERSONALITY MODULE RCN2

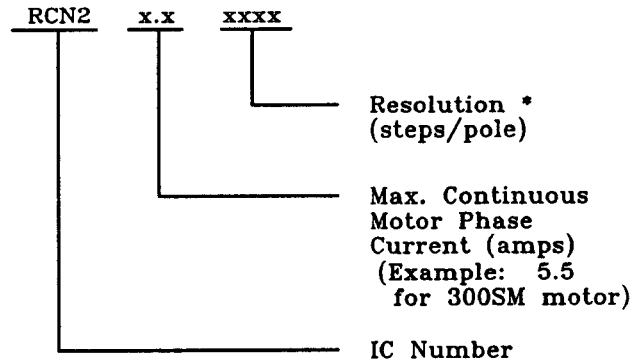

* This number defines the resolution (in steps per pole), for which the slew and home oscillator, as well as the current levels of the personality module, are "tailored" to operate.

Recommended standard RCN2 modules for the DM6006 are:

Aerotech Translator	Aerotech Motor	Phase Current (amps)	Torque (oz-in)	Recommended Personality Module (RCN2)
DM6006	200SM	4.7	200	RCN2 5.0 - xxxx
DM6006	300SM	5.5	350	RCN2 5.5 - xxxx

Contact Aerotech for Customized Personality Modules.

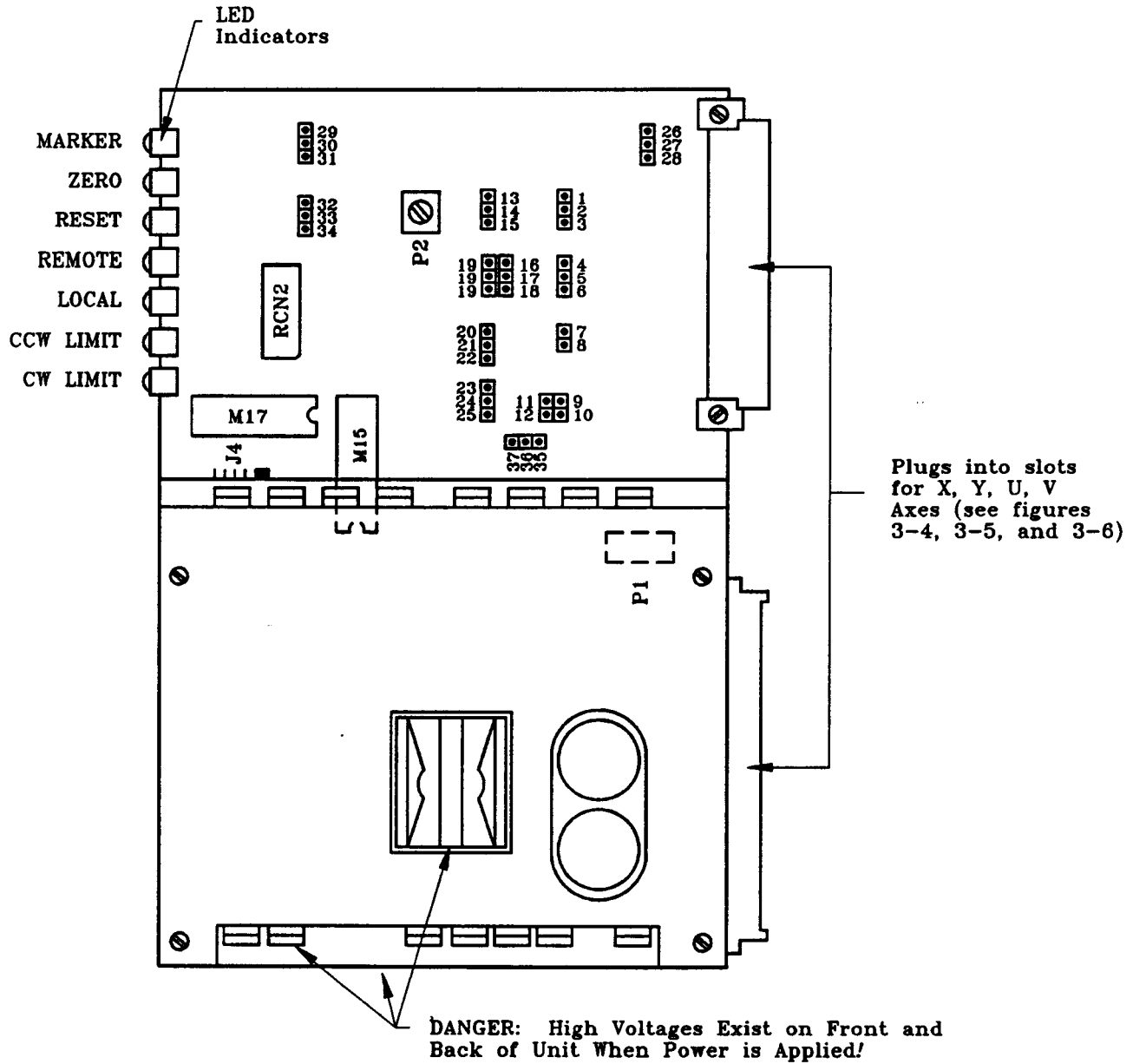

Figure 4-3: Outline of the DM6006 Stepping Drive Module

SECTION 4-4 DMV8008 AND DMV16008 DRIVE MODULES

A. CIRCUIT DESCRIPTION

The DMV8008 and DMV16008 are designed to accurately control a standard bipolar stepping motor by utilizing a unique sin/cos translator control. This control is capable of dividing a full- step size into 1000, evenly spaced micro steps. For a 50 pole (standard) stepping motor, this subdivision of a full step provides electrical resolutions of up to 50,000 steps per revolution. This sin/cos translator control, as mentioned in the introduction, can be easily altered to provide other step sizes. By simply programming two IC chips, a host of other incremental step sizes can be chosen, ranging from 200 steps/rev (full step) up to 50,000 steps/rev in 200 step intervals. In other words, there are 250 choices of stepping resolutions.

Unlike the D3001, D1401, DM1501, DM4001, DM4005 and DM6006 stepping motor drive module described in the previous sections, the DMV Series stepping drive modules require a DC bus power supply and $+5, \pm 12\text{VDC}$ control supply for operation. The external DC bus power supply, made up mainly of transformer T1 and/or T2 and capacitors C1 through C4 is shown in figures 3-4 and 3-5. A separate power supply board module (explained further in this chapter) is required for $+5, \pm 12\text{VDC}$ control power to the DMV Series module.

The DMV8008 can be used in Unidex 11 chassis U11S, U11R and U11H. The DMV 16008 is limited to use in the U11H chassis only. Note that in the case of the DMV16008, transformers T1 and T2 are not required if the incoming supply to the U11H chassis is 115VAC. The DMV16008 is operating "off line" in this particular case.

B. "HOME" REFERENCE DEFINITION & OPTIONS

All Unidex 11 controllers are capable of generating a cold start reference position, which is the "home" position. The basic home cycle involves the following series of events. When the "go home" command has been issued, the motor will turn CCW (standard) or CW (optional) until a "home limit switch" activation occurs (see section 2-2).

NOTE: The CCW and CW rotational references are viewed looking into the motor mounting flange.

Upon "home limit switch" activation, the motor will reverse and rotate in the opposite direction until the switch deactivates. If no "marker" pulse option exists, the motor will stop immediately. If a "marker" pulse option does exist (see section 4-4C), the motor will continue to rotate until the "marker" pulse is present. At this time, motion ceases.

The speed at which the home cycle occurs is factory set at 120RPM. If a different speed is required, see section 4-4H for appropriate personality module changes.

For most rotary motion stages, the "home limit switch" referenced above is an independent switch incorporated specifically for the "home" cycle. For linear motion stages, the "home limit switch" could be an independent switch as well. However, in most cases, the CCW or CW limit switches perform "double duty" and act as the "home limit switch". Note that the process of putting the "home limit switch" input in parallel with the CCW or CW limit switch input is standardly done at the motor/stage, external to the Unidex 11 (refer to chapter 5 and figure 5-3).

If it is not possible to use the "home limit" input at J13, 14, 19 or 20 (see section 2-2 A & B), such as when Opto 22 coupled limits are being used (see section 2-5), the "CCW" or "CW limit" input may be

paralleled to the "home limit" input by reconfiguring jumpers JP2-1 through 6 on the DMV16008/DMV8008 PC board. Note that this scheme is possible only with linear stages and not with rotary stages. The jumper definition follows:

HOME LIMIT SOURCE:

(Standard) From Home Limit Input: Jumper JP2-3 to 4 , Remove JP2- 1 to 2, JP2-5 to 6.

(Optional) From CCW Limit Input: Jumper JP2-1 to 2, Remove JP2-3 to 4, JP2-5 to 6.

(Optional) From CW Limit Input: Jumper JP2-5 to 6, Remove JP2-1 to 2, JP2-3 to 4.

See figure 4-4 for jumper locations.

When the home command is issued, the standard direction of motor rotation is CCW. If CW rotation is required, jumpers JP8-1 through 3 on the DMV16008/DMV8008 board must be reconfigured. The jumper definition follows:

(Standard) CCW Home - Jumper JP8-1 to 2, Remove JP8-2 to 3.

(Optional) CW Home - Jumper JP8-2 to 3, Remove JP8-1 to 2.

See figure 4-4 for jumper locations.

C. OUTLINE OF MARKER BUFFER CIRCUIT

Shown below is a circuit diagram of the differential input marker circuit:

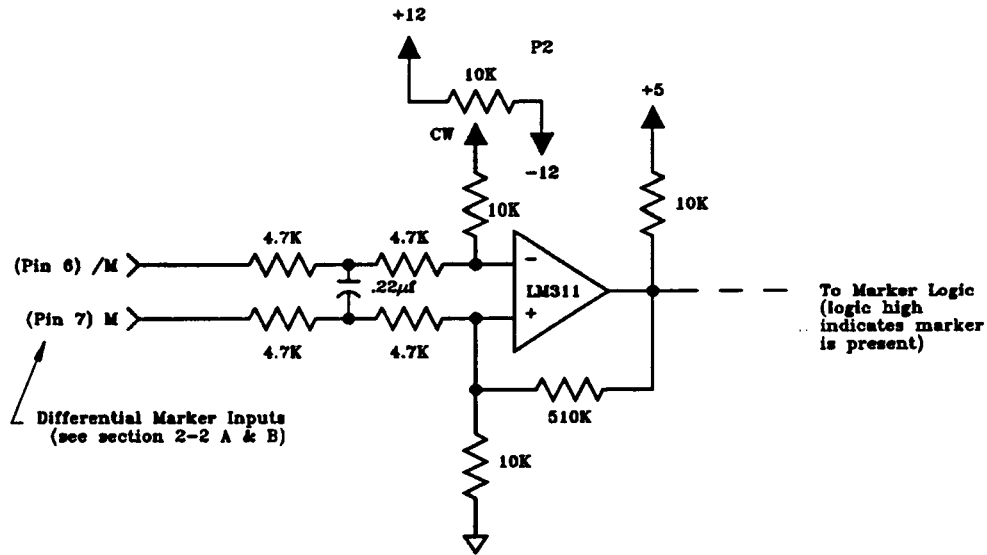

Potentiometer P2 (see figure 4-4) in the circuit diagram above allows the threshold of the marker input signal to be adjusted. The threshold level is increased by turning P2 CW. To activate the marker logic, the voltage signal at "M" must rise slightly higher than the voltage signal at "/M", plus the threshold setting at P2. In other words:

$$M > /M + P2 \text{ (threshold)}$$

For a TTL marker connection, the signal common of the TTL circuit should be tied to signal common with the marker tied to "M". P2 should be adjusted to approximately +1VDC at the P2 wiper.

NOTE: P2 will be factory set so that proper "home cycle" operation will occur when no marker pulse is present, or when interfacing to an Aerotech stage/motor with a "home marker" (HM) option. This setting is approximately -1VDC at the P2 wiper.

D. LIMIT SWITCH POLARITY SELECTION

As a standard, Unidex 11 controllers are configured to interface to normally open (active low) limit switches (CCW, CW and Home). If use of normally closed (active high) limit switches is required, jumpers JP3-1 through 3, JP4-1 through 3, and JP5-1 through 3 on the DMV16008/DMV8008 board must be reconfigured.

The jumper definitions follow:

(Standard) CCW Limit, Normally Open - Jumper JP3-1 to 2, Remove JP3-2 to 3.

(Optional) CCW Limit, Normally Closed - Jumper JP3-2 to 3, Remove JP3-1 to 2.

(Standard) CW Limit, Normally Open - Jumper JP4-1 to 2, Remove JP4-2 to 3.

(Optional) CW Limit, Normally Closed - Jumper JP4-2 to 3, Remove JP4-1 to 2.

(Standard) Home Limit, Normally Open - Jumper JP5-1 to 2, Remove JP5-2 to 3.

(Optional) Home Limit, Normally Closed - Jumper JP5-2 to 3, Remove JP5-1 to 2.

See figure 4-4 for jumper locations.

E. +/- DIRECTION DEFINITION & OPTIONS

When a "+" direction is programmed into a Unidex 11, the motor will rotate in the CW direction.

NOTE: Again, CW rotation is viewed as looking into the motor mounting flange.

When a "-" direction is programmed, the motor will rotate in the CCW direction. If the opposite convention is required, jumpers JP7-1 through 3 may be reconfigured. The jumper definition follows:

(Standard) "+" = CW, "-" = CCW - Jumper JP7-2 to 3, Remove JP7-1 to 2.
(Optional) "-" = CW, "+" = CCW - Jumper JP7-1 to 2, Remove JP7-2 to 3.

See figure 4-4 for jumper locations.

F. SELECTING STEPPING MOTOR RESOLUTION

The DMV Series modules can be programmed to drive a stepping motor at 250 different stepping resolutions. As was described in subsection A (*Circuit Description*), a stepping resolution range can be selected between 200 steps/rev and 50,000 steps/rev inclusive, in increments of 200 steps (i.e., 200, 400, 600,, 49600, 49800 and 50000 steps/rev).

The changing of resolution on the DMV Series involves the programming to two IC chips, M15 and M17 (see figure 4-4). This programming cannot be done in the field. However, M15 and M17 can be changed very easily in the field since both ICs are mounted on IC sockets.

The part numbering system for M15 and M17 is shown below. These part numbers must be used when ordering different control resolutions.

For IC M15:

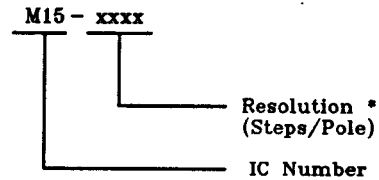
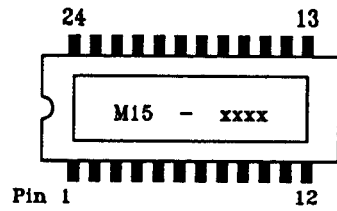

For IC M17:

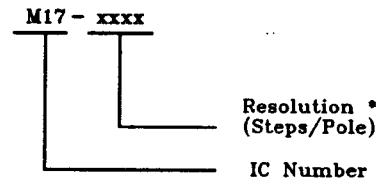
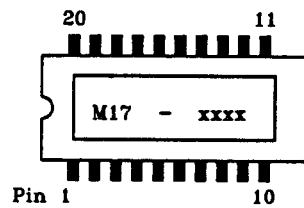

*** NOTE:** This number defines the resolution (in steps/pole).

For example:

**POLE RESOLUTIONS
(STEPS/POLE)**

1000	—————>	50000 Steps/Rev	For standard 1.8° /pole motors
720	—————>	36000 Steps/Rev	
80	—————>	4000 Steps/Rev	
16	—————>	800 Steps/Rev	

As was mentioned in the introduction to this manual, the step/rev numbers listed above apply to a 50-pole 1.8 degree per full step stepping motor. When determining step/rev for other multiple pole motors, multiply the given steps/pole resolution by the number of poles for the given stepping motor. The resulting number will then be the step/rev resolution for that motor.

G. PERSONALITY MODULE (RCN1)

The personality module is a 16-pin DIP wafer consisting of 4 resistors and 2 capacitors. This module contains all of the parameters used to match a given stepping motor with a given resolution for the DMV Series. A representation of a personality module is shown below (see also figure 4-4):

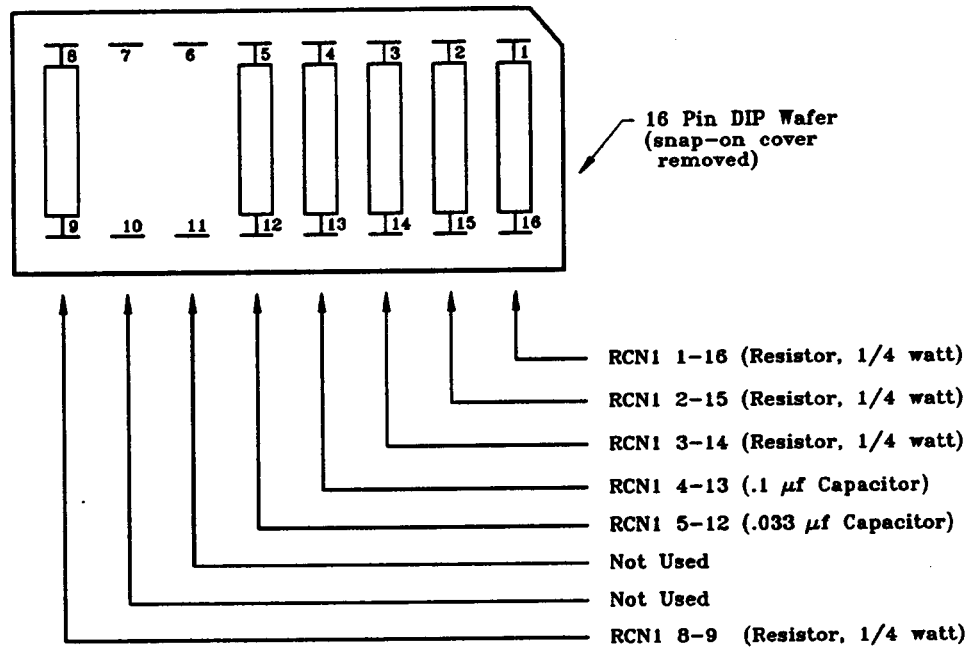

The parameter settings of RCN1 are explained in the following subsections.

H. RCN1 8-9, HOME CLOCK OSCILLATOR ADJUSTMENT

The adjustment for the oscillator which sends the stepping motor into a limit involves RCN1 8-9. This value can be determined as follows:

$$\text{Home Clock Frequency (Hz)} \sim \frac{1}{.75(.033 \times 10^{-6})(\text{RCN1 } 8-9)}$$

Where RCN1 8-9 is in ohms

I. RCN1 3-14 & 2-15, LO/HI CURRENT LVL ADJUSTMENT

The RCN1 low current level (standby current) is set by RCN1 2-15. This value of current can be calculated as follows:

$$\text{Standby Current Level (amps)} = 8 \left[\frac{1 \times 10^4}{\text{RCN1 } 2-15} \right]$$

where RCN1 2-15 is in ohms

The high current level (running current) involves the selection of RCN1 3-14 and RCN1 2-15 (determined above). The value can be calculated as follows:

$$\text{Running Current Level (amps)} = 8 \left[\frac{1 \times 10^4}{\text{RCN1 } 2-15} + \frac{1 \times 10^4}{\text{RCN1 } 3-14} \right]$$

where RCN1 2-15 and RCN1 3-14 are in ohms

NOTE: RCN1 1-16, RCN1 4-13 and RCN1 5-12 are factory selected for the DMV Series modules. These components should *never* be changed by the user.

The DMV Series modules are shipped with a standard personality module, which is defined by the resolution and rated phase current of the stepping motor being used. If the DMV Series is being used with a standard Aerotech stepping motor, the user need only define the desired resolution in which the motor is to operate. If the DMV Series is not being used with a standard Aerotech motor, the user must define the type of stepping motor being used, with its rated phase current, as well as the DMV Series resolution in which it is to operate.

A list of personality modules used with standard Aerotech stepping motors is listed below. The label on the personality module defines the resolution (of the internal oscillators) and motor phase current parameters for that module. If the user is not using Aerotech motors, a custom personality module can be ordered using the part numbering format shown in the following illustration. Given the rated current and resolution information for a particular motor, Aerotech will set the home oscillator and the run/standby phase current levels. Although it is not generally recommended, the user also has the option of changing the parameters of the personality module himself by using the equation listed in subsections H and I of this section.

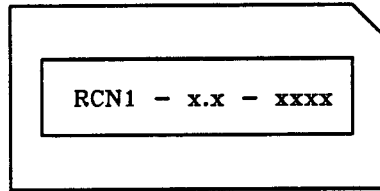

PERSONALITY MODULE RCN1

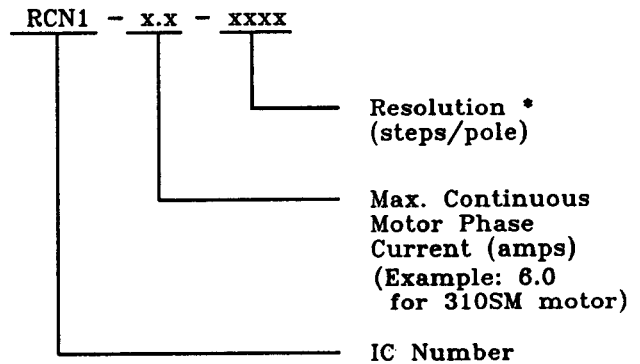

* This number defines the resolution (in steps per pole), for which the home oscillator, as well as the current levels of the personality module, are "tailored" to operate.

Recommended standard RCN1 modules for the DMV Series modules:

Aerotech Translator	Aerotech Motor	Phase Current (amps)	Torque (oz-in)	Recommended Personality Module (RCN1)
DMV8008	310SM	6	370	RCN1 6.0 - xxxx
DMV8008	510SM	8.6	520	RCN1 8.0 - xxxx
DMV16008	1010SM	8.6	1050	RCN1 8.0 - xxxx

Contact Aerotech for Customized Personality Modules.

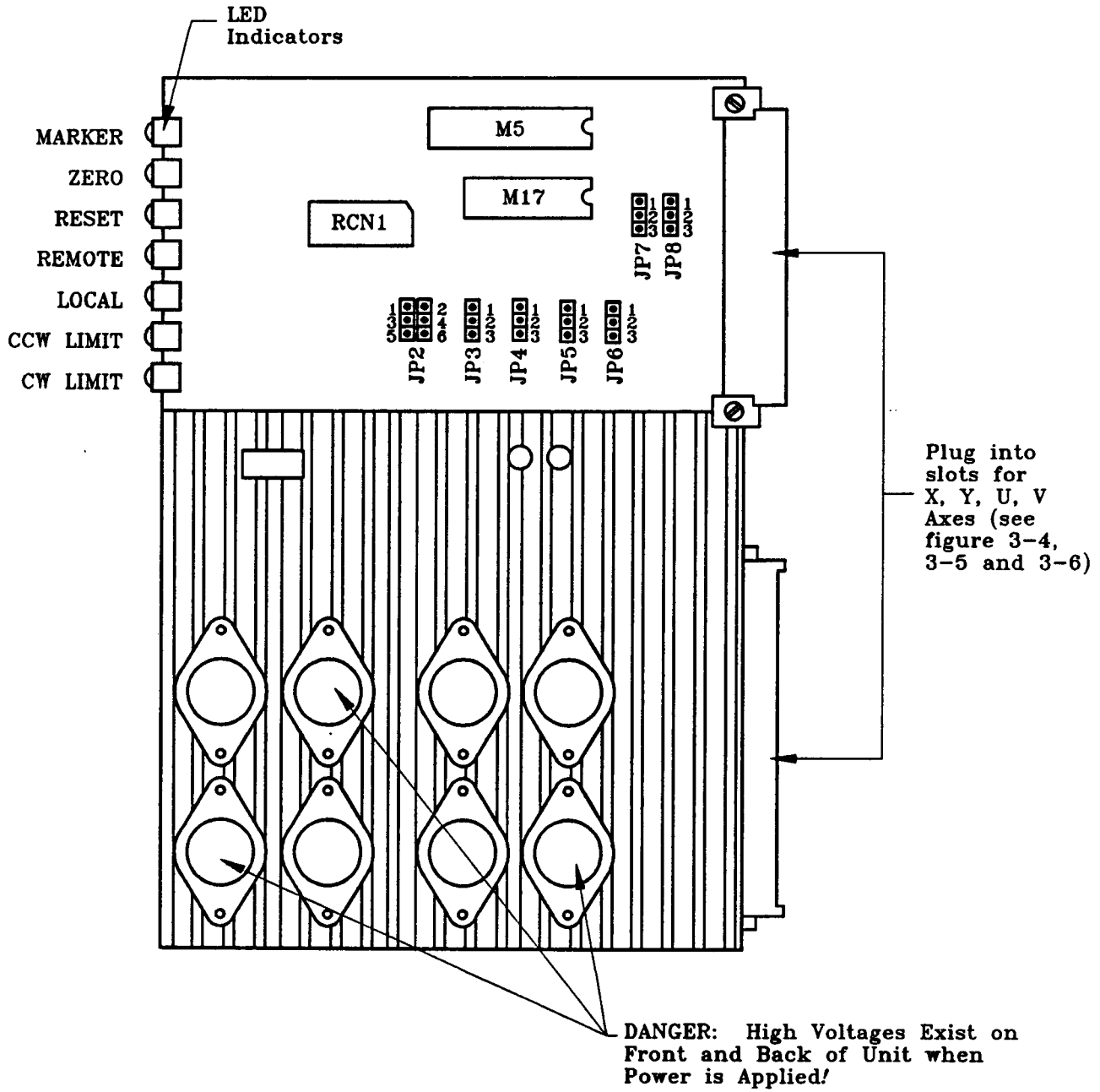

Figure 4-4: Outline of the DMV8008 and DMV16008 Stepping Drive Modules

SECTION 4-5 DSL8020 DRIVE MODULE

A. CIRCUIT DESCRIPTION

The DSL8020 has been designed to accurately control a standard DC brush servo motor with torque ranges of between 10 and 400 oz-in. This module runs the servo motor under closed loop control through an incremental square wave or amplified sine wave encoder. Position and velocity loops are both "closed" with circuitry contained on this module. Analog "position locking" can be obtained with the use of an amplified sine wave encoder for applications involving high "in-position" stability at varying load torques. Protection is included on this module for detecting "faulty" (or missing) encoder feedback signals or excessive position command to position feedback error. Emergency shutdown is automatic under these conditions.

Unlike the D and DM Series, stepping motor drive modules described in the previous sections, the DSL8020 DC servo drive modules require a DC bus power supply and +5, ± 12 VDC control supply for operation. The external DC bus power supply, made up mainly of transformer T1 and/or T2 and capacitors C1 through C4 is shown in figures 3-4 and 3-5. A separate power supply board module (explained later in this chapter) is required for +5, ± 12 VDC control power to the DSL8020 module.

The DSL8020 can be used in Unidex 11 chassis U11S, U11R and U11H.

B. DSL8020 OPERATION

The DSL8020 position control loop circuit works on the principle of command and feedback pulse summation. That is, CW and CCW command pulses are received from the control board module (described in the next section) and "summed" with the CW and CCW

feedback pulses derived from the incremental encoder. The summation technique involves decoding logic, a counter to sum the feedback and command pulses and a D/A converter (digital to analog) whose output represents the position error between the summation of the command and feedback pulses. The position error signal is used as a velocity command signal to the pre-amplifier (described later). In addition to the positive control circuit, (described above), an additional circuit is provided to "measure" the rate of CW and CCW feedback pulses per unit time in order to derive a representation for motor speed. The output of this circuit can be said to be a "electronically derived" velocity feedback signal from the motor. This circuit can also be configured to accept an optional tachometer.

For "locking" the in-position step (zero step) of the feedback encoder, a third circuit is provided to "hold" the DC motor firmly within a $\pm 1/2$ step of "zero step". This function is termed analog lock, and applies to sine wave type encoders only. The analog lock feature eliminates "zero bit" jitter when the motor is in the rest position and an external torque is being applied to its shaft.

A fourth circuit is provided on this board to "sum" the output signals of the three circuits just described. This circuit, labeled the "pre-amplifier" circuit, provides a signal as its output that is representative of the motor torque required to satisfy the position loop. This signal is actually the current command signal to the power amplifier portion of the DSL8020 (current drive directly proportional to torque). A block diagram of the four circuits just described above is shown next.

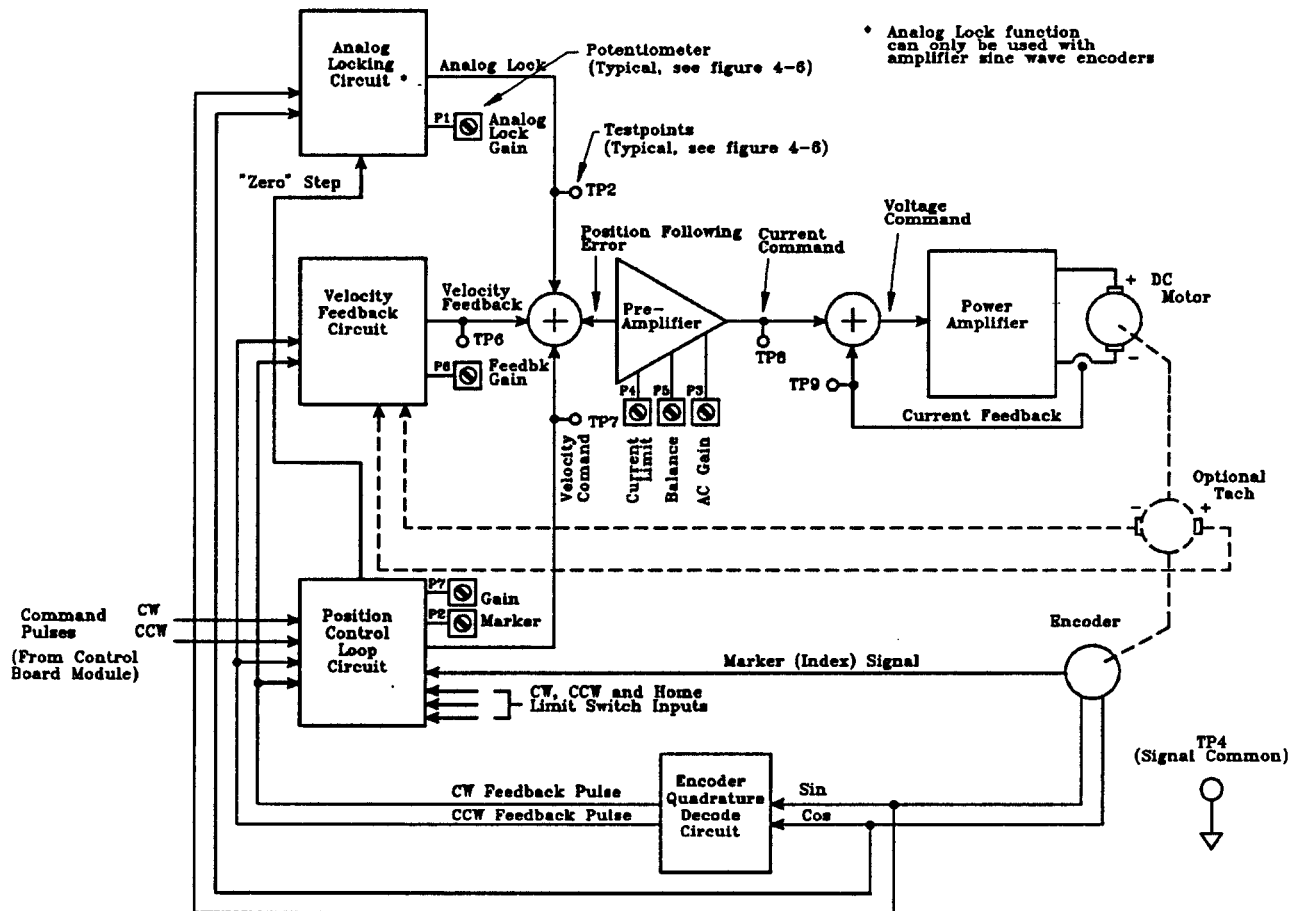

Figure 4-5: Block Diagram of DSL8020 Control Circuit

C. OPTIONAL TACHOMETER

For the DSL8020 to be used with the optional tachometer, it is necessary to reconfigure jumper JP11 and to remove .47 μ f lead capacitor at RCN5 3-14.

JP11	RCN5	
	3-14	
1-2	.47 μ f	Electronic Tach (standard)
2-3	Out	Analog Tach (optional)

D. MOTOR/ENCODER/TACHOMETER PHASING

If the motor, encoder, and/or optional tachometer is user supplied, it must be phased properly. *Improper phasing can cause loop instability or even a runaway condition to occur.*

Aerotech defines proper motor, tach, and encoder phasing with respect to CW motor rotation when viewed from the motor mounting flange. When a positive voltage is applied to the positive motor lead and a negative voltage to the negative lead, the motor will rotate CW. When the motor turns CW, this should cause the cosine to lead the sine encoder signal and the tach to generate a positive feedback voltage. For more information, see chapter 2.

E. MOTOR LOAD FUSE RATINGS FOR FUSE F1/CUR LIM

The motor load fuse is located on the bottom of the DSL8020 servo module (see figure 4-6). For Aerotech motors, the following fuse rating should be used.

Aerotech Motor	Motor Fuse F1	Current Limit
1017LT	4 amps	± 16 amps
1035LT	4 amps	± 16 amps
1050LT	5 amps	± 20 amps
1075LT	5 amps	± 20 amps
1135LT	5 amps	± 20 amps
1210LT	6 1/4 amps	± 20 amps
1410LT	8 amps	± 20 amps

NOTE: All fuses are 3AG type/slow-blow.

The motor fuse is sized according to the continuous current or torque rating of the motor and protects the motor from over-heating. The current limit setting of the DSL8020 is meant to limit peak current and is generally set to ±20 amps or four times the value of the motor fuse, whichever is less.

CAUTION: On smaller motors, due to the thermal time constant, the current limit setting is set at a much lower ratio. Check motor data sheets for actual value.

F. "HOME" REFERENCE DEFINITION & OPTIONS

All Unidex 11 Controllers are capable of generating a cold start reference position, which is the "home" position. The basic "home" cycle involves the following series of events. When the "Go Home" command is issued, the motor will turn CCW (standard) or CW (optional) until a "home limit switch" (see section 2-2) activation occurs.

NOTE: The CCW and CW rotational references are viewed looking into the motor mounting flange.

Upon "home limit switch" activation, the motor will reverse and rotate in the opposite direction until the switch deactivates. The motor will continue to rotate until the "marker" pulse is present. At this time motion ceases.

The home speed is determined by the value of the RCN5 6-11 resistor and will vary, depending on the system resolution.

Rotary Encoder (Steps/Rev)	Linear Encoder (Steps/mm)	Frequency	RCN5 6-11
200	50	2.5kHz	20K
400	100	5.0kHz	10K
1000 & up	250 & up	10.0kHz	5.1K

For most rotary motion stages, the "home limit switch" referenced above is an independent switch incorporated specifically for the "home" cycle. For linear motion stages, the "home limit switch" could be an independent switch as well. However, in most cases, the "CCW" or "CW limit switches" perform double duty and act as the "home limit switch". Note that the process of putting the "home limit switch" input in parallel with the "CCW" or "CW limit switch" input is standardly done at the motor/stage, external to the Unidex 11 (reference chapter 5 and figure 5-3).

It is not possible to use the "home limit" input at J13, 14, 19 or 20 (see section 2-2 A & B), when Opto 22 coupled limits are being used (see section 2-6). When used in this fashion, "CCW" or "CW limit" input may be paralleled to the "home limit" input by reconfiguring jumper JP3 on the DSL8020 PC board. The jumper definition is as follows:

JP3 HOME LIMIT SOURCE:

(Standard) From Home Limit Input: Jumper JP3-3 to 4 , Remove JP3- 1 to 2, JP3-5 to 6.

(Optional) From CCW Limit Input: Jumper JP3-1 to 2, Remove JP3-3 to 4, JP3-5 to 6.

(Optional) From CW Limit Input: Jumper JP3-5 to 6, Remove JP3-1 to 2, JP3-3 to 4.

See figure 4-6 for jumper locations.

When the home command is issued the standard direction of motor rotation is CCW. If CW rotation is required, jumper JP1 on the DSL8020 board must be reconfigured.

JP1 HOME DIRECTION JUMPER:

(Standard) CCW Home - Jumper JP1-2 to 3, Remove JP1-1 to 2.

(Optional) CW Home - Jumper JP1-1-2, Remove JP1-2 to 3.

See figure 4-6 for jumper locations.

G. MARKER INPUT CIRCUIT

Shown below is a circuit diagram of the differential input marker circuit:

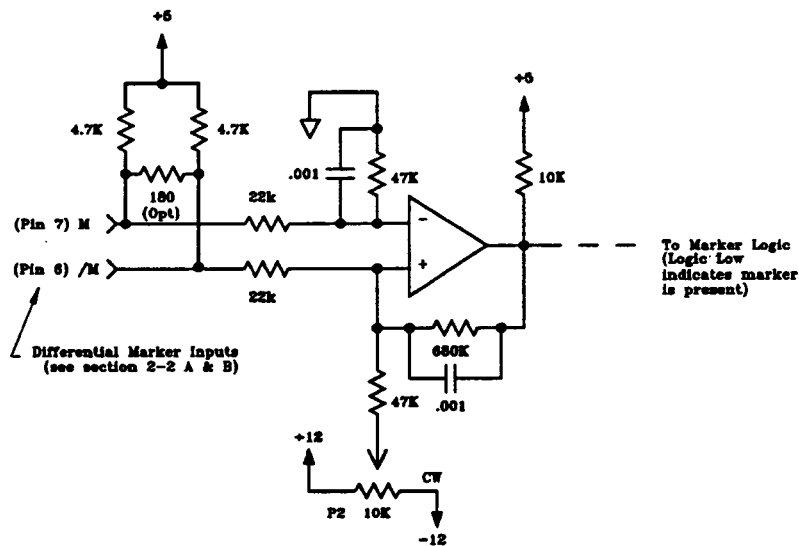

Potentiometer P2 in the circuit diagram above allows the threshold of the marker input signal to be adjusted. The threshold level is increased by turning P2 CCW. To activate the marker logic, the voltage signal at "M" must rise slightly higher than the voltage signal at "/M", plus the threshold setting at P2. In other words:

$$M /M + P2 \text{ (threshold)}$$

For a TTL marker connection, the signal common of the TTL circuit should be tied to signal common with the marker tied to "M". P2 should be adjusted to approximately +1VDC at the P2 wiper.

H. LIMIT SWITCH POLARITY SELECTION

As a standard, Unidex 11 controllers are configured to interface to normally open (active low) limit switches (CCW, CW and Home). If use of normally closed (active high) limit switches is required, jumpers JP2, JP4, and JP5 on the DSL8020 board must be reconfigured. The jumper definitions follow:

LIMIT/LIMIT-N JUMPERS (JP2, JP4, JP5)

(Standard) CCW Limit, Normally Open - Jumper JP5-2 to 3, Remove JP5-1 to 2.

(Optional) CCW Limit, Normally Closed - Jumper JP5-1 to 2, Remove JP5-2 to 3.

(Standard) CW Limit, Normally Open - Jumper JP2-2 to 3, Remove JP2-1 to 2.

(Optional) CW Limit, Normally Closed - Jumper JP2-1 to 2, Remove JP2-2 to 3.

(Standard) Home Limit, Normally Open - Jumper JP4-2 to 3, Remove JP4-1 to 2.

(Optional) Home Limit, Normally Closed - Jumper JP4-1 to 2, Remove JP4-2 to 3.

See figure 4-6 for jumper locations.

I. ENCODER MULTIPLICATION PARAMETERS

Incremental encoders produce two output signals generally referred to as sine and cosine. These signals are displaced 90 degrees with respect to each other (i.e., in quadrature with respect to each other). These quadrature signals can be in the form of either amplified sine

waves or square waves. (The amplified sine wave type being applicable to analog lock control.)

Through electronic decoding logic on the DSL8020, these quadrature signals can be interpreted as providing 1, 2 or 4 individual steps (machine steps) per our full cycle of sine and cosine.

Multiplying the encoder signal by 1, 2, or 4 (X1,X2,X4), involves the manipulation of jumpers and, in case of amplified sine wave encoders, the changing of resistor values on the encoder interface module (see figure 4-6). For square wave encoder operation, only jumpers on the main board must be selected.

ENCODER MULTIPLICATION	MULTIPLIER	R5	R6	R7	R8	JUMPER	JUMPER JP7	JUMPER JP6	JUMPER JP19	JUMPER JP18
SINE WAVE 690C1333	X1	22K	OUT	OUT	43K	2-3	2-3	2-3	2-3	2-3
	X2	22K	OUT	OUT	43K	2-3	2-3	1-2	2-3	2-3
	X4	OUT	43K	22K	OUT	1-2	1-2	2-3	2-3	NONE
SQUARE WAVE 690C1334	X1	(No change)	(No change)	(No change)	(No change)	(No change)	2-3	2-3	2-3	2-3
	X2						2-3	1-2	2-3	2-3
	X4						1-2	2-3	2-3	NONE
Encoder Interface Module							Main Board (DSL8020)			

NOTE: Changing resolution will also change system gain. For optimum performance, it may be necessary to change the accel/decel parameter and/or the gain setting of the DSL8020.

J. ADJUSTMENTS

Seven potentiometers and six test points are provided on the DSL8020 servo module. A description of these pots and test points are as follows (refer to figures 4-5 and 4-6).

P1

ANALOG LOCK GAIN ADJUST

This pot adjusts the sine lock gain for analog lock in the "zero" step (rest) position. This pot is applicable to sine wave encoders only. This pot *must* be turned to the full CW position when using square wave type encoders. Analog lock is adjusted by monitoring testpoint TP2 (with respect to signal common, TP4) and the zero LED indicator. Turning P1 CCW increases the analog lock gain.

When the motor is at rest (no command pulses), the "zero" LED indicator must first be set to energize by adjusting the balance pot P5 (discussed below). When the zero LED is energized, the analog lock testpoint (TP2) should be monitored (with an oscilloscope) and both the balance pot P5 and the analog lock pot P1 should be adjusted until TP2 reads close to zero volts.

P2

MARKER ADJUST

This pot adjusts the threshold of the marker (index) input pulse from the incremental encoder (see marker input circuit, section 4-5G).

P3

AC GAIN ADJUST

This pot adjusts the AC gain of the pre-amplifier. Potentiometer P7 and P6 affects the DC as well as the AC gain of the pre-amplifier as discussed below. Turning the AC gain pot (P3) CCW increases the AC gain of the pre-amplifier.

P4

CURRENT LIMIT ADJUST

This pot adjusts the clamping level of current applied to the servo module through the power stage of the DSL8020. The full CCW position allows maximum current. The full CW position clamps the current command to zero (no motor current). The current command signal can be monitored at test point TP8.

The motor current feedback signal, which is summed with the current command signal to produce a voltage command signal to the power amplifier (see figure 4-5), can be monitored at testpoint TP9.

Both the current command and current feedback testpoints (TP8 and TP9 respectively) provide signal gain ratio of ± 3 amps per volt.

The summation circuitry for current feedback and current command (specifically an integral-lead circuit) provides a motor current bandwidth of approximately 1000 Hz (assuming a 2 - 5 milliHenry load inductance).

P5

BALANCE POT

This pot adjusts analog offsets inherent in the pre-amplifier circuit (see figure 4-5) which can cause position error. This pot is adjusted when the DC motor is at rest. The zero LED indicator should be viewed while adjusting this pot when the motor is at rest. The "zero" step condition is present, meaning that the number of feedback pulses has been registered with respect to the amount of command pulses applied.

P6

VELOCITY FEEDBACK GAIN

This pot adjusts the amount of DC velocity feedback gain to the pre-amplifier. Velocity feedback is electronically derived from the encoder or from an optional tachometer (see figure 4-5). Velocity feedback has two purposes. First, to provide "damping" to the position control loop to eliminate position loop oscillation. Secondly, the velocity feedback provides a means of generating position "following error" in the position loop. Following error provides the desirable effect of eliminating position "overshoot" when operating the motor at high accel/decel rates. Testpoint TP6 provides a monitor for the velocity feedback signal. Turning this pot CW increases velocity feedback gain and typically reduces motor positioning response.

P7

COMMAND GAIN

This pot adjusts the amount of DC velocity command gain to the pre-amplifier. Command velocity is derived from the accumulated difference (or error) between the command pulses from the control board module (discussed in section 4-7) and the feedback pulses generated by the encoder. Testpoint TP7 provides a monitor for the velocity command signal. The ratio of the voltage of this signal with respect

to actual command motor velocity varies with the encoder resolution and the setting of the velocity feedback gain described above, and therefore cannot be directly defined.

NOTE: Adjustment of the command velocity gain pot (P7) and feedback velocity gain pot (P6) may require that the balance pot (P5) be readjusted to obtain the "zero" step condition discussed earlier.

K. ADJUSTING POSITION & VELOCITY LOOP

The DSL8020(s) is factory adjusted for the given Aerotech DC servo motor(s) (i.e., 1050LT, 1135LT, etc.) shipped with the Unidex 11. *If a user-supplied motor and encoder is to be used with Unidex 11, Aerotech should be notified of the motor and encoder parameters at the time of purchase to insure compatibility and proper factory set up.*

If the motor, encoder and translation stage are user supplied, the following adjustment procedure is recommended:

NOTE: An oscilloscope is required for the following procedure.

- 1) If the motor, encoder and optional tachometer are one assembly, disconnect from the load if possible.
- 2) With power turned off, rotate motor CW (as viewed from the motor mounting flange), and check motor polarity. A positive voltage can be measured from the positive terminal with respect to the negative terminal of the motor (see chapter 2).
- 3) **REMOVE MOTOR FUSE** (see figure 4-5), connect oscilloscope common to TP4 (signal common), channel 1 probe to TP3 (cosine square) and channel 2 probe to TP5 (sine square).

For the placement of testpoints and motor fuse, see figure 4-6. Apply power, manually turn motor CW and check phasing of encoder signals at TP3 and TP5 (see chapter 2). Note that signals at TP3 and TP5 will always be square wave signals, even if sine wave encoders are used. Also check for a positive velocity feedback voltage at TP6 while turning the motor CW.

- 4) Turn off power, replace motor fuse (see section 4- 4E for fuse ratings), and turn P1 full CW, P3 full CW, P4 full CW (minimum current limit), P5 mid-range, P6 full CW, and P7 full CCW. This should set the gain and current limit setting to their lowest adjustable value. Apply power and slowly adjust the current limit adjustment, P4 CCW and observe system. If system is stable, turn P4 full CCW, ± 20 amps, or adjust to desirable level by monitoring TP9, current feedback testpoint (3 AV) while running a program.
- 5) Write a small program that will run Unidex 11 back and forth with a 1-second dwell in between moves. Set the feedrate for 1/2 of the maximum system speed. Set the accel/decel rate to 100mS, linear profiling. Set the motion format to "corner-rounding" mode. In the corner-rounding mode, the Unidex 11 will not wait for the "in-position" signal before contouring as commanded by the next command in the program. Make certain that the move is long enough to affirm that the motor can accelerate and run at programmed speed.
- 6) Replace the motor fuse, apply power, and run the program detailed in step 5. Adjust P7 (command gain adjustment) CW for less than or equal to $\pm 4V$ of following error at TP7 with respect to TP4 (signal common). If the motion stops and "axis in limit" error message appears on the Unidex 11 display, this means that you have gone beyond the range of the D/A. If this is the case, turn P7 more CW, and turn power off, then on again, to clear fault condition and try again. If you do not have enough range with P7, then turn P6 (velocity feedback) CCW to decrease following error.

If "axis in limit" error message persists, the problem may be due to one of the following:

- a) The requested program speed exceeds the capabilities of the motor and amplifier.
- b) There may not be enough acceleration torque available to accelerate the motor and/or load up to speed. If this is the case, it may be necessary to increase the accel/decel parameter from 100 mS to 200 mS.

- 7) If you disconnected the load in step 1, reconnect it now.
- 8) Turn AC gain adjustment, P3, CCW, until the system starts to oscillate. Then adjust P3 CW 1/8 turn past the point where it stops oscillating.
- 9) The system should now be stable and the gain adjustments very conservatively set (over damped). At this point the system should be running the program from step 5 very smoothly. However, to optimize positioning time, run the program from step 5 at maximum system speed and turn P7 (command gain) more CW, to achieve the results at TP7 (velocity command) as shown in diagram 4-1. If you do not have enough range with the P7 adjustment, it may be necessary to turn P6 (velocity feedback gain) more CCW. However, you must remember that if you adjust P6 you will also have to readjust P3 (AC gain) by following the description in step 8, (or by viewing the results at TP6 while running your program).
- 10) Decrease the accel/decel value from 100mS until you start to notice overshoot at TP7 (velocity command).
- 11) To adjust the balance for a square wave encoder system, send the axis to the "home position" and adjust P5 (balance adjustment) until both the "marker" and the "zero" indicator LEDs on the Unidex 11 front panel are energized.

To adjust the balance for a sine wave encoder system, it will be necessary to adjust the P1 (analog lock gain) and P5 (balance adjustment). When the system

is at rest, adjust P5 until the "zero" indicator LED is lit on the front panel of the Unidex 11. Connect the probe of the oscilloscope to TP2 (lock signal) and the common of the oscilloscope to TP4 (signal common). Turn P1 (analog lock gain) mid-range and adjust P5 (balance) for zero volts ($\pm .5V$) at TP2. Execute a one step move and adjust P1 for approximately 25% overshoot at TP2 upon completion of the move with little or no ringing (as shown in diagram 4-2). After adjusting P1 it may also be necessary to readjust P5 once again.

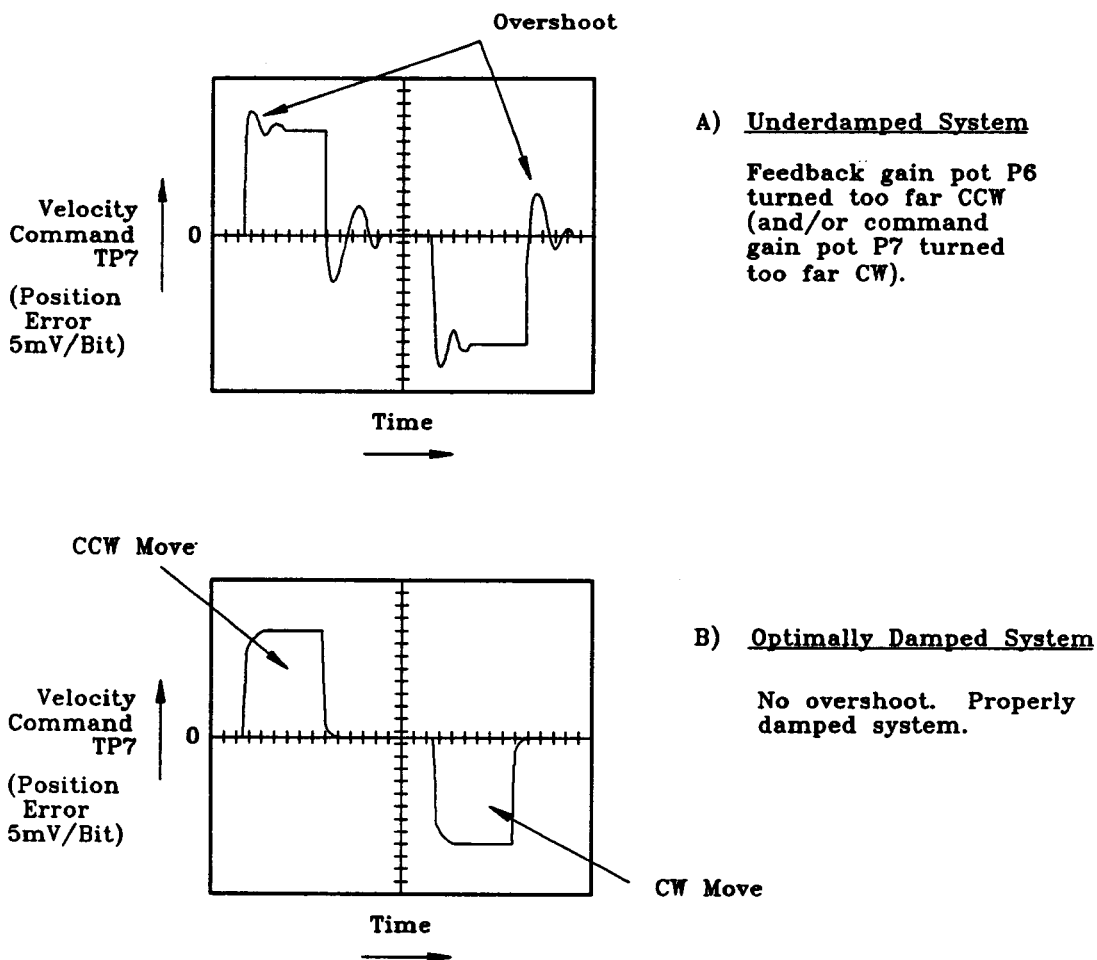
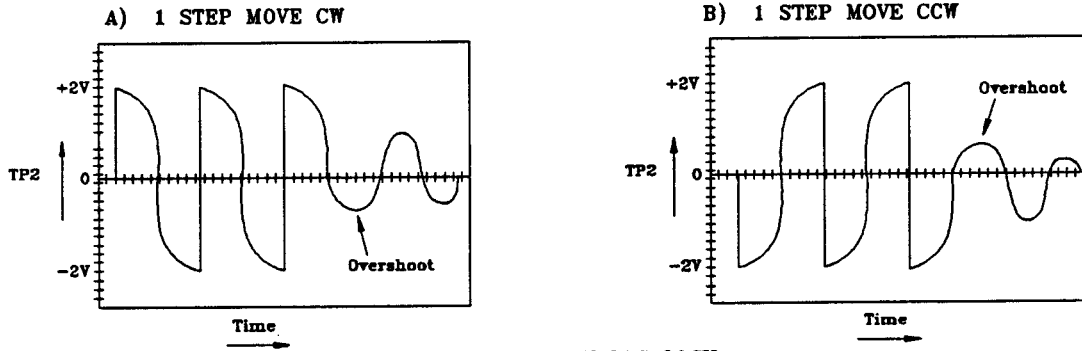

Diagram 4-1: Velocity Command refers to TP7 for Underdamped (A), and Optimally Damped (B), Position Loop Response

NOTE: The velocity command shown in diagram 4-1 also represents the position error which is scaled to a 5mV/machine step.

X1 RESOLUTION ANALOG LOCK



X2 RESOLUTION ANALOG LOCK

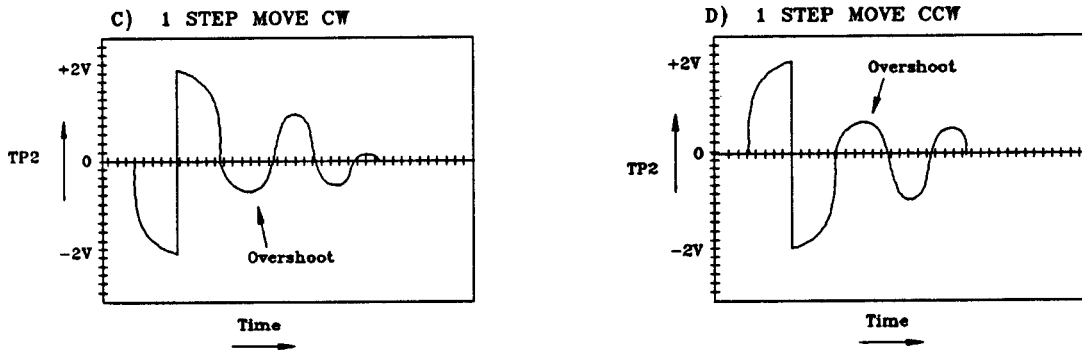

X4 RESOLUTION ANALOG LOCK

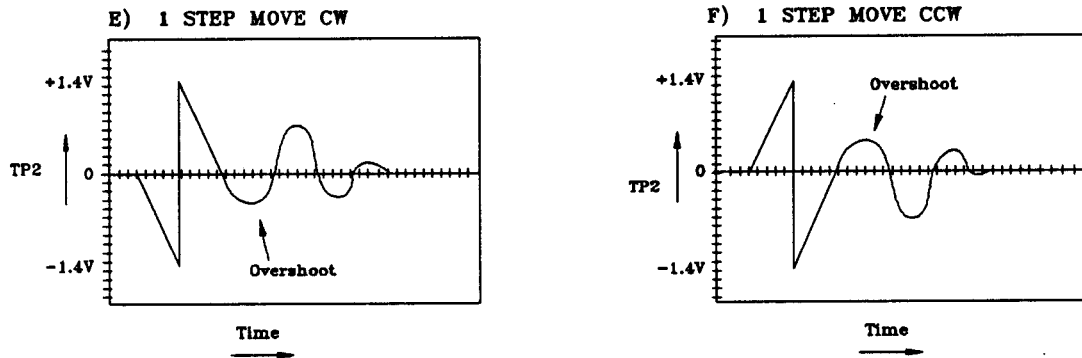

Diagram 4-2: Analog Lock Signal at TP2 for X1,X2 and X4 Resolution (shown for Sine Wave Encoders only)

The DSL8020 is Now Ready for Operation

Before programming normal motion, slew the motor (at a very low velocity) into the CW travel limit switch and CCW travel limit switch. Be certain that the CW and CCW limit LEDs energize in their proper sequence and that Unidex 11 responds by stopping motion *before* the motor reaches its mechanical end stop (normally a minimum distance of one motor revolution should exist between the respective limit switch activating point and the mechanical end stop).

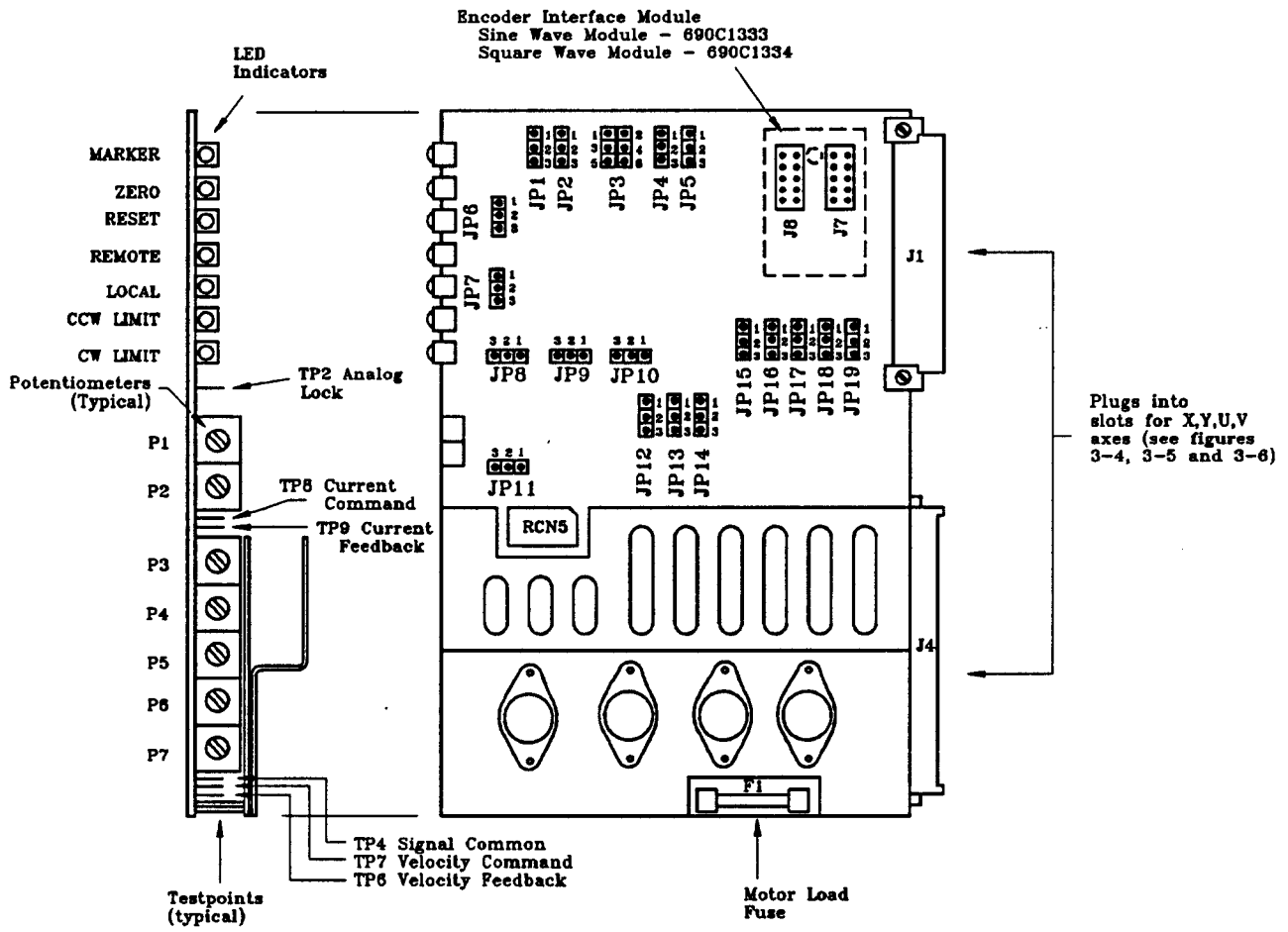

Figure 4-6: Outline of the DSL8020 DC Servo Drive Module

SECTION 4-6 POWER SUPPLY BOARD

A. CIRCUIT DESCRIPTION

The power supply board (module) is provided for use with the DMV16008 and DMV8008 stepping drive modules as well as the DSL8020 servo drive module. This module provides +5VDC and ± 12 VDC control voltages to the DMV and DSL drive modules (note that D3001, D1401, DM1501, DM4001, DM4005 and DM6006 stepping drive modules do not require this board for control power generation since all control and motor supply voltages are generated on the board).

An outline of the power supply board is shown in figure 4-7.

A DC shunt regulator circuit is also provided on the power supply board to clamp excessive regenerative energies present when motors with high inertia loads are decelerating. The shunt regulator can only accommodate one DC bus power supply (see figure 3-1 and 3-2). Referring to figures 3-1 and 3-2, the power supply board (which plugs into slot P5) can shunt only the power supply associated with drive module slot P4. If P3, P2 and P1 share the same supply as slot P4, these slots also share shunt regulation.

The shunt regulator circuit is factory set to work with DC Bus voltages of ≤ 80 V or 160V (DMV16008 only).

Referring to figure 4-7, it can be noted that eight testpoints are provided as monitor points for the user. These testpoints are described as follows:

TP5	+5VDC (for encoders, optical markers, or optical limit switches)
-----	--

TP6	+5VDC (for DMV and DSL Series drive modules)
TP8	+12VDC (for DMV and DSL Series drive modules)
TP7	-12VDC (for DMV and DSL Series drive modules)
TP4	Signal common
TP1	+DC bus voltage (shunt regulator bus voltage)
TP3	+DC bus voltage return (reference point for shunt regulation)
TP2	Shunt regulation switching reference

The voltage at which the shunt regulator circuit begins to function (the shunt voltage threshold) is adjustable via potentiometer P2 (see figure 4-7). This pot is set at the factory for a threshold of 95 VDC for all bus voltages of 80V or less, and for a threshold of 185VDC for a bus voltage of 160VDC.

If it is necessary to change these settings, the shunt regulator threshold can be readjusted by monitoring TP2 with respect to TP3. The voltage on TP2 will switch between the given bus voltage and zero when the shunt voltage threshold is reached. Turning P2 CCW decreases the voltage threshold point, and turning P2 CW increases the voltage threshold point. The range of P2 adjustment is from 80VDC to 200VDC. The shunt voltage threshold is typically adjusted by first accelerating and decelerating all motors simultaneously at full speed while monitoring TP2. The regenerative bus voltage level should not be allowed to exceed 20% of the rated drive voltage while the motors are decelerating. Note that excessive shunt regulation will cause F5 to open.

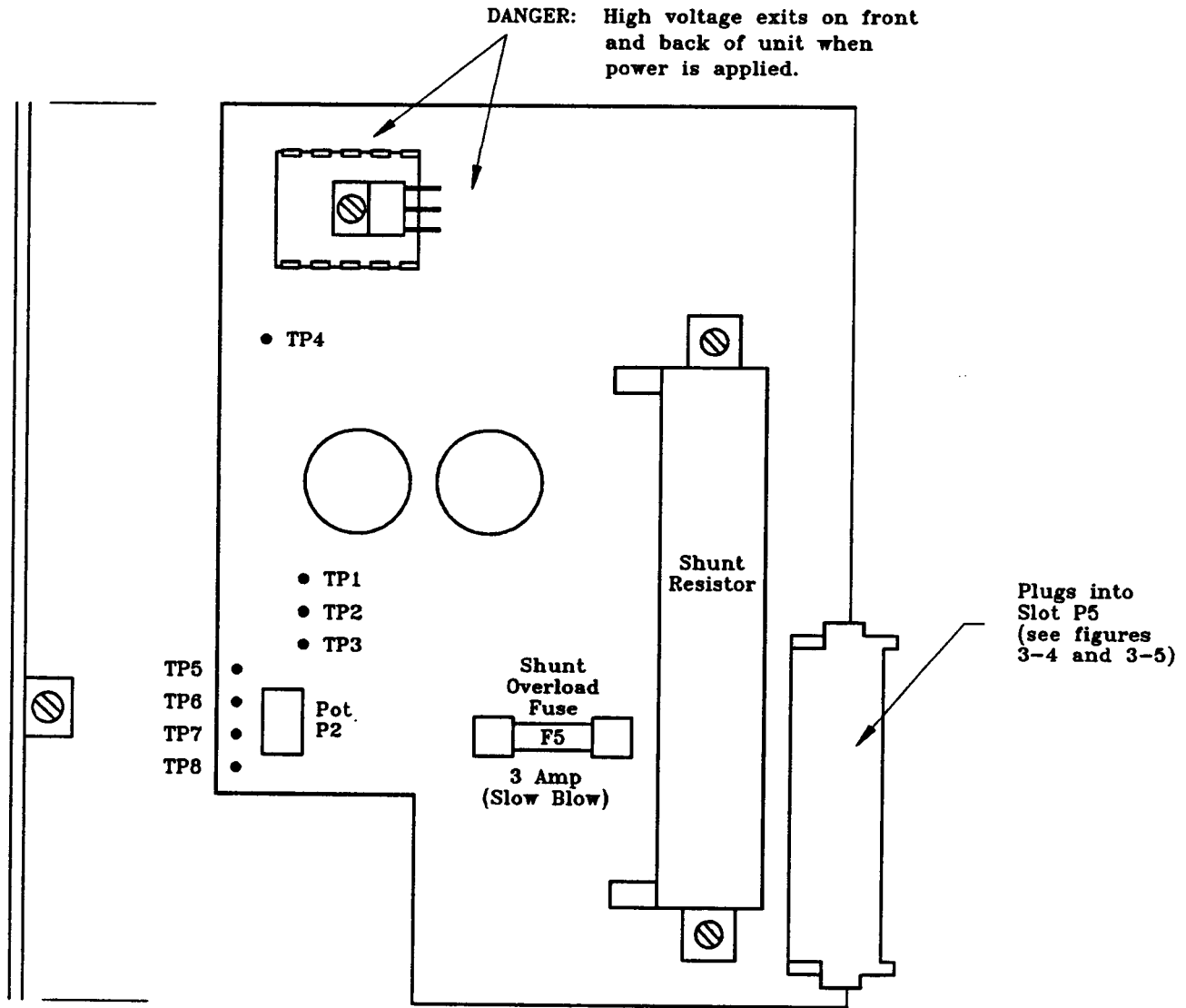

Figure 4-7: Outline of the Power Supply Board Module

SECTION 4-7: CONTROL BOARD

A. CIRCUIT DESCRIPTION

The control board is the "intelligence" of the Unidex 11 family of controllers. The control board provides the interface between the user generated commands (through the front panel keypad and displays, or RS-232/IEEE-488 interface) and the motion generating drive modules discussed previously.

An outline of the control board is shown in figure 4-8. This outline shows the position of the system operating ROMs (Read Only Memory). There are two ROMs, one on the top extension board and one on the base (or primary) board. These ROMs are labeled M3 and M2 respectively. The system operating RAM (Random Access Memory) is located on the base board and is labeled M3.

Figure 4-9 shows the outline of the top Extension Board only. This board contains the interface hardware for the RS-232 or IEEE-488 options. Only one of these two options can be active. If RS-232 is active, the following "chips" will be installed on the Extension Board:

M12 - MC68661PB, Aerotech #ECS236
M15 - MC1488P, Aerotech #ECS113
M16 - MC1489, Aerotech #ECS114

If IEEE-488 is active, these alternate "chips" will be installed on the Extension Board:

M21 - MC68B488P, Aerotech #ECS358 85
M22,M23,M27,M28 - AM3448AP, Aerotech #ECS206

In addition to these differences, the correct interface connector on the Unidex 11 rear panel must be installed (see chapter 2). J2 is the RS-232 interface and J15 is the IEEE-488 interface.

CAUTION: If a system is set-up and active for RS-232 communications, an IEEE-488 device must not be connected at the Unidex 11 rear panel. If a system is set-up for IEEE-488 communications, an RS-232 device must not be connected at the Unidex 11 rear panel. Damage to the Unidex 11 and to the communicating device will occur if this instruction is not followed!

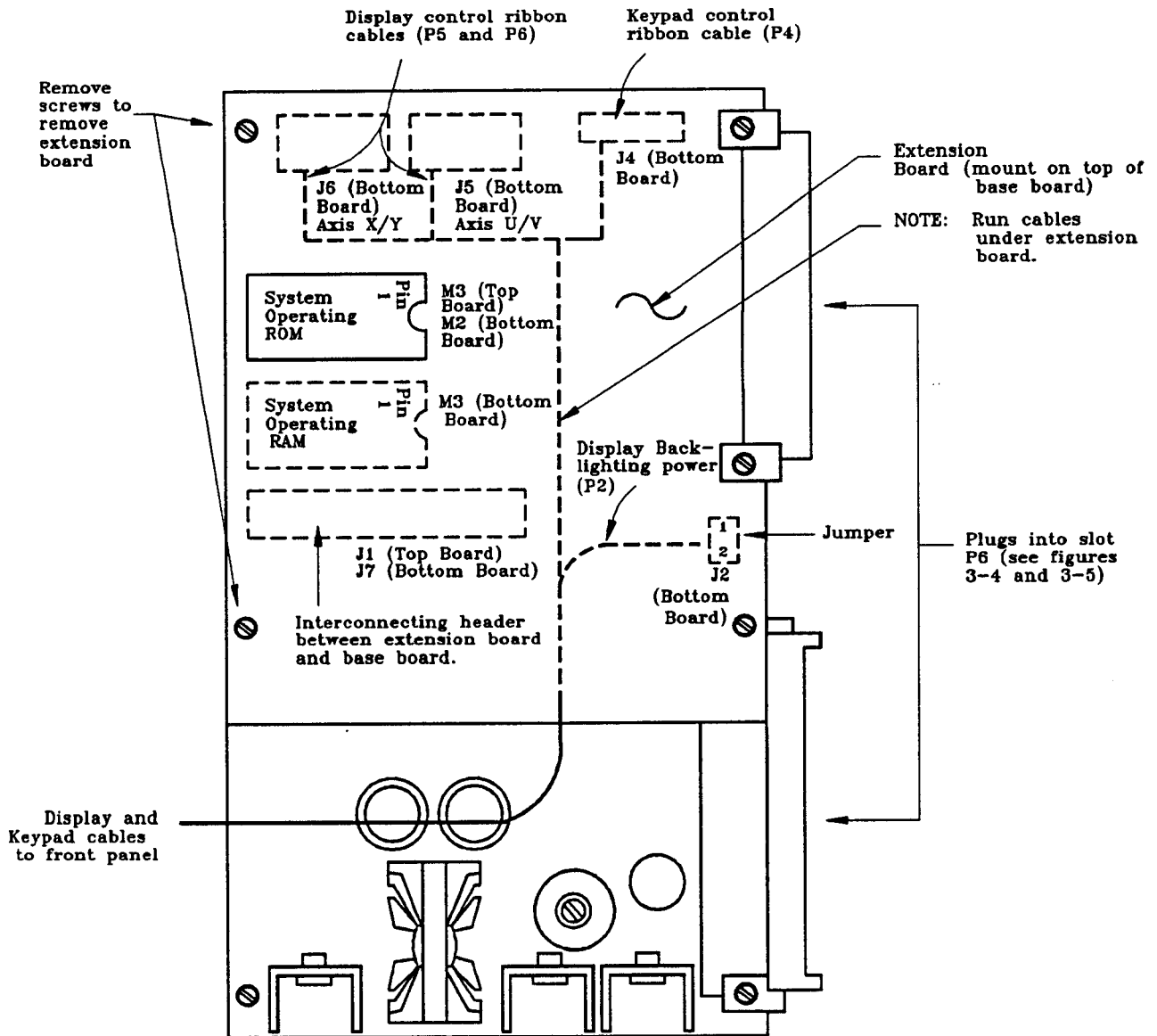
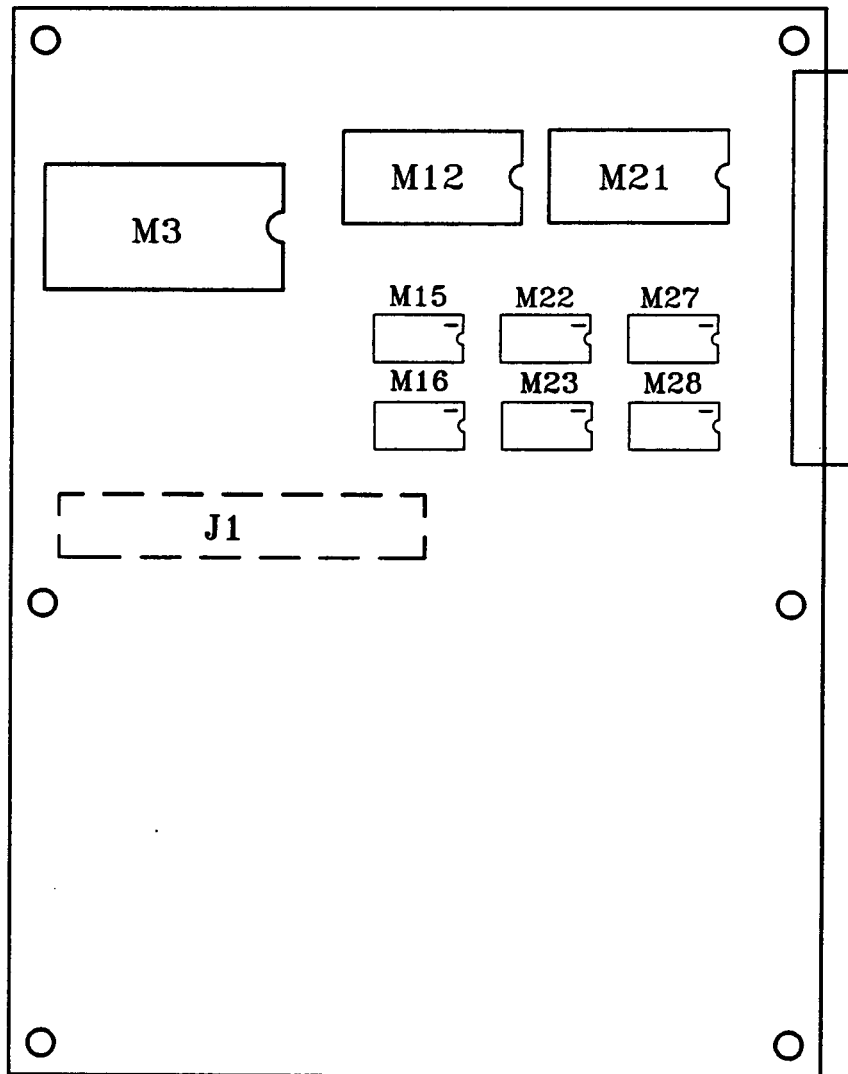

Figure 4-8: Outline of the Unidex 11 Control Board



For IEEE-488, install M21, M22, M23, M27, M28
For RS-232, install M12, M15, M16

Figure 4-9: Outline of the Unidex 11 Control Board, Extension Board

CHAPTER 5: STEPPING AND DC SERVO MOTORS

SECTION 5-1 HARDWARE SPECIFICATIONS

Dimensional data for stepping motors and DC servo motors used with the Unidex 11 family of controllers is illustrated in this section.

Figure 5-1 shows dimensional data for the DC servo motors and figure 5-2 shows dimensional data for the stepping motors used with the Unidex 11 controllers. Detailed mechanical data such as shaft lengths and shaft keying are not shown in these figures. This data is supplied in separate documents.

Figure 5-3 shows pin-out assignments for the limit switch interface board associated with most of the motors illustrated in figures 5-1 and 5-2.

Figure 5-4 provides dimensional data for the Unidex 11 control enclosures.

CHAPTER 5: STEPPING AND DC SERVO MOTORS

MSO1 - 1017LT, 1035LT, 1050LT Motors

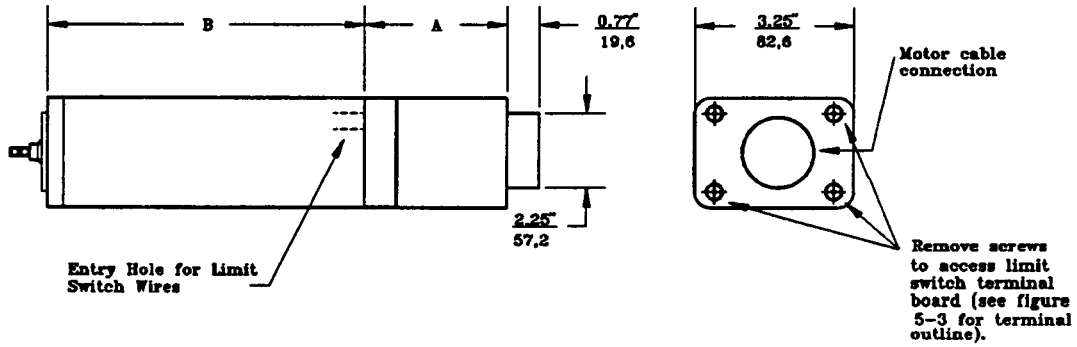

	A	B
1017LT	2.91" 73.9	3.30" 83.8
1035LT	2.91" 73.9	4.11" 104.4
1050LT	2.91" 73.9	4.91" 124.7

MSO1 - 1075LT, 1135LT Motors

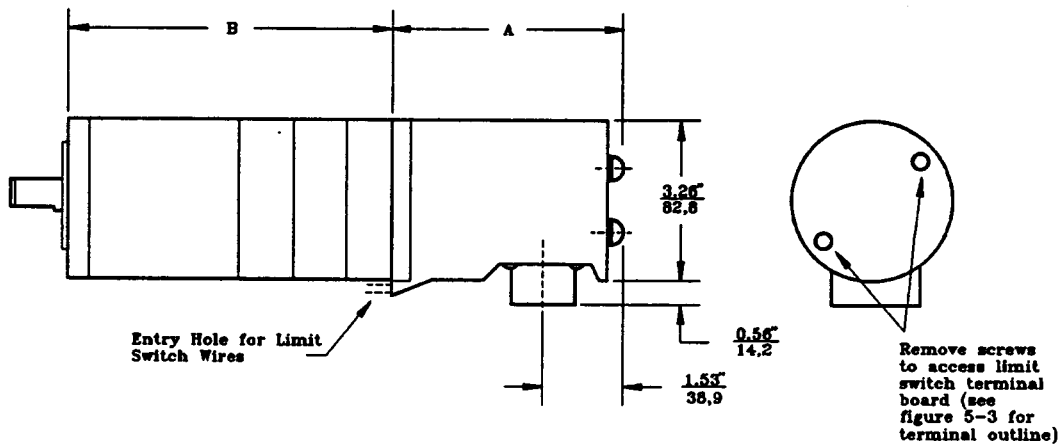

	A	B
1075LT	4.85" 123.2	4.85" 124.0
1135LT	4.85" 123.2	6.38" 162.1

Figure 5-1: Mechanical Dimensions for Unidex 11 DC Motors

MS01 - 1210LT, 1410LT Motors

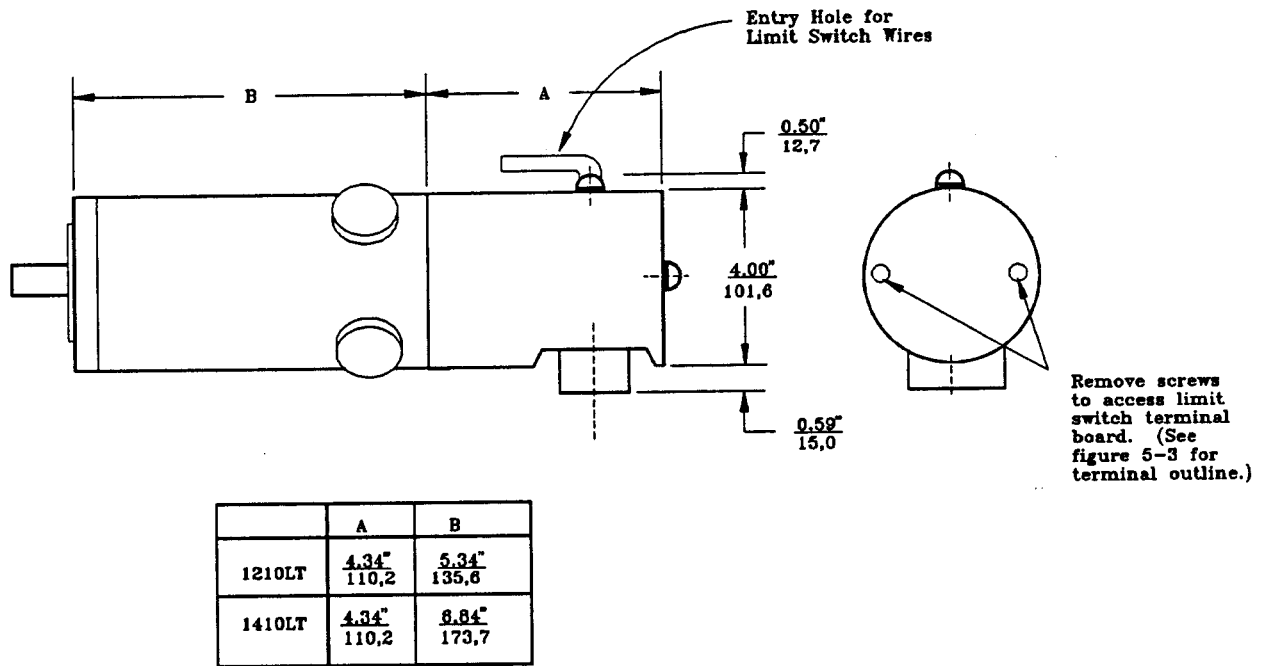
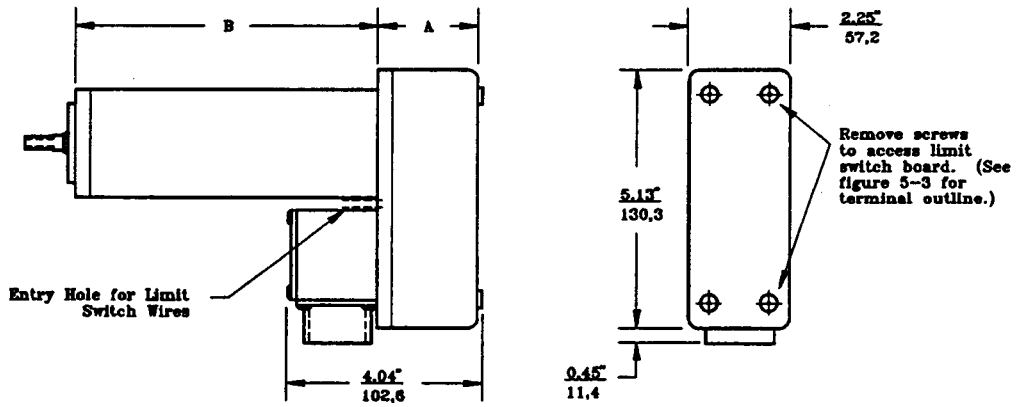

Figure 5-1: Continued

CHAPTER 5: STEPPING AND DC SERVO MOTORS

MSOF - 1017LT, 1035LT, 1050LT Motors



	A	B
1017LT	2.12" 53.8	3.30" 83.8
1035LT	2.12" 53.8	4.11" 104.4
1050LT	2.12" 53.8	4.91" 124.7

MSOF - 1075LT, 1135LT Motors

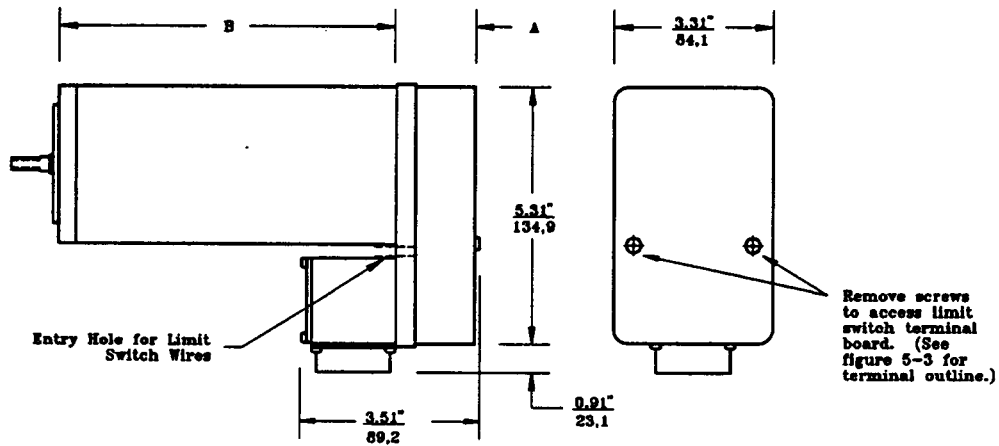

	A	B
1075LT	1.80" 40.6	4.88" 124.0
1135LT	1.80" 40.6	6.38" 162.1

Figure 5-1: Continued

DC2 - 1017LT, 1035LT, 1050LT Motors
 DC3 - 1075LT, 1135LT Motors

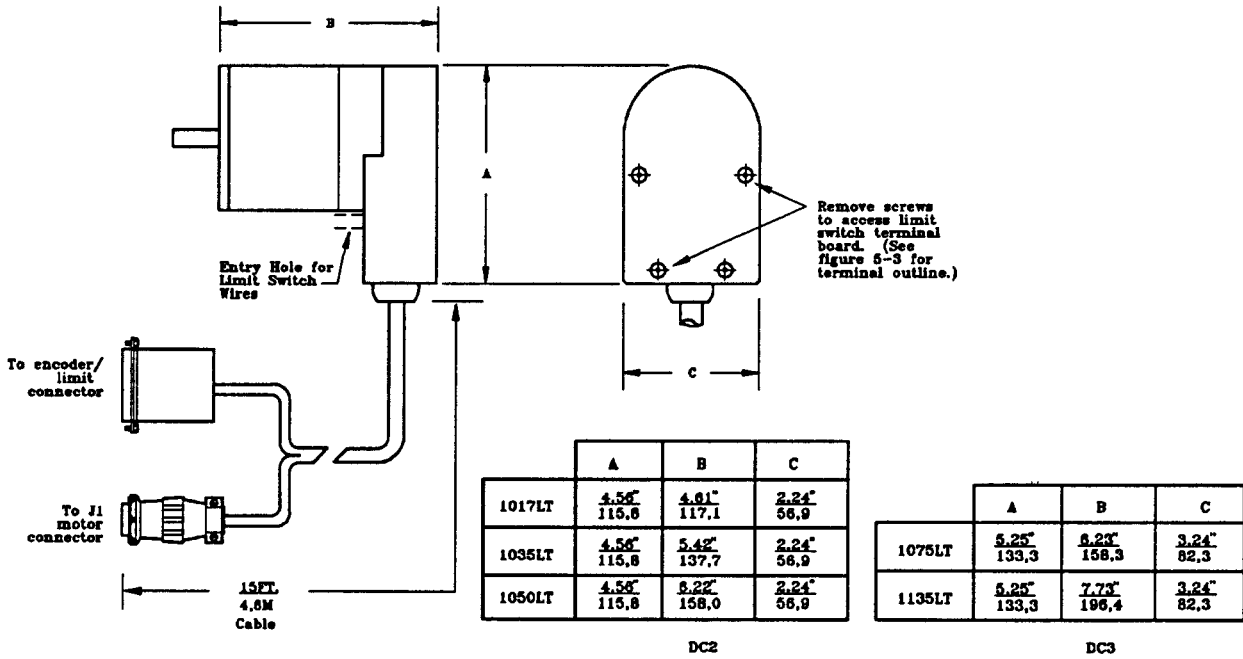

DC2E - 1017LT, 1035LT, 1050LT

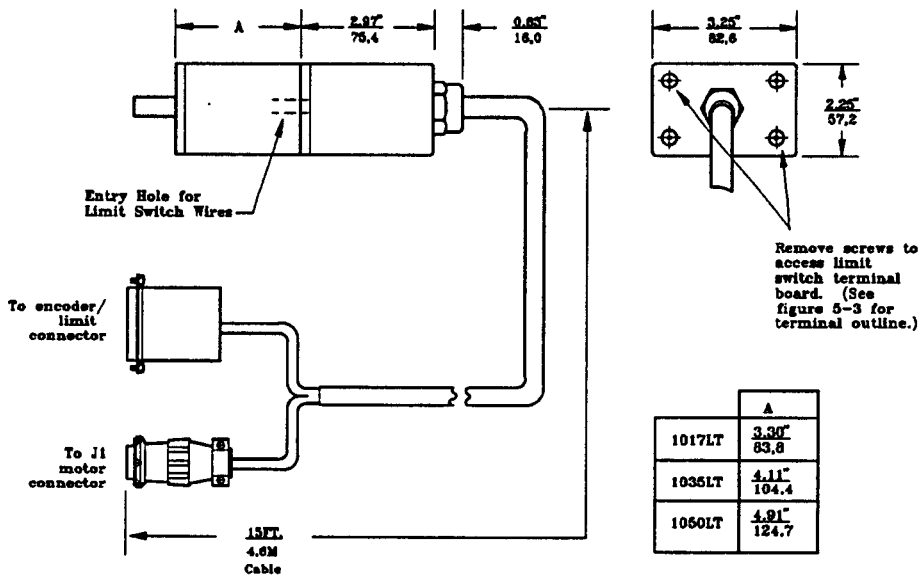

Figure 5-1: Continued

DC3E - 1075LT, 1135LT

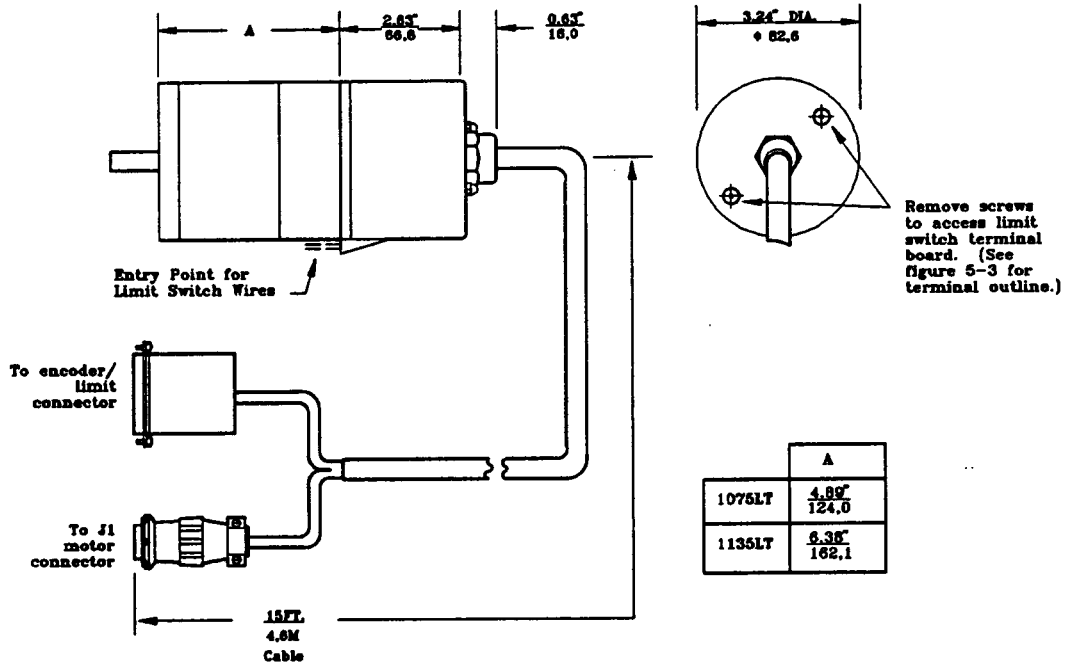
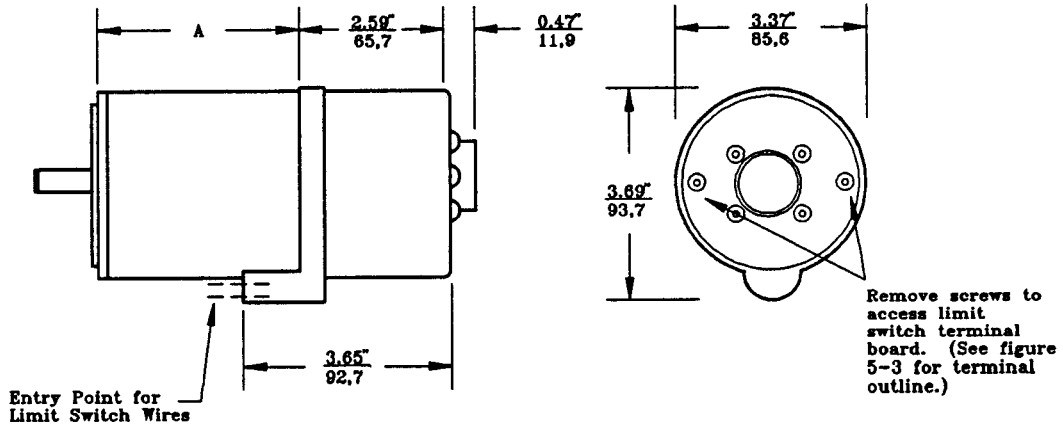

Figure 5-1: Continued

B3E-HM - 300SM, 310SM Motors



	A
300SM	5.06" 128,5
310SM	5.06" 128,5

B2E-HM - 50SM, 101SM Motors

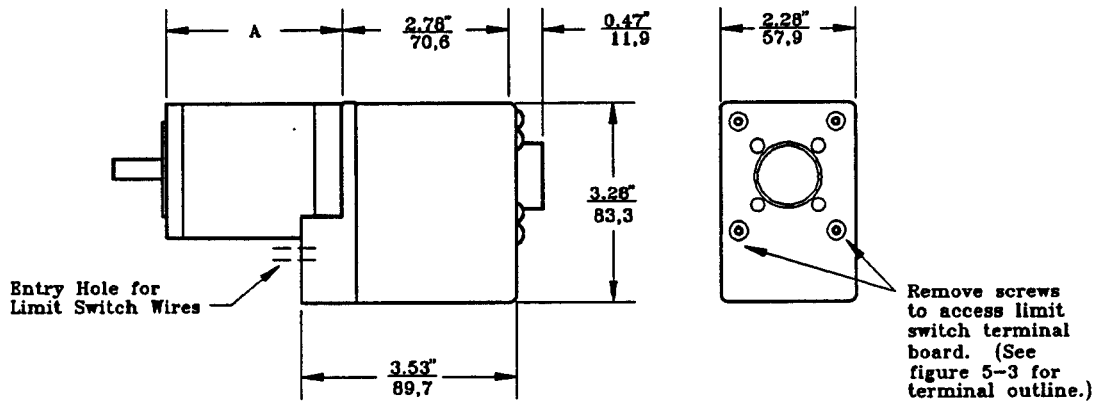

	A
50SM	2.00" 50,8
101SM	4.00" 101,6

Figure 5-2: Mechanical Dimensions for Unidex 11 Stepping Motors

C2E-HM - 50SM, 101SM Motors

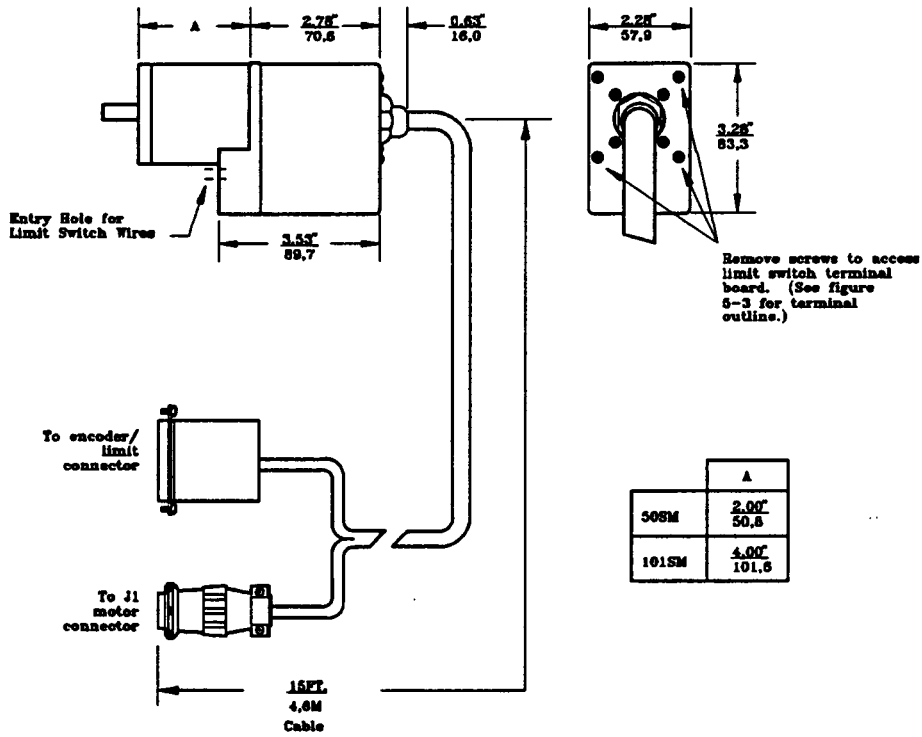

C3E-HM - 300SM, 310SM Motors

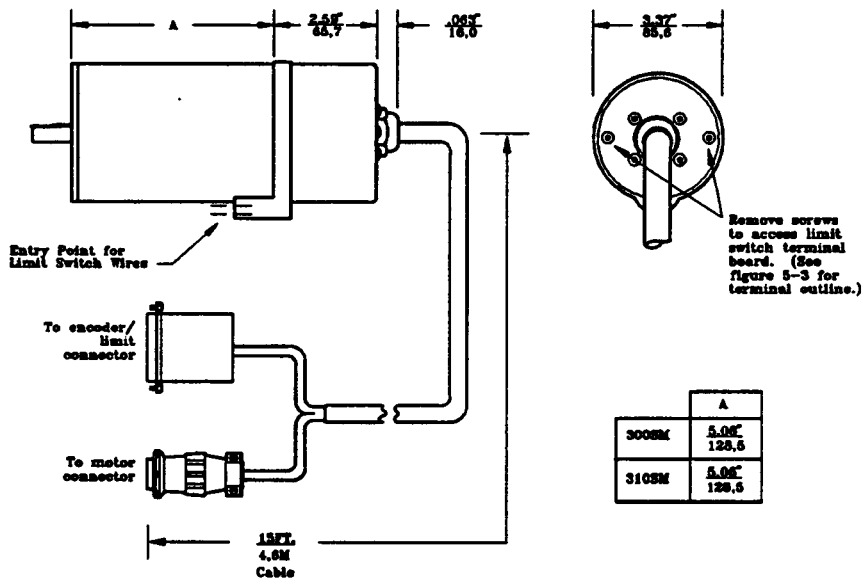
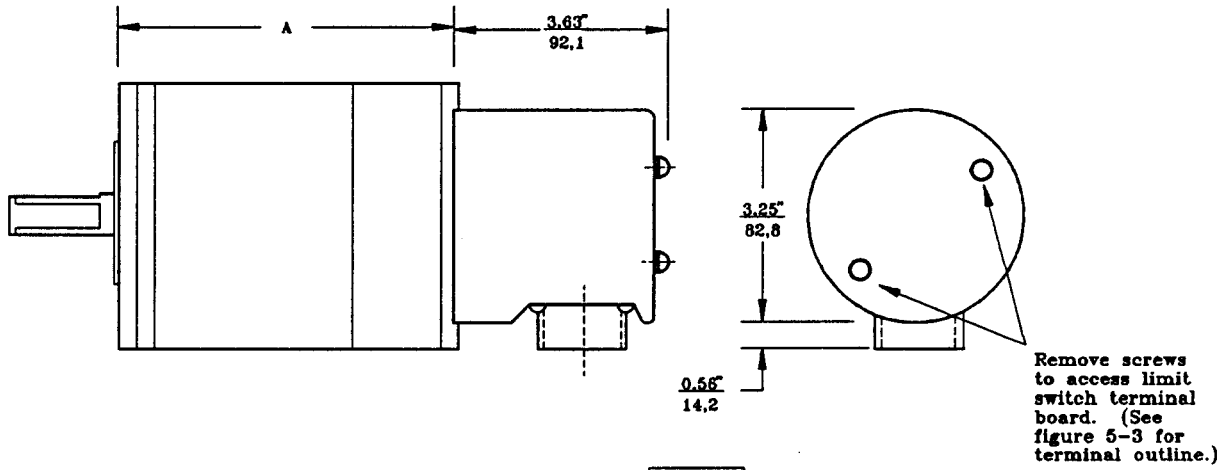

Figure 5-2: Continued

B4-HM - 510SM, 1010SM Motors



	A
510SM	5.44" 138,2
1010SM	7.56" 192,1

B2-HM, B2-HMK - 50SM, 101SM Motors
 B3-HM, B3-HMK - 300SM, 310SM Motors

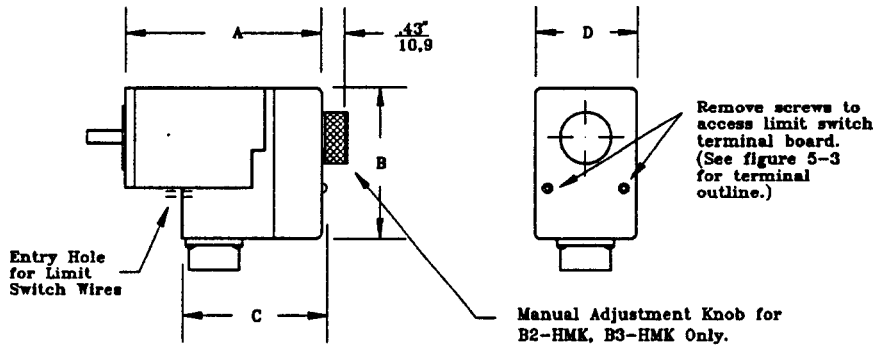

	A	B	C	D
50SM	3.32" 84,3	3.28" 83,3	3.04" 77,2	2.28" 57,9
101SM	5.32" 135,1	3.28" 83,3	3.04" 77,2	2.28" 57,9

	A	B	C	D
300SM	6.51" 165,3	4.12" 104,7	3.45" 87,6	3.40" 86,4
310SM	6.51" 165,3	4.12" 104,7	3.45" 87,6	3.40" 86,4

Figure 5-2: Continued

CHAPTER 5: STEPPING AND DC SERVO MOTORS

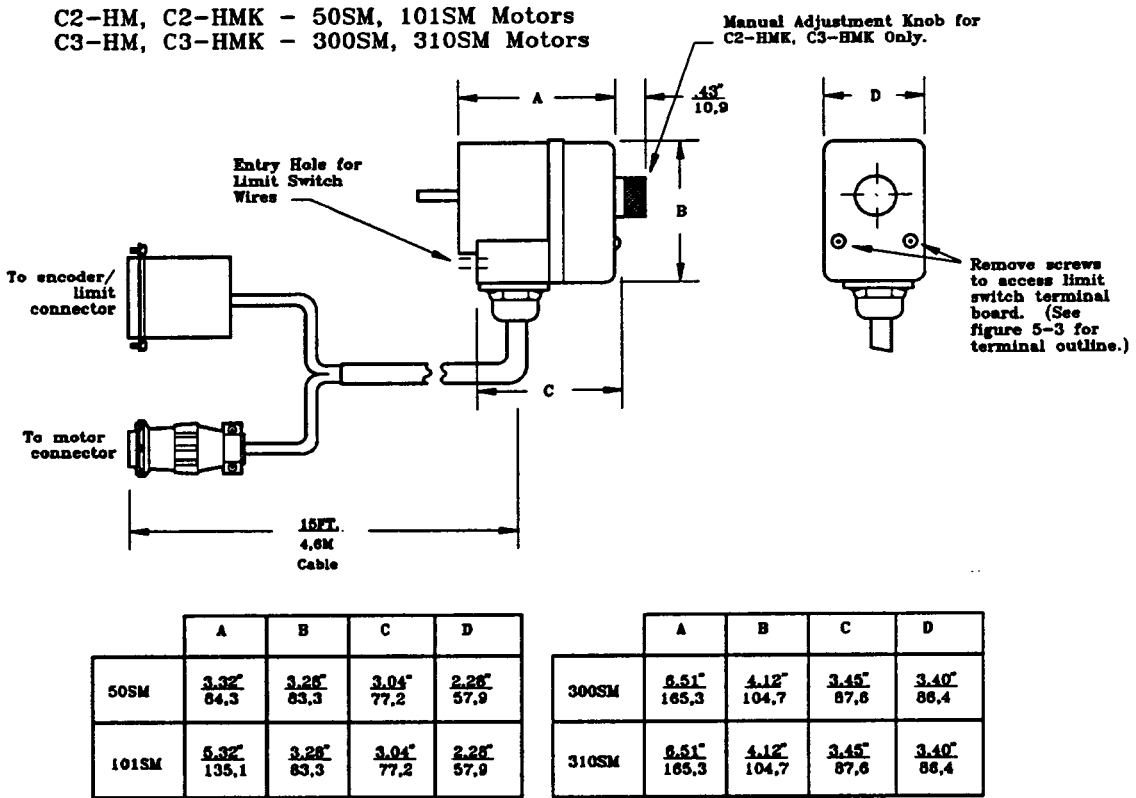
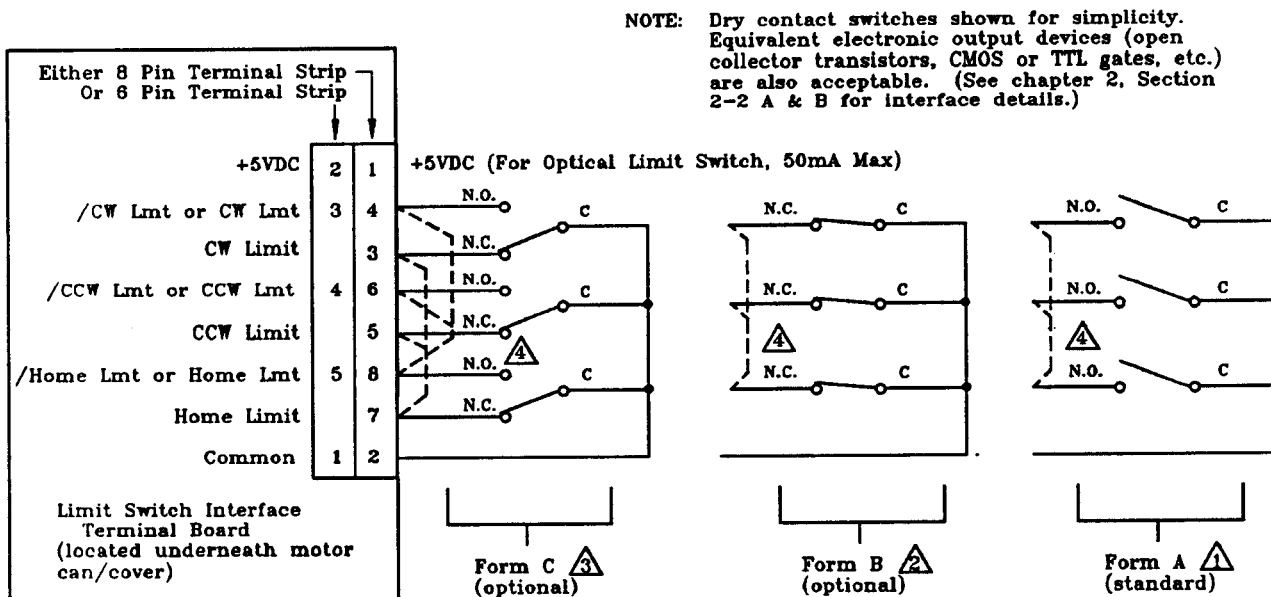

Figure 5-2: Continued



- [⚠] Form A, normally open (switch closes when in limit). Standard configuration unless otherwise specified. Reference chapter 2, section 2-2 A & B for interface details.
- [⚠] Form B, normally closed (switch opens when in limit). Optional configuration. Reference chapter 2, section 2-2 A & B for interface details. Reference chapter 4 for individual drive module specifications on necessary jumper configuration.
- [⚠] Form C (used with limit debounce latch). Optional configuration. If use is required, contact factory.
- [⚠] All Unidex 11 Controllers are configured to accept (require) home limit inputs. This input may come from an independent switch (cam option on rotary stages) or may be paralleled from the CCW (standard) or CW (optional) limit switches (on linear stages).

Figure 5-3: Limit Switch Terminal Board Definitions

CHAPTER 5: STEPPING AND DC SERVO MOTORS

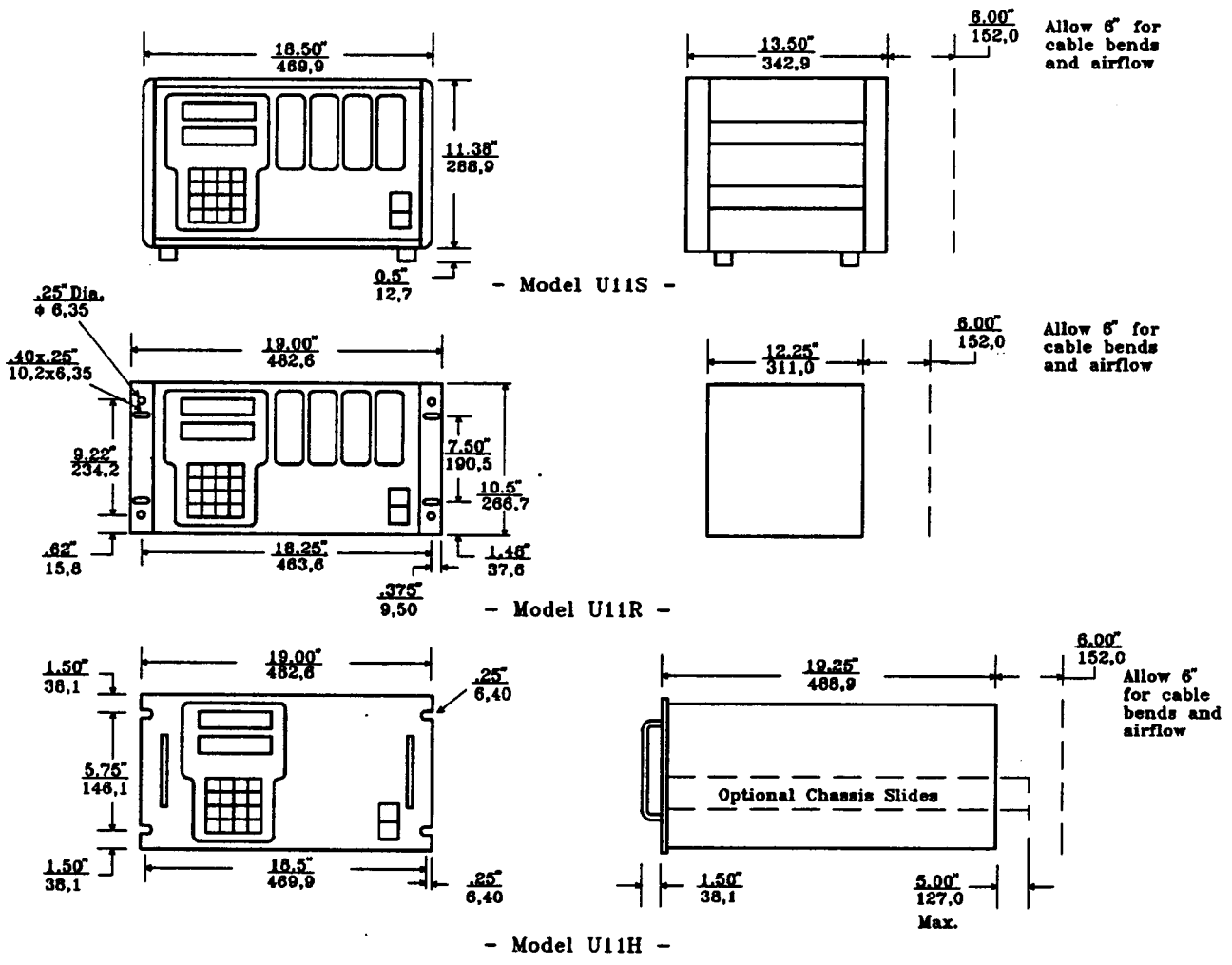
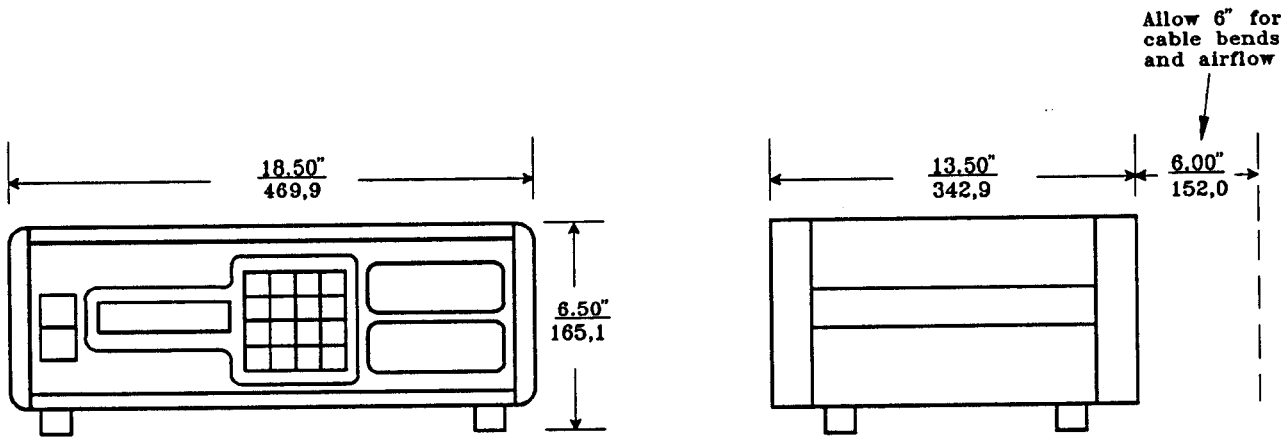

Figure 5-4: Dimensional Data for the Unidex 11 Family of Controllers



- Model U11M -

Figure 5-4: Continued

SERVICE AND REPAIR

If necessary, any on-site service should be performed by an experienced electronic technician, preferably one trained by Aerotech, Inc.

SHIPMENT

The procedure for shipping equipment back to Aerotech, which is described below, pertains to warranty as well as non-warranty repairs.

1. Before shipping any equipment back to Aerotech, the person making the return must call ahead for a "*Return Authorization Number*".
2. The equipment being returned must be encased in a proper cushioning material and enclosed in a cardboard box.

Call for a "Return Authorization Number" if it is necessary to ship any part to the factory.

Warning: Damage due to improper packaging voids warranty!

Aerotech Sales and Service offices are listed on the following pages. For service and information, contact the office servicing your area.

AEROTECH, INC. SALES OFFICES

World Headquarters AEROTECH, INC.

101 Zeta Drive
Pittsburgh, PA 15238

Phone (412) 963-7470
FAX (412) 963-7459
TWX (710) 795-3125

AEROTECH NORTHEAST

Executive Suite 120
270 Farmington Avenue
Farmington, CT 06032
Phone (203) 673-3330
or (203) 673-2503
FAX (203) 674-1536

MA, CT, VT, ME, RI, NH, eastern
NY

AEROTECH CENTRAL-WEST

26791 Lake Vue Drive #8
Perrysburg, OH 43551
Phone (419) 874-3990
FAX (419) 874-4280
MI, IN, KY, western OH

AEROTECH MIDWEST

PO Box 625
Dundee, IL 60118
Phone (312) 428-5440
FAX (312) 428-5471
IL, MO, KS, WI, MN, ND, SD, IA,
NE

AEROTECH, CENTRAL- EAST

856 Cottonwood Drive
Monroeville, PA 15146

Phone (412) 373-4160
FAX (412) 373-4163
WV, western PA, western NY,
eastern OH

AEROTECH SOUTHWEST

6001 Village Glen Drive
#3101
Dallas, TX 75206
Phone (214) 987-4556
FAX (214) 987-4706
TX, OK, LA, AR, CO, UT, MT,
WY, ID, NM

AEROTECH NORTHWEST

444 Castro Street
Suite 400
Mountain View, CA 94041
Phone (415) 967-4996
FAX (415) 967-4998
northern CA, OR, WA, NV

AEROTECH WEST

Suite 217
7002 Moody Street
La Palma, CA 90623
Phone (213) 860-7470
FAX (213) 860-4639
AZ, southern CA

AEROTECH MID-ATLANTIC

521 Kingwood Road
King of Prussia, PA 19406
Phone (215) 265-6446
FAX (215) 265-3566
MD, DC, DE, NJ, northern
VA, eastern PA

AEROTECH SOUTH ATLANTIC

8804 Lomas Court
Raleigh, NC 27615
Phone (919) 848-1965
FAX (919) 848-3393
NC, TN, southern VA, AL, FL,
GA, SC, MS

INTERNATIONAL SALES OFFICES

AEROTECH LTD.

3 Jupiter House, Calleva Park
Aldermaston
Berkshire RG7 4QW England
Phone (07356) 77274
TLX 847228
FAX (07356) 5022

AEROTECH GMBH

Neumeyerstrasse 90
8500 Nuernberg 10
West Germany
Phone (0911) 521031
TLX 622474
FAX (0911) 521235

AEROTECH AUSTRALASIA

224 Carr Street
Suite 7
Leederville 6007
Western Australia
Phone (619) 328-2540
FAX (619) 227-6670

INTERNATIONAL REPRESENTATIVES

BRASITEC

Rue Americo Brasiliense, 2069
Chacara Santo Antonio
Cep 04715 - Sao Paulo - SP
Brazil
Phone (5511) 523 4044
TLX 1130691 BRTC

Y. BEN MOSHE

PO Box 18125
Tel Aviv 61181
Israel
Phone (9723) 7515007
or (9723) 7513268
TLX 342436 BMS IL
FAX (9723) 727319

SIMCO

208, First Floor
Ajmeri Gate
New Delhi 110 006 India
Phone 652986
TLX 031-62176 HARS IN
FAX (9111) 510697

OPTIKON CORPORATION LTD.

410 Conestogo Road
Waterloo, Ontario
Canada, N2L 4E2
Phone 519-885-2551
FAX 519-885-4712

DONG DO TRADING CO. LTD.

Rm 903, Kwang Sung Bldg.
831-47 Youksamdong
Kangnam-Ku, Seoul, Korea
Phone (822) 556-2292
FAX (822) 556-2902
TLX 29734 DONG DO

TOKYO INSTRUMENTS INC.

Asahi-Seimei Bldg.
6-8-10 Nishikasai
Edogawa-Ku
Tokyo 134 Japan
Phone (813) 686-4711
FAX (813) 686 0831

HISCO (MALAYSIA) SDN.BHD.

1 Lorong SS13/6A
Subang Jaya Indust. Estate
47500 Petaling Jaya
Selanger, Malaysia
Phone (603) 733-4236
FAX (603) 733-6281
TLX 36226 HISCO MA

Index

A

Auxiliary control, 23
Auxiliary control connections, 19

C

Connector
 IEEE-488, 30
 Input/Output, 24
 Joystick interface, 28
 Opto-interface, 26
 RS-232, 30
Connector specifications, 11, 16, 17, 20
Connectors
 Power, 37
Control board, 123
Circuit description, 123
Control connections, 10
 Auxiliary, 19, 21

D

D3001/D1401
 Auxiliary control, 58
 Circuit description, 53
 Definition of +/- direction, 57
 Home clock oscillator, 60
 Home reference, 54
 Limit switch polarity, 57
 Marker buffer circuit, 56
 Personality module, 59
 Selecting stepping motor resolution, 58
 Slew clock oscillator, 60
 Stepping drives, 53
DC servo drive, 53
DC servo motors, 127
Digital I/O port connector, 31
DM1501 stepping drive, 64

DM1501,DM4001,DM4005
 Auxiliary control option, 69
 Circuit description, 64
 Current levels, 73
 Definition of +/- direction, 68
 Home clock oscillator, 72
 Home reference, 65
 Limit switch polarity, 68
 Marker buffer circuit, 67
 Personality module, 71
 Slew clock oscillator, 72
 Stepping motor resolution, 69

DM4001 stepping drive, 64

DM4005 stepping drive, 64

DM6006

 Auxiliary control options, 82
 Circuit description, 77
 Current level adjustment, 85
 Definition of +/- direction, 81
 Home clock oscillator, 85
 Home reference, 78
 Limit switch polarity, 81
 Marker buffer circuit, 80
 Personality module, 84
 Selecting stepping motor resolution, 82
 Slew clock oscillator, 84

DM6006 Stepping drive module, 77

DMV8008 and DMV16008 drive modules, 89

DMV8008,DMV16008

 Circuit description, 89
 Definition of +/- direction, 93
 Home clock oscillator adjustment, 97
 Home reference, 90
 Limit switch polarity, 93
 Lo/hi current level adjustment, 97
 Marker buffer circuit, 92
 Personality module RCN1, 96
 Stepping motor resolution, 94

DSL8020

- Circuit description, 101
- Encoder multiplication parameters, 109
- Home reference, 105
- Limit switch polarity, 109
- Marker input circuit, 108
- Motor load fuse ratings, 104
- Motor/encoder/tach phasing, 104
- Operation, 101
- Optional tachometer, 104
- Position and Velocity adjustment, 113
- Potentiometer and test points, 110

DSL8020 drive module, 101

E

Encoder, 11

H

- Hardware specifications, 127
- High speed binary interface, 31

I

- IEEE-488 connector, 30
- Input/output interface connector, 24
- Introduction, 1

J

Joystick interface connector, 28

L

Limit switch, 11

M

- Manual description, 2
- Marker, 11

O

Opto-interface connector, 26

P

- Power connections, 37
- Power supply board, 120
- Power supply board circuit description, 120

R

- Rear panel connections, 5
- RS-232 connector, 30

S

- Serial output interface (SEO), 32
- Slew clock oscillator adjustment, 84
- Stepping drive, 53
- Stepping servo motors, 127

T

TDT thumbwheel connector, 31

U

Unidex 11 internal structure, 43



Warranty and Field Service Policy

Aerotech, Inc. warrants its products to be free from defects caused by faulty materials or poor workmanship for a minimum period of one year from date of shipment from Aerotech. Aerotech's liability is limited to replacing, repairing or issuing credit, at its option, for any products which are returned by the original purchaser during the warranty period. Aerotech makes no warranty that its products are fit for the use or purpose to which they may be put by the buyer, whether or not such use or purpose has been disclosed to Aerotech in specifications or drawings previously or subsequently provided, or whether or not Aerotech's products are specifically designed and/or manufactured for buyer's use or purpose. Aerotech's liability on any claim for loss or damage arising out of the sale, resale or use of any of its products shall in no event exceed the selling price of the unit.

Laser Product Warranty

Aerotech, Inc. warrants its laser products to the original purchaser for a minimum period of one year from date of shipment. This warranty covers defects in workmanship and material and is voided for all laser power supplies, plasma tubes and laser systems subject to electrical or physical abuse, tampering (such as opening the housing or removal of the serial tag) or improper operation as determined by Aerotech. This warranty is also voided for failure to comply with Aerotech's return procedures.

Return Products Procedure

Claims for shipment damage (evident or concealed) must be filed with the carrier by the buyer. Aerotech must be notified within (30) days of shipment of incorrect materials. No product may be returned, whether in warranty or out of warranty, without first obtaining approval from Aerotech. No credit will be given nor repairs made for products returned without such approval. Any returned product(s) must be accompanied by a return authorization number. The return authorization number may be obtained by calling an Aerotech service center. Products must be returned, prepaid, to an Aerotech service center (no C.O.D. or Collect Freight accepted). The status of any product returned later than (30) days after the issuance of a return authorization number will be subject to review.

Returned Product Warranty Determination

After Aerotech's examination, warranty or out-of-warranty status will be determined. If upon Aerotech's examination a warrantied defect exists, then the product(s) will be repaired at no charge and shipped, prepaid, back to the buyer. If the buyer desires an air freight return, the product(s) will be shipped collect. Warranty repairs do not extend the original warranty period.

Returned Product Non-Warranty Determination

After Aerotech's examination, the buyer shall be notified of the repair cost. At such time the buyer must issue a valid purchase order to cover the cost of the repair and freight, or authorize the product(s) to be shipped back as is, at the buyer's expense. Failure to obtain a purchase order number or approval within (30) days of notification will result in the product(s) being returned as is, at the buyer's expense. Repair work is warranted for (90) days from date of shipment. Replacement components are warranted for one year from date of shipment.

Rush Service

At times, the buyer may desire to expedite a repair. Regardless of warranty or out-of-warranty status, the buyer must issue a valid purchase order to cover the added rush service cost. Rush service is subject to Aerotech's approval.

On-Site Warranty Repair

If an Aerotech product cannot be made functional by telephone assistance or by sending and having the customer install replacement parts, and cannot be returned to the Aerotech service center for repair, and if Aerotech determines the problem could be warranty-related, then the following policy applies.

Aerotech will provide an on-site field service representative in a reasonable amount of time, provided that the customer issues a valid purchase order to Aerotech covering all transportation and subsistence costs. For warranty field repairs, the customer will not be charged for the cost of labor and material. If service is rendered at times other than normal work periods, then special service rates apply.

If during the on-site repair it is determined the problem is not warranty related, then the terms and conditions stated in the following "On-Site Non-Warranty Repair" section apply.

On-Site Non-Warranty Repair

If an Aerotech product cannot be made functional by telephone assistance or purchased replacement parts, and cannot be returned to the Aerotech service center for repair, then the following field service policy applies.

Aerotech will provide an on-site field service representative in a reasonable amount of time, provided that the customer issues a valid purchase order to Aerotech covering all transportation and subsistence costs and the prevailing labor cost, including travel time, necessary to complete the repair.

AEROTECH, Inc., 101 Zeta Drive, Pittsburgh, Pennsylvania 15238

Phone (412) 963-7470 • TWX 710-795-3125 • FAX (412) 963-7459