

Ndrive HL User's Manual

P/N: EDU176 (Revision: 1.08b)



Dedicated to the Science of Motion
Aerotech, Inc.
101 Zeta Drive, Pittsburgh, PA, 15238
Phone: 412-963-7470 Fax: 412-963-7459
www.aerotech.com



Product Registration

Register online at: <http://www.aerotech.com/prodreg.cfm>

Technical Support

United States Headquarters:

Phone: (412) 967-6440

Fax: (412) 967-6870

Email: service@aerotech.com

United Kingdom:

Phone: +44 118 940 9400

Fax: +44 118 940 9401

Email: service@aerotech.co.uk

Germany:

Phone: +49 911 967 9370

Fax: +49 911 967 93720

Email: service@aerotechgmbh.de

Revision History

1.00	June 20, 2003
1.01	February 9, 2004
1.02	May 27, 2004
1.03	July 26, 2004
1.04	September 1, 2004
1.05	September 23, 2004
1.06	November 22, 2005
1.07	January 4, 2006
1.08b	October 31, 2007

Product names mentioned herein are used for identification purposes only and may be trademarks of their respective companies.

TABLE OF CONTENTS

CHAPTER 1: INTRODUCTION	1-1
1.1. Feature Summary	1-2
1.2. Connection Overview	1-3
1.3. Ndrive HL Block Diagram.....	1-4
1.4. Ordering Information	1-5
1.5. Electrical Specifications	1-6
1.6. Mechanical Specifications.....	1-9
1.7. Environmental Specifications.....	1-10
CHAPTER 2: INSTALLATION and CONFIGURATION	2-1
2.1. Safety Procedures and Warnings	2-1
2.2. Power Connections.....	2-2
2.2.1. Control Power Connections (-AUXPWR)	2-2
2.2.2. Motor Power Connections	2-3
2.2.3. Motor Connections (TB101).....	2-4
2.2.4. I/O and Signal Wiring Requirements	2-4
2.3. Emergency Stop Sense Input (TB201).....	2-5
2.3.1. Typical ESTOP Interface	2-6
2.4. Motor and Feedback Connections.....	2-7
2.4.1. DC Brush Motor in Torque Mode Configuration	2-7
2.4.2. DC Brush Motor with Tachometer Feedback Configuration.....	2-8
2.4.3. Brushless Motor Configuration	2-9
2.4.4. Stepper Motor Configuration.....	2-14
2.5. Encoder Feedback Connections.....	2-15
2.5.1. Encoder Phasing.....	2-16
2.6. End of Travel (EOT) Limit Input Connections	2-17
2.6.1. End of Travel (EOT) Limit Phasing	2-17
2.7. Communication Channel Settings	2-18
2.8. Connecting Multiple Ndrive HLs	2-19
2.9. PC Configuration and Operation Information.....	2-20
CHAPTER 3: TECHNICAL DETAILS.....	3-1
3.1. Auxiliary I/O Connector (J205).....	3-1
3.1.1. Secondary Encoder Channel (J205).....	3-3
3.1.2. User Outputs 8-11 (J205)	3-4
3.1.3. User Inputs 8-11 (J205)	3-5
3.1.4. High Speed User Inputs 12-13 (J205)	3-6
3.1.5. Analog Input 0 (J205).....	3-6
3.1.6. Analog Output 0 (J205).....	3-6
3.2. Position Synchronized Output (PSO) / Laser Firing	3-7
3.2.1. Single Axis Laser Firing	3-11
3.3. Motor Feedback (J207).....	3-12
3.3.1. End of Travel Limit Inputs	3-13
3.3.2. Hall-Effect and Thermistor Inputs	3-14
3.3.3. Brake Output.....	3-15
3.3.4. Encoder Interface.....	3-15
3.4. RS-232 / RS-422 Port (J206).....	3-20
3.5. FireWire Bus (J201, J202, J203)	3-22

- 3.6. Voltage-to-Current Mode Operation 3-23
 - 3.6.1. Parameter Setup and Hardware Configuration 3-24
 - 3.6.2. Saving Parameters to the Flash Memory on the Drive 3-24
 - 3.6.3. Operation 3-25
 - 3.6.4. Faults 3-25
- CHAPTER 4: OPTIONS 4-1**
 - 4.1. –IOPSO and –IOPSOH Option Boards 4-1
 - 4.1.1. Brake Configuration Jumpers 4-2
 - 4.1.2. Analog Outputs (TB301) 4-3
 - 4.1.3. Brake / Relay (TB301) 4-4
 - 4.1.4. Analog Inputs (TB302) 4-9
 - 4.1.5. User Power Connector (TB303) 4-10
 - 4.1.6. Opto-Isolated Outputs (TB304) 4-10
 - 4.1.7. Opto-Isolated Inputs (TB305) 4-12
 - 4.1.8. PSO / Absolute Encoder Interface (J301) 4-14
 - 4.1.9. SSI Net (2 channel) (J302, J303) 4-17
 - 4.2. –DUALPSO and –TRIPLEPSO Laser Firing Options 4-19
 - 4.2.1. PSO Tracking Rate Configuration 4-20
 - 4.3. –ENET (Ethernet) Option J204 4-22
 - 4.4. –RDP Resolver Input 4-23
 - 4.4.1. Resolver/Inductosyn Setup 4-24
- CHAPTER 5: ACCESSORIES 5-1**
 - 5.1. Standard Interconnection Cables 5-1
 - 5.2. Joystick Interface 5-5
 - 5.3. Handwheel Interface 5-9
- CHAPTER 6: TROUBLESHOOTING 6-1**
 - 6.1. Problems, Causes, and Solutions 6-1
 - 6.2. Ndrive HL Control Board Test Points 6-2
 - 6.3. Ndrive HL Control Board Assembly 6-3
 - 6.4. Ndrive HL Motor Power Board Assembly 6-5
 - 6.5. Ndrive HL Power Supply Board Assembly 6-7
 - 6.6. LED Indicators 6-9
 - 6.7. JTAG Programming Connector 6-10
 - 6.8. Fuse / Battery Replacement 6-11
 - 6.9. Preventative Maintenance 6-12
 - 6.9.1. Cleaning 6-12
- APPENDIX A: GLOSSARY of TERMS A-1**
- APPENDIX B: WARRANTY and FIELD SERVICE B-1**
- APPENDIX C: MANUAL UPDATES C-1**
 - B.1. Current Changes C-1
 - B.2. Archive of Changes C-2
- INDEX Index-1**
- READER’S COMMENTS Comment-1**



LIST OF FIGURES

Figure 1-1.	Ndrive HL Networked Digital Drive	1-1
Figure 1-2.	Ndrive HL Hardware	1-3
Figure 1-3.	Ndrive HL Functional Diagram.....	1-4
Figure 1-4.	Ndrive HL Dimensions	1-9
Figure 2-1.	-AUXPWR Option	2-2
Figure 2-2.	Motor Power Connections.....	2-3
Figure 2-3.	ESTOP Sense Input (TB201).....	2-5
Figure 2-4.	Typical Emergency Stop Circuit.....	2-6
Figure 2-5.	DC Brush Motor in Torque Mode Configuration	2-7
Figure 2-6.	DC Brush Motor Wiring with Tachometer	2-8
Figure 2-7.	Brushless Motor Configuration	2-9
Figure 2-8.	Hall-Effect Feedback Connections	2-11
Figure 2-9.	Hall-Effect Feedback Inputs in the Nstat Utility.....	2-11
Figure 2-10.	Motor Phasing	2-13
Figure 2-11.	Stepper Motor Configuration.....	2-14
Figure 2-12.	Encoder Feedback Connections.....	2-15
Figure 2-13.	Encoder Phasing Reference Diagram	2-16
Figure 2-14.	Encoder and Hall signals in the Nstat.exe Utility Program	2-16
Figure 2-15.	End of Travel Limit input Connections	2-17
Figure 2-16.	Limit Inputs in the Nstat Utility.....	2-17
Figure 2-17.	Recommended Star Daisy Chain Configuration.....	2-19
Figure 2-18.	FireWire Daisy Chain	2-20
Figure 3-1.	Secondary Encoder Channel (J205).....	3-3
Figure 3-2.	User Outputs (J205).....	3-4
Figure 3-3.	All User Inputs 8-13 (J205)	3-5
Figure 3-4.	Advanced 1 - 3 Axis Firing	3-9
Figure 3-5.	Data Capture/Data Update Modes	3-10
Figure 3-6.	PSO Diagram – Basic Single Axis Firing	3-11
Figure 3-7.	End of Travel Limit Inputs	3-13
Figure 3-8.	Hall-Effect and Thermistor Inputs (J207).....	3-14
Figure 3-9.	Line Driver Encoder Interface – Standard (J207)	3-16
Figure 3-10.	Optional MXH Analog Encoder Interface (J207)	3-19
Figure 3-11.	RS-232/RS-422 Connector (J206).....	3-21
Figure 3-12.	Normal Operation.....	3-23
Figure 3-13.	Stand-Alone Configuration.....	3-23
Figure 4-1.	–IOPSO Option Board Location.....	4-1
Figure 4-2.	–IOPSO Option Board (690D1579 Rev. A)	4-1
Figure 4-3.	–IOPSOH Option Board (690D1623 Rev. 0)	4-2
Figure 4-4.	Analog Output Connector (TB301)	4-3
Figure 4-5.	Brake Connected to TB301.....	4-5
Figure 4-6.	Brake Connected to J207	4-6
Figure 4-7.	Diode Suppression for DC Brake Systems.....	4-7
Figure 4-8.	RC Suppression for DC Brake Systems	4-8
Figure 4-9.	Optional Analog Input Connector (TB302).....	4-9
Figure 4-10.	Connecting Outputs in Current Sinking Mode	4-11

Figure 4-11.	Connecting Outputs in Current Sourcing Mode.....	4-11
Figure 4-12.	Inputs Connected in Current Sourcing Mode	4-13
Figure 4-13.	Inputs Connected in Current Sinking Mode.....	4-13
Figure 4-14.	Absolute Encoder Interface (J301)	4-15
Figure 4-15.	PSO Interface (J301 and TB303)	4-16
Figure 4-16.	(RS-485) Absolute Encoder Interface (J301)	4-16
Figure 4-17.	J301/J302/J303.....	4-18
Figure 4-18.	Two / Three Axis Laser Firing Interconnection	4-19
Figure 4-19.	PSO Tracking Rate Block Diagram	4-20
Figure 4-20.	Ethernet Interface (J204)	4-22
Figure 4-21.	Resolver Option Assembly (690D1599 Rev. 0).....	4-24
Figure 4-22.	Analog Output Connector (TB301)	4-25
Figure 4-23.	Resolver Located at Maximum of SIN Signal	4-27
Figure 4-24.	Rotating the Resolver (to see a circle)	4-28
Figure 4-25.	Optimized Resolver Feedback Configuration	4-29
Figure 5-1.	Joystick Interface	5-5
Figure 5-2.	Single Axis Joystick Interface to J205 of the Ndrive HL	5-6
Figure 5-3.	Single Axis Joystick Interconnect to J205 of the Ndrive HL.....	5-7
Figure 5-4.	Two-Axis Joystick Interface to the I/O on the -IOPSO Option.....	5-7
Figure 5-5.	Two-Axis Joystick Connection to the I/O on the -IOPSO Option.....	5-8
Figure 5-6.	Handwheel Interconnection to J205 of the Ndrive HL	5-9
Figure 5-7.	Handwheel with Flying Leads (no connector).....	5-10
Figure 5-8.	BBA32 Interface used to connect a Handwheel with flying leads (no connector).....	5-10
Figure 6-1.	Ndrive HL Control Board Assembly (690D1577 Rev. A).....	6-3
Figure 6-2.	Ndrive HL Motor Power Board, (690D1589 Rev 0)	6-5
Figure 6-3.	Ndrive HL Power Supply Board, (690D1588 Rev -)	6-7



LIST OF TABLES

Table 1-1.	Ndrive HL Models and Voltage Configurations.....	1-5
Table 1-2.	Electrical Specifications	1-6
Table 1-3.	Ndrive HL Series Amplifier Current Limitations	1-8
Table 2-1.	Optional Aux Supply AC Input (for external E-Stop).....	2-2
Table 2-2.	Main Supply AC Power Input Connections.....	2-3
Table 2-3.	TB101 Motor Power Output Connections	2-4
Table 2-4.	Electrical Noise Suppression Devices	2-5
Table 2-5.	Ndrive HL Switch Settings (S2).....	2-18
Table 2-6.	FireWire Card and Cable Part Numbers.....	2-19
Table 3-1.	Auxiliary I/O Connector Pin Assignment (J205)	3-1
Table 3-2.	Auxiliary I/O Mating Connector (J205).....	3-2
Table 3-3.	Auxiliary Encoder Pin Assignment on Connector (J205).....	3-3
Table 3-4.	User Outputs Pin Assignment on Connector (J205).....	3-4
Table 3-5.	User Inputs Pin Assignment on Connector (J205)	3-5
Table 3-6.	High Speed User Inputs Pin Assignment on Connector J205	3-6
Table 3-7.	Auxiliary I/O Connector Pin Assignment (J205)	3-6
Table 3-8.	Auxiliary I/O Connector Pin Assignment (J205)	3-6
Table 3-9.	PSO Encoder Signal Sources and Pre-Scaling Methods	3-7
Table 3-10.	PSO Output Sources	3-7
Table 3-11.	Motor Feedback Connector Pin Assignment (J207).....	3-12
Table 3-12.	Motor Feedback Mating Connector (J207).....	3-12
Table 3-13.	End of Travel Limit Inputs Pin Assignment on Connector J207	3-13
Table 3-14.	Hall-Effect Inputs Pin Assignment on Connector J207	3-14
Table 3-15.	Brake Output Pin Assignment on Connector J207	3-15
Table 3-16.	Motor Feedback Connector Pin Assignment (J207).....	3-15
Table 3-17.	MXH Option Specifications	3-18
Table 3-18.	J206 RS-232 / RS-422 Connector Pin Assignment.....	3-20
Table 3-19.	RS-232 / RS-422 Port Mating Connector (J206).....	3-20
Table 3-20.	J201, J202, J203 FireWire Connector Pin Assignment.....	3-22
Table 4-1.	–IOPSO Option Board Jumpers	4-1
Table 4-2.	–IOPSOH Output Device Numbers	4-2
Table 4-3.	Analog Output Connector Pin Assignment (TB301).....	4-3
Table 4-4.	Voltage and Current Specifications (TB301)	4-4
Table 4-5.	Brake / Relay Connector Pin Assignment (TB301)	4-5
Table 4-6.	Brake / Relay Connector Pin Assignment (J207)	4-5
Table 4-7.	Optional Analog Input Connector Pin Assignment (TB302)	4-9
Table 4-8.	User Power Connector Pin Assignment (TB303)	4-10
Table 4-9.	Opto-Isolated Output Connector Pin Assignment (TB304)	4-10
Table 4-10.	Output Specifications (TB304).....	4-11
Table 4-11.	Opto-Isolated Input Connector Pin Assignment (TB305)	4-12

Table 4-12.	PSO/Absolute Encoder Interface Connector Pin Assignment (J301).....	4-14
Table 4-13.	PSO / Absolute Encoder Mating Connector (J301).....	4-14
Table 4-14.	Laser Output Opto-Isolator Specifications.....	4-15
Table 4-15.	J302, J303 2-Channel SSI Net Connector Pin Assignment	4-17
Table 4-16.	SSI Net Cable Part Numbers.....	4-20
Table 4-17.	Ethernet Connector Pin Assignment (J204).....	4-22
Table 4-18.	NConnect I/O Cable part Numbers.....	4-22
Table 4-19.	Resolver Connector Pin Assignment (J1, J2).....	4-23
Table 4-20.	Resolver Mating Connector (15-Pin Male D-Style)	4-23
Table 4-21.	Resolver Jumper Configuration	4-23
Table 4-22.	Resolver Test Points.....	4-24
Table 4-23.	External Power Pin Assignment (J403).....	4-24
Table 5-1.	Standard Interconnection Cables	5-1
Table 5-2.	Combined Motor & Feedback Cables.....	5-2
Table 5-3.	Individual Motor Cables	5-3
Table 5-4.	Individual Feedback Cables.....	5-4
Table 6-1.	Amplifier Faults, Causes, and Solutions.....	6-1
Table 6-2.	Ndrive HL Control Board Test Point	6-2
Table 6-3.	Ndrive HL Control Board Jumper Selections.....	6-4
Table 6-4.	Ndrive HL Motor Power Board Jumper Selections.....	6-6
Table 6-5.	Ndrive HL Motor Power Board Fuse Information.....	6-6
Table 6-6.	Ndrive HL Motor Power Board Test Point Information	6-6
Table 6-7.	Jumper Selections (Line Voltage) on Power Supply Board.....	6-7
Table 6-8.	Jumper Selections (Bus Voltage) on Power Supply Board.....	6-7
Table 6-9.	Ndrive HL Power Supply Board Jumper Selections	6-8
Table 6-10.	Ndrive HL Power Supply Board Fuse Information.....	6-8
Table 6-11.	LED Indicator Description	6-9
Table 6-12.	JTAG Programming Connector – Internal (P10)	6-10
Table 6-13.	Ndrive HL Power Supply Board Fuse Information, (690D1588).....	6-11
Table 6-14.	Ndrive HL Motor Power Board Fuse Information, (690D1589).....	6-11
Table 6-15.	Battery Replacement Part Number (Ndrive HL Control Board)	6-11
Table 6-16.	Preventative Maintenance	6-12



DECLARATION OF CONFORMITY

Manufacturer's Name and Address: Aerotech, Inc.
101 Zeta Drive
Pittsburgh, PA 15238-2897

Declares that the product: **Ndrive HL**
Conforms to the following product specifications, with the exceptions listed below.

Safety: EN 61010-1:2001 Safety Requirements

Use: This product is intended for light industrial manufacturing or laboratory use.

and complies with 73/23/EEC low voltage directive.

Notes concerning EN 61010-1:

- Voltages greater than 60 Volts may be present inside the unit after a discharge time of 5 seconds.
- The unit must be installed within an enclosure with construction compliant unlimited circuits.
- The end user is responsible for meeting the final protective ground requirements.
- The AC power inlet located on the front (and control power on the top, if present) of the unit is the power disconnect. The end user is responsible for determining and providing a supply disconnect for the system.
- The end user is responsible for preventing unexpected startup.
- Connection requirements are described in the technical documentation provided with the product. The end user is responsible for making the proper connections and meeting any required interlock requirements for the product application.
- The end user must provide protection concerning power interruption / restoration, if required.
- The end user must provide earth fault current protection, if required.
- The end user must provide protection against lightning and power switching surges, if required.
- Control and Emergency Stop requirements are to be determined and provided by the end user.
- Wire and cabling provided with the unit meet Aerotech's electrical and listed environmental requirements. The end user must meet the final requirements.

Pittsburgh, PA
April, 2004

David F. Kincel 
Quality Assurance Manager

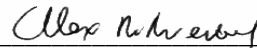
Alex R. Weibel 
Engineer Verifying Compliance

EMC Requirements:

The use of shielded cables is required to reduce radiated emissions. The cable shields must be connected to the metal back shell of D-type connectors, or to the nearest frame ground connection for other type connectors.

The following modifications will help ensure CE compliance:

- Install a snap-on Ferrishield ferrite attenuator, P/N SS28B2034, on the FireWire cable at the unit.
- Use a FireWire card with inductive common mode filters, such as the Aerotech NFIRE-PCI or Siig NN-403P12.

These modifications may not be necessary in the final installation of the product. Since the unit is a component, designed to be integrated with other electronics, EMC testing must be conducted on the final product configuration.



Failure to follow these procedures may result in serious injury, damage and/or excessive emissions or reduced immunity of the equipment.



CHAPTER 1: INTRODUCTION

Aerotech's Network Digital Linear Drive (Figure 1-1) (and PWM Ndrive CP, HP, MP, and Nservo, Npaq) complement the Automation 3200 System. Connected via the IEEE-1394 (FireWire®) communication bus, these drives provide deterministic behavior, auto-identification, and easy software setup from the Nmotion SMC software controller. Featuring a high-speed Harvard architecture DSP, the drives are linear for eliminating EMI/RFI emissions and have fully digital current and servo loops providing up to an 8 kHz servo loop closure, 32 MHz line driver encoder data rate, and an optional Ethernet port for access to third party networked I/O solutions. Additionally, one 18 bit analog output and one 16 bit analog input is standard. The Ndrive HL also features an optional on-board brake relay, programmable resolution multiplication up to x65,536, with a 200 kHz maximum amplified sine wave input frequency, and up to three-axis Position Synchronized Outputs (laser firing). In addition, the use of the commercially standard FireWire communication link makes integration to the Automation 3200 network plug-n-play easy.

This product is intended for light industrial manufacturing or laboratory use.



Figure 1-1. Ndrive HL Networked Digital Drive

1.1. Feature Summary

- Software configurable for brush (torque/current and tachometer mode) and brushless motor operation
- Bipolar 40 or 80 VDC bus power supply
- Fully isolated power stage
- 5 VDC, 500 mA user output power for encoder and Hall effect signals, etc.
- Two mounting orientations optimized for heat transfer or minimal panel space utilization
- Full protection against the following failure modes:
 1. Control supply under voltage
 2. Continuous current overload
 3. Power stage bias supply under-voltage
 4. Power stage output short circuit (phase to phase and phase to ground)
 5. DC bus over voltage
 6. IGBT device over temperature sense
- Line driver square wave or analog sine wave quadrature encoder primary position and velocity feedback
- Line driver square wave auxiliary quadrature encoder input or output for PSO (laser firing), etc.
- 4 opto-isolated user outputs standard
- 6 opto-isolated user inputs standard, 2 of which are high speed
- 2 differential analog inputs (one standard and one available with the –IOPSO option)
- 2 analog inputs (one standard and one available with the –IOPSO option)

1.2. Connection Overview

The Ndrive HL consists of a power connection (motor power and input power), three FireWire ports, an optional Ethernet connection, an RS-232/RS-422 connector, LED indicator lamps and two D-style connectors for Auxiliary I/O (15 and 26 pin) and Motor Feedback (25 pin). An -IOPSO/-IOPSOH option is also available, shown below (J301-J303, TB301-TB305), which has connections for PSO, absolute encoder, SSI Net, analog I/O, digital I/O, and user power. Refer to Figure 1-2 for locations.

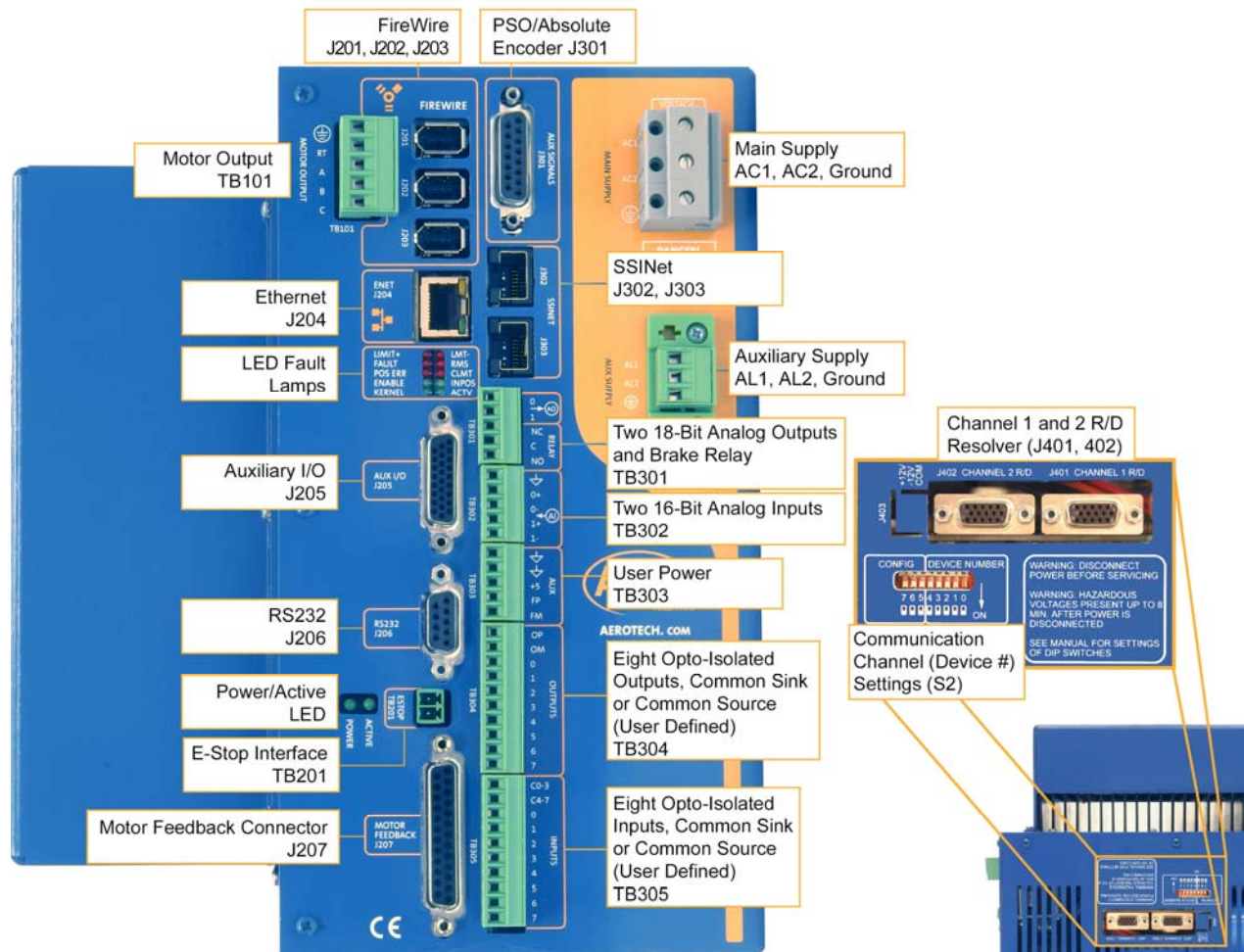

Figure 1-2. Ndrive HL Hardware

1.3. Ndrive HL Block Diagram

The standard package includes the bus power supply that operates from standard AC line voltage (100/115/208/230 factory configured). The power supply is included with the standard package for off-line operation without the need for an isolation transformer. Figure 1-3 is a functional diagram including options. In addition, a soft start circuit is included to prevent high inrush currents.

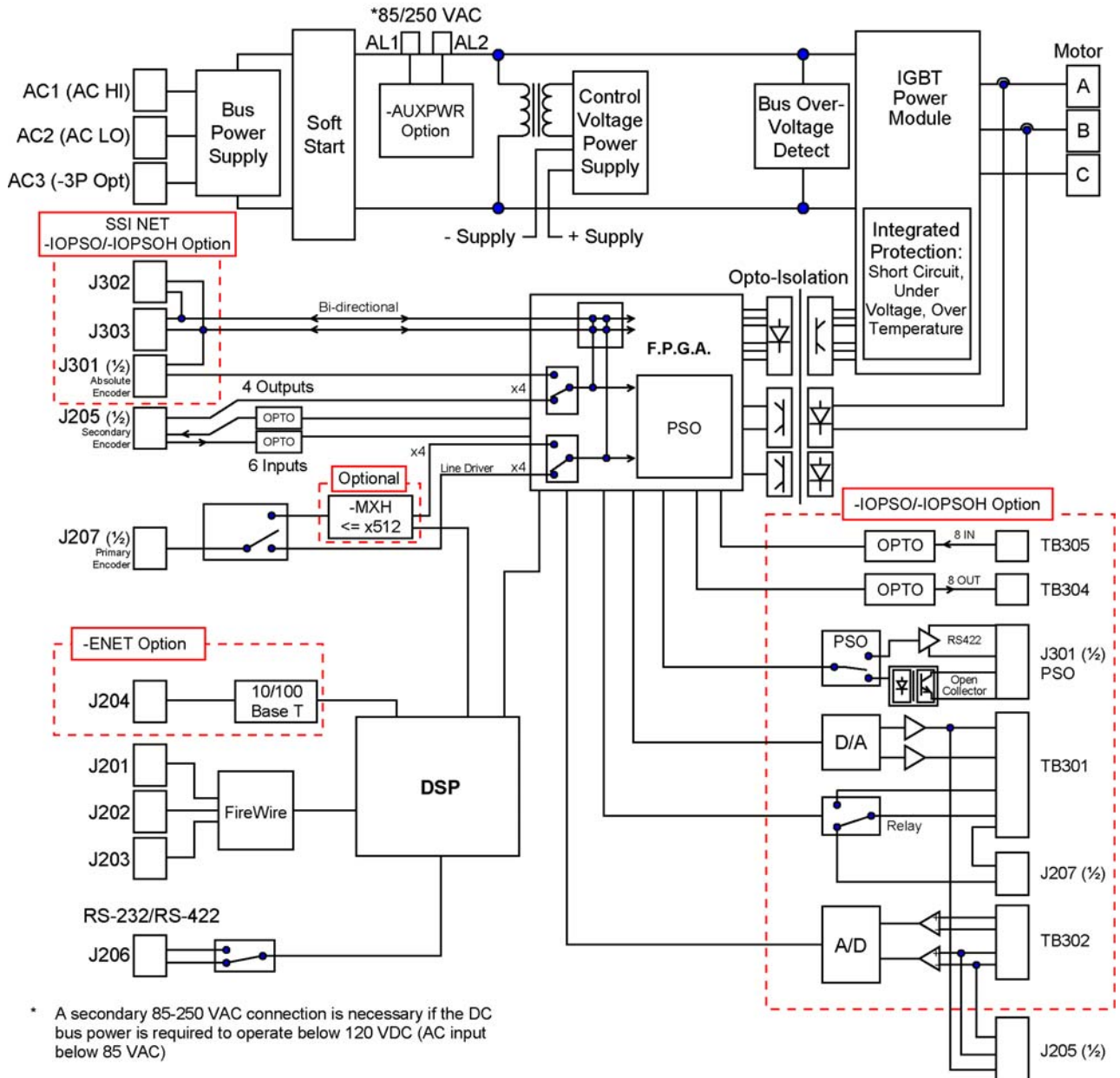

Figure 1-3. Ndrive HL Functional Diagram

1.4. Ordering Information

The Ndrive HL is available in three base models with continuous power, ranging from 675 to 1,350 watts. A list of these models, and the available voltage configurations, are shown in Table 1-1

Table 1-1. Ndrive HL Models and Voltage Configurations

Model	Standard Bus Voltage	Peak Output Current	Continuous Output Current (peak)
Ndrive HL-20-40	±40 VDC	20A	10A
Ndrive HL-10-80	±80 VDC	10A	5A
Ndrive HL-10-40	±40 VDC	10A	5A
Options			
-IOPSO and -IOPSOH	<ul style="list-style-type: none"> - One additional 18-bit analog outputs (±10 Volts) - One additional 16-bit differential analog inputs (±10 Volts) - One fail safe brake (or user) relay output - Eight optically isolated logic inputs (5 – 24 VDC), user defined as current sourcing or sinking. - Two bi-directional RS-422 encoder inputs/outputs (SSI Net) - One absolute/RS-485 encoder interface for secondary encoder channel - Optically isolated laser firing (PSO) output - Eight in/out optically isolated current sourcing/sinking logic outputs (5 - 24 VDC); rated for 1 ampere on the -IOPSOH option. 		
-DUALPSO	Two axis Position Synchronized Output (Laser Firing)		
-TRIPLEPSO	Three axis Position Synchronized Output (Laser Firing)		
-PSOOPTO1	Opto-isolator for PSO, requires the -IOPSO option (<5V, high speed, high current, HCPL2601)		
-PSOOPTO2	Opto-isolator for PSO, requires the -IOPSO option (<15V, high speed, low current, 6N136)		
-PSOOPTO3	Opto-isolator for PSO, requires the -IOPSO option (<30V, low speed, high current, 4N33)		
-PSOOPTO4	Opto isolator for PSO (5-25VDC, 40kHz, 50mA, TIL117-M)		
-MXH	Programmable encoder multiplier up to x2,048, supports PSO (laser firing) and encoder quadrature output		
-ENET	10/100BASE-T Ethernet port for I/O expansion		
MCK-NDRIVE	Mating connector kit for J206 and J207 (J205 is always provided)		
-AUXPWR	Auxiliary 85-240 VAC input to power logic circuitry. Required for "keep alive" or 20-80 VDC bus operation. 20-120 VDC operation requires external transformer to generate 15-85 VAC bus power input.		
J1	Optional Industrial Joystick		

1.5. Electrical Specifications

The electrical specifications for the Ndrive HL are listed in Table 1-2.

Table 1-2. Electrical Specifications

Description		Units	20-40	10-40	10-80
Main Supply Input Voltage		VAC	100, 115, 200, 230 (model dependent)		
Main Supply Input Frequency		Hz	50-60		
Main Supply Inrush Current		A	23	23	23
Optional Supply Input Voltage		VAC	85-240		
Optional Supply Input Frequency		Hz	50-60		
Optional Supply Maximum Input Power		Watts	100		
Voltage Output (brushless) ⁽¹⁾		VDC	80	80	160
Output Voltage (brush)		VDC	40	40	80
Current Peak Output ⁽²⁾		A _{pk}	20	10	10
Current Continuous Output ⁽²⁾		A _{pk}	10	5	5
Power Peak Dissipation (per phase)		Watts	360		
Power Peak Output ⁽³⁾		Watts	1,350	675	1,350
Power Continuous Output		Watts	675	337	675
Power Amplifier Gain (each phase)		A/V	2	1	1
Power Amplifier Bandwidth ⁽⁴⁾		kHz	2		
Minimum Load Inductance		mH	0		
Minimum Load Resistance (line-to-neutral)		Ohms	0.5		
Operating Temperature		°C	0 to 50		
Storage Temperature		°C	-30 to 85		
Weight	Standard	lb (kg)	22.0 (9.98)		
	-IOPSO or -IOPSOH option		22.2 (10.07)		

1. Ndrive HLs can drive each of its phases rail to rail since the drive supply for each phase is not derived from the +/- bus voltages.
2. Peak and continuous output current is load dependent, see Table 1-3.
3. This specification based on the output power transistors in the saturated (e.g., full on) condition.
4. Into an Aerotech BLM-203-A linear forcer ($R_{LL} = 4\Omega$, $L_{LL} = 3.2\text{ mH}$)

Table 1-2. Electrical Specifications (continued)

Specification	Description	
Modes of Operation	Brushless	
	Brush (Current/Torque and tachometer Mode)	
Feedback Inputs	Hall A-Pin 10, Hall B-Pin 5, Hall C-Pin 11: Hall effect device inputs for commutation, 0 to 5 VDC, internal pull-up, 10K input. Commutation signals used with brushless motors to provide motor rotation position information to the amplifier. This allows the amplifier to steer the three phases of the motor currents in such a fashion to provide rotation of the motor in the desired direction at the desired speed. TTL level input.	
	Sine/Sine-N, Pin 17/Pin 18, Cosine/Cosine-N, Pin 14/Pin 15: Encoder input 0 to 5VDC, internal pull-up, 10K input.	
Power Inputs (AC1, AC2)	AC input: AC1, AC2, earth ground (⊕), 50-60 Hz, single phase.	
Auxiliary Power Outputs (AL1, AL2)	5V-Pin 16: On board 5V power supply. 250 mA max. output.	
	5V-Pin 3: On board 5V power supply. Pin 3 is intended for powering an encoder. Ndrive HL can supply up to 500 mA of current total to user devices.	
Protective Features	Output short circuit	Peak over current
	DC bus over voltage	RMS over current
	Over temperature	Control power supply under voltage
	Power stage bias supply under voltage	Designed to EN61010/UL3101
Isolation	Optical and transformer isolation between control and power stages.	
Indicator (Power)	LED indicates drive power.	
Indicator (Enabled)	LED indicates drive enabled.	

Table 1-3. Ndrive HL Series Amplifier Current Limitations

R _{L-L} (Ohms)	Ndrive HL10-40 T _{ambient} = 25°C		Ndrive HL10-40 T _{ambient} = 50°C		Ndrive HL20-40 T _{ambient} = 25°C		Ndrive HL20-40 T _{ambient} = 50°C		Ndrive HL10-80 T _{ambient} = 25°C		Ndrive HL10-80 T _{ambient} = 50°C	
	I _{PK} ¹⁾ Limit (Amps)	I _{PK-CONT} ²⁾ Limit (Amps)	I _{PK} Limit (Amps)	I _{PK-CONT} Limit (Amps)	I _{PK} Limit (Amps)	I _{PK-CONT} Limit (Amps)	I _{PK} Limit (Amps)	I _{PK-CONT} Limit (Amps)	I _{PK} Limit (Amps)	I _{PK-CONT} Limit (Amps)	I _{PK} Limit (Amps)	I _{PK-CONT} Limit (Amps)
0.5	10.0	5.00	10.0	4.50	14.5	6.50	14.5	4.50	6.5	3.25	6.5	2.25
1	10.0	5.00	10.0	4.50	16.0	7.00	16.0	4.50	7.0	3.25	7.0	2.25
1.5	10.0	5.00	10.0	4.75	18.5	7.50	18.5	4.75	7.0	3.25	7.0	2.25
2	10.0	5.00	10.0	4.75	20.0	7.75	20.0	4.75	7.0	3.25	7.0	2.25
2.5	10.0	5.00	10.0	5.00	20.0	8.25	20.0	5.00	7.5	3.25	7.5	2.25
3	10.0	5.00	10.0	5.00	20.0	9.00	20.0	5.25	7.5	3.50	7.5	2.25
3.5	10.0	5.00	10.0	5.00	20.0	10.00	20.0	5.25	7.5	3.50	7.5	2.25
4	10.0	5.00	10.0	5.00	20.0	10.00	20.0	5.50	8.0	3.50	8.0	2.25
4.5	10.0	5.00	10.0	5.00	*	10.00	*	6.00	8.0	3.50	8.0	2.25
5	10.0	5.00	10.0	5.00	*	10.00	*	6.50	8.5	3.50	8.5	2.25
5.5	10.0	5.00	10.0	5.00	*	10.00	*	7.25	8.5	3.50	8.5	2.25
6	10.0	5.00	10.0	5.00	*	10.00	*	10.00	9.0	3.75	9.0	2.25
6.5	10.0	5.00	10.0	5.00	*	10.00	*	10.00	10.0	3.75	10.0	2.25
7	10.0	5.00	10.0	5.00	*	10.00	*	10.00	10.0	3.75	10.0	2.25
7.5	10.0	5.00	10.0	5.00	*	10.00	*	10.00	10.0	3.75	10.0	2.25
8	10.0	5.00	10.0	5.00	*	10.00	*	10.00	10.0	3.00	10.0	2.50
8.5	*	5.00	*	5.00	*	*	*	*	10.0	4.00	10.0	2.50
9	*	5.00	*	5.00	*	*	*	*	10.0	4.00	10.0	2.50
9.5	*	5.00	*	5.00	*	*	*	*	10.0	4.00	10.0	2.50
10	*	5.00	*	5.00	*	*	*	*	10.0	4.25	10.0	2.50
10.5	*	5.00	*	5.00	*	*	*	*	10.0	4.25	10.0	2.50
11	*	5.00	*	5.00	*	*	*	*	10.0	4.25	10.0	2.50
11.5	*	5.00	*	5.00	*	*	*	*	10.0	4.50	10.0	2.50
12	*	5.00	*	5.00	*	*	*	*	10.0	4.50	10.0	2.50
12.5	*	5.00	*	5.00	*	*	*	*	10.0	4.75	10.0	2.50
13	*	5.00	*	5.00	*	*	*	*	10.0	4.75	10.0	2.50
13.5	*	5.00	*	5.00	*	*	*	*	10.0	5.00	10.0	2.50
14	*	5.00	*	5.00	*	*	*	*	10.0	5.00	10.0	2.50
14.5	*	5.00	*	5.00	*	*	*	*	10.0	5.00	10.0	2.75
15	*	5.00	*	5.00	*	*	*	*	10.0	5.00	10.0	2.75
15.5	*	5.00	*	5.00	*	*	*	*	10.0	5.00	10.0	2.75
16	*	5.00	*	5.00	*	*	*	*	10.0	5.00	10.0	2.75
16.5	*	*	*	*	*	*	*	*	*	*	*	*

*Limited by: $V_{BUS}/(R_{LL}/2)$ **Definitions:**

R _{LL}	motor resistance (line-to-line)
I _{PK}	peak output current that the amplifier will sustain for 1 second when running a three phase commutated motor
I _{PK-CONT}	peak value of a continuous sine wave

Notes:

I _{PK} limit	ensures that an instantaneous current pulse does not harm the output transistors.
I _{PK-CONT} limit	ensures that the temperature of the amplifier does not reach a value that would harm the semiconductor devices.

1.6. Mechanical Specifications

Units should be separated from each other and surrounded by one inch of free air space. This will also allow the standard nine-inch (228 mm) FireWire cable to interconnect them.

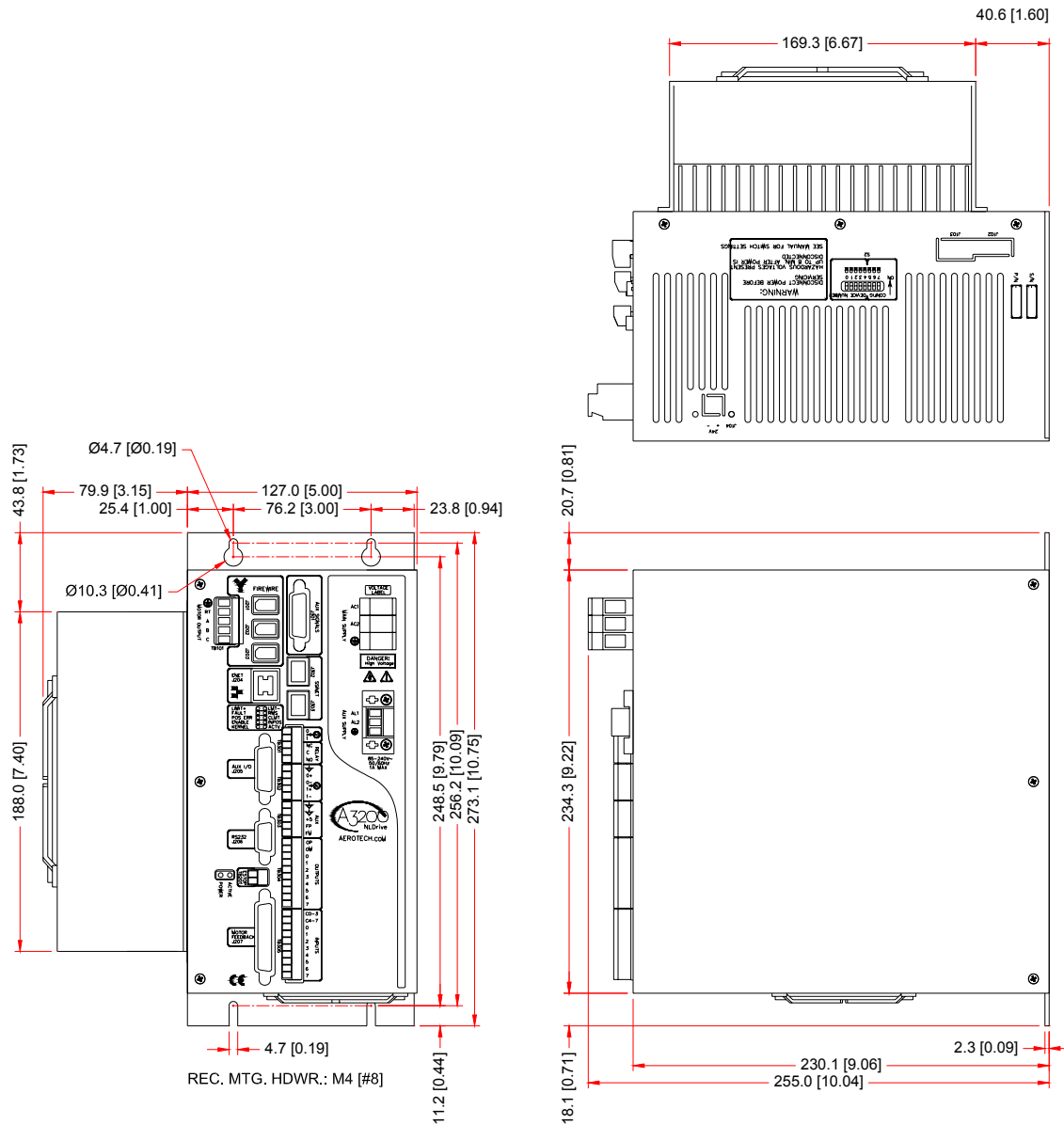

Figure 1-4. Ndrive HL Dimensions



The Ndrive HL case temperature may exceed 75°C in some applications.

1.7. Environmental Specifications

The environmental specifications for the Ndrive HL are listed below.

- Temperature: Ambient
 - Operating - 5° - 40°C (41° - 104°F)
 - Storage - -20 – 70°C (-4 – 158°F)
- Humidity: Maximum relative humidity is 80% for temperatures up to 31°C. Decreasing linearly to 50% relative humidity at 40°C. Non-condensing.
- Altitude Up to 2000 m.
- Pollution Pollution degree 2 (normally only non-conductive pollution).
- Use Indoor use only.

▽ ▽ ▽

CHAPTER 2: INSTALLATION and CONFIGURATION

This section covers the hardware configurations using the switches, jumpers, connectors, and power connections when used with a brush or brushless motor. Wiring, grounding, shielding techniques, and the motor phasing process are also covered.

Aside from the obvious requirements of AC input power and motor wiring, the only other typical requirement is to define the Ndrive HLs communication channel number via switch S2 (see Section 2.7).

2.1. Safety Procedures and Warnings

The following statements apply wherever the Warning or Danger symbol appears within this manual. Failure to observe these precautions could result in serious injury to those performing the procedures and/or damage to the equipment.



If the equipment is used in a manner not specified by the manufacturer, the protection by the equipment may be impaired. The user should practice caution when following the given procedures. Deviation from this may result in damage to the equipment or machinery.



To minimize the possibility of electrical shock and bodily injury, ensure that the motor is decoupled from the mechanical system and no harm to personnel will result if the motor begins to spin.



To minimize the possibility of electrical shock and bodily injury when any electrical circuit is in use, ensure that no person is exposed to the circuitry.



To minimize the possibility of bodily injury, make certain that all electrical power switches (all switches external to the amplifier) are in the off position prior to making any mechanical adjustments.

2.2. Power Connections

The Ndrive HL may be powered by one or two separate AC voltages. One for motor bus power and optionally a second for control power, as described in the following two subsections. If the optional control power input is present, it must be powered.

2.2.1. Control Power Connections (-AUXPWR)

The -AUXPWR option allows the Ndrive HL to remain operational when the motor power is removed, such as when an emergency stop circuit is required. If the Ndrive HL was purchased with the -AUXPWR option, a separate AC input has been included on the amplifier. The internal power supply of the Ndrive HL requires a minimum of 85 VAC input to operate properly. The figure below shows the connection to the -AUXPWR AC input. The connection is made via a three terminal connector. See Section 2.4 for various typical AC wiring options. This optional input is used when an external emergency stop circuit is present. See Section 2.3 for a typical ESTOP wiring configuration.

The AUXPWR control power inputs (AL1, AL2) are optional, but **must be powered if present**. These inputs are typically used when an external emergency stop circuit is present. Connections to the AL1, AL2 inputs and the protective Ground  should be at least 1.62814 mm (#14 AWG) wire rated @ 300 V (3 Amp external fusing may be required for AL2, AL1 is fused internally at 3 Amps).

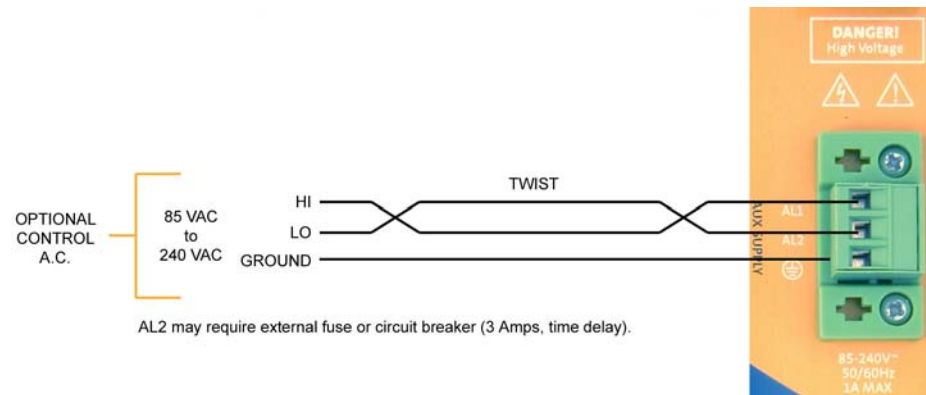



Figure 2-1. -AUXPWR Option

Table 2-1. Optional Aux Supply AC Input (for external E-Stop)

Pin	Description	Wire Size
AL1	Optional 85-240 VAC Control Power Input	1.62814 mm (#14 AWG)
AL2	Optional 85-240 VAC Control Power Input	1.62814 mm (#14 AWG)
	Protective Ground (Required for Safety)	1.62814 mm (#14 AWG)

2.2.2. Motor Power Connections

Input power to the Ndrive HL is made at the **AC1** and **AC2** terminals with earth ground connected to Ⓧ (ground). The motor frame and shield connect to Ⓧ (ground) as well. Connections at the AC1, AC2 and Protective Ground connections should be made with 1.62814 mm (#14 AWG) wire rated at 300V.

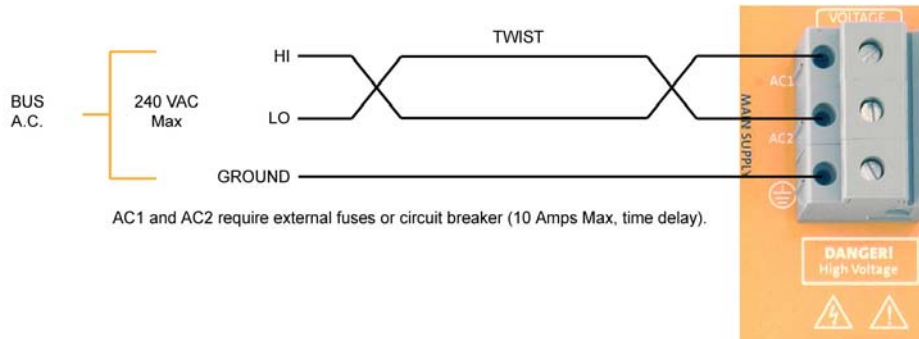
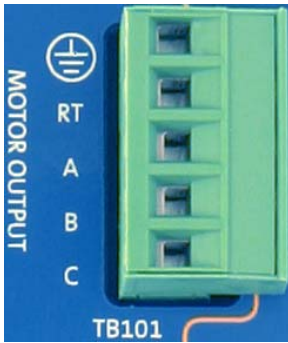

Figure 2-2. Motor Power Connections

Table 2-2. Main Supply AC Power Input Connections

Pin	Description	Wire Size
AC1	115/100/208/230 Volt AC Input	1.62814 mm (#14 AWG)
AC2	115/100/208/230 Volt AC Input	1.62814 mm (#14 AWG)
Ⓧ	From Earth Ground (Required for Safety)	1.62814 mm (#14 AWG)

External fuses or circuit breaker (10 Amperes, time delay type) are required for the AC1 and AC2 AC inputs for optimum protection. The protective devices should be located near the Ndrive HL.



2.2.3. Motor Connections (TB101)

The three-phase motor terminal connections are made at connections **A**, **B**, **C** and optionally at **RT**. The **RT** connection is only used for brushless motors having a fourth motor lead, as in a Wye configuration. Motor Connections $\emptyset A$, $\emptyset B$, $\emptyset C$ and its Protective Ground should be made with 1.62814 mm (#14 AWG) wire rated at 300 V. The motor frame and shield must be connected to \oplus (ground) as well. See Section 2.4 for information on connecting each of the supported motor types.

Table 2-3. TB101 Motor Power Output Connections

Pin	Description	Wire Size
$\emptyset A$	Phase A Motor Lead	1.62814mm (#14 AWG)
$\emptyset B$	Phase B Motor Lead	1.62814mm (#14 AWG)
$\emptyset C$	Phase C Motor Lead	1.62814mm (#14 AWG)
RT	Brushless Motors with Wye connection only	1.62814mm (#14 AWG)
\oplus	Earth Ground to Motor (Required for Safety)	1.62814mm (#14 AWG)

2.2.4. I/O and Signal Wiring Requirements

The I/O, communication, and encoder feedback connections are typically very low power connections. Wire and connectors used for signal wiring should be rated for at least 30 V and have a current capacity of at least .25 Amp. Wires and connectors used for low voltage power connections such as +5V should have a current capacity of at least 1 Amp (encoder feedback +5V supply may require .6 Amps in some applications). In some applications, especially when there are significant wire distances, a larger wire size may be required to reduce the voltage drop that occurs along the wire. This increase may be necessary in order to keep the voltage within a specified range at a remote point.

When signal wiring is in close proximity to wiring operating at voltages above 60 Volts the insulation rating of the signal wiring will also need to be rated for the higher voltage. Signal wiring should have a voltage rating of at least 300 Volts when in proximity to AC power or motor power wiring.

2.3. Emergency Stop Sense Input (TB201)

This input is intended to be activated by an external fail-safe emergency stop circuit. It is not intended to be an emergency stop circuit in itself. It is scaled for an input voltage of 5-24 volts. Using a higher input voltage requires adding an external series resistor to limit the current.

If the ESTOP bit is enabled in the FaultMask axis parameter, the ESTOP input must be driven to prevent the ESTOP fault condition.

For typical ESTOP wiring, see the following two drawings.

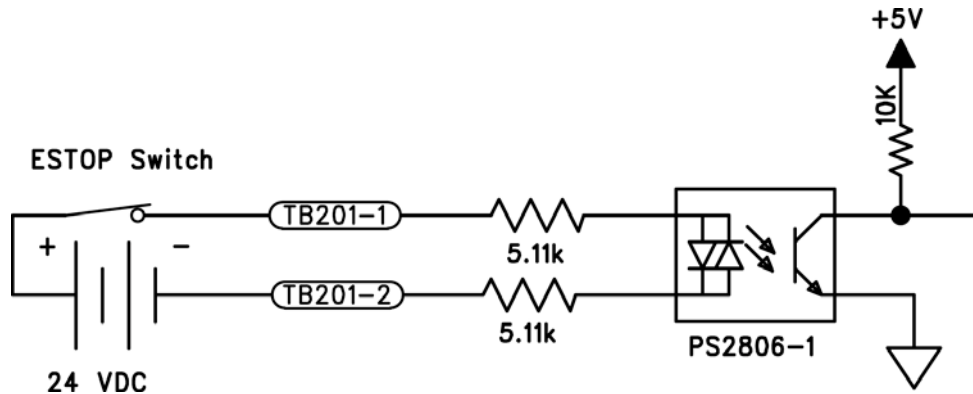

Figure 2-3. ESTOP Sense Input (TB201)



Connecting the E-Stop input to a relay or other EMI/RFI noise producing device/circuit, requires one or more noise suppression devices, such as those in Table 2-4, or other appropriate devices.

Table 2-4. Electrical Noise Suppression Devices

Device	Aerotech P.N.	Third party P.N.
RC (.1uf / 200 ohm) Network	EIC240	Electrocube RG1782-8
Varistor	EID160	Littlefuse V250LA40A

2.3.1. Typical ESTOP Interface

The user may connect an emergency stop circuit to the Ndrive HL. It will disable power to the motor by removing power to the power stage of the drive, while maintaining power to the control section, as shown in the following Figure 2-4.

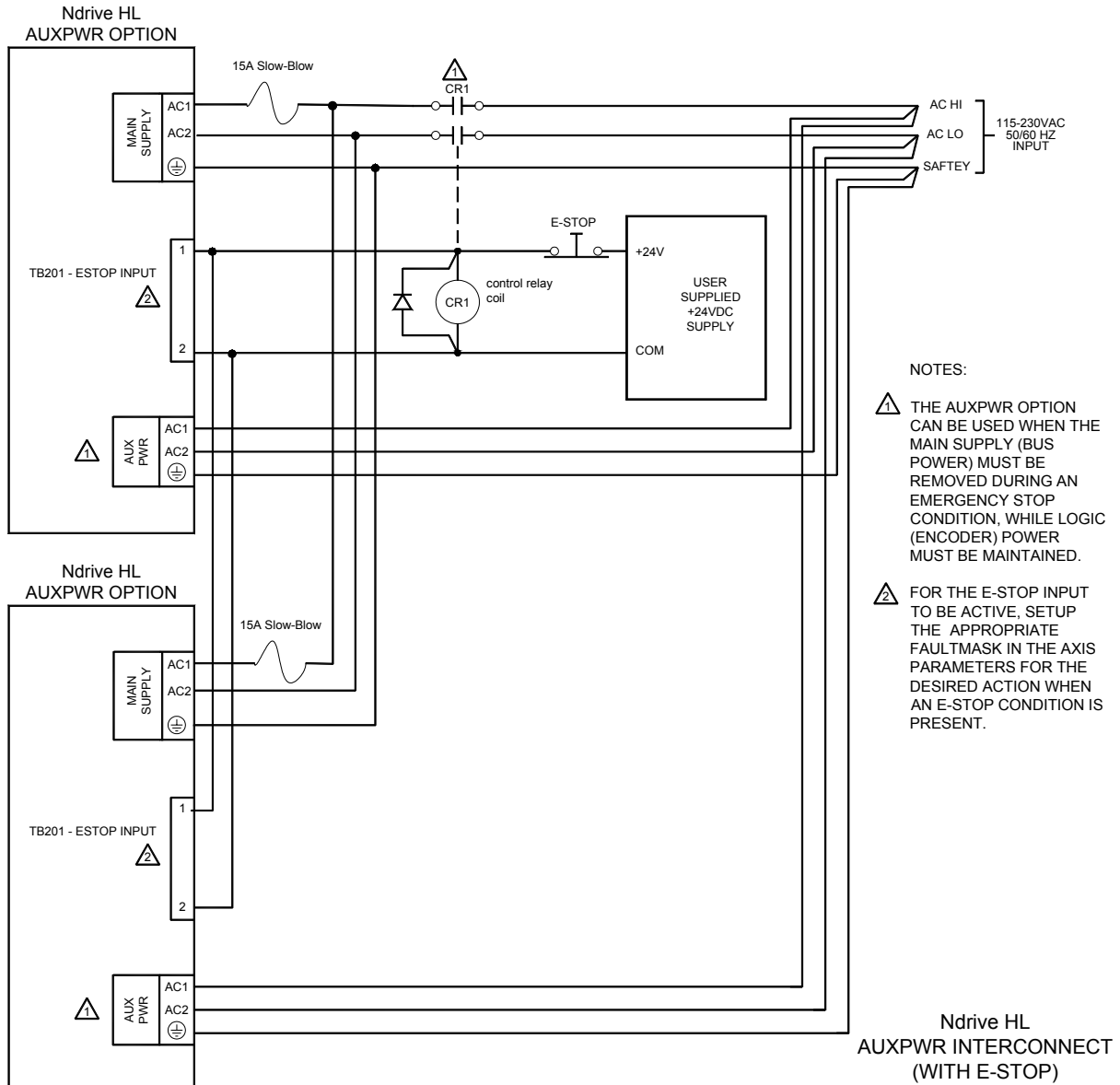

Figure 2-4. Typical Emergency Stop Circuit

2.4. Motor and Feedback Connections

The Ndrive HL can be integrated into a system using three basic configurations: DC Brush (Velocity and Torque mode), brushless or stepper motors. Brush and brushless motors may have two feedback devices.

2.4.1. DC Brush Motor in Torque Mode Configuration

The DC brush motor configuration is shown in Figure 2-5. See section 2.5.1. for the correct encoder phasing information if Aerotech’s standard cabling is not used.

Consult the drawing (located on your software CD ROM) for specific cable information.

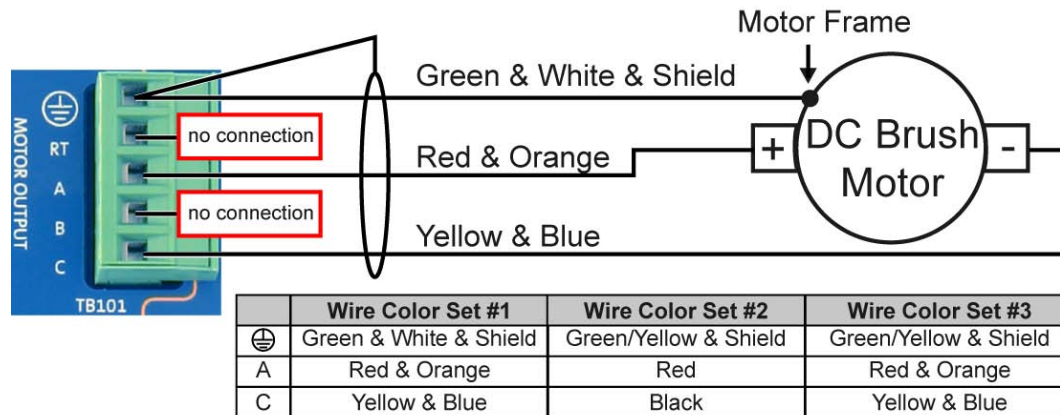

NOTES: "&" (Red & Orange) implies two wires,
 "/" (Green/Yellow) implies a single wire

Figure 2-5. DC Brush Motor in Torque Mode Configuration

2.4.1.1. DC Brush Motor Phasing

If an Aerotech motor is used with Aerotech provided cabling, no motor phasing process is required.

A DC brush motor is phased correctly, when a positive motion command causes clockwise (CW) motor rotation, as viewed looking at the motor from the front mounting flange. This assumes the CntsPerMetricUnit/CntsPerEnglishUnit/CntsPerRotaryUnit axis parameters are set to a positive value. This required phasing, is determined solely by which motor lead is connected to the ØA and ØC motor terminals. Motor phasing is unrelated to the resultant direction of motion commanded from within a motion program. After correctly phasing the motor, you may reverse the motor direction when commanding a positive move from a motion program, by negating the sign of the CntsPerMetricUnit/CntsPerEnglishUnit/CntsPerRotaryUnit axis parameters.

To determine this, connect a voltmeter to the motor leads of an un-powered motor. Rotate the motor by hand clock-wise (CW). Swap the voltmeter connections to the motor until the voltmeter indicates a positive voltage. The motor lead now connected to the positive lead of the voltmeter, is the + motor lead as indicated in the Figure above, and should be connected to the ØA motor terminal. The other motor lead connects to the ØC motor terminal.

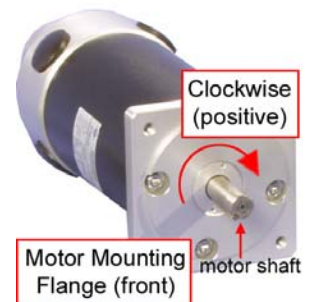

2.4.2. DC Brush Motor with Tachometer Feedback Configuration

The DC brush motor configuration is shown in Figure 2-6. See section 2.5.1. for the correct encoder phasing information if Aerotech's standard cabling is not used. The tachometer may be connected to TB302 or J205 as shown in the picture below. Note, that tachometer feedback uses analog input 0, so it may not be used when tachometer feedback is used. To configure the axis parameters in this mode, see the "Brush Motors in Velocity Mode" topic in the Nview HMI help.

The analog input that the tachometer is connected to is scaled for $\pm 10V$ input maximum. The tachometer voltage must not exceed ± 10 volts or the velocity loop will become unstable, possible causing a runaway condition. Based upon the tachometer voltage rating, a resistor-scaling network may be required to limit the tachometer voltage to $\pm 10V$ at maximum speed. If noise is present on the tachometer leads, a high quality 1 μF capacitor may be required across the tachometer leads, before any voltage divider, required to limit the maximum input voltage to the analog input.

The motor and tachometer are correctly phased, when rotated clockwise by hand and the tachometer generates a positive voltage as displayed on analog input 0 and the motors back EMF generates a negative voltage at motor terminal A (with the voltmeter common probe at motor terminal C).

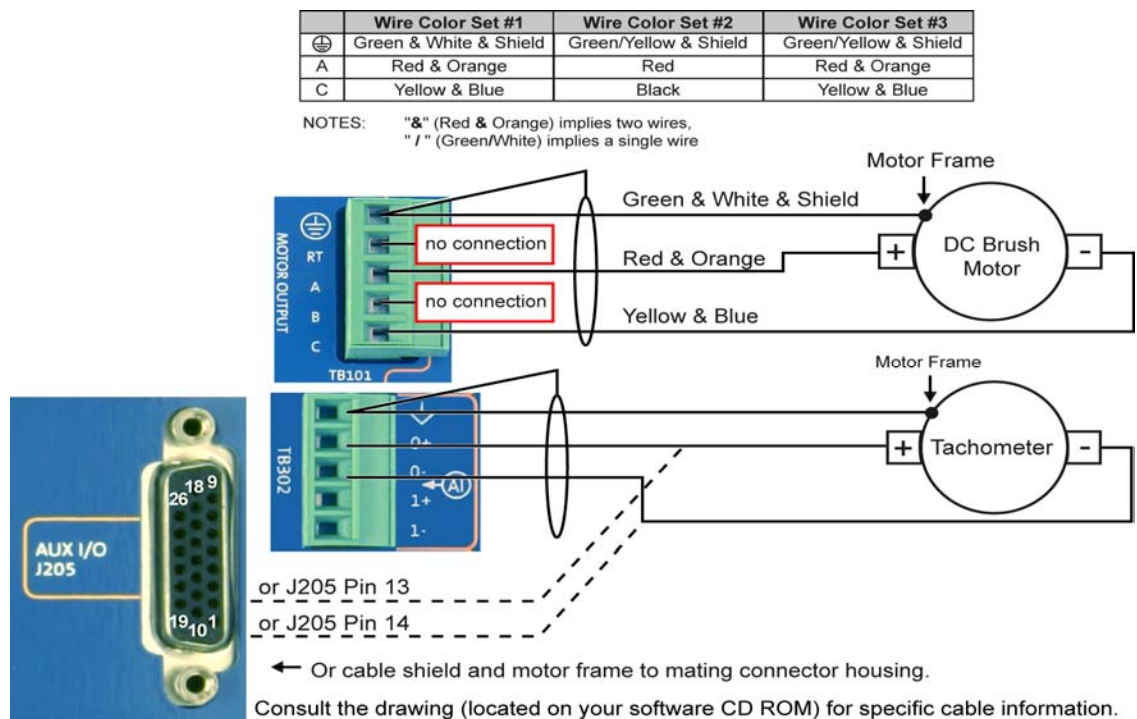

Figure 2-6. DC Brush Motor Wiring with Tachometer

2.4.3. Brushless Motor Configuration

This mode is used with a brushless motor only. See section 2.5., if Aerotech's standard cabling is not used, for information on correctly phasing the motor, encoder and Hall feedback devices.

Consult the drawing (located on your software CD ROM) for specific cable information.



Figure 2-7. Brushless Motor Configuration

2.4.3.1. Brushless Motor Phasing

When configuring the Ndrive HL to run a non-Aerotech brushless motor, the motor leads (A, B and C on TB101) must be correctly connected for proper operation. If an Aerotech motor is used with Aerotech provided cabling, no motor phasing process is required.

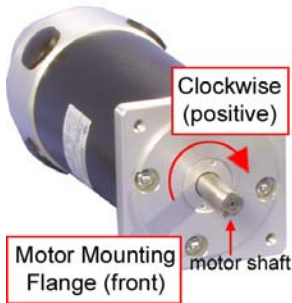

If an Aerotech brushless motor is used with the Ndrive HL, motor phase and HALL connections can be easily determined by referring to the system interconnection drawing in Figure 2-7.



Be sure to configure all axes with the Nparam.exe utility before running the A3200\Programs\Samples\MsetDebug.Pgm. See the "Getting Started" section in the Nview help for configuration information.

An AC brushless motor is correctly phased, when a positive motion command causes clockwise (CW) motor rotation, as viewed looking at the motor from the front mounting flange. This assumes a positive CntsPerMetricUnit/ CntsPerEnglishUnit /CntsPerRotaryUnit axis parameter. This required phasing is determined by which motor lead is connected to the ØA, ØB and ØC motor terminals.

Motor phasing is unrelated to the direction of motion commanded from within a motion program. After correctly phasing the motor, you may reverse the motor direction when commanding a positive move from a motion program, by negating the sign of the CntsPerMetricUnit/CntsPerEnglishUnit/CntsPerRotaryUnit axis parameter.

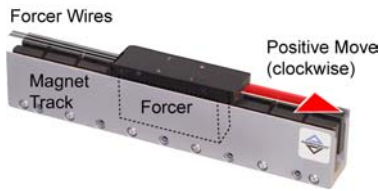

Motor phasing may be determined by two methods. The first of which, is by actively driving the motor open loop, under program control. The A3200\Programs\Samples\MsetDebug.Pgm may be used for this purpose. The motor phasing is correct when the program causes the motor to move in a positive direction, as defined in Figure 2-13. Swapping any two motor lead connections will correct a reversed motor rotation.

The second method is a non-powered method, whereby the motor is disconnected from the controller and connected in the test configuration as defined in Figure 2-10. This will identify motor (and Hall signal) leads A, B and C. These sequences and the generated output motor phase voltages (motor output connections A, B, and C) are shown in Figure 2-10. The voltages generated are made by moving the motor/forcer by hand in a positive (CW) motion direction.

2.4.3.2. Brushless Motor Hall-Effect Feedback Connections

The Hall-Effect feedback signals on an AC brushless motor are correctly phased when the hall states correspond to the states at each of the electrical angles shown in Figure 2-10. The hall states, which correspond to the electrical angles are indicated in Figure 2-10. A "0" for the given Hall input indicates zero voltage or logic low, where a "1" indicates five volts or logic high. These logic levels may be viewed within the Nstat utility, on the Diagnostic tab, as shown in Figure 2-9.

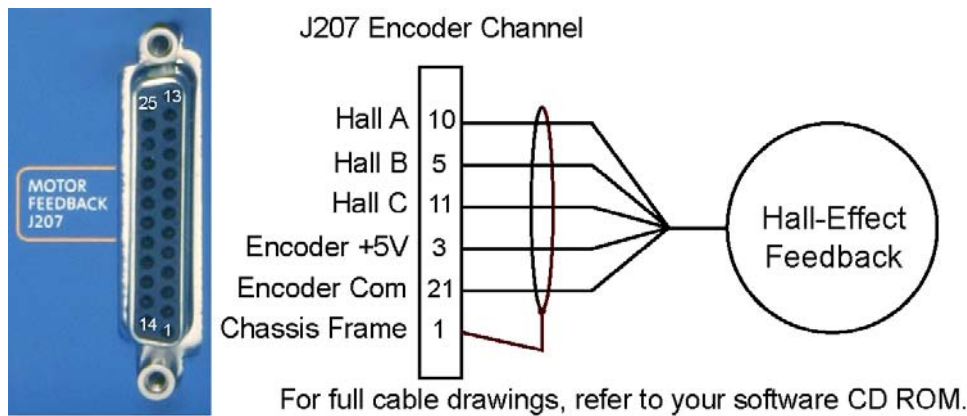

Figure 2-8. Hall-Effect Feedback Connections

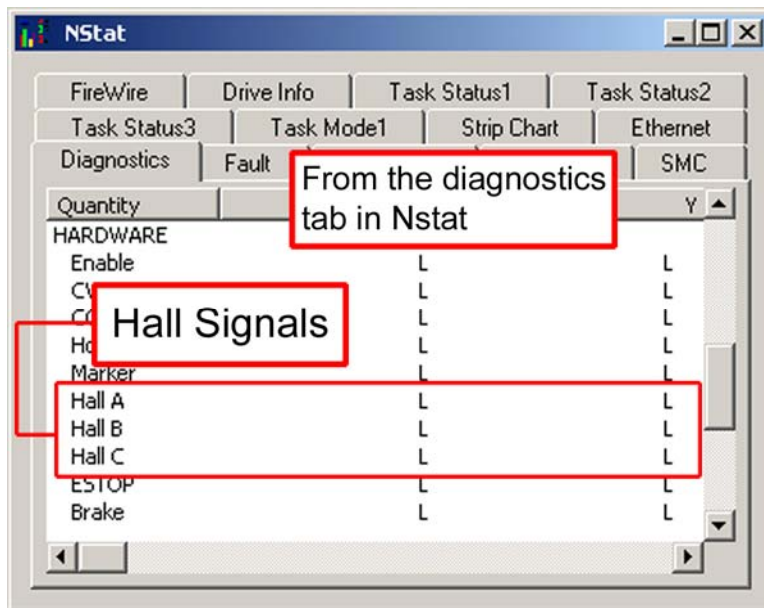

Figure 2-9. Hall-Effect Feedback Inputs in the Nstat Utility

2.4.3.3. Hall-Effect Phasing

For an AC brushless motor with an unknown phase/hall sequence, one of two simple tests can be performed on the motor to determine the proper connections to the Ndrive HL.

NOTE



Be sure to first configure the axis parameters before running the A3200\Programs\Samples\MsetDebug.Pgm. See the “Getting Started” section in the Nview help for configuration information.

The first of which, is by actively driving the motor under program control. The A3200\Programs\Samples\MsetDebug.Pgm may be used for this purpose, as well as for motor lead phasing. The hall signal wiring must be swapped until they generate the sequence as defined in the Nview help, which the test program will display. After the hall sequence is correct, the program can then correctly determine if a commutation offset is required. The test program will indicate the required value of the CfgMotOffsetAng axis parameter to correctly phase the motor.

The second method is a non-powered method, whereby the motor is disconnected from the controller and connected in the test configuration as defined in Figure 2-10. This will identify the hall signals (and motor leads) A, B and C. The equipment needed for the non-powered test is a two-channel oscilloscope and three resistors (typically 10 K ohm, 1/2 watt) wired in a Wye configuration.



Before performing the test in Figure 2-10, ensure that the motor leads are completely disconnected from the amplifier.

NOTE



The tests outlined below do not require that the amplifier be powered since Figure 2-10 illustrates the generated output voltage of the amplifier relative to the input Hall sequences.

Connect the ends of the three resistors to motor terminals A, B, C. Use one channel of the oscilloscope to monitor motor terminal A with respect to the Wye neutral (i.e., the point where all three resistors are connected together). Turn the shaft of the motor CW and note the generated voltage. This voltage represents the phase A to neutral Counter EMF (CEMF). With the second oscilloscope probe, determine the Hall switch that is in phase with this voltage. Similarly, phase B and C should be aligned with the other two Hall switches. This will identify each motor and hall lead set, which are in-phase with each other. Any motor and hall lead set may be phase A. The relative phasing between this set and the other two sets will then determine which is phase B and phase C.

Refer to Figure 2-10 and note the generated output voltages of the amplifier relative to the Hall sequences applied to **HALL A, HALL B, and HALL C** connections at connector J207. For proper operation, the CEMF generated motor phase voltages should be aligned to the amplifier's generated output voltage with the Hall effect reference sequence shown in Figure 2-10.

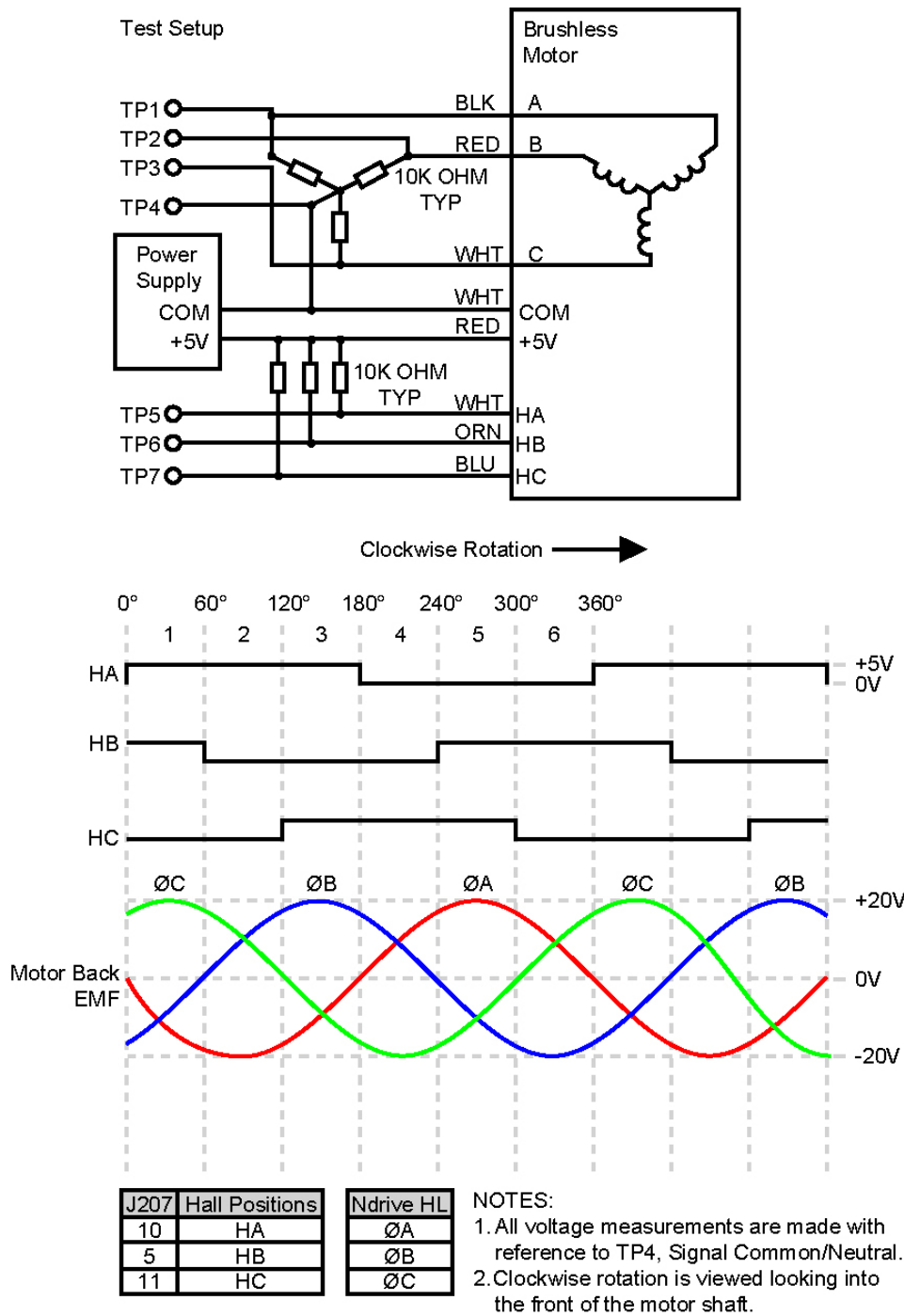

Figure 2-10. Motor Phasing

2.4.4. Stepper Motor Configuration

This mode is used with a stepper motor only. See section 2.5.1., if Aerotech's standard cabling is not used for information on correctly phasing the motor feedback devices.

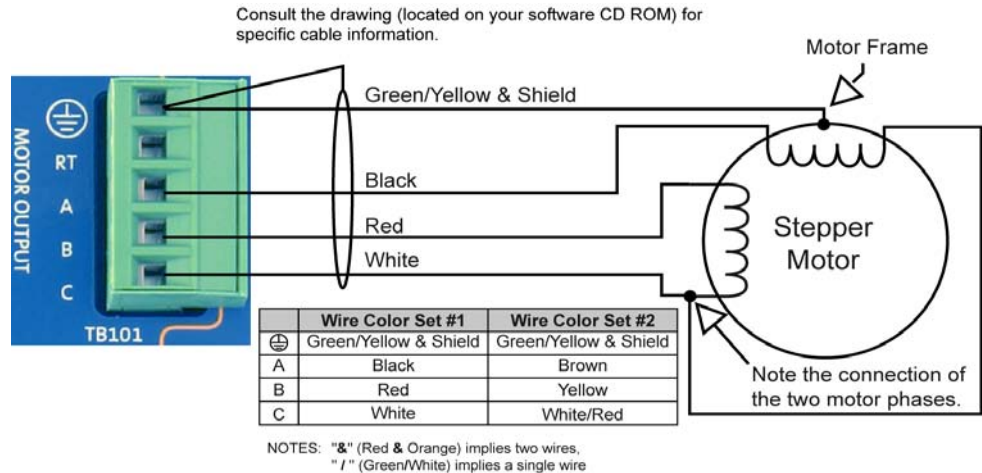

Figure 2-11. Stepper Motor Configuration

2.4.4.1. Stepper Motor Phasing Process

A stepper motor is phased correctly when a positive motion command causes the motor to rotate in a clockwise (CW) direction, assuming a positive scaling factor, as determined by the CntsPerMetricUnit/CntsPerEnglishUnit/CntsPerRotaryUnit axis parameter. To correct the phasing, reverse the connections to the θA and θB terminals on the Ndrive HL. This is important because the end of travel (EOT) limit inputs are relative to motor rotation. After correctly phasing the motor, you may reverse the motor direction when commanding a positive move from a motion program, by negating the sign of the CntsPerMetricUnit/CntsPerEnglishUnit/CntsPerRotaryUnit axis parameter.

2.5. Encoder Feedback Connections

One encoder feedback device must be used for all motor types, except for stepper motors. Each of the two encoder channels in the Ndrive HL, accept a differential line driver encoder, or with the -MXH option, the primary encoder channel, J207 accepts an analog sine wave encoder. DC Brush and brushless motors may have a separate position and a velocity feedback device. An analog sine wave encoder may be used with Aerotech's MXH multiplier box to multiply the encoder resolution and simultaneously convert it to a differential line driver encoder signal, acceptable by the Ndrive HL.

NOTE



Signal shielding is very important and the wiring should be physically isolated from motor, AC power and all other power wiring.

J207 Primary Encoder Channel

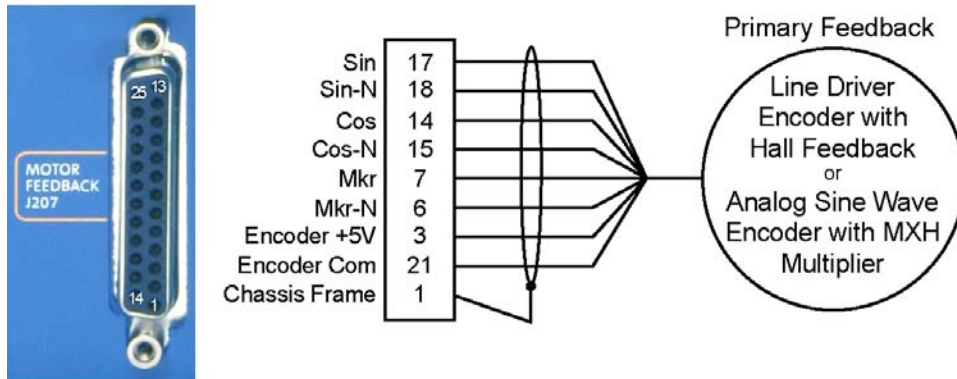

Optional J205 Secondary Encoder Channel

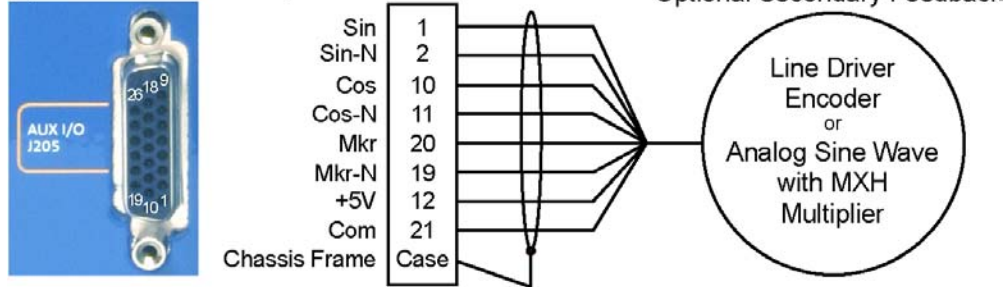

For full cable drawings, refer to your software CD ROM.

Figure 2-12. Encoder Feedback Connections

2.5.1. Encoder Phasing

Figure 2-13 illustrates the required encoder phasing for clockwise motor rotation, or positive forcer movement, through the stationary magnet track. If the motor is not visible, or maybe not be manually moved by hand, it maybe actively driven open loop, under program control, via the A3200\Programs\Samples\MsetDebug.Pgm. This program will move the motor in a positive direction, allowing the position of the encoder to be monitored in the Nstat.exe utility program. It will be displayed on the main Diagnostics tab as the "Pos Fdbk" item, as shown in Figure 2-14. The program should cause the encoder to produce a more positive position value as the program executes. If it indicates a more negative value, swap the connections to the controllers SIN and the SIN-N encoder inputs, or you may invert the sign of the CfgFbkVelMultiplier and CfgFbkPosMultiplier axis parameters. However, if this axis is configured for dual loop, two feedback devices, one for position and one for velocity feedback, invert only the one axis parameter associated with the incorrectly phased feedback device.

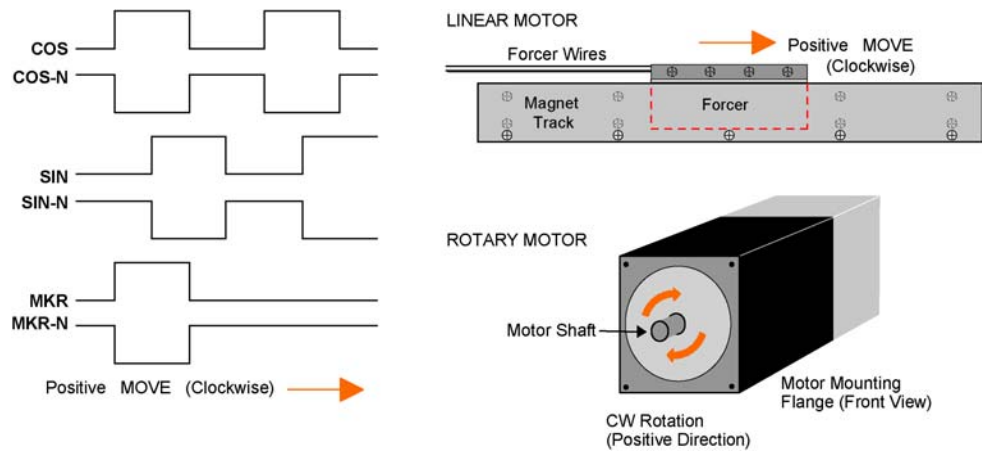

Figure 2-13. Encoder Phasing Reference Diagram

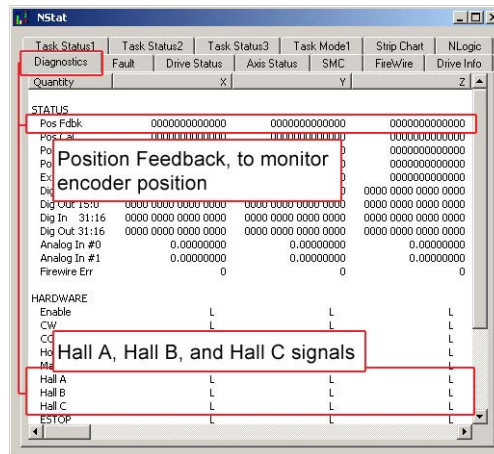
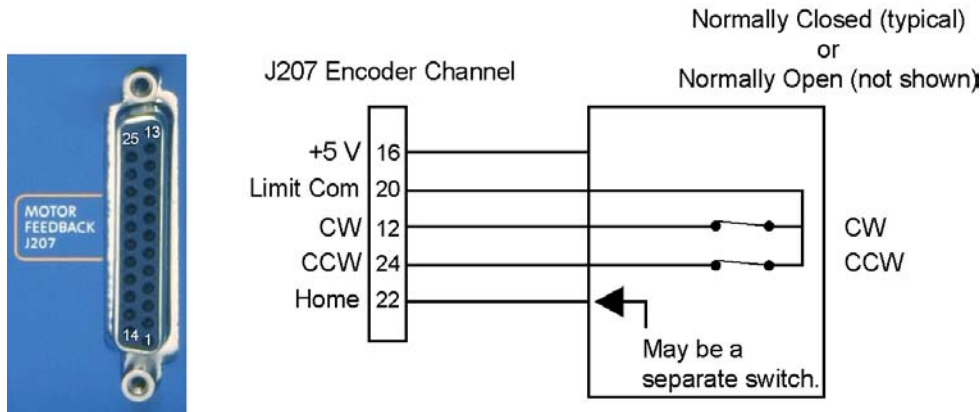

Figure 2-14. Encoder and Hall signals in the Nstat.exe Utility Program

2.6. End of Travel (EOT) Limit Input Connections

End of Travel (EOT) Limits are required to define the end of the physical travel. One of which may also be also used for homing the axis, which defines an absolute reference for the user coordinate system. EOT Limits are relative to positive motion, which is defined as clockwise rotary motion or positive linear motor motion. Positive or clockwise motion is stopped by the CW or clockwise EOT limit input, etc.



For full cable drawings, refer to your software CD ROM.

Figure 2-15. End of Travel Limit input Connections

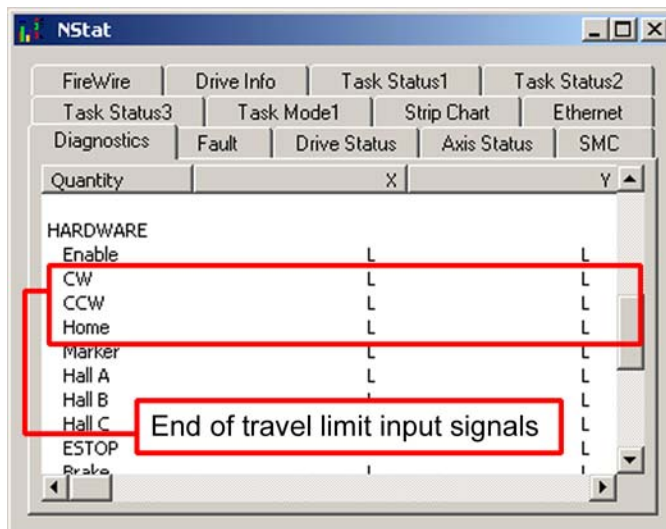
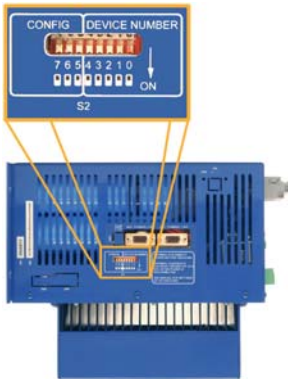

Figure 2-16. Limit Inputs in the Nstat Utility

2.6.1. End of Travel (EOT) Limit Phasing

If the EOT limits are reversed, swap the connections to the CW and CCW inputs at the J207 connector of the Ndrive HL. The logic level of the EOT limit inputs may be viewed on the Diagnostic tab of the Nstat utility, as shown in Figure 2-15.

2.7. Communication Channel Settings



Each Ndrive HL must have a unique communication channel number defined by switch S2. It is recommended that they be sequential beginning with the first device number. The 1st device as indicated by the switch settings in row 1 of the following table will be configured by the Axis 1 parameters in the Nparam utility. Assuming all axes are selected on the “Axis“ menu in Nparam, they will be the parameters in the first column. The Ndrive HL configured as Row 2 indicates below, will be configured by the axis parameters in column 2 of the Nparam utility, etc.

Information on connecting options such as analog and digital I/O, and laser firing (PSO) is provided in Chapter 4: Options.

Table 2-5. Ndrive HL Switch Settings (S2)

Ndrive HL #	Switch Settings (Off is indicated by “ - ”)							
	7	6	5	4	3	2	1	0
1 st	↓	↓	↓	↓	↓	↓	↓	↓
2 nd	↓	↓	↓	↓	↓	↓	↓	-
3 rd	↓	↓	↓	↓	↓	↓	-	↓
4 th	↓	↓	↓	↓	↓	↓	-	-
5 th	↓	↓	↓	↓	↓	-	↓	↓
6 th	↓	↓	↓	↓	↓	-	↓	-
7 th	↓	↓	↓	↓	↓	-	-	↓
8 th	↓	↓	↓	↓	↓	-	-	-
9 th	↓	↓	↓	↓	-	↓	↓	↓
10 th	↓	↓	↓	↓	-	↓	↓	-
11 th	↓	↓	↓	↓	-	↓	-	↓
12 th	↓	↓	↓	↓	-	↓	-	-
13 th	↓	↓	↓	↓	-	-	↓	↓
14 th	↓	↓	↓	↓	-	-	↓	-
15 th	↓	↓	↓	↓	-	-	-	↓
16 th	↓	↓	↓	↓	-	-	-	-
17 th	↓	↓	↓	-	↓	↓	↓	↓
18 th	↓	↓	↓	-	↓	↓	↓	-
19 th	↓	↓	↓	-	↓	↓	-	↓
20 th	↓	↓	↓	-	↓	↓	-	-
21 st	↓	↓	↓	-	↓	-	↓	↓
22 nd	↓	↓	↓	-	↓	-	↓	-
23 rd	↓	↓	↓	-	↓	-	-	↓
24 th	↓	↓	↓	-	↓	-	-	-
25 th	↓	↓	↓	-	-	↓	↓	↓
26 th	↓	↓	↓	-	-	↓	↓	-
27 th	↓	↓	↓	-	-	↓	-	↓
28 th	↓	↓	↓	-	-	↓	-	-
29 th	↓	↓	↓	-	-	-	↓	↓
30 th	↓	↓	↓	-	-	-	↓	-
31 st	↓	↓	↓	-	-	-	-	↓
32 nd	↓	↓	↓	-	-	-	-	-

2.8. Connecting Multiple Ndrive HLs

Following are two interconnection diagrams and a chart showing the part numbers of the FireWire Bus PCI card and the various interconnect cables and their part numbers.

Table 2-6. FireWire Card and Cable Part Numbers

Part Number	Description
NFire-PCI	FireWire OHCI compliant PCI interface card
NFire-Multi	FireWire card, with USB 2.0 and GigaBit Ethernet LAN
NFire-PCI-TI-LP	Low Profile OHCI compliant PCI FireWire card
NConnect-4500-66	FireWire cable, 4.5 M (15 feet) long, 6 pin to 6 pin
NConnect-1800-66	FireWire cable, 1.8 M (6 feet) long, 6 pin to 6 pin
NConnect-900-66	FireWire cable, 900 mm (3 feet) long, 6 pin to 6 pin
NConnect-381-66	FireWire cable, 381 mm (15 inches) long, 6 pin to 6 pin
NConnect-228-66	FireWire cable, 228 mm (9 inches) long, 6 pin to 6 pin

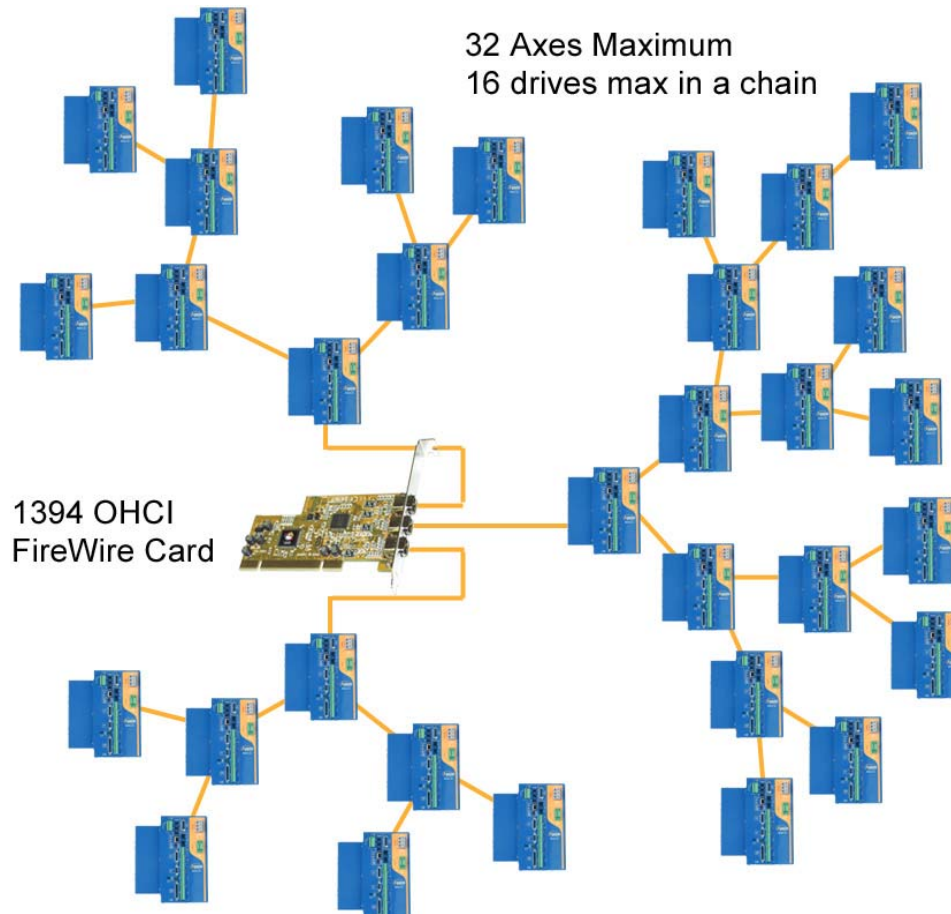

Figure 2-17. Recommended Star Daisy Chain Configuration

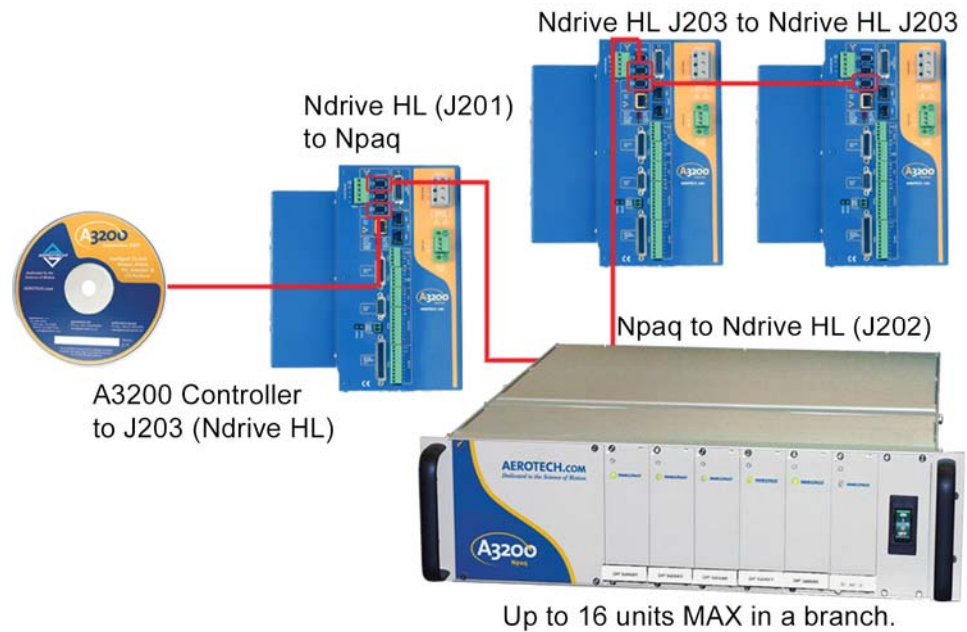

Figure 2-18. FireWire Daisy Chain



Before connecting any device to the FireWire bus, the device should be powered up and tested independently to prevent damaging interconnected drives.



Ndrive HLs, CPs, HPs, MPs, Nservos, Nsteps and Npaqs should always have their FireWire cables connected in a star configuration to minimize the FireWire cable lengths, see Figure 2-17.

2.9. PC Configuration and Operation Information

The Getting Started Guide (PN: EDU175), included with the Nmotion SMCs software package, provides a quick start guide with basic information. The Nview help included with the software provides additional information for configuring the Ndrive HL to the PC as well as information on hardware requirements, getting started, utilities and system operation, and on using the Nview HMI user application.



CHAPTER 3: TECHNICAL DETAILS

3.1. Auxiliary I/O Connector (J205)

The J205, Auxiliary I/O connector provides 1 analog and 6 digital inputs, 1 analog and 4 digital outputs and a secondary bi-directional RS-422 line driver encoder interface. See the following sub-sections for details on each type of signal within the J205 connector.



Table 3-1. Auxiliary I/O Connector Pin Assignment (J205)

Pin #	Label	Description	In/Out/Bi-dir.
1	Auxiliary Sine +	Secondary RS-422 Channel - Sine+	Bi-dir.
2	Auxiliary Sine -	Secondary RS-422 Channel - Sine-	Bi-dir.
3	In 12 +	Input 12 High Speed Opto. + (user interrupt)	Input
4	In 12 -	Input 12 High Speed Opto. - (user interrupt)	Input
5	In 13 +	Input 13 High Speed Opto. + (user interrupt)	Input
6	In 13 -	Input 13 High Speed Opto. - (user interrupt)	Input
7	Out 8	Output 8	Output
8	Out 9	Output 9	Output
9	Out 10	Output 10	Output
10	Auxiliary Cosine +	Secondary RS-422 Channel - Cosine+	Bi-dir.
11	Auxiliary Cosine -	Secondary RS-422 Channel - Cosine-	Bi-dir.
12	+5 Volt	+5 Volt (500 mA. max.)*	Output
13	Analog 0 In+	Analog Input 0 + (Differential)	Input
14	Analog 0 In-	Analog Input 0 - (Differential)	Input
15	Out Com	Output Common	-
16	Out 11	Output 11 / optional PSO Laser Firing Output	Output
17	In 8	Input 8	Input
18	In 9	Input 9	Input
19	Auxiliary Marker -	Secondary RS-422 Channel - Mrk+ / PSO out.	Bi-dir.
20	Auxiliary Marker +	Secondary RS-422 Channel - Mrk- / PSO out.	Bi-dir.
21	Common (+5 Volt)	Common (+5 Volt User Supply)	-
22	Analog 0 Out	Analog Output 0	Output
23	A Gnd	Analog Common	-
24	In Com	Input Common	-
25	In 10	Input 10	Input
26	In 11	Input 11	Input

* Total user +5 V power is limited to 500 mA, by an internal re-settable semiconductor fuse.

Table 3-2. Auxiliary I/O Mating Connector (J205)

26 Pin HD “D” style con.	Aerotech	Third Party Source
Connector	ECK01259	Kycon K86-AA-26P
Back shell	ECK00600	Cinch DA24658
Screw Locks, Qty. 2	EIZ00294	TRW D-20419-16

All of the external power provided by the Ndrive HL to the user is limited to 500 mAmps and protected by a re-settable semiconductor fuse. Should an over-current condition occur, the device will open to protect against the overload. To reset the over-current device, remove the overload condition.



Please note that the inputs and outputs on the Auxiliary connector (J205) begin with number 8, as shown in Table 3-1. Inputs and outputs 0 – 7 are present on the optional –IOPSO, see Chapter 4 for more information.

3.1.1. Secondary Encoder Channel (J205)

The encoder channel can be used as an input for master/slave operation (handwheel) or for dual feedback systems or for an encoder input/output for multi-axis laser firing (see Chapter 4 for more information). The EncoderDivider axis parameter configures the input/output state of this encoder channel. This interface may not be multiplied by the MXH option and must be a 5-volt RS-422 line driver encoder. It allows up to an 8 MHz encoder signal (31 nsec. minimum edge separation), producing 32 million counts per second, after times four (x4) quadrature decoding. The Auxiliary Marker output has a .02 us propagation delay typical, when used as the PSO firing output.

See Table 3-2 for the mating connector part number.



Table 3-3. Auxiliary Encoder Pin Assignment on Connector (J205)

Pin #	Label	Description	In/Out/Bi.
1	Auxiliary Sine +	Secondary RS-422 Channel - Sine+	Bi-directional
2	Auxiliary Sine -	Secondary RS-422 Channel - Sine-	Bi-directional
10	Auxiliary Cosine +	Secondary RS-422 Channel - Cosine+	Bi-directional
11	Auxiliary Cosine -	Secondary RS-422 Channel - Cosine-	Bi-directional
12	+5 Volt	+5 Volt (500mA. max.)*	Output
19	Auxiliary Marker -	Secondary RS-422 Channel - Mrk+ / PSO out.	Bi-directional
20	Auxiliary Marker +	Secondary RS-422 Channel - Mrk- / PSO out.	Bi-directional
21	Common (+5 Volt)	Common (+5 Volt User Supply)	-

* Total user +5 V power is limited to 500 mA, by an internal re-settable semiconductor fuse.

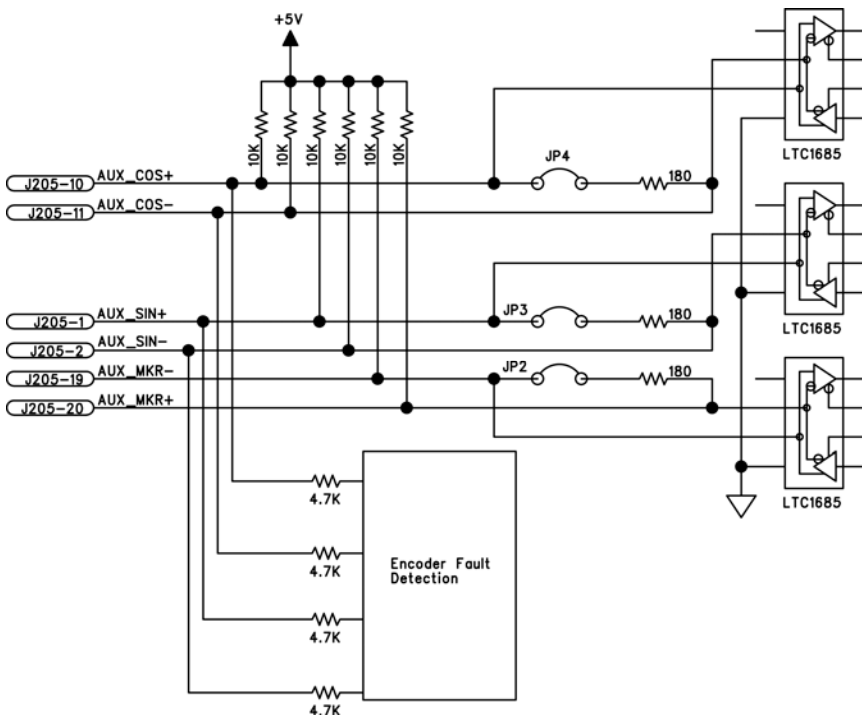

Figure 3-1. Secondary Encoder Channel (J205)



3.1.2. User Outputs 8-11 (J205)

All outputs (Figure 3-2) are rated for 40 volts DC and 80 mAmps per channel. Power dissipation may not exceed 90 mWatts per channel. Figure 4-10 illustrates how to connect to an output in current sinking mode.

Output 11, shown in Figure 3-2, may be defined as a low-speed PSO (Laser Firing output), however, it is only rated for a maximum output frequency of 1 kHz, with a typical propagation delay of 250 us. The auxiliary marker output on pins 19 and 20 of J205 (see Section 3.1) may be opto-isolated by the user and software configured as the PSO output via the EncoderDivider axis parameter and the PSOCONTROL command, see the Nview help for more information. See Section 3.2 for more information on the PSO option.

See Table 3-2 for the mating connector part number.

Table 3-4. User Outputs Pin Assignment on Connector (J205)

Pin #	Label	Description	In/Out/Bi.
7	Out 8	Output 8	Output
8	Out 9	Output 9	Output
9	Out 10	Output 10	Output
12	+5 Volt	+5 Volt (500mA. max.)*	Output
15	Out Com	Output Common	-
16	Out 11	Output 11 / optional PSO Laser Firing Output	Output
21	Common (+5 Volt)	Common (+5 Volt User Supply)	-

* Total user +5 V power is limited to 500 mA, by an internal re-settable semiconductor fuse.

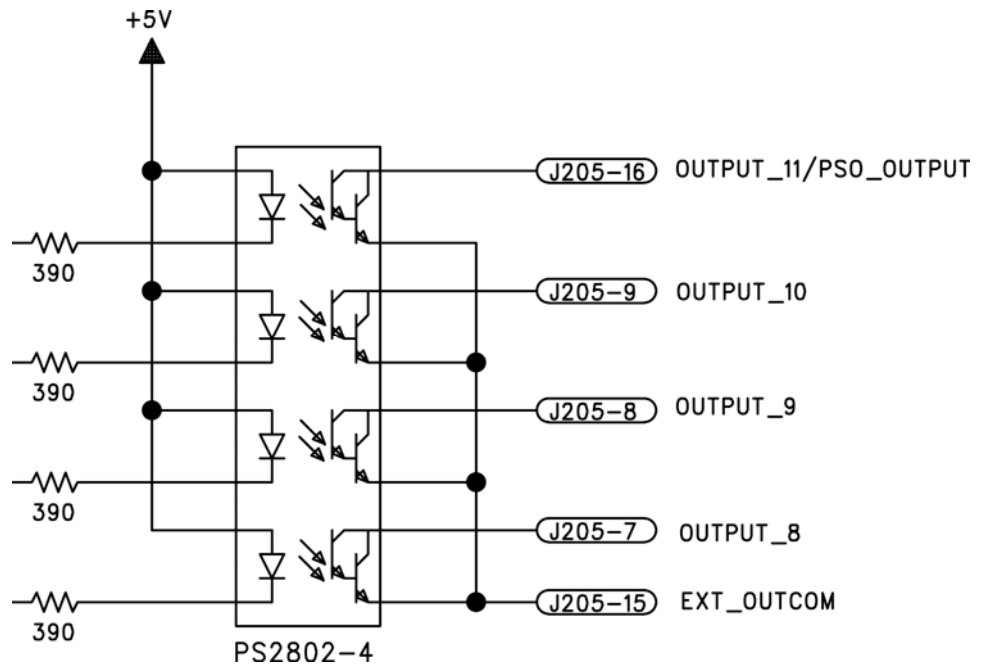

Figure 3-2. User Outputs (J205)

3.1.3. User Inputs 8-11 (J205)

All inputs (Figure 3-3), including the high-speed inputs, are scaled for an input voltage of 5-24 volts DC. A higher input voltage requires adding external series resistors to limit the current to 20 milliamps. Figure 4-10 and Figure 4-11 illustrate how to connect to an output in current sourcing and sinking current modes, respectively. Inputs 8-10 may also be used as CW, CCW and Home EOT limit inputs, respectively, by setting bit 22 of the DriveIOConfig axis parameter.

See Table 3-2 for the mating connector part number.



Table 3-5. User Inputs Pin Assignment on Connector (J205)

Pin #	Label	Description	In/Out/Bi.
12	+5 Volt	+5 Volt (500mA. max.)*	Output
17	In 8	Input 8 / CCW EOT Input	Input
18	In 9	Input 9 / CW EOT Input	Input
21	Common (+5 Volt)	Common (+5 Volt User Supply)	-
24	In Com	Input Common	-
25	In 10	Input 10 / Home Input	Input
26	In 11	Input 11	Input

* Total user +5 V power is limited to 500 mA, by an internal re-settable semiconductor fuse.

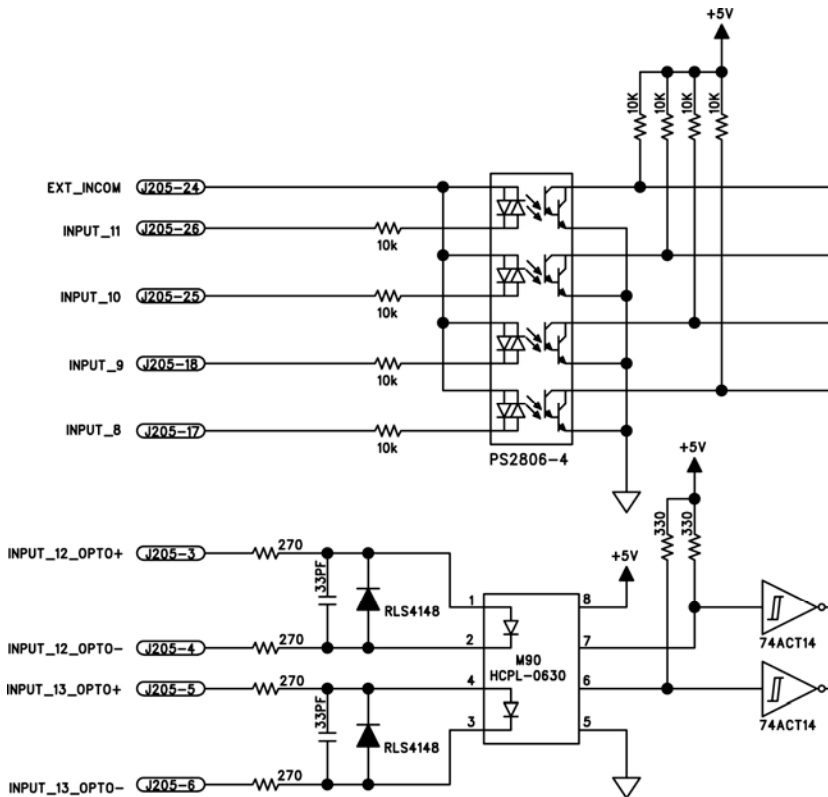

Figure 3-3. All User Inputs 8-13 (J205)



3.1.4. High Speed User Inputs 12-13 (J205)

All inputs (Figure 3-3), including the high-speed inputs, are scaled for an input voltage of 5-24 volts DC. A higher input voltage requires adding external series resistors to limit the current to 20 milliamps. The high-speed inputs (inputs 12 and 13) have a delay of 50 nanoseconds (typical).

See Table 3-2 for the mating connector part number.

Table 3-6. High Speed User Inputs Pin Assignment on Connector J205

Pin #	Label	Description	In/Out/Bi
3	In 12 +	Input 12 High Speed Opto. + (user interrupt)	Input
4	In 12 -	Input 12 High Speed Opto. - (user interrupt)	Input
5	In 13 +	Input 13 High Speed Opto. + (user interrupt)	Input
6	In 13 -	Input 13 High Speed Opto. - (user interrupt)	Input
12	+5 Volt	+5 Volt (500mA. max.)*	Output
21	Common (+5 V)	Common (+5 Volt User Supply)	-
24	In Com	Input Common	-

* Total user +5 V power is limited to 500 mA, by an internal re-settable semiconductor fuse.

3.1.5. Analog Input 0 (J205)

The analog inputs accept a signal within the range of -10 through +10 volts DC. Signals outside this range may damage the input. For analog input technical information, see Section 4.1.4.

Table 3-7. Auxiliary I/O Connector Pin Assignment (J205)

Pin #	Label	Description	In/Out/Bi.
13	Analog 0 In+	Analog Input 0 + (Differential)	Input
14	Analog 0 In-	Analog Input 0 - (Differential)	Input
23	A Gnd	Analog Common	-

* Total user +5 V power is limited to 500 mA, by an internal re-settable semiconductor fuse.

3.1.6. Analog Output 0 (J205)

The analog output may be programmed to output a signal within the range of -10 through +10 volts DC. For analog output technical information, see Section 4.1.2.

See Table 3-2 for the mating connector part number.

Table 3-8. Auxiliary I/O Connector Pin Assignment (J205)

Pin #	Label	Description	In/Out/Bi.
22	Analog 0 Out	Analog Output 0	Output
23	A Gnd	Analog Common	-

* Total user +5 V power is limited to 500 mA, by an internal re-settable semiconductor fuse.

3.2. Position Synchronized Output (PSO) / Laser Firing

The Ndrive HL includes a Position Synchronized Output (PSO or Laser Firing) option. This feature may be programmed to generate an output synchronized to axes positions, based upon a user-defined trigger condition, most typically, but not limited to firing a laser. The Ndrive HL offers three levels of laser firing, single axis (std.) and two and three axis. Trigger signals may be derived from the primary encoder channel, secondary encoder channel, either of the two optional SSI Net ports or a software trigger. Both SSI Net ports may provide axes encoder signals or marker signals to/from another Ndrive HL at a maximum of a 20 MHz. data rate (50 nsec. minimum edge separation). Single axis tracking is limited to a 20 MHz. data rate and multi-axis to a 5 MHz. tracking rate. The PSOTRACK command may be used to scale the encoder input signal to limit the maximum tracking rate. The synchronized output pulse is solely generated within sophisticated and versatile high-speed hardware, allowing minimal delays between the trigger condition and the output. Single axis PSO laser firing latency is 200 nanoseconds. –DUALPSO and –TRIPLEPSO laser firing latency is 275 nanoseconds, not including the propagation delay of the output device. Refer to Figure 3-6 for a basic single-axis block diagram of the PSO capabilities, or Figure 3-4 and Figure 3-5 for a more detailed block diagram of the multi-axis capabilities that also apply to single-axis firing. The output may be either an open-collector output (dedicated PSO output or user output 11) or a differential RS-422 output. The opto-isolated output is available in three different configurations as shown in Table 3-10. Additionally, the PSO options provide Data Capture and Data Update capabilities, also shown in Figure 3-4 and Figure 3-5. For programming information, refer to the Nview HMI Help.

Table 3-9. PSO Encoder Signal Sources and Pre-Scaling Methods

Encoder Signal Source	Max. Data Rate (w/o pre-scalar)	Encoder Input (pre-scalar)	Encoder Output (pre-scalar)
Primary Encoder	32 MHz.	PSOTRACK Command	CfgFbkEncQuadDivider axis parameter (MXH only)
Secondary Encoder	32 MHz.	PSOTRACK Command	None
SSI Net Ports 1 and 2	20 MHz.	PSOTRACK Command	CfgFbkEncMxhSetup axis parameter

Table 3-10. PSO Output Sources

PSO Output Type	Maximum Frequency	Standard or Option	Requires User Isolation
High Speed Opto-Isolator (J301)	Table 4-13	-IOPSO option	No
Opto-Isolated Output 11 (J205)	1 kHz	Standard	No
RS-422 Marker output on Sec. Encoder (J205)	10 MHz	Standard	Yes

The pre-scalar in the block diagram is used to normalize the resolution of axes with different machine step sizes or to scale down (divide) the maximum input frequency to the PSO tracking hardware. The PSO hardware operates in machine counts, so all axes must be scaled, or normalized to like units. This allows a trigger to be generated from a true vectorial position change. Each of the three possible tracking channels has a pre-scalar, which may be used to divide the number of encoder counts on that channel. Each pre-scalar defaults to 1 and may divide the input feedback pulses by up to 1,023.

The trigger condition may be a software trigger under program control, various other hardware triggers, or most typically a user-defined change in vectorial position, on one to three axes. This vectorial position change is monitored via hardware, allowing an output pulse to be generated in less than 275 nanoseconds (200 nsec. for single axis) after the trigger is detected, not including the propagation delay of the output device. This is accomplished via hardware that monitors the designated axes positions, calculates the sum of the squares of the axes positions and compares it to the desired (squared) position trigger value. All of the mathematical squaring of the positions occurs in hardware for speed. The comparison of the squared command to feedback position occurs at an 8 MHz. rate for multi-axis firing and at a 20 MHz. rate for single axis firing. Furthermore, this vectorial position trigger value is queued via a 255 level queue, in hardware to the triggering hardware, with each trigger advancing through the queue to the next trigger value. This allows the trigger value to be specified as a series of incremental trigger points, if desired.

The absolute accuracy is excellent, although, point-to-point accuracy may vary, due to the calculated feedback squared firing distance jumping past the (internally squared) user programmed firing distance. This small error is accumulated and subtracted from the next firing distance, maintaining absolute accuracy. For example, if the user programs a trigger to occur after a vectorial change in position of 5 machine steps. Internally, this is squared, and the axes positions are internally squared and compared to 25. If they are equal to or greater than 25, a trigger event occurs. The comparison occurs at an 8 MHz. rate (125 nano-seconds), so, should the sum of the square of the axes change in position be equal to 9 during a sample period, no trigger occurs. However, on the next sample, the sum of the squares of the axes positions could now be equal to 36. A trigger event would now occur (36 is greater than 25) and the remainder (11) is then stored to be summed with the squared feedback positions during the next sample period.

The output pulse is also user programmable. It may be a single, or multiple pulses per trigger event. It too is generated in hardware and fed from a 255 level queue, allowing trigger events to advance through the queue, varying the output pulse per trigger event.

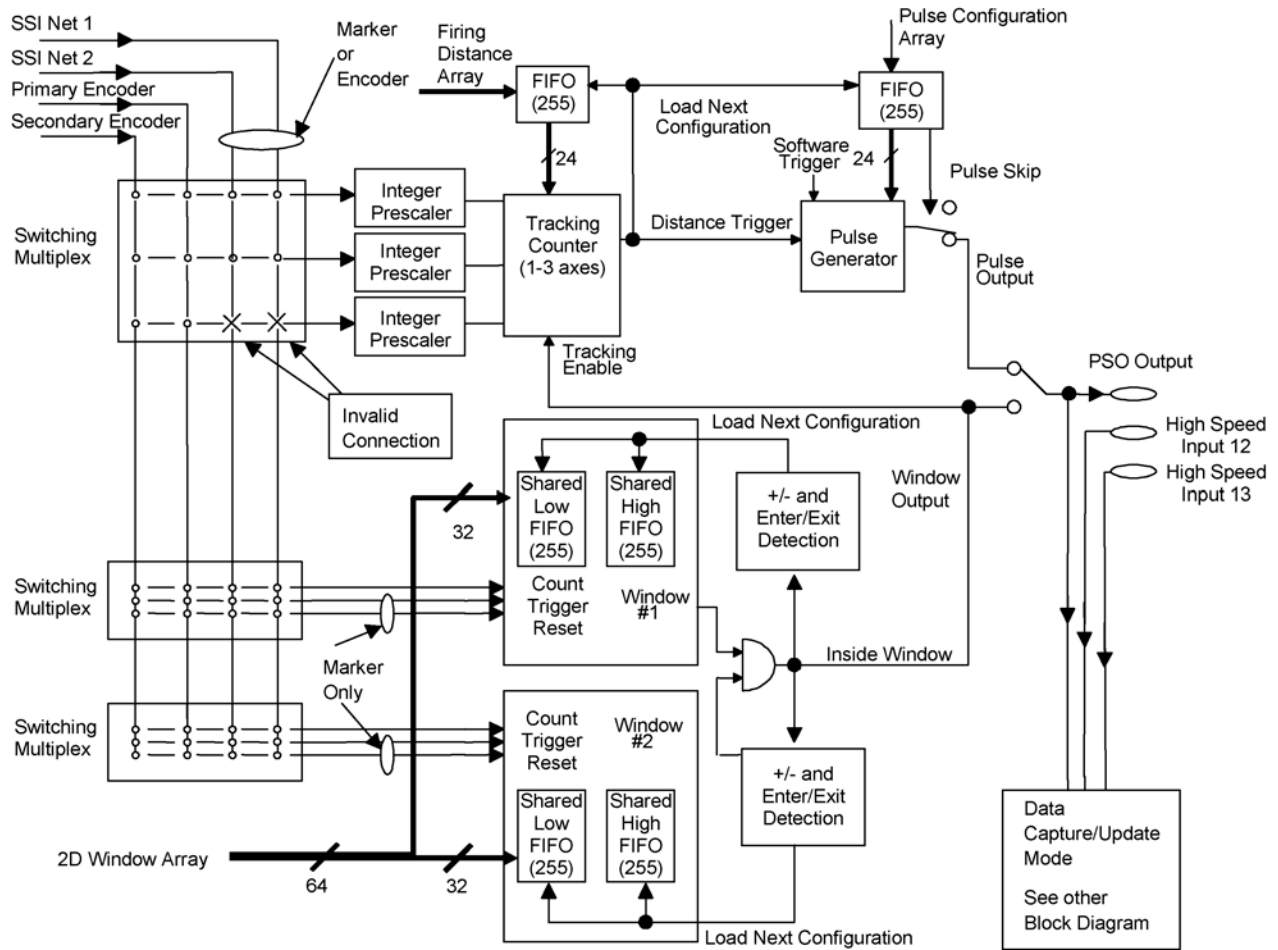

Figure 3-4. Advanced 1 - 3 Axis Firing

The window modes allow firing to occur, or be enabled, based upon axes being within a user-defined window. This window may be one or two-dimensional. The ± and Enter/Exit Detection block within the block diagram is used to prevent false triggering due to one bit dither on an axis, etc. Window modes may not be pre-scaled as indicated in the block diagram.

The Data Capture and Data Update modes allow data to be captured or written to the I/O on the occurrence of the internal or external trigger. Data Capture mode allows position, digital inputs, etc. to be captured. Data Update mode allows analog or digital outputs to be set by the same trigger. The capture and update modes are defined in Figure 3-5. For a full description of these modes, refer to the Nview HMI help.

These Capture/Update modes, share four FIFO's (queue's) with Window 1 and Window 2, preventing the window-firing modes from being used with the Capture/Update mode. Using a queue from a window, precludes using that window (1 or 2) for firing, however, queues from window 1 may be used for data capture/update mode, while queues from window 2 may be used for window firing purposes. The Capture/Update modes vary for Window 1 and Window 2, see Figure 3-5.

The data capture mode rate for analog inputs is limited to approximately 100,000 samples per second due to A/D conversion rate. The data update mode for analog outputs is limited to 500,000 Hertz due to internal serial bus design constraints.

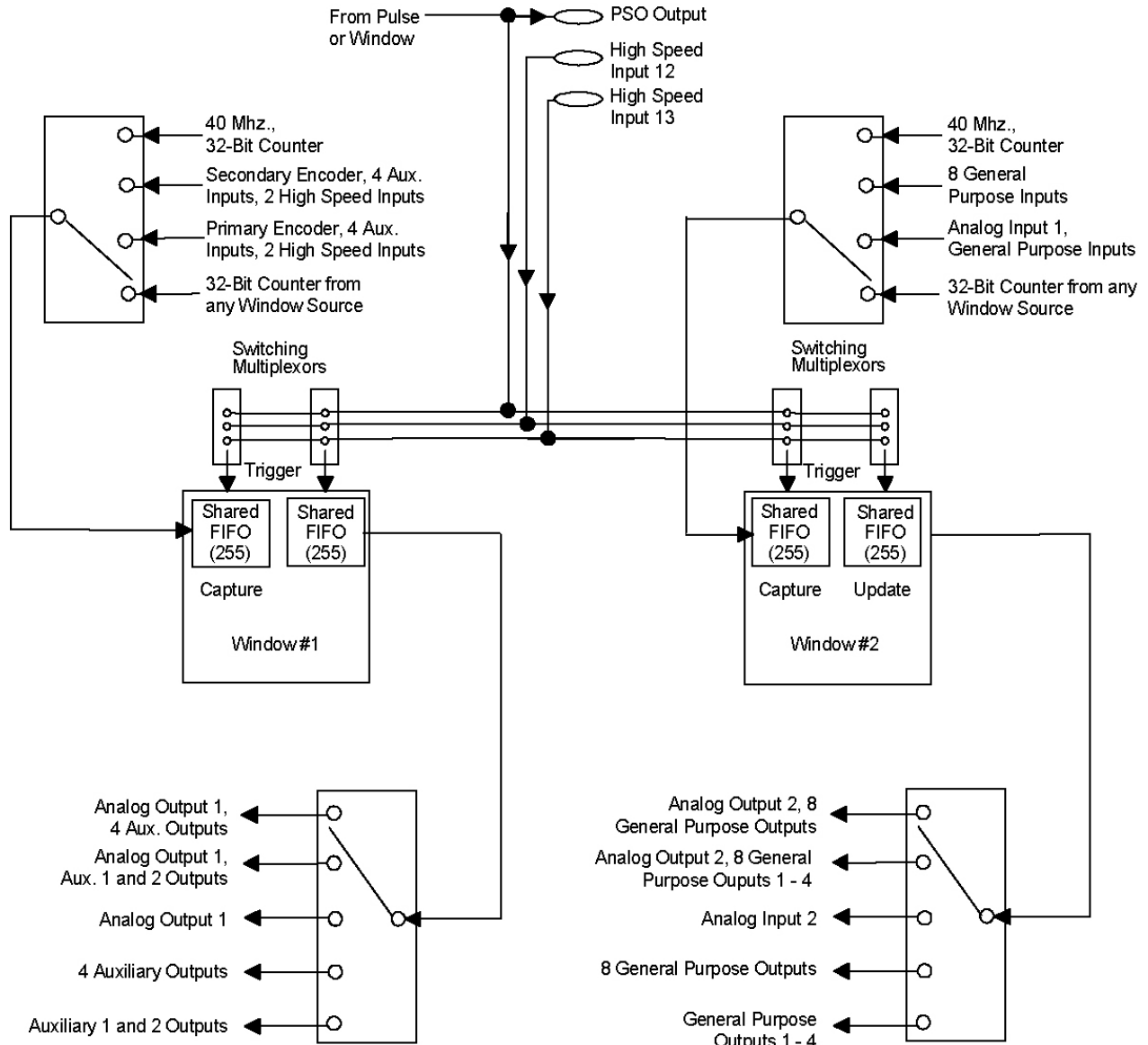

Figure 3-5. Data Capture/Data Update Modes

3.2.1. Single Axis Laser Firing

Single axis firing requires no additional encoder signals and is capable of tracking the axis position at up to a 20 MHz. tracking rate (50 nsec. minimum edge separation). It may be programmed to fire from any available encoder source, see Table 3-9. Single axis firing provides one feature not present with the multi-axes firing option, it allows for directional based firing. This means that you may program a firing distances for the positive and negative motion separately. Single axis window firing and Capture/Update modes may be used with single-axis firing, limited only by the use of the Windows internal shared queue's.

See Figure 3-6 for a basic single-axis block diagram of the PSO capabilities or Figure 3-4 and Figure 3-5 for a more detailed block diagram of the multi-axis capabilities that also apply to single-axis firing.

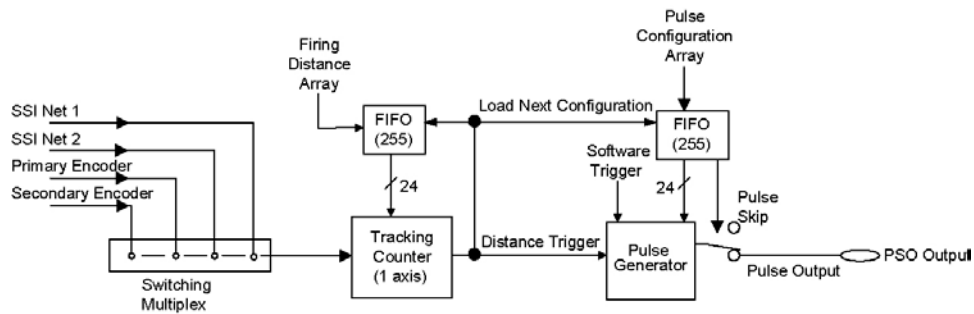

Figure 3-6. PSO Diagram – Basic Single Axis Firing

3.3. Motor Feedback (J207)



The 25-pin “D” style connector contains all of the required feedback inputs for a servo loop. This connector has inputs for a 3-channel encoder, three limit switches, and three Hall effect devices. Each of these inputs provides feedback for the DSP microprocessor controlled position, velocity and current loops.

See Section 2.5.1. for information on interfacing non-Aerotech motors.

Table 3-11. Motor Feedback Connector Pin Assignment (J207)

Pin #	Label	Description	In/Out/Bi.
1	Frame	Chassis Frame	N/A
2	Thermistor	Motor over temperature Thermistor	Input
3	+5 Volt	+5 Volt Power for Encoder (500mA. max.)*	Output
4	Common	Signal Common	N/A
5	Hall B	Hall Effect Sensor B (Brushless Motors only)	Input
6	Mkr-	Encoder Marker Reference Pulse -	Input
7	Mkr+	Encoder Marker Reference Pulse +	Input
8	N.C.	No Connection	N/A
9	N.C.	No Connection	N/A
10	Hall A	Hall Effect Sensor A (Brushless Motors only)	Input
11	Hall C	Hall Effect Sensor C (Brushless Motors only)	Input
12	CW/+Lmt.	Clockwise End of travel limit	Input
13	Brake -	Optional Brake - Output	Output
14	Cos+	Encoder Cosine +	Input
15	Cos-	Encoder Cosine -	Input
16	+5 Volt	+5V Power for Limit Switches (500mA. max.)*	Output
17	Sin+	Encoder Sine +	Input
18	Sin-	Encoder Sine -	Input
19	N.C.	No Connection	N/A
20	Common	Signal Common for Limit Switches	N/A
21	Common	Signal Common for Encoder	N/A
22	Hm.Lmt.	Home Switch Input	Input
23	N.C.	No Connection	N/A
24	CCW/-Lmt.	Counterclockwise End of travel limit	Input
25	Brake +	Optional Brake + Output	Output

* Total user +5 V power is limited to 500 mA, by an internal re-settable semiconductor fuse.

Table 3-12. Motor Feedback Mating Connector (J207)

25-Pin Male D-style	Aerotech	Third Party Source
Connector	ECK00101	Cinch P/N DB25P
Back shell	ECK00656	Amphenol P/N 17-1726-2

All of the external power provided by the Ndrive HL to the user is limited to 500 mAmps and protected by a re-settable semiconductor fuse. Should an over-current condition occur, the device will open to protect against the overload. To reset the over-current device, remove the overload condition.

3.3.1. End of Travel Limit Inputs

Two of the three limit inputs are end-of-travel sensing (CW Limit and CCW Limit) while the third is a reference limit (Home Limit). All of the end-of-travel limit inputs accept 5-24 volt DC logic signals. The pin assignment for the connector is shown in the table below.

Alternatively, opto-isolated user inputs 8-10 may be used as the end-of-travel limit inputs, see Section 3.1.3.

See Table 3-12 for the mating connector part number.



Table 3-13. End of Travel Limit Inputs Pin Assignment on Connector J207

Pin #	Label	Description	In/Out/Bi.
12	CW/+Lmt.	Clockwise End of travel limit	Input
16	+5 Volt	+5 Volt Power for Limit Switches (500mA max.)*	Output
20	Common	Signal Common for Limit Switches	N/A
22	Hm.Lmt.	Home Switch Input	Input
24	CCW/-Lmt.	Counterclockwise End of travel limit	Input

* Total user +5 V power is limited to 500 mA, by an internal re-settable semiconductor fuse.

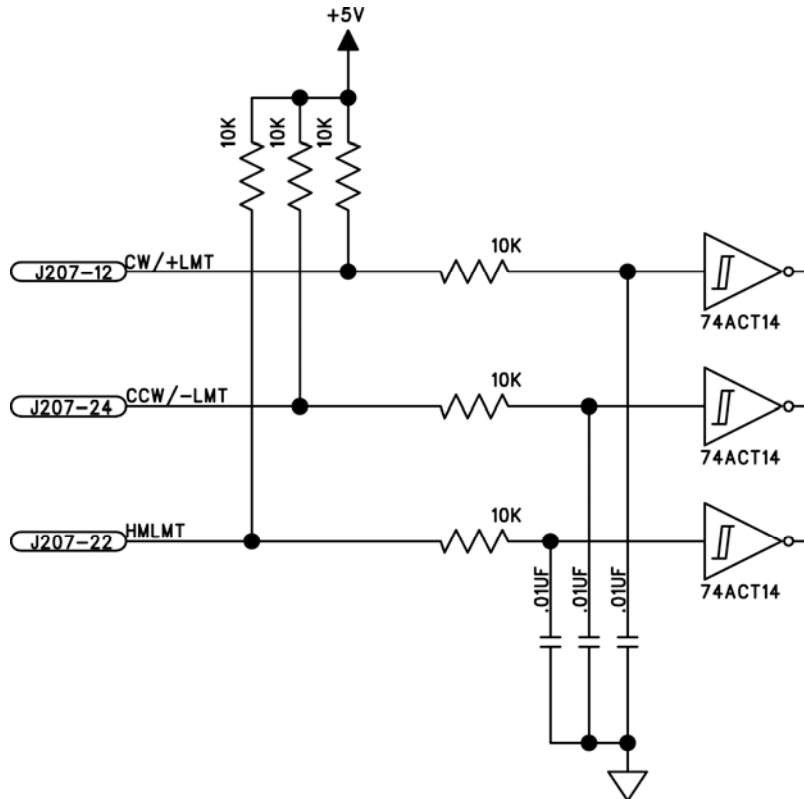

Figure 3-7. End of Travel Limit Inputs

3.3.2. Hall-Effect and Thermistor Inputs



The Hall-Effect switch inputs are highly recommended for AC brushless motor commutation but not absolutely required, see the Nview help for more information on axis configuration. The Hall-effect inputs accept 5-24 volt DC logic signals. The pin assignment for the connector is shown in the table below.

The thermistor input is used to detect an over temperature condition in a motor, via a positive temperature coefficient device. That is, as the temperature of the device increases, so does the resistance of the device. Under normal operating conditions, the resistance of the thermistor is low (i.e., 100 ohms). This will be seen as a low input signal. After the temperature causes the thermistor's resistance to increase above 1K ohms, the signal will be seen as a logic high, triggering an over temperature fault.

See Table 3-12 for the mating connector part number.

Table 3-14. Hall-Effect Inputs Pin Assignment on Connector J207

Pin #	Label	Description	In/Out/Bi.
2	Thermistor	Motor over temperature Thermistor	Input
3	+5 Volt	+5 Volt Power for Encoder (500mA. max.)*	Output
5	Hall B	Hall Effect Sensor B (Brushless Motors only)	Input
10	Hall A	Hall Effect Sensor A (Brushless Motors only)	Input
11	Hall C	Hall Effect Sensor C (Brushless Motors only)	Input
21	Common	Signal Common for Encoder	N/A

* Total user +5 V power is limited to 500 mA, by an internal re-settable semiconductor fuse.

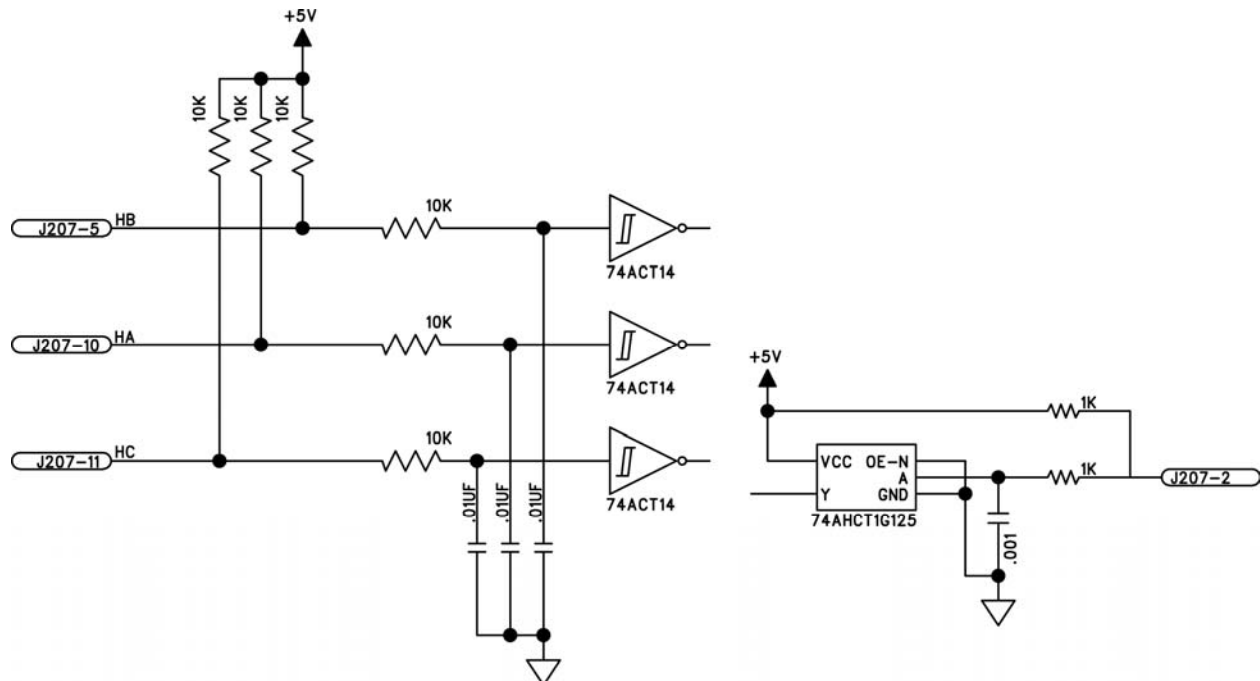

Figure 3-8. Hall-Effect and Thermistor Inputs (J207)

3.3.3. Brake Output

The brake output provides a direct connection to the brake the relay on the optional –IOPSO board. The brake output will be present on this connector only when the –IOPSO option board is present, allowing the brake signal to utilize the existing feedback cable without the need for additional wiring. See Section 4.1.3. in Chapter 4, for more hardware information on the brake output. The brake output may be automatically controlled via the drive, when activated via the BrakeOnDriveDisable axis parameter, or manually toggled via the BRAKE command, see the NView help for more information.

See Table 3-12 for the mating connector part number.

Table 3-15. Brake Output Pin Assignment on Connector J207

Pin #	Label	Description	In/Out/Bi.
13	Brake -	Optional Brake Relay - Output	Output
25	Brake +	Optional Brake Relay + Output	Output



3.3.4. Encoder Interface

The three encoder signals consists of the following: sine (Sin), cosine (Cos), and marker (Mkr) as well as their complimentary signals: sine-n (Sin-N), cosine-n (Cos-N), and marker-n (Mkr-N).

The encoder interface accepts an RS-422 differential quadrature signal in the range of 0 to 5 Volts DC in line driver format (Section 3.3.4.1). It allows up to an 8 MHz encoder signal (31 nsec minimum edge separation), producing 32 million counts per second, after times four (x4) quadrature decoding.

The encoder interface may be factory configured to accept an analog signal for the MXH (Section 3.3.4.5).

See Section 2.5.1. Encoder Phasing for information on interfacing non-Aerotech motors. See Table 3-12 for the mating connector part number.

Table 3-16. Motor Feedback Connector Pin Assignment (J207)

Pin #	Label	Description	In/Out/Bi.
1	Frame	Chassis Frame	N/A
3	+5 Volt	+5 Volt Power for Encoder (500mA. max.)*	Output
6	Mkr -	Encoder Marker Reference Pulse -	Input
7	Mkr +	Encoder Marker Reference Pulse +	Input
14	Cos +	Encoder Cosine +	Input
15	Cos -	Encoder Cosine -	Input
17	Sin +	Encoder Sine +	Input
18	Sin -	Encoder Sine -	Input
21	Common	Signal Common for Encoder	N/A

* Total user +5 V power is limited to 500 mA, by an internal re-settable semiconductor fuse.

All external power provided by the Ndrive HL to the user is protected by a re-settable semiconductor fuse. Should an over-current condition occur, the device will open to provide protection against the overload. To reset the over-current device, remove the over-current condition.

3.3.4.1. Line Driver Encoder (Standard)

The primary encoder input is standardly configured for a differential line driver encoder, in the range of 0 to +5 volts. It allows up to an 8 MHz encoder signal (31 nsec minimum edge separation), producing 32 million counts per second, after times four (x4) quadrature decoding. An analog encoder is used with the MXH option; see Figure 3-10 for more information.

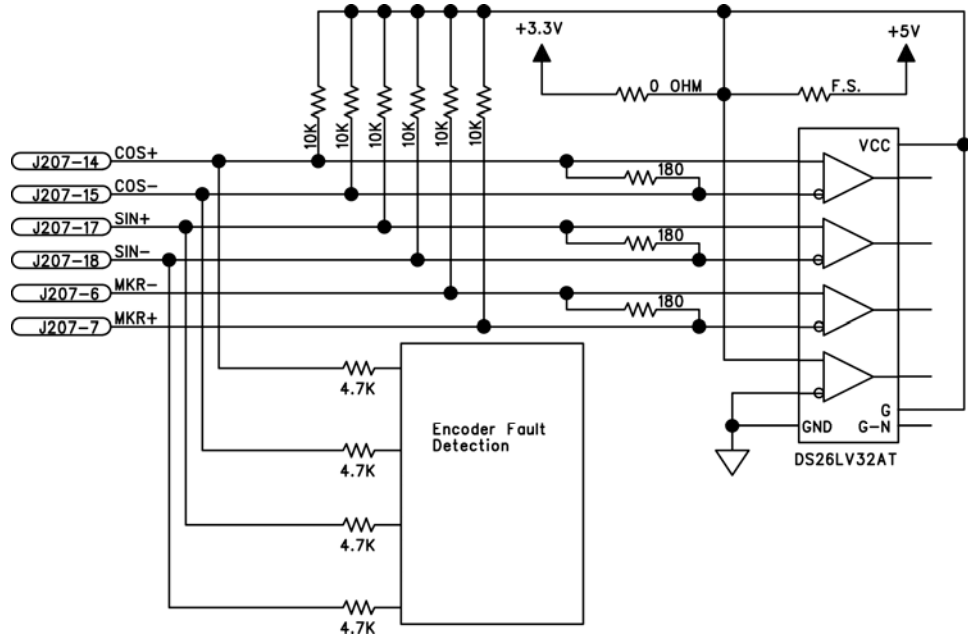

Figure 3-9. Line Driver Encoder Interface – Standard (J207)



The Ndrive HL is factory configured for either a square wave differential encoder (default), OR an analog encoder (MXH options).

3.3.4.2. MXH Option

The MXH encoder input options are defined for a differential analog encoder in the range of 0 to +5 volts. The maximum encoder input frequency is limited to 200 kHz, or less if the encoder signals are to be output via the SSI Net, see Table 3-17. The MXH multiplies the resolution up to 512 times, in addition to the controller’s x4 multiplication, providing a maximum of x 2048 multiplication (8.388607 GHz. Effective data rate), as shown in the first two columns of Table 3-17.

The MXH multiplication factor is determined by the CfgFbkEncMultFactorMXH axis parameter, which is then multiplied x4 additionally by the controller. Each time this axis parameter is changed, the controller will internally re-program its logic. This re-programming cycle will take about 3.5 minutes. The LED’s will indicate that the internal MXH option is being internally erased and then re-programmed, and that the axis may not be enabled during this time. While the –MXH option is being erased, the LED’s will indicate the pattern shown to the upper right. When the –MXH option is being re-programmed, the LED’s will alternate between the two patterns shown to the lower right.

The Ndrive HL contains digital potentiometers to adjust the gain, offset and phase balance of the analog Sine and Cosine inputs. The digital potentiometer settings are controlled by the CfgFbkEncCosGain, CfgFbkEncCosOffset, CfgFbkEncPhase, CfgFbkEncSineGain, CfgFbkEncSineOffset axis parameters. The –MXH option is compatible with the –DUALPSO and –TRIPLEPSO options. A differential line driver encoder may be used also, see Figure 3-9 for more information.

The specifications for the –MXH multiplier option are shown in Table 3-17. The following table indicates the maximum specifications for the MXH option when the signals are output via the SSI Net. Otherwise, the only limit is the maximum input frequency of 200 kHz. See Figure 3-9 for MXH typical input circuitry. The pin assignment is indicated in Table 3-11.



MXH Erase Cycle



MXH Programming Cycle



Alternate Flashing Pattern

Table 3-17. MXH Option Specifications

CfgFbkEncMult-FactorMXH Axis Parameter	Total Multiplication ^(1,2)	Applicable only when signals are output via the SSI Net ⁽⁴⁾			
		Clock ⁽³⁾ Freq. (MHz)	Max Input Freq (kHz)	Min Edge Separation (μs)	Min Pulse Width (μs)
10	X40	40	200	.025	.025
		20	200	.05	.05
		10	200	.1	.1
		5	125	.2	.2
50	X200	40	200	.025	.025
		20	100	.05	.05
		10	50	.1	.1
		5	25	.2	.2
100	X400	40	100	.025	.025
		20	50	.05	.05
		10	25	.1	.1
		5	12.5	.2	.2
200	X800	40	50	.025	.025
		20	25	.05	.05
		10	12.5	.1	.1
		5	6.25	.2	.2
250	X1000	40	40	.025	.025
		20	20	.05	.05
		10	10	.1	.1
		5	5	.2	.2
500	X2000	40	20	.025	.025
		20	10	.05	.05
		10	5	.1	.1
		5	2.5	.2	.2

1. Interpolation includes x4 from quadrature – i.e., MXH50 has a net interpolation of x200 (x50 from MXH and x4 from quadrature).
2. Configurable via the CfgFbkEncMultFactorMXH axis parameter from 1 to 512 in increments of 1.0, yielding a multiplication from x4 to x2048.
3. Defined by the CfgFbkEncMxhSetup axis parameter, for SSI Net use. Must be limited to 20 Mhz. for PSO tracking applications via the CfgFbkEncQuadDivider axis parameter.
4. Absolute maximum input frequency limited to 200 kHz due to 1.25 MHz sample rate, lesser limit applies only when signals are output via the SSI Net.

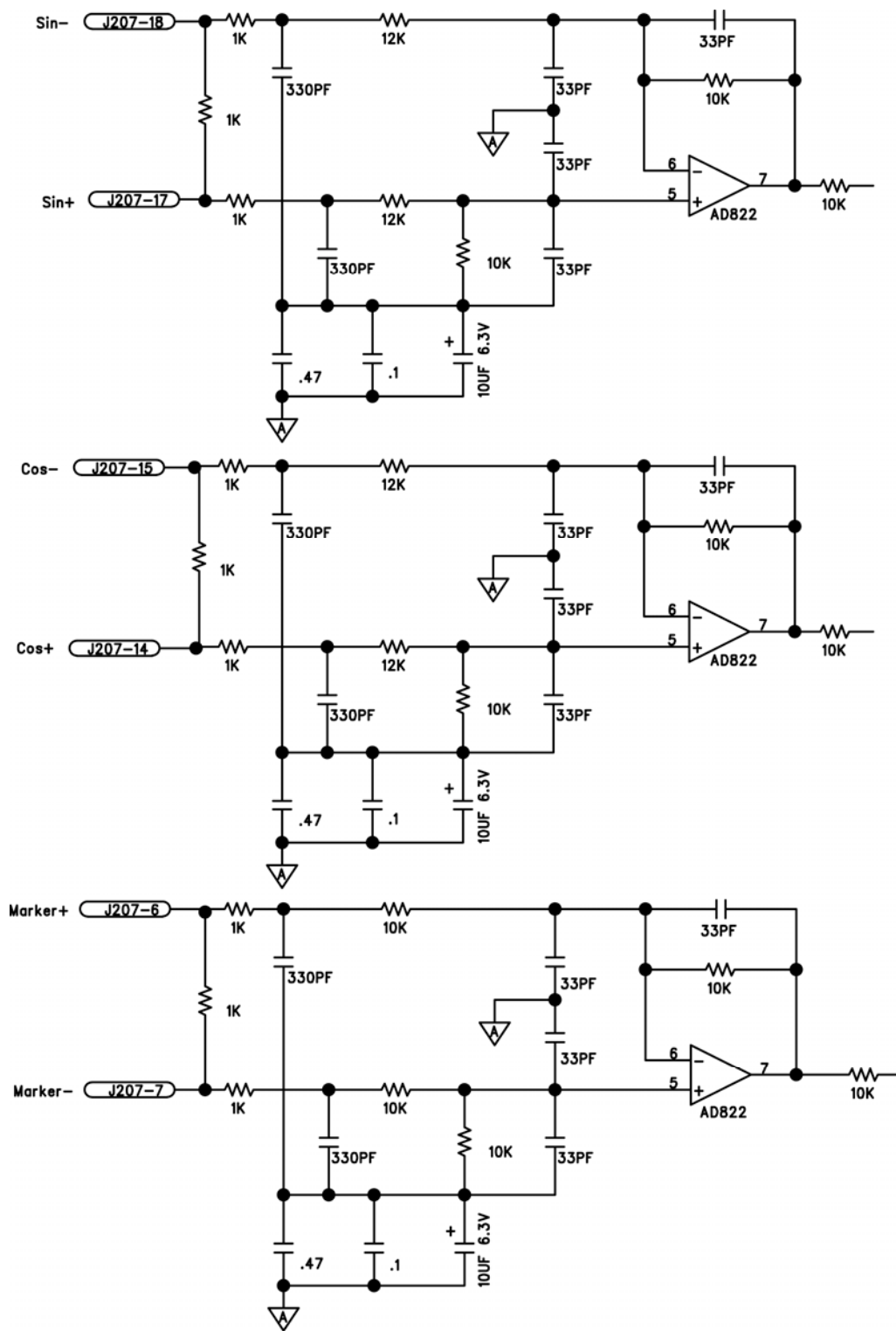

Figure 3-10. Optional MXH Analog Encoder Interface (J207)

3.4. RS-232 / RS-422 Port (J206)



Note that the RS-232C and RS-422 (factory option) ports may not be used simultaneously, as they are one physical port, converted to each interface by the appropriate line driver/receiver, as shown in Figure 3-11. Connecting the RS-232 port to a user’s PC requires only a standard 9-pin RS-232C interconnection cable (not a null modem). Currently, the RS-232C port serves only as a secondary means to upgrade the firmware in the Ndrive HL, which is done primarily through the FireWire port.

Table 3-18. J206 RS-232 / RS-422 Connector Pin Assignment

Pin #	Label	Description	In/Out/Bi.
1	Frame	Chassis Frame	N/A
2	RS-232 TXD	RS-232 Transmit Output	Output
3	RS-232 RXD	RS-232 Receive Input	Input
4	RS-422 TXD+	RS-422 Transmit Output +	Output
5	Common	Signal Common	N/A
6	RS-422 TXD-	RS-422 Transmit Output -	Output
7	RS-422 RXD+	RS-422 Receive Input +	Input
8	RS-422 RXD-	RS-422 Receive Input -	Input
9	+5 Volt	+5 Volt Power Output *	Output

* Total user +5 V power is limited to 500 mA, by an internal re-settable semiconductor fuse.

Table 3-19. RS-232 / RS-422 Port Mating Connector (J206)

9-Pin male D-style con.	Aerotech	Third Party Source
Connector	ECK00137	Cinch DE-9P
Back shell	ECK01021	Amphenol 17-1724-2

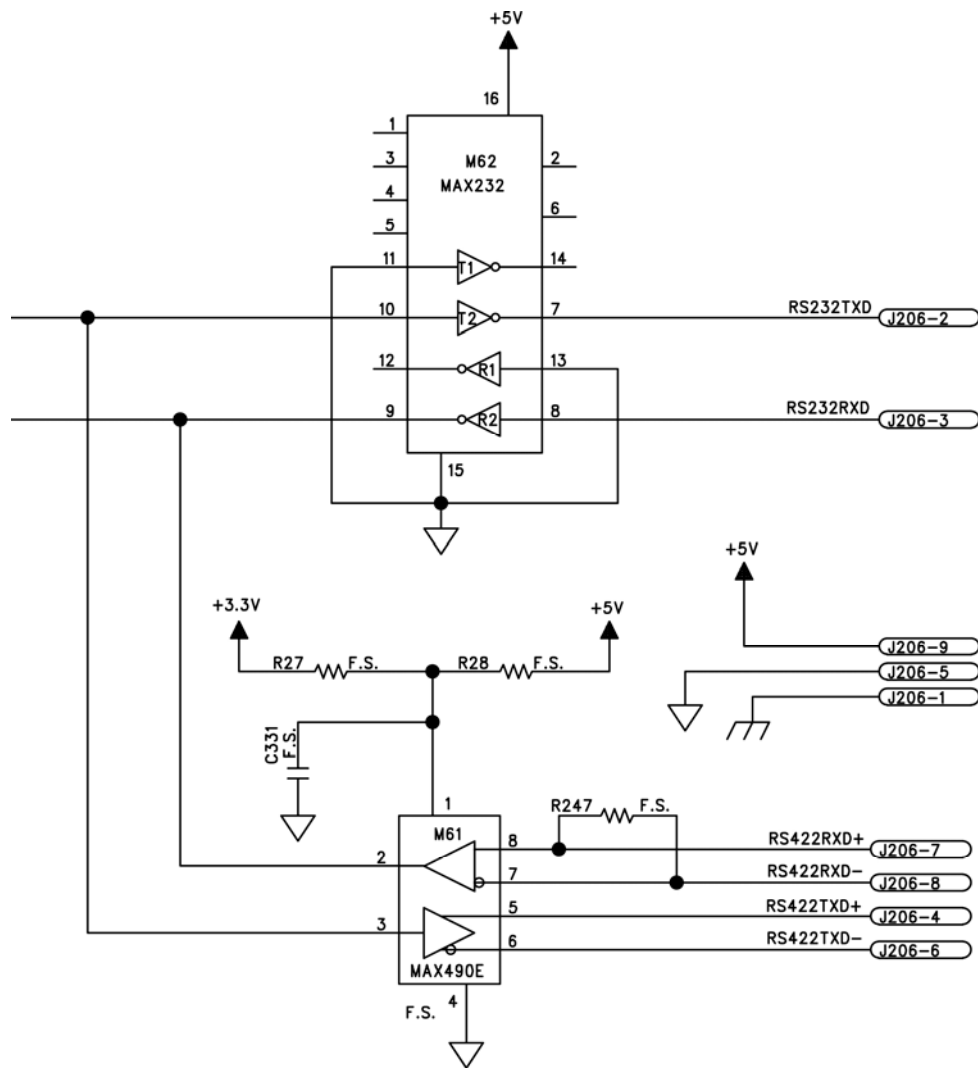
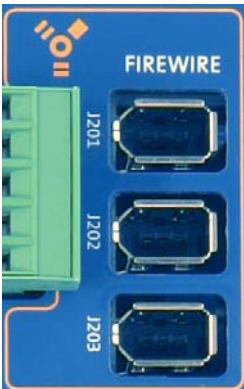

Figure 3-11. RS-232/RS-422 Connector (J206)

3.5. FireWire Bus (J201, J202, J203)



The FireWire bus is the high-speed communications media to the Ndrive HL, operating at 400 megabits per second. All command and configuration information is sent via the FireWire. All three ports are effectively in parallel, allowing any port to be used when daisy-chaining the Ndrive HLs together or with other devices such as the Ndrive CP, HP, Nstep, Nservo or Npaq. The FireWire bus power is independent of the Ndrive HL power. Should a drive fail, communication will be maintained with the other devices.

Table 3-20. J201, J202, J203 FireWire Connector Pin Assignment

Pin #	Label	Description	In/Out/Bi.
1	Bus Power	FireWire Adapter Power	In/Out
2	Physical Ground	FireWire Common (Isolated from Signal Common)	N/A
3 *	TPB# –	Port # Communication Signal	Bi-directional
4 *	TPB# +	Port # Communication Signal	Bi-directional
5 *	TPA# –	Port # Communication Signal	Bi-directional
6 *	TPA# +	Port # Communication Signal	Bi-directional
7	Frame	Chassis Frame	N/A
8	Frame	Chassis Frame	N/A
9	Frame	Chassis Frame	N/A

* Port 0, 1, and 2, respectively, as represented in the table by a “#”.

Pin 1 of the FireWire connector’s J201-J203, the power pin, are protected by a re-settable semiconductor fuse. If an over-current condition occurs, the device will open to protect against the overload. To reset the over-current device, remove the overload condition.

3.6. Voltage-to-Current Mode Operation

The firmware (version 2.06 and later) on the Ndrive HL supports a voltage-to-current mode. This mode allows the unit to run in a standalone mode, attached to a master position/velocity loop controller.

The standard operating mode of the Ndrive HL uses an OHCI IEEE-1394 connection from a host PC running the Nmotion SMC (software motion controller) to control servos. This connection is required for proper operation in this mode, since the fire wire connection provides positioning and synchronization information to the drive.

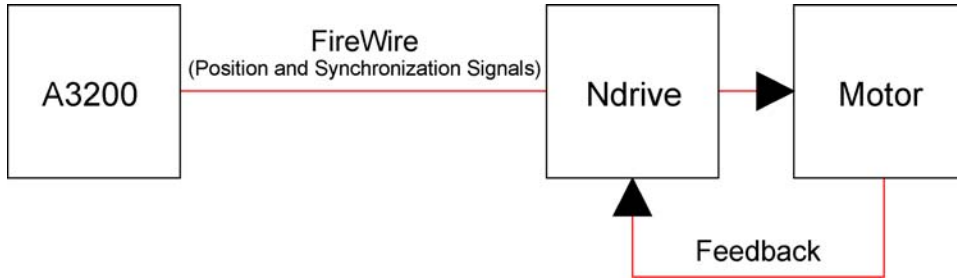

Figure 3-12. Normal Operation

The Voltage-to-Current mode of the Ndrive HL allows for a connection to a host controller that outputs $\pm 10V$ DC as a torque (current) command. In this mode, a connection to the fire wire is not required (synchronization is performed internally), except for parameter configuration.

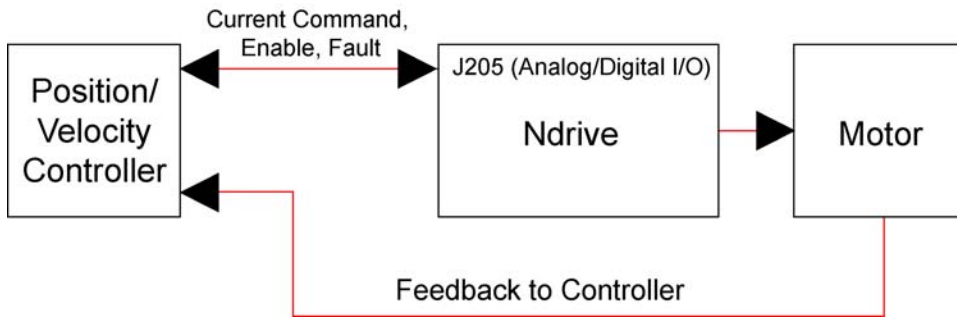

Figure 3-13. Stand-Alone Configuration

This mode allows the drive to be used in a general-purpose current-control mode with older existing control hardware.

3.6.1. Parameter Setup and Hardware Configuration

Setup for the Voltage-to-Current mode should be performed using the Automation 3200 SMC. This software interface should be used to configure the parameters on the drive. The parameters of principal concern are:

- Current Loop Parameters (gains, offsets, etc.)
- Feedback configurations (feedback types, channels, etc.)
- Commutation Information (pole pairs, counts per cycle, etc)
- Current Clamp/RMS Current Trap

These are the parameters that will need to be saved to the flash memory within the Ndrive HL, before the standalone mode is activated. To enter the normal, A3200 operating mode, power down the drive and set DIP switches #6 and #7 to the ON position.

Once the parameters are correctly configured to run the motor with the A3200 (and verified) they can then be saved to the flash memory.



This initial setup should only need to be performed once for a given system type. If the parameter settings for a given axis in the system have already been verified, then on all future systems the A3200 software can be used to load the parameters for that axis into the Ndrive HL/HP so that they can be saved to the flash memory on that drive. Re-configuration should only need to be done for a different system, or if it is expected that some other system parameter may have changed.

3.6.2. Saving Parameters to the Flash Memory on the Drive

Open the Ndebug.exe utility and select the axis (by typing AX n, where n is the 1-based axis number, of the axis you wish to select). Save the parameters to flash memory by typing:

```
FLASHWRITE 1 0 0
```

This will save the current system configuration into the flash memory on the Ndrive HL.

To enter the voltage-to-current mode, power down the Ndrive and set DIP switches #6 and #7 to the OFF position. When the unit is powered on again, it will auto-boot into the voltage-to-current mode.

3.6.3. Operation

In the Voltage-to-Current mode, the Ndrive HL acts as a simple voltage-to-current controller. Analog Input 0 provides the current/torque command. Analog input 0 is accessible through either the -IOPSO option board or the J205 connector.

To emulate a standalone drive, the Ndrive HL also uses Input #8 (least-significant input bit on the J205 connector) as a drive enable input, and Output #8 (least-significant output bit on the J205 connector) as a fault output indicator. These I/O points utilize a default polarity that makes them fail-safe. Both are optically isolated. See Figure 3-2 and Figure 3-3 for I/O connection information. Also, note that the fault output requires a pull-up resistor to an external power supply.

The analog input is configured to accept input voltages from -10V to $+10\text{V}$. In this mode, $+10\text{V}$ is equivalent to peak amplifier current command in the negative (CCW) direction, while -10V is equivalent to peak amplifier current command in the positive (CW) direction. The drives peak current is defined by the drive part number (i.e. Ndrive HL 20 indicates that the peak output current will be 20 amps.)

The analog input is differential, utilizing pins J205-13 (Analog input 0+) and J205-14 (Analog input 0-). See Figure 4-9 for more information.



The diagrams above indicate that current flow through pins 17 and 24 will enable the axis to drive current through the motor (failsafe; by default, no motor current will be present). Also, they indicate that a fault condition will be indicated by no current flow from pin 7 to pin 15 through the fault output (failsafe; by default, no current flow indicates a drive fault. When the drive is powered up and no fault condition exists, the opto-isolator will conduct current).

3.6.4. Faults

A Drive Fault in the standalone mode can be caused by any of the following issues:

- Drive Over-Current (Peak current commanded for 1 second)
- Motor Over-Current (RMS threshold)
- Thermistor Over-Temperature Fault (Motor)
- Amplifier Temperature Fault
- Loss of Bus Power



CHAPTER 4: OPTIONS

4.1. –IOPSO and –IOPSOH Option Boards

See the following sections for details on the connector pin assignment and technical information for the –IOPSO and –IOPSOH options.

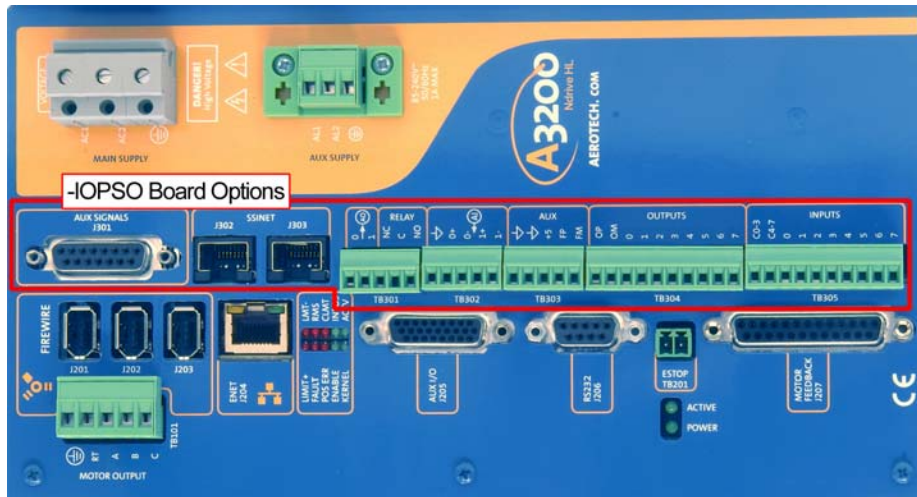

Figure 4-1. –IOPSO Option Board Location

The –IOPSO expansion board has 8 opto-isolated inputs (sinking or sourcing) and 8 outputs (sinking or sourcing), two 18-bit analog outputs, two 16-bit differential analog inputs, SSI Net, absolute encoder interface and brake relay, and includes HCPL2601 opto-isolator.

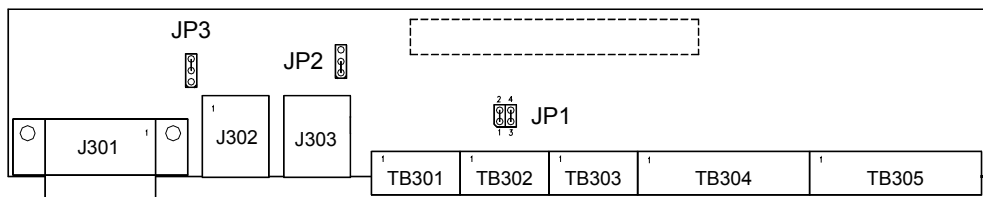

Figure 4-2. –IOPSO Option Board (690D1579 Rev. A)

Table 4-1. –IOPSO Option Board Jumpers

Jumper	Setting	Description
JP1	1-2, 3-4*	Brake Option at J207
	1-3	Auxiliary relay Output Option at TB301 (Remove 1-2, 3-4 and 2-4)
JP2	1-2*	Input 0 at TB305-3 is input 0
	2-3	Input 0 at TB305-3 drives the external Reset Input
JP3	1-2	PSO (Laser Firing) Output is Active High
	2-3*	PSO (Laser Firing) Output is Active Low

*factory default setting

The -IOPSOH expansion board has 8 opto-isolated inputs (sinking or sourcing) and 8 outputs (sinking or sourcing) rated at 1 A per channel, two 18-bit analog outputs, two 16-bit differential analog inputs, SSI Net, absolute encoder interface and brake relay, and includes HCPL2601 opto-isolator.

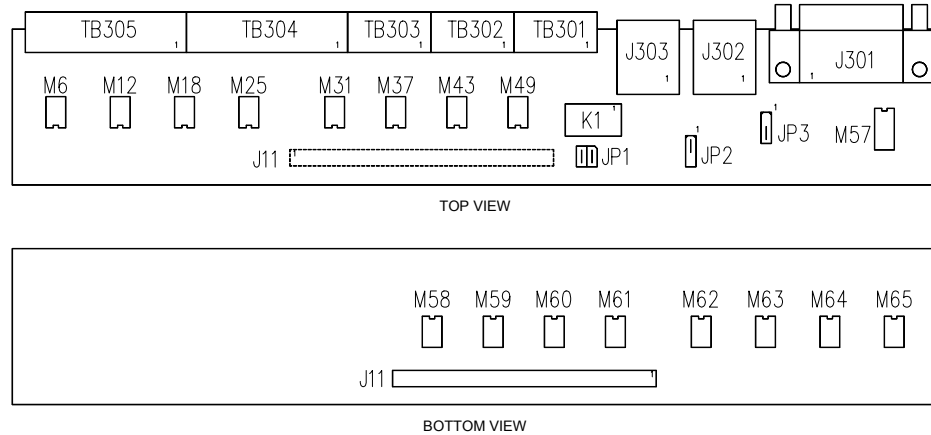

Figure 4-3. -IOPSOH Option Board (690D1623 Rev. 0)

Table 4-2. -IOPSOH Output Device Numbers

Output	Designator	Description	Aerotech P.N.	3 rd Party P.N.
Bit 0	M49	Sourcing Driver	ECS01079	NEC PS710E-1A
	M58	Sinking Driver	ECS01079	NEC PS710E-1A
Bit 1	M43	Sourcing Driver	ECS01079	NEC PS710E-1A
	M59	Sinking Driver	ECS01079	NEC PS710E-1A
Bit 2	M37	Sourcing Driver	ECS01079	NEC PS710E-1A
	M60	Sinking Driver	ECS01079	NEC PS710E-1A
Bit 3	M31	Sourcing Driver	ECS01079	NEC PS710E-1A
	M60	Sinking Driver	ECS01079	NEC PS710E-1A
Bit 4	M25	Sourcing Driver	ECS01079	NEC PS710E-1A
	M62	Sinking Driver	ECS01079	NEC PS710E-1A
Bit 5	M18	Sourcing Driver	ECS01079	NEC PS710E-1A
	M63	Sinking Driver	ECS01079	NEC PS710E-1A
Bit 6	M12	Sourcing Driver	ECS01079	NEC PS710E-1A
	M64	Sinking Driver	ECS01079	NEC PS710E-1A
Bit 7	M6	Sourcing Driver	ECS01079	NEC PS710E-1A
	M65	Sinking Driver	ECS01079	NEC PS710E-1A

4.1.1. Brake Configuration Jumpers

Setting JP1 to 1-2, 3-4 allows connection of the brake relay to pins 13 and 25 of the motor feedback connector (J207). See Figure 4-5 in section 4.1.3 for more information.

4.1.2. Analog Outputs (TB301)

Both analog outputs are driven by an 18-bit AD1868 digital to analog converter and buffered by TL084 op-amps, producing a single-ended output voltage in the range of ±10 volts. This produces a resolution of 76.3 uVolts per bit of the D/A. The output current is limited to less than 50 mA. Note that the analog outputs are referenced to TB302-1 (as shown in Figure 4-4). Analog output 0 is also available at J205 (see Section 3.1.2). The analog outputs will be zero volts during reset.

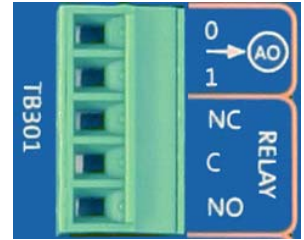

Table 4-3. Analog Output Connector Pin Assignment (TB301)

Pin #	Label	Description	In/Out/Bi.
1	Analog 0 Out	Analog Output 0	Output
2	Analog 1 Out	Analog Output 1	Output

NOTE
The analog output common may be found at J205 pin 23 or TB302 pin 1.

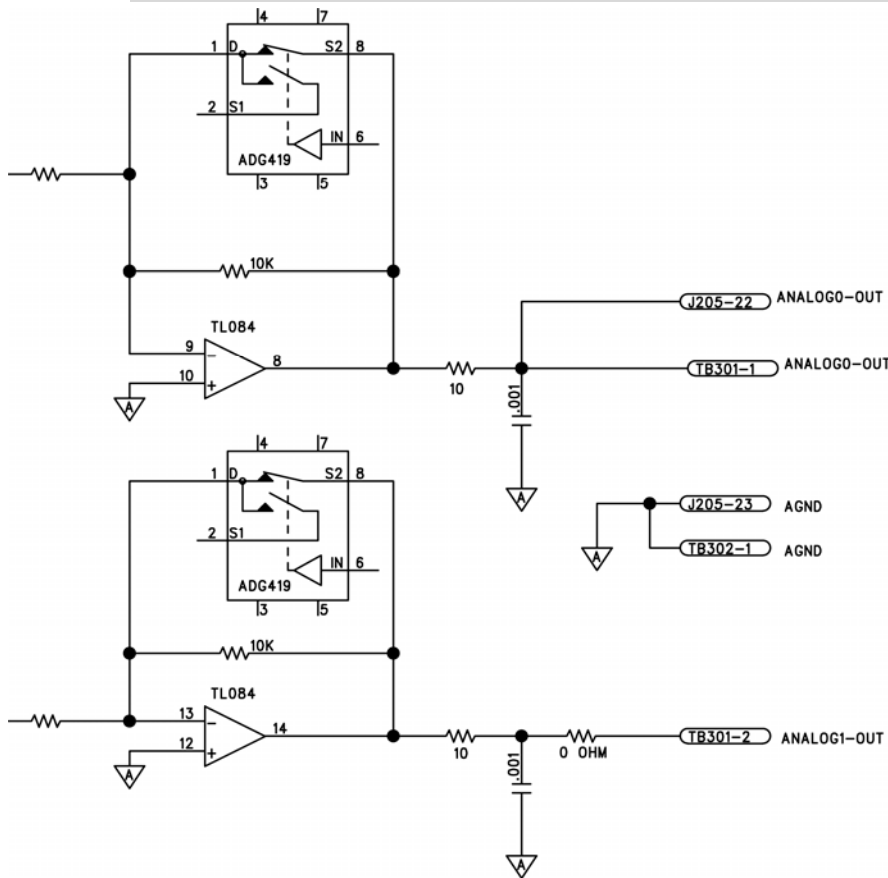
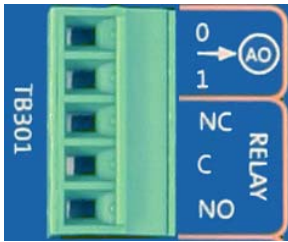

Figure 4-4. Analog Output Connector (TB301)



4.1.3. Brake / Relay (TB301)

The relay output is typically used to automatically drive a fail-safe brake on a vertical axis, however, it may also be used as a general purpose relay. See the BrakeOnDriveDisable axis parameter for information on activating the brake output automatically, or the BRAKE command for manually toggling the output, both in the Nview HMI help. In order to help the user to interface to the brake relay the remainder of this section will be presented as a step-by-step procedure.

Step #1 Brake Relay Specifications

The user must verify that the application will be within the specifications of the Brake Relay contacts. These specifications are provided below in Table 4-4.

Table 4-4. Voltage and Current Specifications (TB301)

Relay K1 Contact Ratings	
Maximum Switched Voltage	150 VDC, 125 VAC
Maximum Switched Current	1A
Maximum Carrying Current	1A
Maximum Switched Power	30W (DC), 60 VA (AC)
Note: The maximum power that may be switched is voltage dependent.	
Initial Contact Resistance	50 milliohms max. @ 10 mA, 6 VDC

NOTE

The user must not exceed the maximum Current or maximum Power specifications.

Step #2 Select Brake Interface Connector

The Normally-Open (N.O.) contacts of the Brake Relay are accessible through TB301 and the Motor Feedback connector (J207). The Normally-Closed contact of the Brake Relay is only accessible through TB301 (see Figure 4-5). The Motor Feedback connector (J207) allows the brake wires to be included in the motor feedback cable and eliminate the need for a separate brake cable. The Brake Relay connections to TB301 are listed in Table 4-5 and the Brake Relay connections to the Motor Feedback connector (J207) are listed in Table 4-6.

Table 4-5. Brake / Relay Connector Pin Assignment (TB301)

Pin #	Label	Description	In/Out/Bi.
3	Relay-N.C.	(Brake) Relay Output Normally Closed Contact	Output
4	Relay-Com.	(Brake) Relay Output Common Contact	Output
5	Relay-N.O.	(Brake) Relay Output Normally Open Contact (See JP1-A, JP1-B)	Output

Table 4-6. Brake / Relay Connector Pin Assignment (J207)

Pin #	Label	Description	In/Out/Bi.
13	Brake -	(Brake-) Relay Output Normally Open Contact (See JP1-A, JP1-B)	Output
25	Brake +	(Brake+) Power connection (See JP1-A, JP1-B)	Output

Figure 4-5 is an example of a 24 VDC Brake connected to TB301. In this example, JP1-A and JP1-B must be configured. If JP1-A and JP1-B are configured to 1-3 then J207 pins 13 and 25 will be unused. If JP1-A is set 1-2 and JP1-B is set 3-4, a connection between pins 13 and 25 of J207 is required. In this case, J207 functions as an interlock to prevent the Brake from releasing if the Motor Feedback connector is not connected.

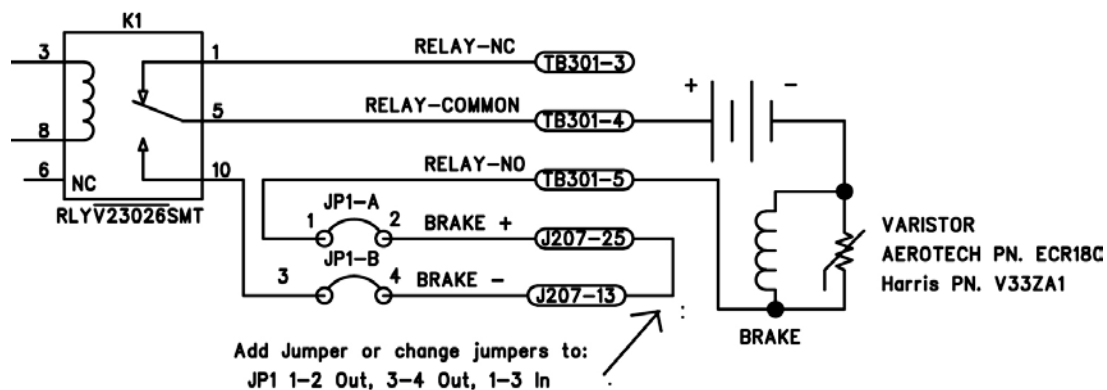

Figure 4-5. Brake Connected to TB301

NOTE

The user may reconfigure the connections for the brake, such that the positive supply lead is switched by the relay instead of the supply common.

Figure 4-6 is an example of a 24 VDC Brake connected to the Motor Feedback connector (J207). In this example the external 24 VDC power source is connected to TB301. Also note that JP1-A is set 1-2 and JP1-B is set 3-4.

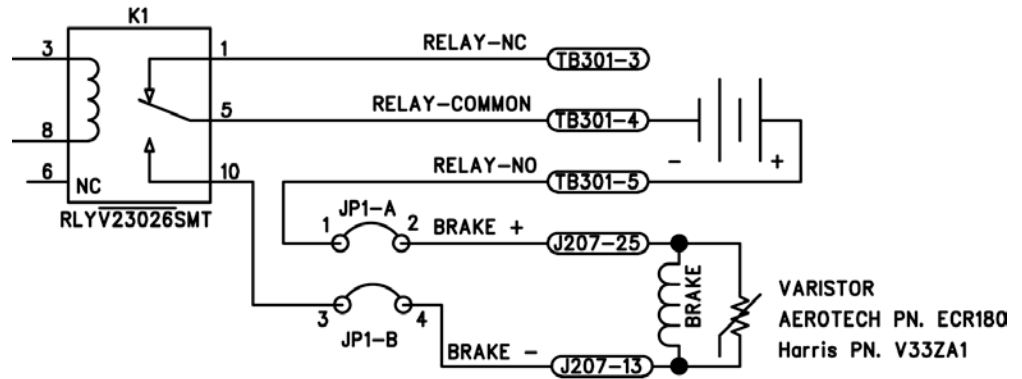

Figure 4-6. Brake Connected to J207

NOTE



The user is responsible for providing fuse protection for the Brake circuit.

NOTE



The user may reconfigure the connections for the brake, such that the positive supply lead is switched by the relay instead of the supply common.

Step #3 Suppression and Snubber Requirements

Due to the inductive effects of the brake, suppression and/or snubber, components are needed to reduce arcing and prevent damage to the Brake Relay contacts. Suppression can also reduce the electrical noise that is emitted when the circuit is switched off. Following are three suppression circuit examples.

Example #1: Figure 4-5 is an example of a typical 24 VDC brake circuit. In this example, the Varistor, is the suppression device, connected across the brake. This method of suppression is used in circuits operating at voltages up to 25 VDC and AC circuits operating at voltages up to 18 VAC. If the voltage is greater than 25 VDC or 18 VAC, one of the other suppression methods should be used.

Example #2: Figure 4-7 is an example of a suppression circuit that can be used for systems using a DC supply. In this example, the diode is the suppression component, which is connected across the brake. It is important that the diode be installed, so that it is normally reversed biased. This diode must have a reverse voltage rating greater than the users DC power supply and a maximum current rating of at least 1 Ampere. Due to the time needed for this suppression device to dissipate the energy released by the load inductance there may be a slight delay (less than 1 second) before the brake responds to its power being switched off. If this delay is unacceptable, Example #3 should be used.

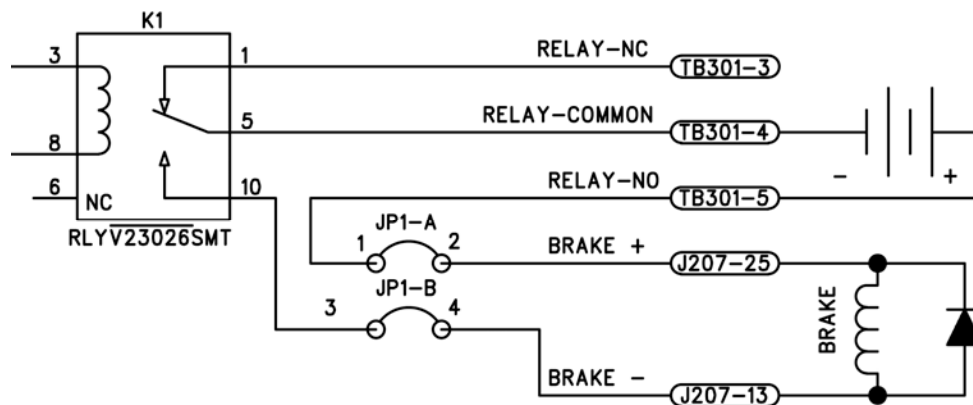

Figure 4-7. Diode Suppression for DC Brake Systems



The user may reconfigure the connections for the brake, such that the positive supply lead is switched by the relay instead of the supply common.

Example #3: Figure 4-8 is a suppression circuit that can be used for both AC and DC circuits. In this method, a resistor, capacitor and a varistor are used across the load (see Figure 4-8). In some cases, better results are obtained by installing the suppression devices across the relay contacts. The ratings and values for these components are described below.

Resistor (R): calculated by the following formula, Power rating = $\frac{1}{2}$ Watt.

$$\text{Resistor (ohms)} = \text{Voltage} / \text{Load current}$$

If the Resistor is less than 24 ohms use 24 ohm resistor.

If the Resistor is greater than 240 ohms use 240 ohm resistor.

If the resistance of the Resistor is too low the relay contacts may fuse together.

If the resistance of the Resistor is too high, the contacts may be damaged due to excessive arcing.

Capacitor (C): .1 uF, rated for AC circuits and a voltage rating of not less than 250 Volts. If the voltage rating of the capacitor is too low, the Varistor may not be able to protect it and it may fail.

Varistor (V): Rated for the maximum voltage of the users power supply, Typically, a varistor rated for a standard 120 VAC line should work well. Verify that the capacitor voltage rating is greater than the clamp voltage of the varistor. If the voltage rating of the varistor is too low, it may conduct during normal operation and overheat. If the voltage rating of the varistor is too high, it may not protect the capacitor (C) against over-voltage conditions.

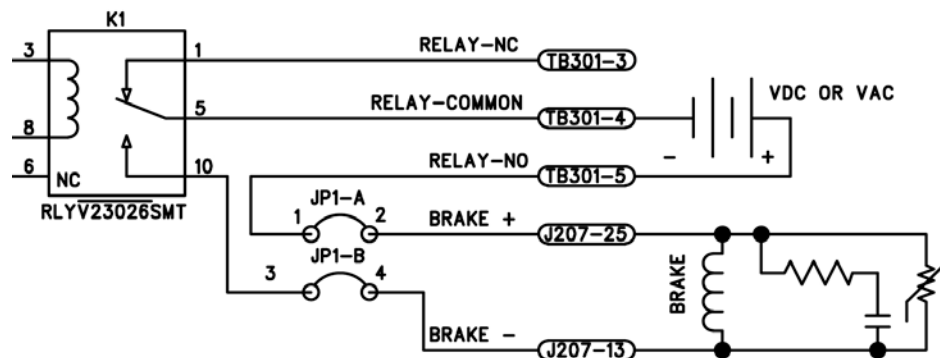

Figure 4-8. RC Suppression for DC Brake Systems

NOTE

The user may reconfigure the connections for the brake, such that the positive supply lead is switched by the relay instead of the supply common.

4.1.4. Analog Inputs (TB302)

Both analog inputs are differential, buffered by a precision unity gain differential INA105 amplifier and converted to digital by a 16-bit ADS8320 analog to digital converter allowing an input voltage in the range of ± 10 volts. This produces a resolution of 305 uVolts per bit of the A/D.

Analog input 0 is also available at J205, see Section 3.1.3. The analog inputs have a 25k Ohm input impedance and should be driven by a low impedance source such as an op-amp output.

To interface to a single-ended (non-differential) voltage, refer to Figure 4-9; connect the signal common of the source to the negative (-) input and connect your signal to the positive (+) input. A floating signal source should be referenced to the signal common (pin 1, AGND) as shown in Figure 4-9.

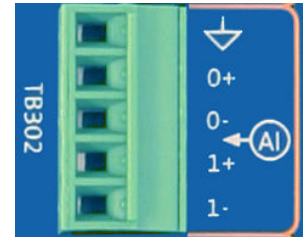

Table 4-7: Optional Analog Input Connector Pin Assignment (TB302)

Pin #	Label	Description	In/Out/Bi.
1	Analog Ground	Analog Common	N/A
2	Analog0 In +	Non-Inverting Analog Input 0	Input
3	Analog0 In -	Inverting Analog Input 0	Input
4	Analog1 In +	Non-Inverting Analog Input 1	Input
5	Analog1 In -	Inverting Analog Input 1	Input

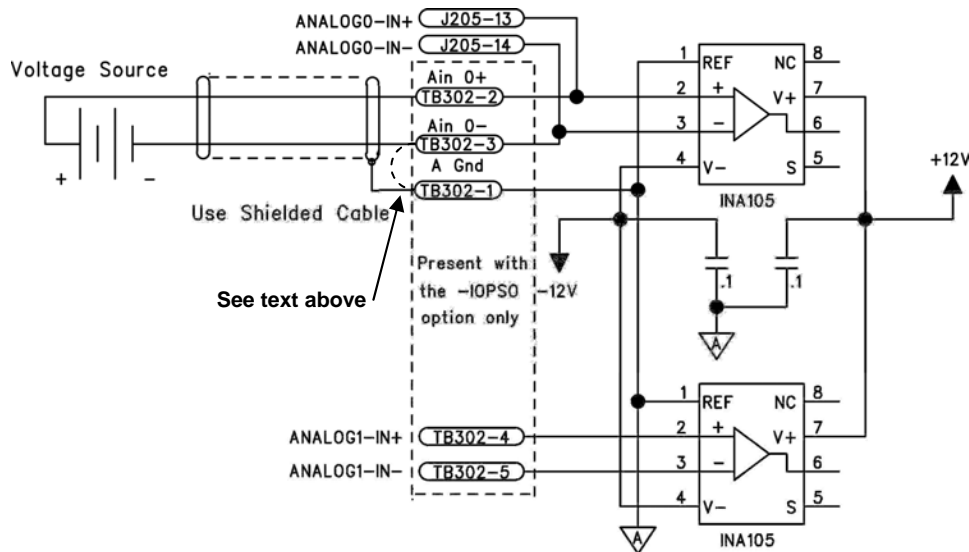
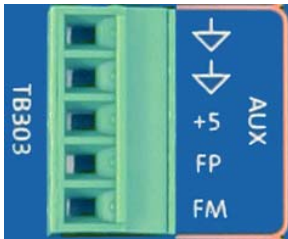

Figure 4-9: Optional Analog Input Connector (TB302)



4.1.5. User Power Connector (TB303)

This connector provides access to the Ndrive HL's internal power supply, which may be used to power external devices (500 mAmps maximum). It also provides a connection to power the opto-isolated PSO output (see Section 4.1.8., Figure 4-15).

Table 4-8. User Power Connector Pin Assignment (TB303)

Pin #	Label	Description	In/Out/Bi
1	+5 User Return	User +5 Volt Signal Common	N/A
2	+5 User Return	User +5 Volt Signal Common	N/A
3	+5 Ext.	User +5 Volt Power *	Output
4	FP	Power for PSO opto-isolated output	Input
5	FM	Common for PSO opto-isolated output	N/A

* Total user +5V power from all outputs is limited to 500mA, by an internal re-settable fuse.

4.1.6. Opto-Isolated Outputs (TB304)

The outputs are software configurable via the DriveIOConfig axis parameter as sourcing or sinking, and are driven by a PS2802-4 opto-isolator that is rated for 40 volts DC maximum and up to 80 mA/channel, not to exceed 90 mW per channel. Figure 4-10 and Figure 4-11 illustrate how to connect to the output in current sinking and current sourcing modes, respectively.



The connection must always be made to both the Output Common Plus and Output Common Minus connections to prevent glitches on the outputs, as shown in the wiring diagrams in Figure 4-10 and Figure 4-11.

Table 4-9. Opto-Isolated Output Connector Pin Assignment (TB304)

Pin #	Label	Description	In/Out/Bi
1	OP	Output Common Plus	Input
2	OM	Output Common Minus	Input
3	Output 0	Output 0 (optically isolated)	Output
4	Output 1	Output 1 (optically isolated)	Output
5	Output 2	Output 2 (optically isolated)	Output
6	Output 3	Output 3 (optically isolated)	Output
7	Output 4	Output 4 (optically isolated)	Output
8	Output 5	Output 5 (optically isolated)	Output
9	Output 6	Output 6 (optically isolated)	Output
10	Output 7	Output 7 (optically isolated)	Output

Table 4-10. Output Specifications (TB304)

Specification	-IOPSO Value	-IOPSOH Value
Maximum Power Dissipation	90 mWatts / Channel	600 mWatts / Channel
Maximum Voltage	40 Volt Maximum	24 Volt Maximum
Maximum Sink/Source Current	80 mAmps / Channel	1 Amperes / Channel
Output Saturation Voltage	~ 0.7 – 0.9 Volts	~ 0.32 Volts
Rise / Fall Time	250 usec (typical)	1 msec (typical)
Maximum Output Frequency	1 kHz	100 Hz

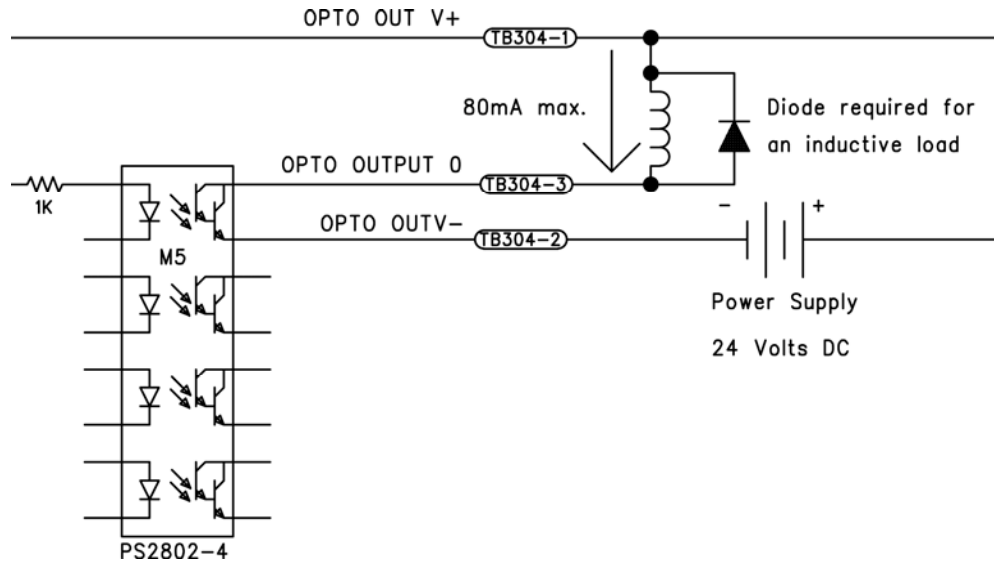

Figure 4-10. Connecting Outputs in Current Sinking Mode

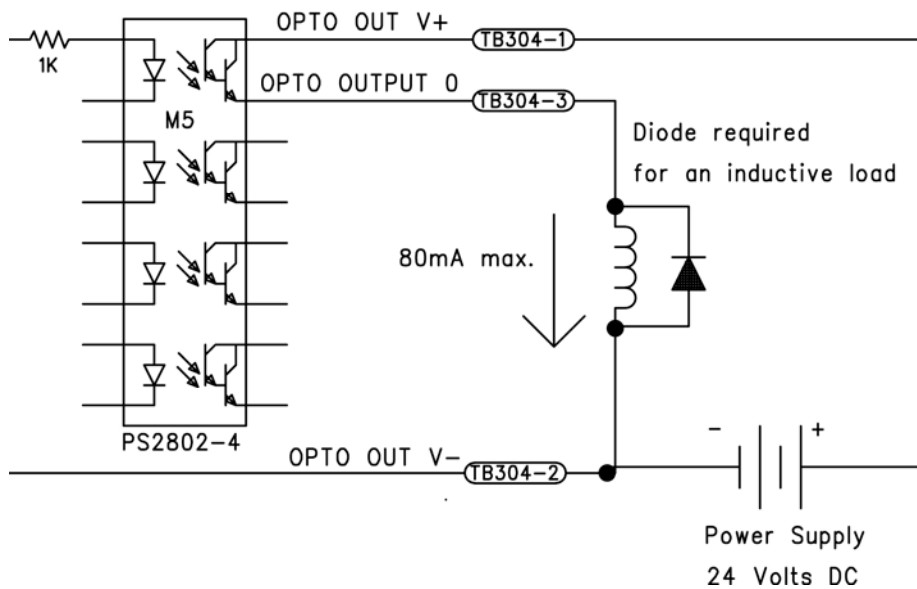

Figure 4-11. Connecting Outputs in Current Sourcing Mode

Suppression diodes must be installed on outputs that are used to drive relays or other inductive devices to protect the output devices from being damaged by the inductive spikes that occur when the device is turned off. Suppressor diodes can be installed on all outputs to provide greater protection. The 1N914 diode is recommended for this application. It is important that the diode be installed correctly (normally reversed biased). See Figure 4-10 for an example of a current sinking output with diode suppression and Figure 4-11 for an example of a current sourcing output with diode suppression.

4.1.7. Opto-Isolated Inputs (TB305)

The inputs are configured for 5-24 volts DC logic, using a higher input voltage, requires adding external series resistors to limit the current. The opto-isolator is a PS2806-4 device. The inputs may be connected to current sourcing or current sinking devices, as shown in Figure 4-12 and Figure 4-13. Each 4-bit bank of inputs (0-3 or 4-7) must be connected to either all current sourcing or all current sinking devices. Also, note in the table below, that inputs 0-3 and inputs 4-7 have two different common inputs, pin 1 and pin 2, respectively. See Section 3.3.1 for opto-isolated EOT limit inputs.

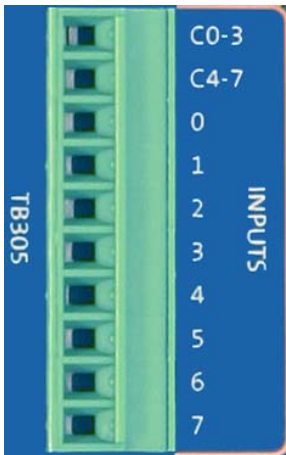

Table 4-11. Opto-Isolated Input Connector Pin Assignment (TB305)

Pin #	Label	Description	In/Out/Bi
1	C0-3	Input Common for inputs 0 - 3	Input
2	C4-7	Input Common for inputs 4 - 7	Input
3	Input 0	Input 0 (Optically-Isolated) – See pin 1	Input
4	Input 1	Input 1 (Optically-Isolated) – See pin 1	Input
5	Input 2	Input 2 (Optically-Isolated) – See pin 1	Input
6	Input 3	Input 3 (Optically-Isolated) – See pin 1	Input
7	Input 4	Input 4 (Optically-Isolated) – See pin 2	Input
8	Input 5	Input 5 (Optically-Isolated) – See pin 2	Input
9	Input 6	Input 6 (Optically-Isolated) – See pin 2	Input
10	Input 7	Input 7 (Optically-Isolated) – See pin 2	Input

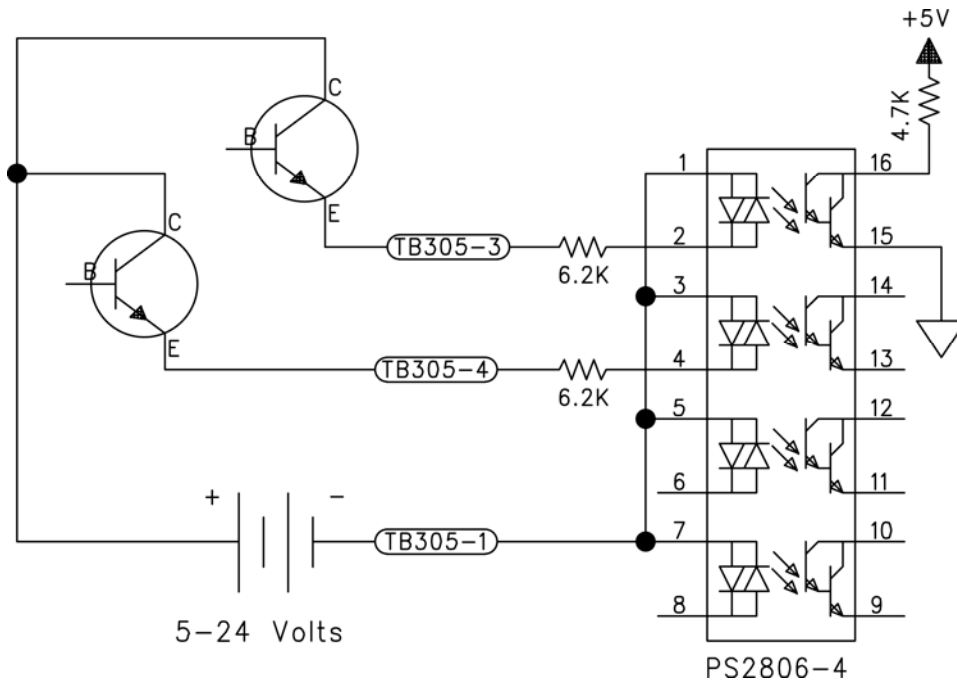

Figure 4-12. Inputs Connected in Current Sourcing Mode

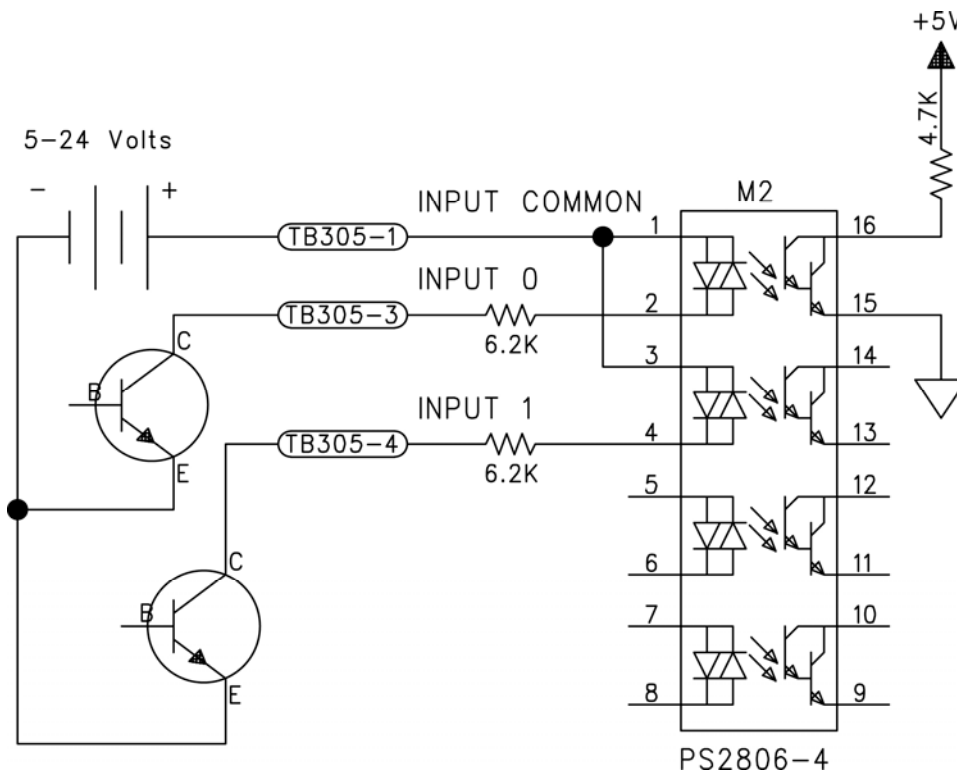
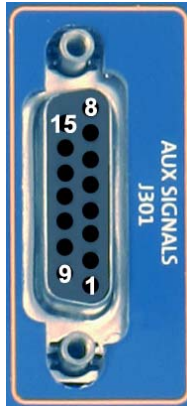

Figure 4-13. Inputs Connected in Current Sinking Mode



4.1.8. PSO / Absolute Encoder Interface (J301)

This connector utilizes the RS-485 port and the (analog sine wave) encoder channel as an absolute encoder interface. The absolute encoder channel accepts a differential analog encoder up to 200 kHz. Typically, this is a 1 Volt P-P signal varying about a 2.5 Volt reference. See Figure 2-5, Figure 2-6, Figure 2-7, and Figure 2-11 in Section 2.4. for connection information. The two RS-422 channels provide buffered and/or multiplied MXH encoder signals to the user, for laser firing or other purposes. Additionally, the – IOPSO option provides a RS-422 output and an open-collector laser-firing signal to the user. Only one of these signals may be used, as illustrated in Figure 4-15. Jumper JP3 defines the active state of the open-collector output, which has three options, as defined in Table 4-12. See Section 4.2. for more information on the laser firing (PSO) option. Note that the two RS-422 channels are two of the same channels available on the J302 and J303 connectors. For information on the RS-422 ports, see Figure 4-17 in Section 4.1.9.

See Figure 4-15 for the firing output.

Table 4-12. PSO/Absolute Encoder Interface Connector Pin Assignment (J301)

Pin #	Label	Description	In/Out/Bi
1	Chassis Frame Ground	Chassis Frame Ground	N/A
2	Sin-N	SSI Net #1 Sin-N	Bi-directional
3	Sin	SSI Net #1 Sin	Bi-directional
4	Cosine-N	SSI Net #1 Cosine-N / Marker-N	Bi-directional
5	Cosine	SSI Net #1 Cosine / Marker	Bi-directional
6	Common (+5 Volt External)	Common	N/A
7	Absolute Sine + Input	Absolute Encoder Interface	Input
8	Absolute Sine - Input	Absolute Encoder Interface	Input
9	Absolute Cosine + Input	Absolute Encoder Interface	Input
10	Absolute Cosine – Input	Absolute Encoder Interface	Input
11	PSO-IOC/RS-422-M Output	PSO / RS-422 - Output *	Output
12	RS-422-P Output	RS-422 +	Output
13	+5 Volt External – See Pin 6	External +5 Volt supply	Output
14	RS-485-M	RS-485 – for Abs. Encoder	Bi-directional
15	RS-485-P	RS-485 + for Abs. Encoder	Bi-directional

* Users should use the opto-isolated output where possible to maintain the isolation between the Ndrive HL and the laser. This prevents noise and current spikes (from laser firing pulses) from being conducted through the Ndrive HL! This requires the user to power the opto-isolator at TB303 (see Section 4.1.5. for more information).

Table 4-13. PSO / Absolute Encoder Mating Connector (J301)

15-Pin D-Style	Aerotech	Third Party Source
Connector	ECK00100	Keltron P/N DN-15PYSH-G
Back shell	ECK01022	Amphenol P/N 17-1725-2

Table 4-14. Laser Output Opto-Isolator Specifications

M12 Device (Option#) (Figure 4-15)	Nominal Frequency	Propagation Delay (Typ.)	Power Supply Voltage	Output Current Sink
*HCPL-2601 (-PSOOPTO1 option, std)	5 MHz	.05 us.	5 VDC	10 mA
6N136 (-PSOOPTO2 option)	750 KHz	.45 us.	5-15 VDC	2 mA
4N33 (-PSOOPTO3 option)	10 KHz	3 us.	5-25 VDC	50 mA
TIL117-M (-PSOOPTO4 option)	40 KHz	2 us.	5-25 VDC	50 mA

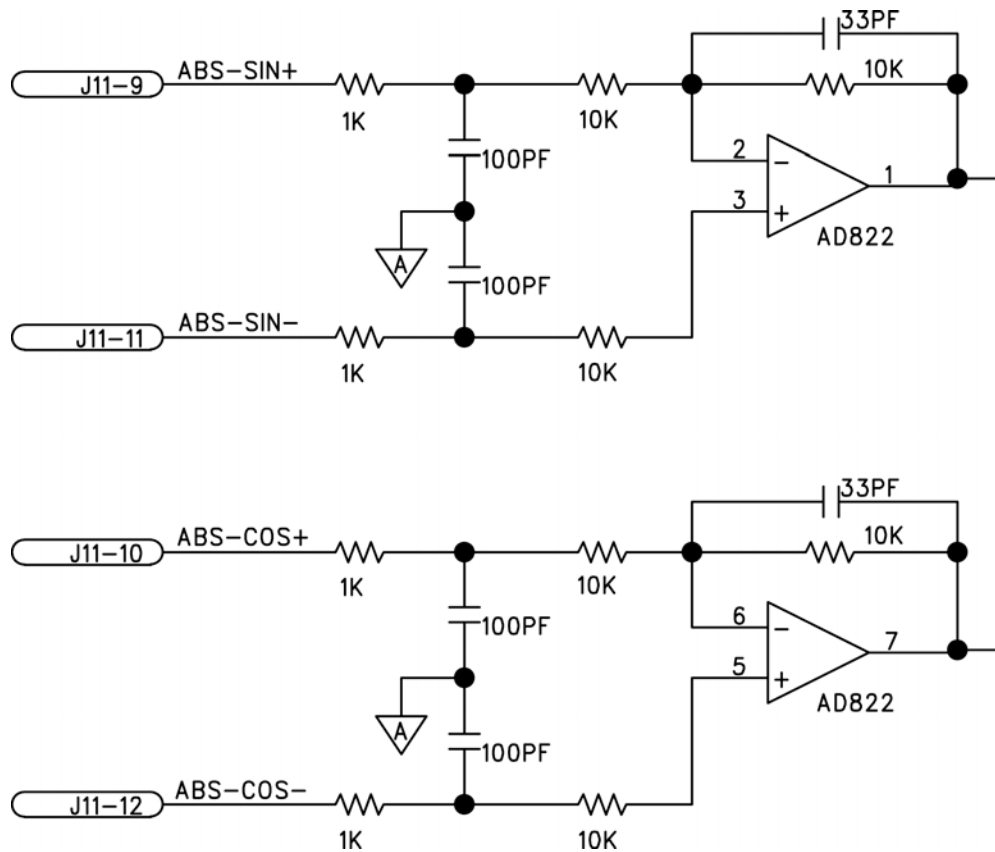

Figure 4-14. Absolute Encoder Interface (J301)

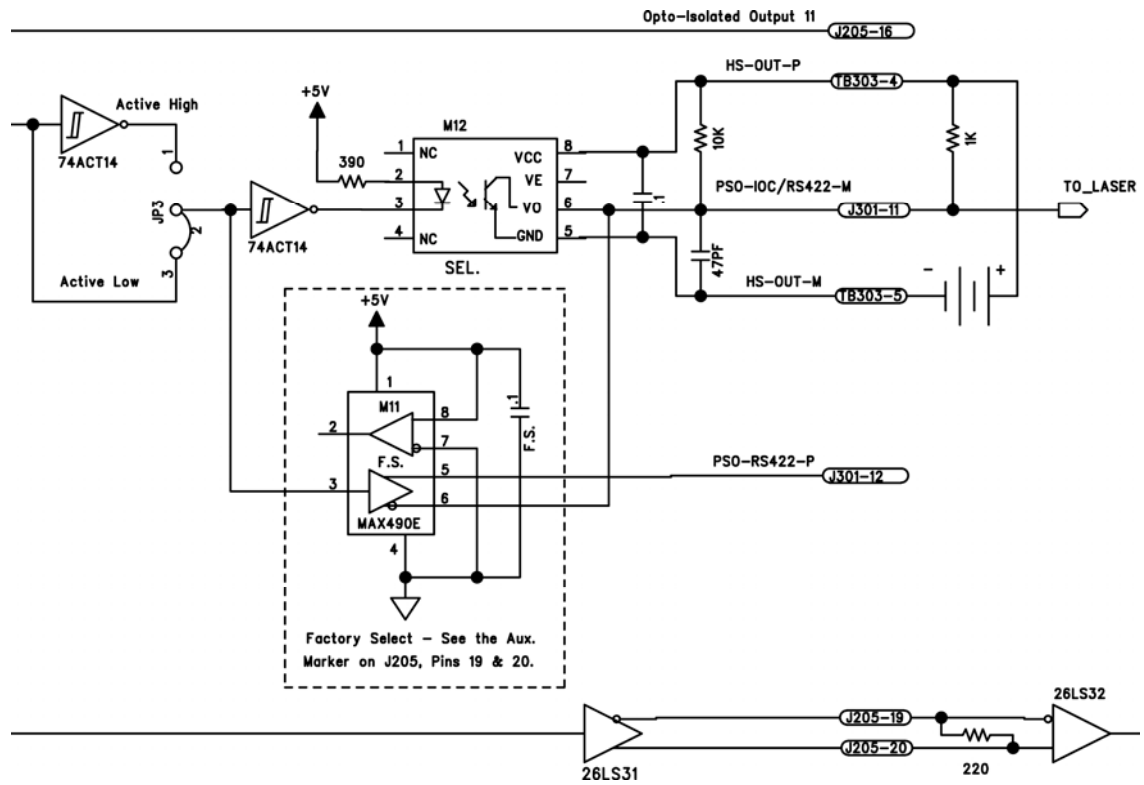

Figure 4-15. PSO Interface (J301 and TB303)

Output 11 and the Auxiliary Marker on J205 (pins 19 and 20) may also be defined as the PSO Laser Firing output via the PSOCONTROL command. See Section 3.2 for connection and other information.

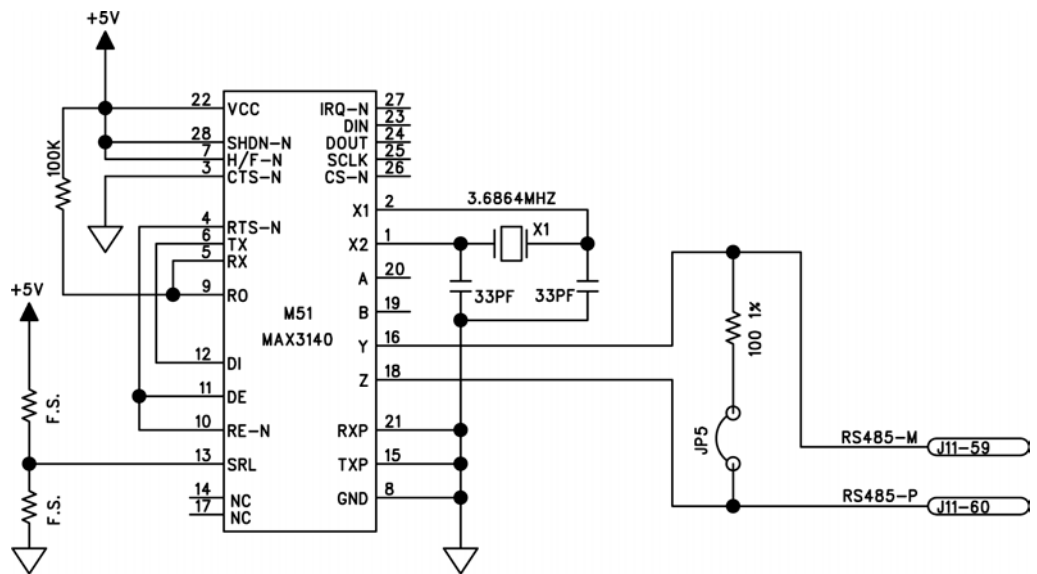

Figure 4-16. (RS-485) Absolute Encoder Interface (J301)

4.1.9. SSI Net (2 channel) (J302, J303)

Each of the two SSI Net interfaces is a two-channel bidirectional RS-422 interface, most typically for quadrature encoders. This allows one channel for the sine signal and one channel for the cosine signal. Alternatively, one of the SSI Net interfaces may be used to provide an encoder marker signal to another SSI Net interface if used. Each of these two SSI Net interfaces are both available on the J302 and J303 connectors, as illustrated in the following table. Note that the J205 encoder channel may also be used as an input/output for multi-axis PSO firing.

The SSI Net is designed for daisy-chaining encoder signals from one Ndrive HL to another for two/three-axis PSO (laser firing). This allows one Ndrive HL containing the –DUALPSO or –TRIPLEPSO options to track the vectorial position change of two/three axes in real-time. These encoder signals may also be used for user-defined purposes. Refer to Figure 4-17 and Figure 4-18. These four channels are bi-directional and configured via the PsoSsiConfig and PsoSsi2Config axis parameters; see the Nview help for more information. Note that SSI Net #1 is also available on the J301 connector (see Section 4.1.8.). The signals from these ports will be the same as the differential line driver encoder signal input to the Ndrive HL, unless the –MXH option is present. The signal output, when the –MXH option is present, will be of a pulse width determined by the –MXH clock frequency, as indicated in Table 3-17.



SSI Net #1 and #2 interfaces are both physically hardwired to the J302 AND J303 connectors. If SSI Net #1 is configured as an input, a signal driven into the SSI Net #1 connections on J302, will also be present on the SSI Net #1 connections of J303, effectively making SSI Net #1 on J303 an (un-buffered) output of this same signal. Likewise, this would also be true for the SSI Net #2 interface.

Table 4-15. J302, J303 2-Channel SSI Net Connector Pin Assignment

Pin #	Label	Description	In/Out/Bidirectional
1	Sin-N	SSI Net #1 Sin-N	Bidirectional
2	Sin	SSI Net #1 Sin	Bidirectional
3	Cosine-N	SSI Net #2 Cosine-N / Marker-N	Bidirectional
4	Sin-N	SSI Net #2 Sin-N	Bidirectional
5	Sin	SSI Net #2 Sin	Bidirectional
6	Cosine	SSI Net #2 Cosine / Marker	Bidirectional
7	Cosine-N	SSI Net #1 Cosine-N / Marker-N	Bidirectional
8	Cosine	SSI Net #1 Cosine / Marker	Bidirectional

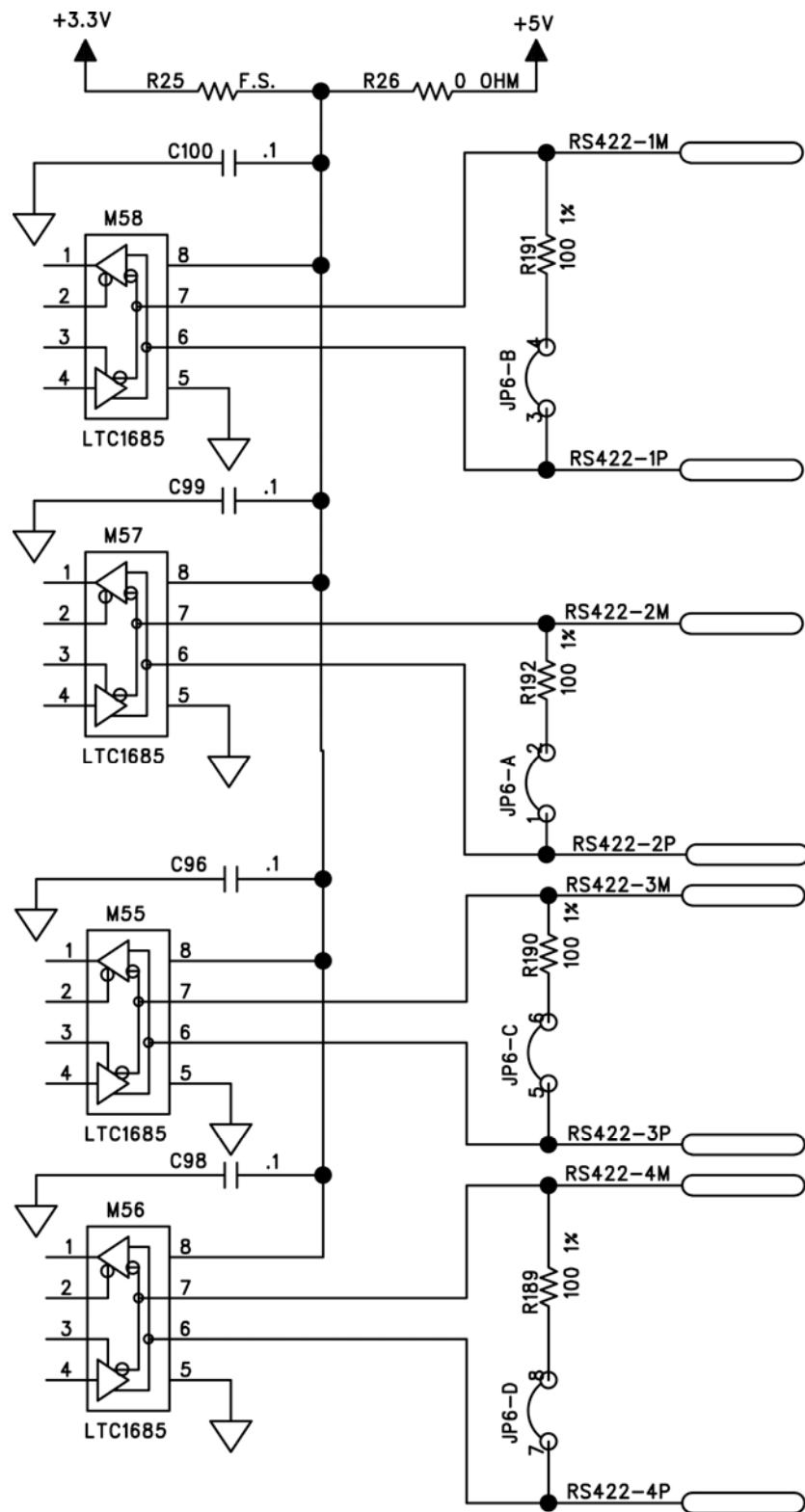

Figure 4-17. J301/J302/J303

4.2. –DUALPSO and –TRIPLEPSO Laser Firing Options

The Ndrive HL allows two and three-axis laser firing with its –DUALPSO and –TRIPLEPSO options. To accomplish this, the encoder signals from a second/third Ndrive HL must be connected (or daisy-chained) from that Ndrive HL to the Ndrive HL with the –DUALPSO or –TRIPLEPSO options. This requires an encoder signal from another axis via the J205 connector (Section 3.2) or via one of the J302, J303 SSI Net connectors. If the J205 connector is used, it must be configured as an output via the EncoderDivider axis parameter. If the SSI Net is used it requires a cable (see Table 4-16 and Figure 4-18) from J302 to J302 of each Ndrive HL (J302 to J302 or J303 to J303 of the other Ndrive HL, both connectors each have the same two SSI Net ports present on each connector). The ports on each drive must then be configured via their PsoSsi1Config/PsoSsi2Config (or PsoMrk1Config/PsoMrk2Config) axis parameters, out and in, respectively, so the encoder signals are supplied to the Ndrive HL with the –DUALPSO or –TRIPLEPSO options. Additionally, the CfgEncMxhSetup axis parameter must be configured for a 20 MHz. clock or less, so as not to exceed the 31 nsec. minimum edge separation specification. Also, the PSO pre-scalars may be required to limit each encoder being tracked to a 5 MHz. data rate (which does not affect the servo feedback loop data rate). The figure below shows two and three-axis firing, which are very similar. See the Nview HMI help for more information on parameter configurations.

Note that the J205 encoder channel may be configured as an output via the EncoderDivider axis parameter, allowing other multi-axis PSO firing configurations.

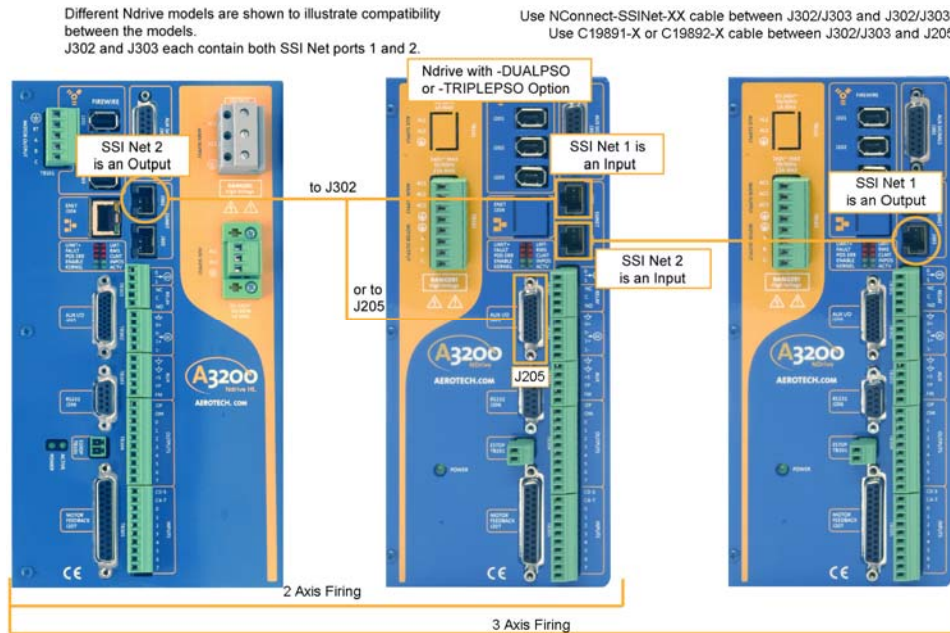

Figure 4-18. Two / Three Axis Laser Firing Interconnection

Table 4-16. SSI Net Cable Part Numbers

Part #	Description
NConnect-SSINet-4500	4.5 M (15 FT) SSI Net Cable
NConnect-SSINet-3000	3.0 M (10 FT) SSI Net Cable
NConnect-SSINet-1500	1.5 M (5 FT) SSI Net Cable
NConnect-SSINet-900	0.9 M (3 FT) SSI Net Cable

4.2.1. PSO Tracking Rate Configuration

NOTE

The following only applies to Ndrive HLs with the –DUALPSO or –TRIPLEPSO options and the MXH option, with high encoder data rates.

The maximum clock frequency of the MXH multiplier should be limited to 20 MHz. when using the –DUALPSO or –TRIPLEPSO options. This is due to a maximum encoder data rate of approximately 32 MHz. on the Ndrive HLs encoder input ports. The 20 MHz. clock rate is achieved by setting the “Clock Select 1” field of the CfgFbkEncMxhSetup axis parameter (value of 0x1 as shown below). This must be done when using –DUALPSO or –TRIPLEPSO options in order to ensure that encoder count information is not lost.

The 20 MHz. data rate limitation effectively limits the maximum speed of the axis (see **B** below). In addition, the –DUALPSO or –TRIPLEPSO options have a maximum tracking rate of 5 MHz. due to hardware limitations. The PSO data rate can be reduced to 5 MHz. while allowing the servo loop to operate at 20 MHz. by using the following **PSOTRACK <axis> SCALE 4 4 4** command. This command divides the encoder signals before the PSO counters by a factor of 4 and therefore limits the frequency seen by the PSO tracking counters to 5 MHz. However, the servo loop is still able to run at the full 20 MHz. rate.

The effective PSO programming resolution is now 1/4 that of the servo loop (full) resolution. PSODISTANCE commands should be entered 4 times lower than the full resolution in this case.

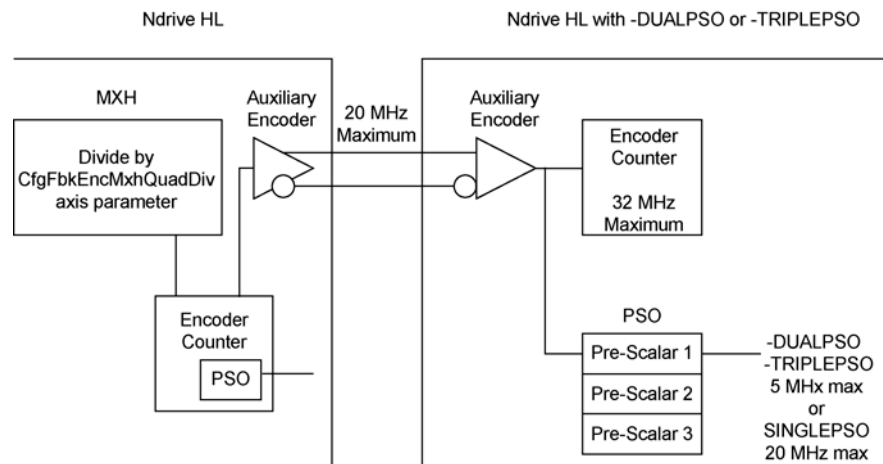

Figure 4-19. PSO Tracking Rate Block Diagram

EXAMPLE:

It is desired to generate a pulse output every 1,000 encoder counts in –DUALPSO or –TRIPLEPSO mode. The individual axis speeds approach 20 MHz. during the motion and therefore exceed the 5 MHz. –DUALPSO or –TRIPLEPSO tracking limitation. The PSOTRACK <axis> SCALE 4 4 command must be used and the PSODISTANCE values reduced by a factor of 4 as follows...

```
PSODISTANCE X FIXED 250 STEPS ; distance specified with 1/4
                                ; actual resolution
```

In order to run the servo loop at full encoder resolution and data rates above 20 MHz., Ndrive HL software versions 2.02 and above contain the CfgFbkEncMxhQuadDiv axis parameter which acts as an MXH output divider. This parameter allows you to specify a lower resolution for the MXH quadrature output signal only (used by –DUALPSO or –TRIPLEPSO options on other drives). The effective resolution is the full resolution, as derived using CfgFbkEncMultFactorMXH axis parameter, divided by the CfgFbkEncMxhQuadDiv axis parameter.

NOTE

The servo loop always runs at the full resolution as determined by the CfgFbkEncMultFactorMXH axis parameter. The CfgFbkEncMxhQuadDiv axis parameter does not affect servo loop resolution.

EXAMPLE:

An application uses a 4um linear encoder with an MXH option on an Ndrive HL. It is desired to move the motor at a maximum speed of 200mm/second and track using the –DUALPSO or –TRIPLEPSO option.

```
CfgFbkEncMultFactorMXH = 500 ; value for 2nm servo loop
                                ; resolution
```

Encoder resolution = 250 lines /mm * 500 * 4 = 500,000 counts / mm (2nm)

Encoder data rate at 200mm/sec = 500,000 * 200 = 100Mhz

This exceeds the –DUALPSO or –TRIPLEPSO maximum encoder tracking rate of 5 MHz. and must be reduced by 100/5 = 20. Set the CfgFbkEncMxhQuadDiv axis parameter to 20 to achieve this. The user must now program the PSODISTANCE command in units of 40 nm instead of 2 nm.

4.3. –ENET (Ethernet) Option J204

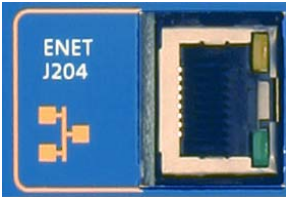

The optional Ethernet port provides connectivity to a 10/100 Base-T ModBus TCP network, or the PC's Ethernet port may be used. This is typically used for adding analog and digital I/O to the controller. See the Ethernet I/O help on the Windows Start bar on the Automation 3200 menu. Additionally, the –IOPSO option provides analog and digital inputs and outputs, see Section 4.1 for more information.

Table 4-17. Ethernet Connector Pin Assignment (J204)

Pin #	Label	Description	In/Out/Bi.
1	TX +	Transmit Data +	Output
2	TX -	Transmit Data -	Output
3	RX +	Receive Data +	Input
4	Unused	RC Terminated	N/A
5	Unused	RC Terminated	N/A
6	RX -	Receive Data -	Input
7	Unused	RC Terminated	N/A
8	Unused	RC Terminated	N/A

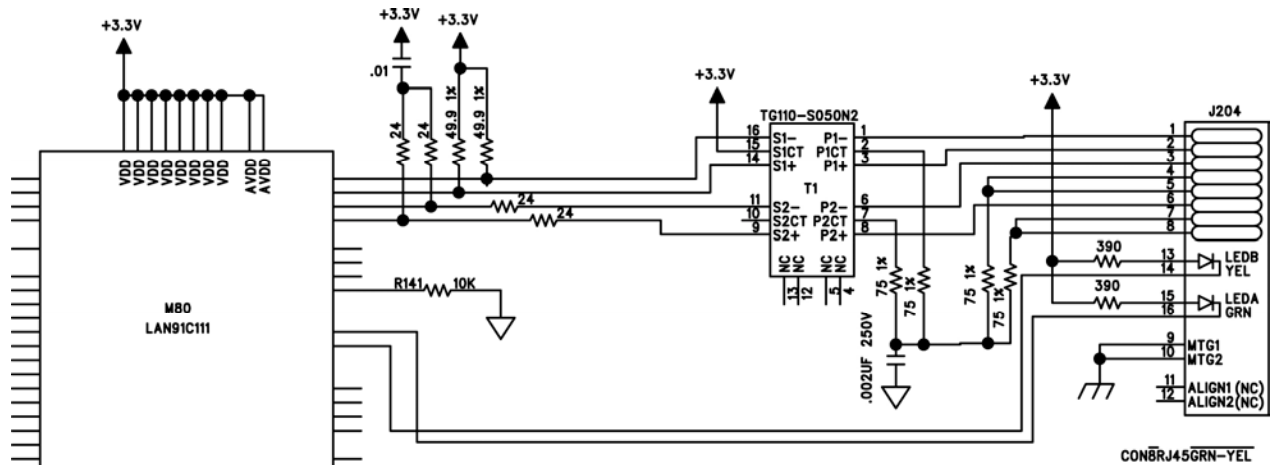

Figure 4-20. Ethernet Interface (J204)

Table 4-18. NConnect I/O Cable part Numbers

Part Number	Description
NConnect-IO-900	Ethernet crossover cable 900mm (3 ft.)
NConnect-IO-1500	Ethernet crossover cable 1500mm (5 ft.)
NConnect-IO-3000	Ethernet crossover cable 3000mm (10 ft.)
NConnect-IO-4500	Ethernet crossover cable 4500mm (15 ft.)

4.4. –RDP Resolver Input

The optional resolver input provides two industry standard resolver or Inductosyn channels, which may each be used as a feedback device. Each may be separately configured for resolver or inductosyn input, as shown in Table 4-21. The standard reference output frequency is 10 kHz, optionally it may be configured as 5 or 7.5 kHz at the factory.

The Sine and Cosine feedback signals should be adjusted for 2 volts RMS (2.8 volts Peak) via the CfgFbkRDGain axis parameter. The resolver can be physically aligned to the motor, by using the MSET CNC programming command. This physical relationship may also be defined via the CfgMotOffsetAng axis parameter. All of which is described in Section 4.4.1. See the Nview help for information on configuring the axis parameters for an axis with resolver feedback.

The J403 external power connector is not available at this time.



Table 4-19. Resolver Connector Pin Assignment (J1, J2)

Pin #	Label	Description	In/Out/Bidir.
Shell	Shield	Connector shell for cable shield termination	Input
1	Enc Cos +	Optional Encoder Cosine + output	Output
2	Enc Mrk +	Optional Encoder Marker + output	Output
3	Common	Resolver Common input	Input
4	Sin +	Resolver Sine + input	Input
5	Sin -	Resolver Sine - input	Input
6	Enc Cos -	Optional Encoder Cosine - output	Output
7	Enc Sin +	Optional Encoder Sine + output	Output
8		Reserved	N.A.
9	Common	Resolver Reference Common input	Input
10	Reference	Resolver Reference output	Output
11	Enc Sin -	Optional Encoder Sine - output	Output
12	Enc Mrk -	Optional Encoder Marker - output	Output
13	Common	Resolver Common input	Input
14	Cos +	Resolver Cosine + input	Input
15	Cos -	Resolver Cosine - input	Input

The following mating connector is always provided with the resolver option, which may be ordered separately as part number, MCK-15HDD.

Table 4-20. Resolver Mating Connector (15-Pin Male D-Style)

	Aerotech	Third Party Source
Connector	ECK01287	Amphenol 17HD-015P-AA000
Back shell	ECK01021	Amphenol 17-1724-2

Table 4-21. Resolver Jumper Configuration

Axis/JP #	Resolver	Inductosyn
JP1	1-2 (Channel 1) - Default	2-3 (Channel 1)
JP2	1-2 (Channel 2) - Default	2-3 (Channel 2)

Table 4-22. Resolver Test Points

Test Point Number	Description
TP4	Signal Common
TP10	Sine input Channel 1
TP11	Cosine input Channel 1
TP12	Reference signal Channel 1
TP20	Sine input Channel 2
TP21	Cosine input Channel 2
TP22	Reference signal Channel 2

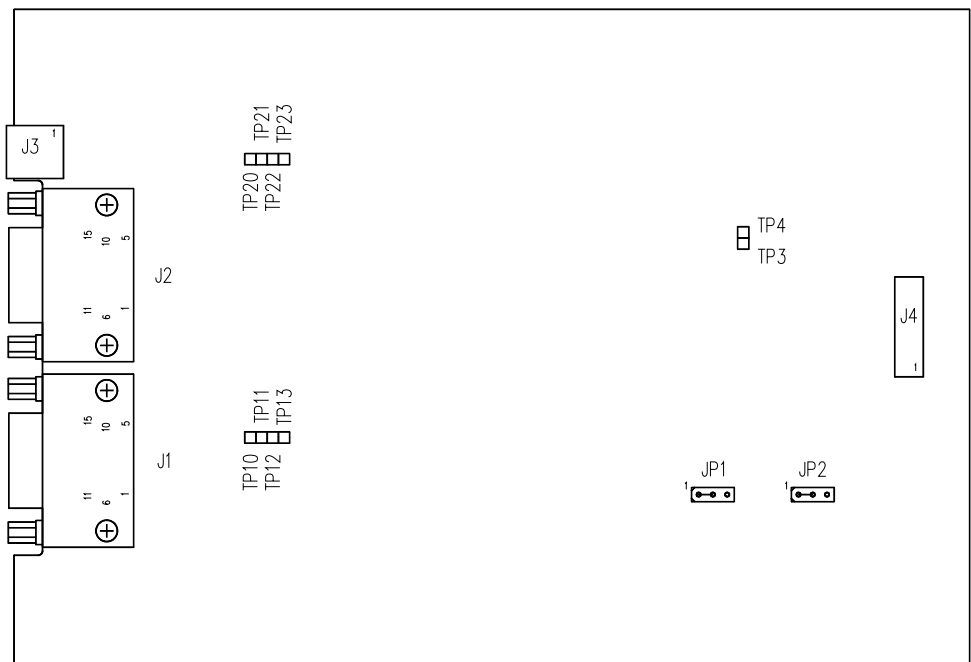
*Figure 4-21. Resolver Option Assembly (690D1599 Rev. 0)***Table 4-23. External Power Pin Assignment (J403)**

Pin #	Label	Description	In/Out
1	+12 VDC	+12 Volts DC	Input
2	-12 VDC	-2 Volts DC	Input
3	Common	Signal Common	N.A

4.4.1. Resolver/Inductosyn Setup

There are three fundamental steps of configuring the RDP option board:

- Configuring the Resolver Hardware
- Configuring the Resolver's Analog Feedback Signals
- Configuring the Commutation Parameters

4.4.1.1. Configuring the Hardware

There is a limited amount of hardware configuration capability on the RDP option board; most capability must be ordered as a factory option. These features include carrier frequency and the number of R/D converter channels, 1 or 2.

NOTE



There are two jumpers located on the RDP board. These are used to select the reference signal for the converter chip (i.e. SIN vs. COS). Jumper JP1 selects the reference for channel 1 and jumper JP2 selects the reference for channel 2.

NOTE: Typically these jumpers only require being changed when inductosyns are used.

The SIN reference is a fixed-phase signal, which is in phase with the reference signal used by the resolver. The COS reference is a variable-phase signal which may be phased shifted with respect to the reference of the resolver/inductosyn to optimize the alignment of the feedback (required for inductosyns, which nominally provide a 90 degree phase shift on feedback; optional for resolvers with significant phase loss). The default phase offset is 90 degrees. For most inductosyns, this value will need to be varied from system to system to optimize performance. See Figure 4-22 below for example phasing.

NOTE



Some Aerotech systems may have an optional pre-amplifier board. This may be installed within the mechanics itself, as is the case with an Aerotech AOM360D optical mount. If so, the first step is to adjust the P1 potentiometer on the pre-amplifier board to equalize the Sine and Cosine feedback signals to the same amplitude.

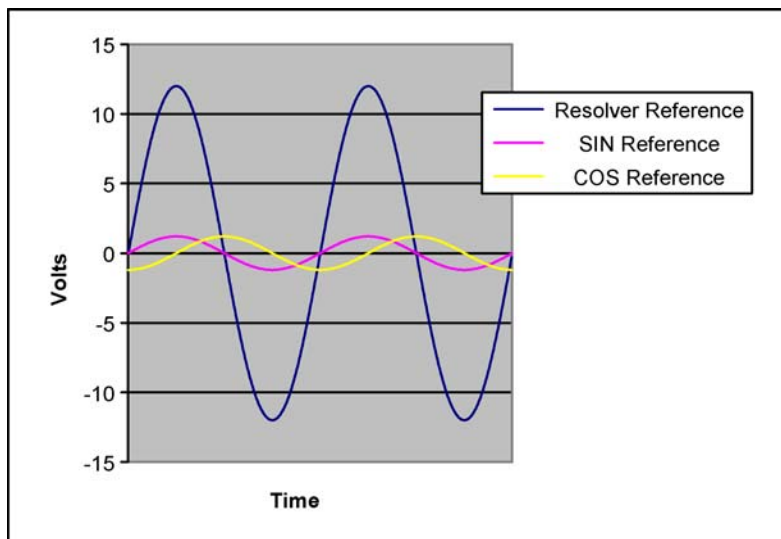

Figure 4-22. Analog Output Connector (TB301)

4.4.1.2. Configuring the Analog Feedback Signals

Using the Encoder Feedback Configuration Utility to set up a resolver/inductosyn

The RDP option of the Ndrive HL can be optimally aligned quickly, using the Encoder Feedback Configuration utility within the NScope.exe utility.

When the Ndrive HL is configured for Resolver Feedback (via the CfgFbkPosType axis parameter), then the currently selected channel (1 or 2, defined via the CfgFbkPosChan axis parameter) of the RDP board will output its analog inputs for SIN/COS into the analog input channels of the Encoder Configuration Feedback utility (a utility also used to configure the -MXH option). The values sampled by the analog inputs reflect the peak value of the carrier-frequency sine waves used by the Resolver to Digital converter.



The Position feedback type, at present, dictates which analog channels are sampled.

There are two axis parameters, which are used to configure the analog feedback from a resolver or inductosyn for optimum performance:

- CfgFbkRDGain defines the peak amplitude of the reference sine wave to the resolver.
- CfgFbkRDCosPhase defines the phase delay on the Cosine phase of the dual-phase oscillator.

When to use the CfgFbkRDCosPhase axis Parameter:

The Cosine reference signal can be adjusted from approximately 0 degrees (i.e. in phase with the SINE reference signal) to 180 degrees, with a nominal value of 90 degrees. This axis parameter is primarily for use with inductosyns, which have a nominal phase shift from the reference signal of 90 degrees. This value may vary from system to system, and therefore can be adjusted to ensure that the alignment of the feedback signals to the reference signal is at its optimum, for better performance.

This signal can also be used to adjust for resolvers that have a large amount of phase lag. Typically, less than 5 degrees of phase lag is acceptable and does not require use of the COS reference.



Use of this axis parameter requires that the jumper on the RDP board for this channel (JP1 for channel 1 or JP2 for channel 2) be set from 2-3 instead of from 1-2. Also, in order for the A/D's to sample properly, the appropriate bit in the CfgFbkRDConfig axis parameter should be set to 1 (bit 0 for channel 1 or bit 1 for channel 2).

For most resolvers, use of the CfgFbkRDCosPhase axis parameter is not required. If this axis parameter is not being used, the jumpers should be set to 1-2 and the bits in the CfgFbkRDConfig axis parameter should be set to 0. Skip to the section on adjusting the R/D Gain.

Adjusting the CfgFbkRDCosPhase axis Parameter:

After starting the Encoder Feedback Configuration utility, make sure the proper axis is selected and then start collecting data continuously. Set the CfgFbkRDGain axis parameter to 0 to minimize the gain. This can be done through the Ndebug.exe utility. Rotate the resolver or inductosyn until the analog signals are at one of the vertical or horizontal lines; this will ease location of a maximum. See Figure 4-23., below, for an example. Adjust the CfgFbkRDCosPhase axis parameter until you locate a local maximum. This can be done through the Ndebug.exe utility. When the maximum has been found, rotate the motor in a complete circle to ensure you see a circle. If not, the P1 amplitude potentiometer on the pre-amplifier board (if present), may need adjusted.

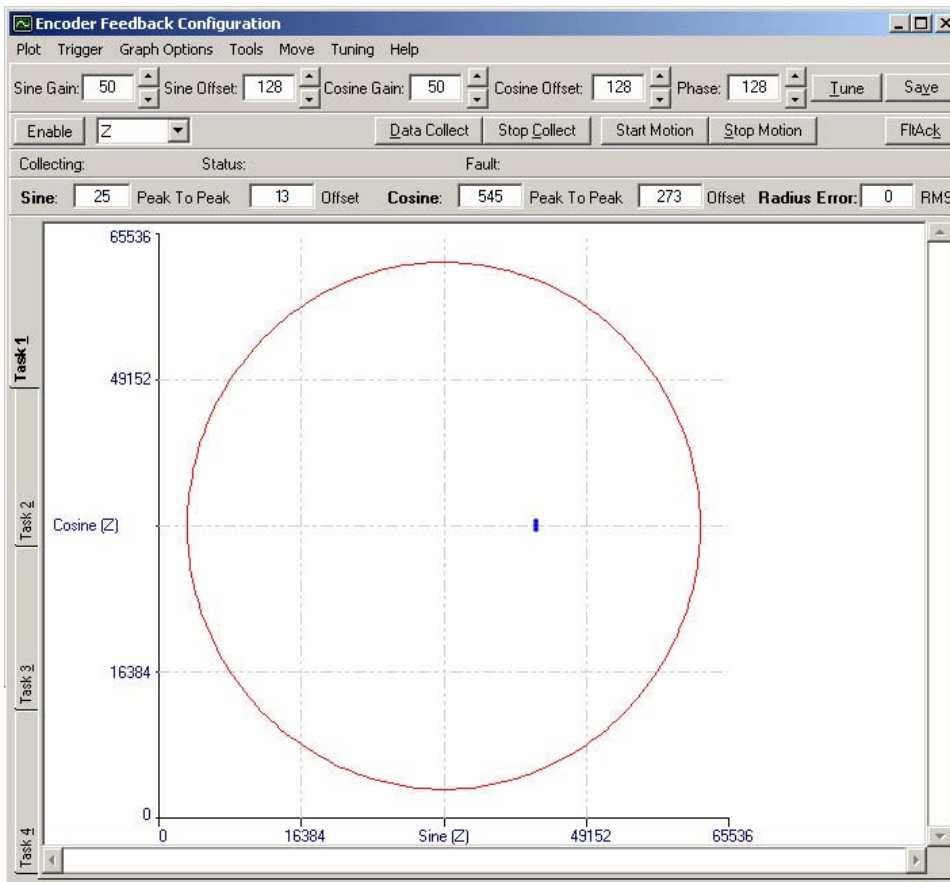

Figure 4-23. Resolver Located at Maximum of SIN Signal

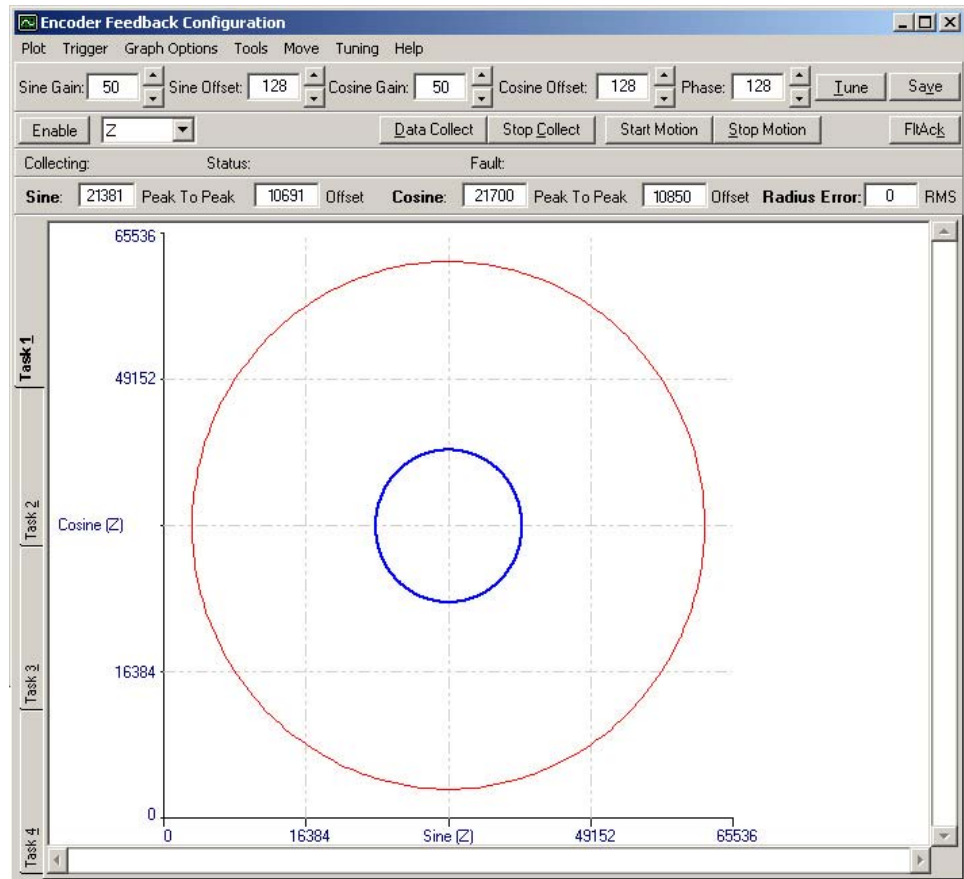

Figure 4-24. Rotating the Resolver (to see a circle)

NOTE



For this to function you **MUST** have the proper jumper set to 2-3 for this channel and the bit in the CfgFbkRDConfig axis parameter set to 1. Otherwise, erratic results may occur.

Adjusting the gain of the R/D converter

Once the phase is adjusted for optimum conversion for inductosyns, adjust the CfgFbkRDGain axis parameter until you see the analog signals peaking between approximately 5,000 (on the low end) and 60,500 (on the high end) counts. This axis parameter can be adjusted via the Ndebug.exe utility. These numbers equate to approximately 0.38 to 4.62 volts on a zero- to 5-volt scale, or ± 8.48 volts on a $\pm 10V$ scale (i.e. via the Nstat.exe utility), depending upon where you measure the signals. This nominally provides 2V RMS (2.83 volts peak) to the converter chip on the RDP option board, which is required for optimum operation. See Figure 4-25. for an example of an optimum circle.

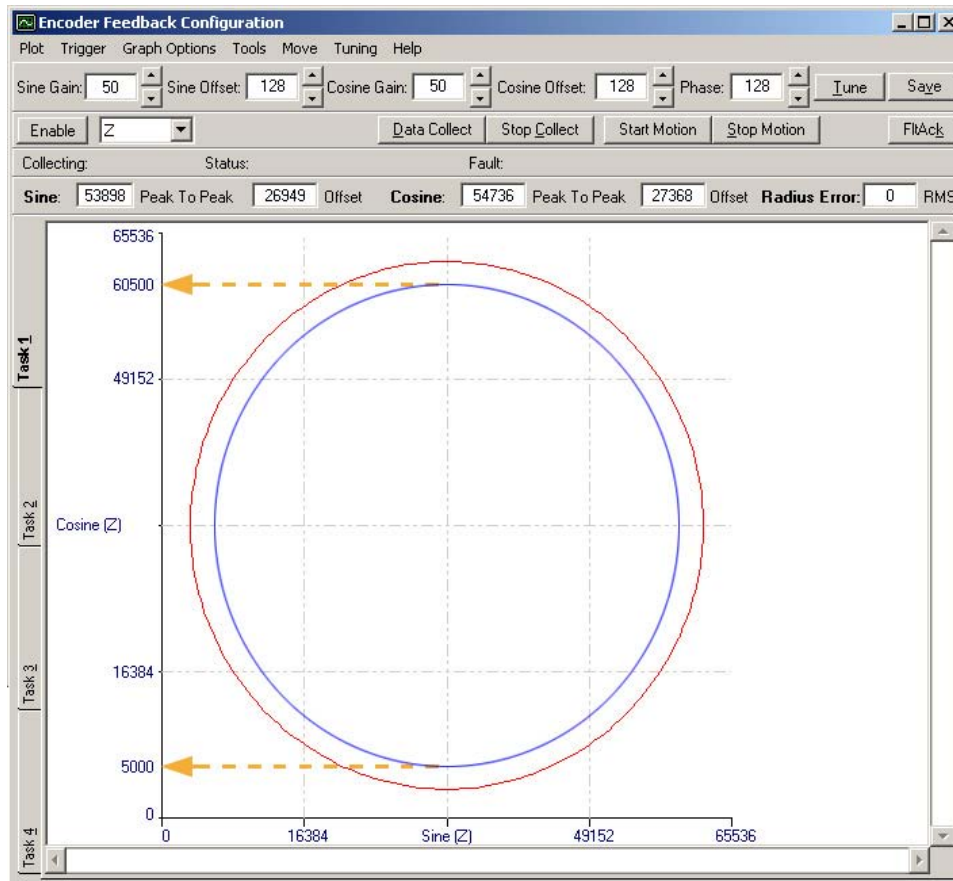



Figure 4-25. Optimized Resolver Feedback Configuration

4.4.1.3. Configuring the Commutation Initialization

The commutation of brushless motors with resolver feedback may be initialized two ways. The first method uses the number of motor pole pairs combined with the maximum resolution of the R/D board to determine an initial commutation position. The second method initializes the motor normally using the Hall effect feedback signals.

<p>NOTE</p> 	<p>Setting the CfgMotType axis parameter to Auto-MSET can be used if the R/D Auto-configuration or Hall effect signals cannot be used.</p>
<p>NOTE</p> 	<p>R/D auto-configuration typically CANNOT be used with inductosyns because they have multiple electrical cycles per revolution of the motor. R/D Auto-configuration will ONLY work if you have EXACTLY one cycle of the Sine and Cosine signals per revolution of the motor.</p>

The Commutation Initialization method of the R/D is specified through bit 8 of the CfgFbkRDConfig axis parameter.

Setting this bit to 1, utilizes Hall-Effect commutation initialization (i.e. commutation is initialized similar to encoder feedback). Note that this requires proper hall-effect to back-EMF configuration and/or proper commutation phase shift axis parameter setting; see brushless motor setup information for more details.

Setting this bit to 0 uses the R/D Auto-Configuration, when the axis is enabled.



The Position feedback type at present dictates which channel is used for commutation initialization. Typical configuration of the R/D has the CfgFbkPosType axis parameter set to 6 and CfgFbkVelType axis parameter set to 0 (use position). If two resolvers or inductosyns are used in dual-loop mode, the position source will generate the commutation initialization but the velocity source will maintain commutation position after enable. Dual-Loop with resolvers and other feedback sources is not advisable.

Finding the Proper Commutation Offset in R/D Auto-Configuration Mode

The R/D Auto-Configuration mode assumes that the zero crossing of the R/D Converter is aligned with the 0 angle of commutation on the Ndrive HL. Therefore, to determine the commutation offset angle, perform the following steps:



The resolver absolute counter may also be read in the Ndebug utility via the command sequence: "DSPMEMREAD 2 0xEB0006" for channel 1, or 0xEB0007 for channel 2.

- 1) Open the Nstat.exe utility.
- 2) Select the tab, which displays the absolute resolver feedback register.
- 3) Rotate the resolver until you have an approximate zero value on the feedback register (note that this value will roll over at 65535).
- 4) Begin with an MSET value of 0 degrees, execute MSET commands with an increasing angle until you see a value of 0 indicated for the absolute resolver angle. This MSET angle is the desired commutation offset.
- 5) Enter the value from step 4 into the CfgMotOffsetAng axis parameter. Note that for negative values, you must add 360 degrees (valid parameter range is 0-360 degrees).

▽ ▽ ▽

CHAPTER 5: ACCESSORIES

5.1. Standard Interconnection Cables

The following three Tables show a summary of the standard cables used for interconnecting various items to the Ndrive HL.



To identify your cable or for a wiring/assembly drawing, see your software CD ROM.

Table 5-1. Standard Interconnection Cables

Cable Part #	Description
C13803-xx	DC Brush Motor Cable (DC MTR & FB-25DU FL-24MS-MAX107DM)
C15291-xx	Encoder Feedback Cable (BL FB-25DU-17MS 9DU-MAX120DM)
C15805-xx	Motor Cable (BL MTR FL 4MS)
C1650X	Encoder Feedback Cable (BL FB-25DU-25DU-MAX120DM)
C1839X	Encoder Feedback Cable (BL FB-25DU-25DU 9DU-MAX120DM)
C18982	Motor and Encoder Feedback Cable (BL MTR&FB-FL-25DU-25DU-107DM MAX)
C19360-xx	Motor Cable (BL MTR-FL-4DU-MAX450DM)
C19791	Joystick Extension Cable with Flying Leads (JSXT-FLY-XX)
C19792	Joystick Extension Cable with D Style Connectors (JSXT-26HD-XX)
C19793	Two-Axis Joystick Adapter Cable (J205 on two Ndrive HLs)
C19794	Two-Axis Joystick Adapter Cable with Flying Leads (J205 and -IO option)
C19851	Hi-Flex Motor Cable (BL MTR-FL-4DU-HF-46DM)
C19891-xx	Auxiliary I/O to SSI Net 1 Cable
C19892-xx	Auxiliary I/O to SSI Net 2 Cable
C20251-xx	Stepper Motor Cable
ECZ01231	BBA32 Interconnect Cable

xx = Length in decimeters

yy = Length in feet

Table 5-2. Combined Motor & Feedback Cables

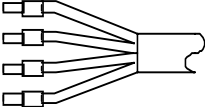
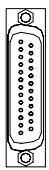
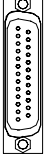
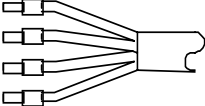
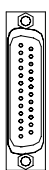
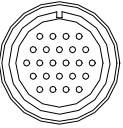
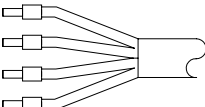
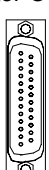
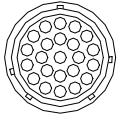
Ndrive HL	Part Number (s)	Description	Stage/Motor
 <p>Motor Output</p>  <p>Motor Feedback</p>	C18982-xx BFMCDNT-yy	BL MTR & FB-25DU FL-25DU-MAX107DM Obsolete	 <p>Motor/Encoder / Limits / Halls</p>
 <p>Motor Output</p>  <p>Motor Feedback</p>	C13803-xx	DC MTR & FB-25DU FL-24MS-MAX107DM	 <p>Motor/Encoder / Limits / Brake</p>
 <p>Motor Output</p>  <p>Motor Feedback</p>	C20251-xx	SM MTR & FB-25DU FL-23B-MAX107DM	 <p>Motor/Encoder / Limits / Brake</p>

xx = Length in decimeters

yy = Length in feet

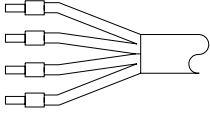
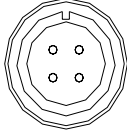
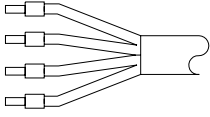
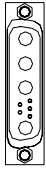
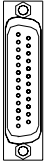
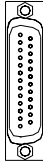
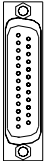
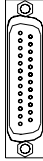
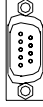
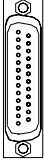
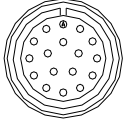

Table 5-3. Individual Motor Cables

Ndrive HL	Part Number (s)	Description	Stage/Motor
 <p data-bbox="232 485 375 510">Motor Output</p>	C15805-xx PMCNT-yy	BL MTR-FL-4MS-MAX450DM Obsolete	 <p data-bbox="1271 495 1336 520">Motor</p>
 <p data-bbox="232 909 375 934">Motor Output</p>	C19360-xx PMCHPDNT-yy	BL MTR-FL-4DU-MAX450DM Obsolete	 <p data-bbox="1271 951 1336 976">Motor</p>

xx = Length in decimeters

yy = Length in feet

Table 5-4. Individual Feedback Cables

Ndrive HL	Part Number (s)	Description	Stage/Motor
 <p>Motor Feedback</p>	C16501-xx C16505-xx BFCMX-yy	BL FB-25DU-25DU-MAX120DM BL FB-25DU-25DU-MAX240DM Obsolete	 <p>Encoder/Limits / Halls / Brake</p>
	<p>Used On: Any brushless motor stage having a 25 pin "D" style connector for encoder, limits, halls and brake. BM/BMS motors (with -D25 option) ABL2000 & 8000 series ABR1000 Series ADR160 - 240 series ADRT series ALA1000 series ALS130, 135, 2200, 3600, 5000, 5000WB, 20000, & 25000 series ARA125 series ASR1000, 1100, & 2000 series (with -HPD option) ATS1100-H series LMA & LMAC series</p>		
 <p>Motor Feedback</p>	C18391-xx C18393-xx BFCD-yy	BL FB-25DU-25DU 9DU-MAX120DM BL FB-25DU-25DU 9DU-MAX240DM Obsolete	 <p>Encoder / Halls / Brake</p>  <p>Limits</p>
	<p>Used On: Any Brushless motor stage having a 25 pin "D" style connector for encoder, halls and brake and a 9 pin "D" connector for limits. BM/BMS motors (with -D25 option)</p>		
 <p>Motor Feedback</p>	C15291-xx C15297-xx BFC-yy	BL FB-25DU-17MS 9DU-MAX120DM BL FB-25DU-17MS 9DU-MAX240DM Obsolete	 <p>Encoder / Halls / Brake</p>  <p>Limits</p>
	<p>Used On: Any stage having a BM/BMS motor with a 17 pin "MS" style connector for encoder, halls and brake and a 9 pin "D" connector for limits.</p>		

xx = Length in decimeters

yy = Length in feet

5.2. Joystick Interface

The user may connect an Aerotech JI (not JBV, or JP4) joystick or their own joystick and switches to the Ndrive HL (Refer to Figure 5-1). The joystick interlock input must be set to the logic low state to indicate the joystick is connected. The zero velocity null-point for each joystick is approximately 2.5 volts. Be sure to set the JoyStickMinVoltage and JoyStickMaxVoltage task parameters. Also, the two potentiometers may be connected to analog inputs on two different Ndrive HLs since each Ndrive HL standardly has one analog input.

Subsequent drawings illustrate how to connect a single axis and a two-axis joystick to the Ndrive HL in various ways, and the cables required to so do. A two-axis joystick requires an Ndrive HL with the -IOPSO option, form two analog inputs or two Ndrive HLs, each with one analog input.

When using an external potentiometer (such as a joystick) to drive the Ndrive HL analog inputs, it must be manually calibrated.

- 1) Set the joystick potentiometer at mid point (detent position) and record the voltage from the Nstat window.
- 2) Record the voltage at the minimum and maximum deflections of the potentiometer. Subtract the two voltages.
- 3) Set the **JoyStickMaxVoltage** task parameter to the mid point voltage from step 1 plus 1/2 the voltage difference from step 2.
- 4) Set the **JoyStickMinVoltage** task parameter to the mid point voltage from step 1 minus 1/2 the voltage difference from step 2.

If two different Ndrive HLs are being used to read the joystick, only one Ndrive HL should be used to provide 5 Volt power to the potentiometers. The second Ndrive HL should connect differentially to the second joystick potentiometer by connecting the Analog Input- to common and the Analog Input+ to the potentiometers wiper.

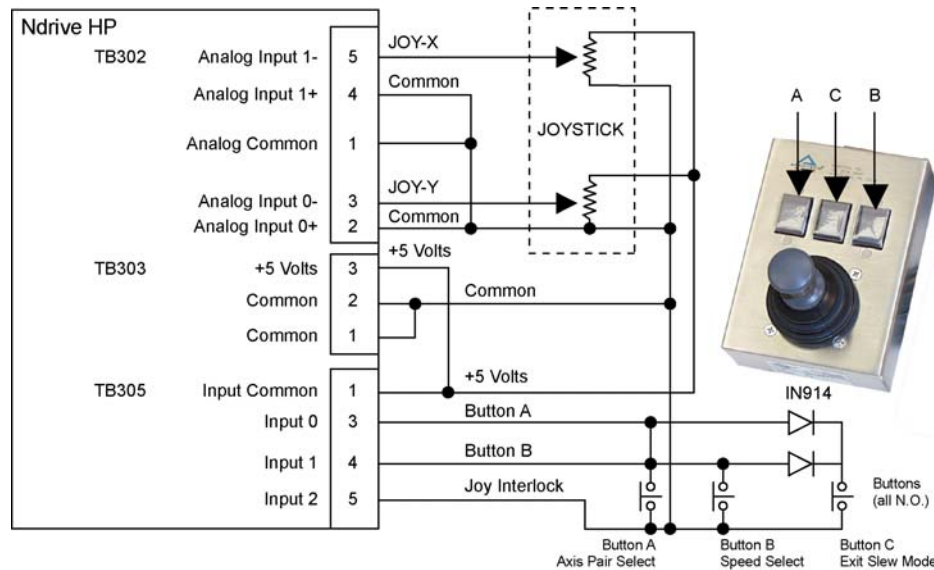

Figure 5-1. Joystick Interface

A standard Aerotech JI joystick may be connected to J205 of the Ndrive HL as a single axis joystick via the following cable, shown below (Figure 5-2 and Figure 5-3). Figure 5-2 indicates the required cable and Figure 5-3 indicates the interconnection of the joystick to the Ndrive HL.

Be sure to set only one of the JoyStickAnalogHorizInput or the JoyStickAnalogVertInput task parameters. Also, define only one axis each of the SlewPair1 through SlewPair8 task parameters.



The following drawings are shown for reference only and were complete and accurate as of this manual's release. The most recent .Dwg files and a viewer may be found on your software CD ROM.

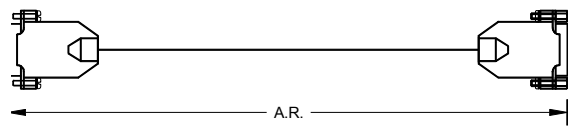
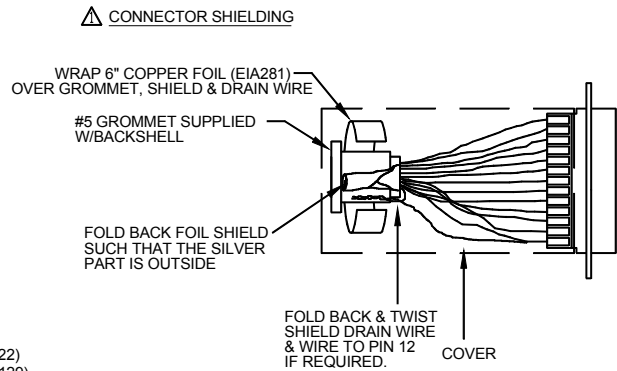
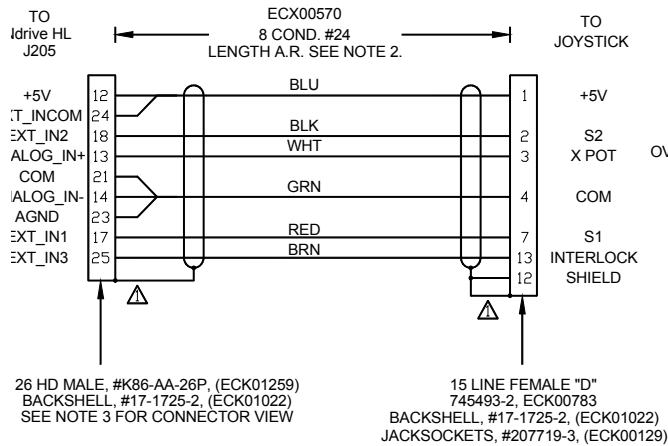

. CABLE LENGTH
CAUTION, CABLE LENGTHS (XX) ARE IN DECIMETERS
EXAMPLE: C19792-30 30 = 30 DECIMETERS (3 METERS) = 10FT.

. CONNECTOR VIEW FROM SOLDER SIDE.

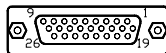

Ndrive HL Joystick
Extension Cable
(JSXT-26HD-XX)

C19792-XX

630B1979-2

630B1979-201.DWG

Figure 5-2. Single Axis Joystick Interface to J205 of the Ndrive HL

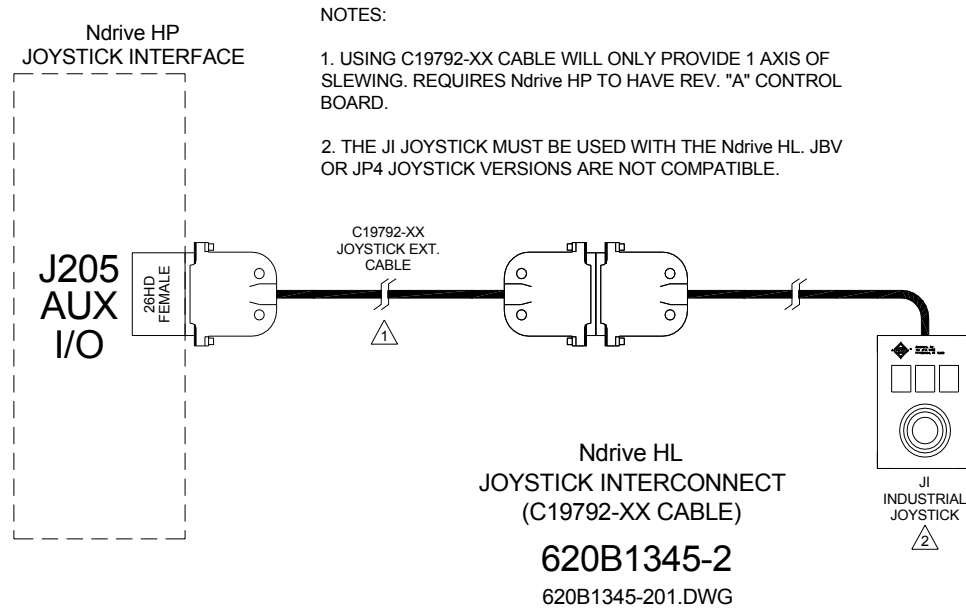

Figure 5-3. Single Axis Joystick Interconnect to J205 of the Ndrive HL

A standard Aerotech JI joystick may be connected to the I/O on the -IOPSO option via the following cable for a two-axis joystick. Figure 5-4 indicates the required cable and the Figure 5-5 indicates the interconnection of the joystick to the Ndrive HL.

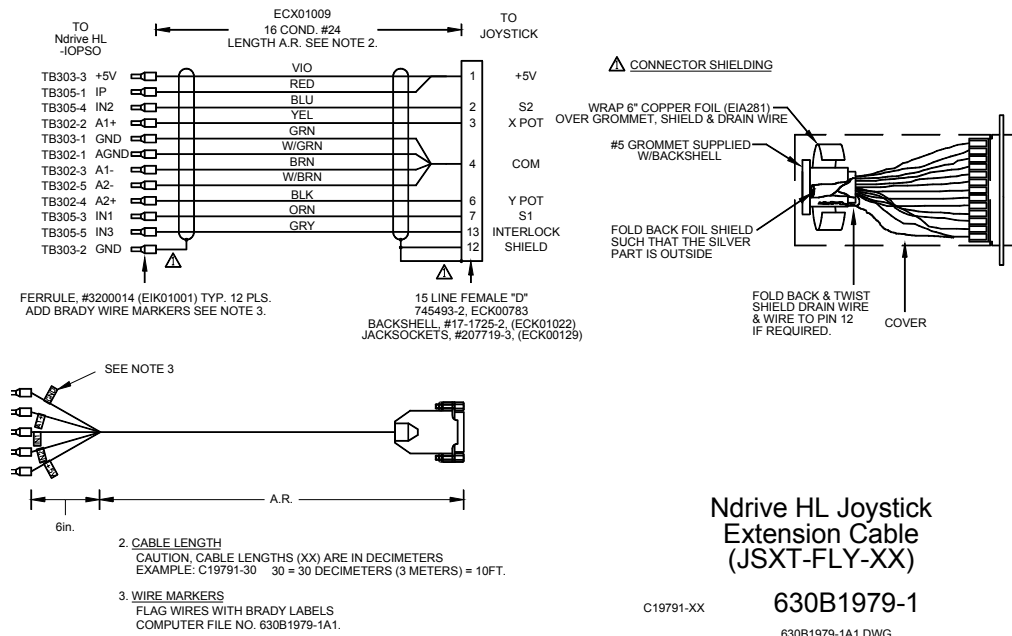

Figure 5-4. Two-Axis Joystick Interface to the I/O on the -IOPSO Option

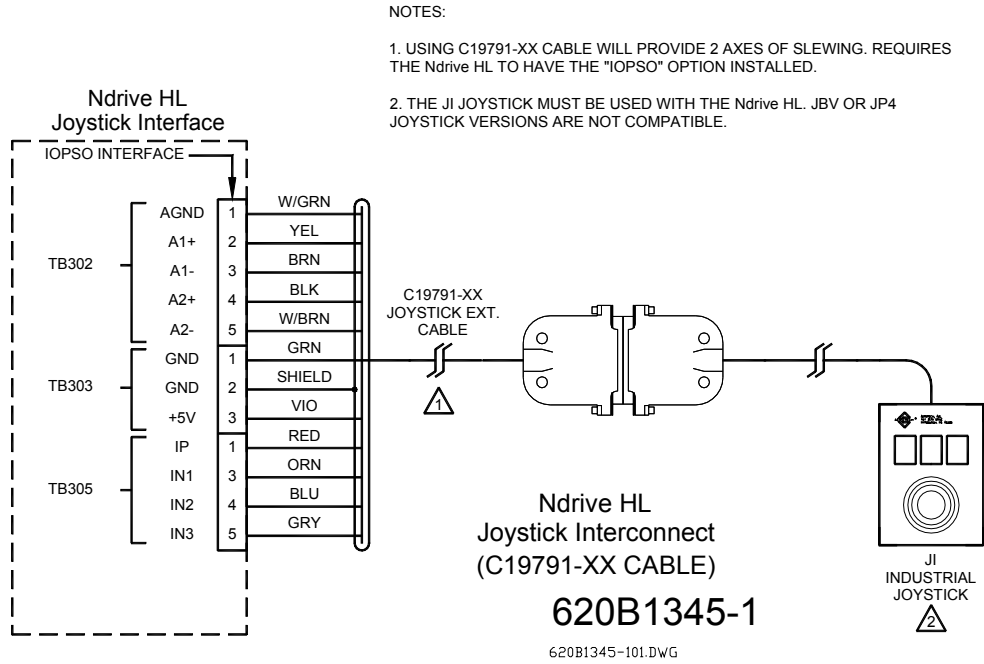

Figure 5-5. Two-Axis Joystick Connection to the I/O on the -IOPSO Option

5.3. Handwheel Interface

The user may connect a handwheel or any device producing differential quadrature signals, for manual positioning of the axes. See the Nview HMI help for information on enabling the handwheel via software commands. The handwheel may be connected to J205 of the Ndrive HL as shown in Figure 5-6 below, or the I/O available on the -IOPSO option, shown in subsequent Figures.

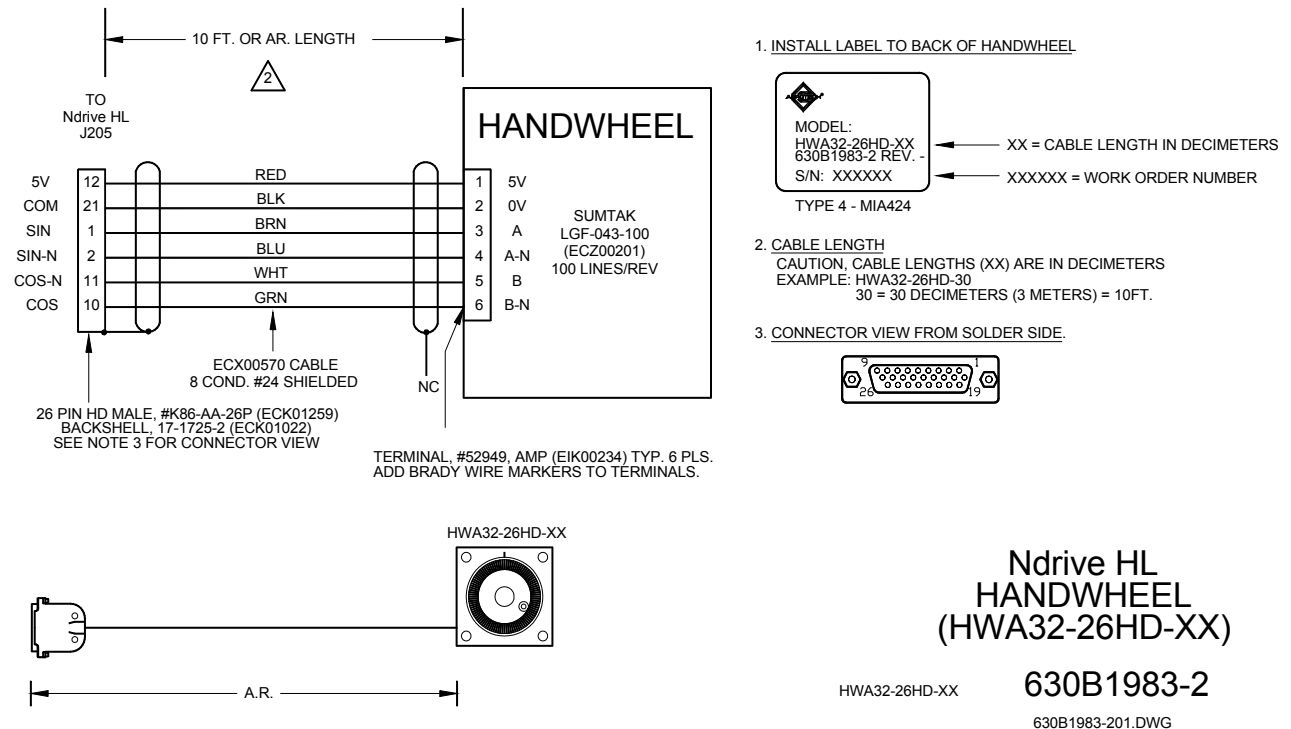

Figure 5-6. Handwheel Interconnection to J205 of the Ndrive HL

A handwheel with flying leads (no connector) may also be connected to the Ndrive HL via the Aerotech BBA32 to J205, per the next two drawings.

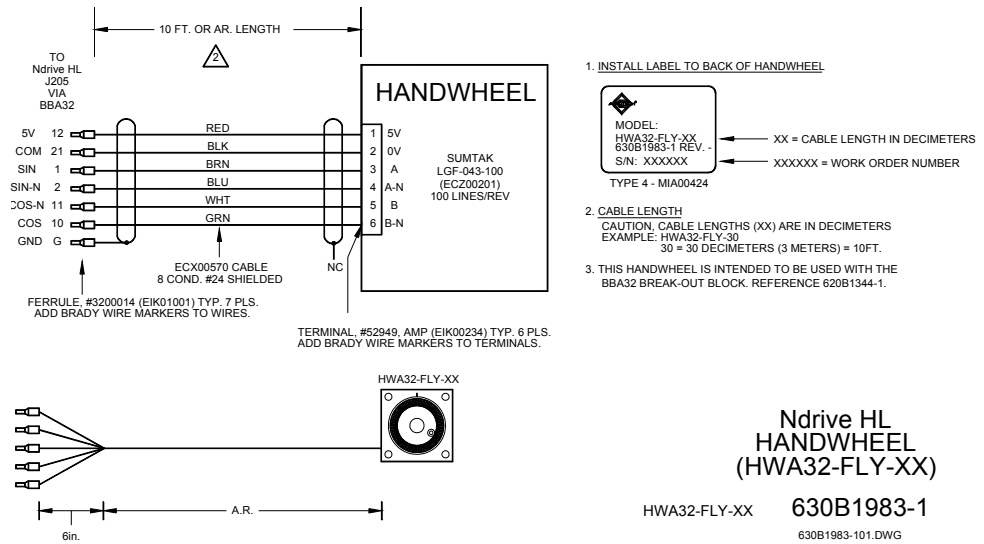

Figure 5-7. Handwheel with Flying Leads (no connector)

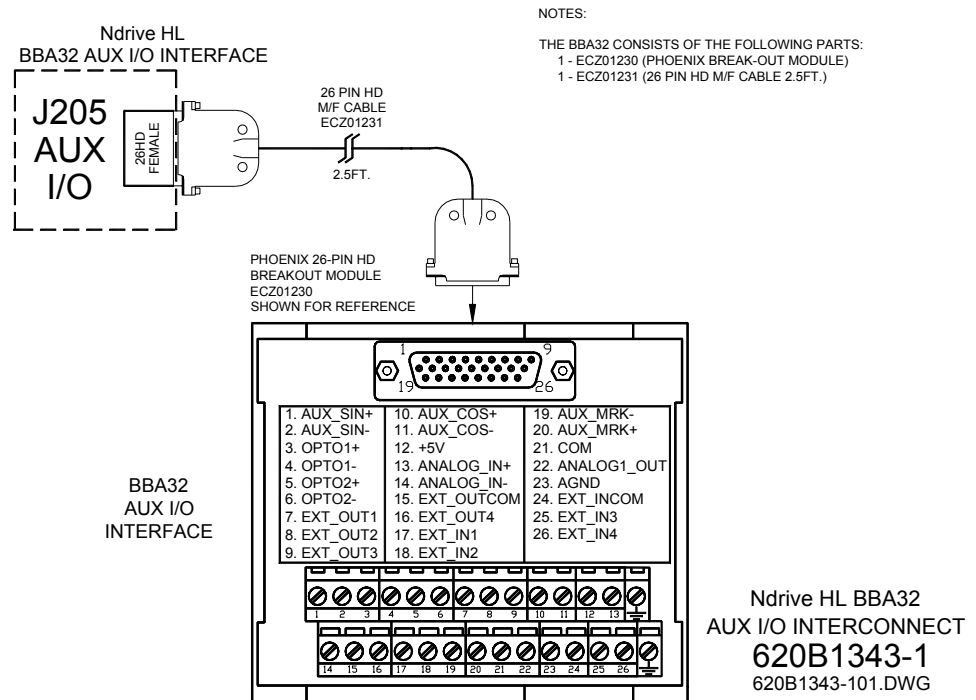

Figure 5-8. BBA32 Interface used to connect a Handwheel with flying leads (no connector)



CHAPTER 6: TROUBLESHOOTING

6.1. Problems, Causes, and Solutions

This section covers symptoms, probable causes, and solutions related to Ndrive HL operation. Table 6-1 lists the most common symptoms of irregular operation and the possible causes and solutions for these faults. More information can be found in the Nview HMI help.



Before performing the tests described in Table 6-1, be aware of **lethal voltages** inside the controller and at the input and output power connections. A qualified service technician or electrician should perform these tests.

Table 6-1. Amplifier Faults, Causes, and Solutions

Symptom	Possible Cause and Solution
Motor spins uncontrollably.	Encoder (sine and cosine) signals are improperly connected. See Section 2.5. for motor phasing information.
Brushless motor will not spin.	Motor phases A, B, and C connected incorrectly relative to Hall A, Hall B, and Hall C inputs. See Section 2.5. for motor phasing information.
Amplifier faults ("ENABLE" LED de-energizes) when the motor decelerates.	Bus over voltage detected (Ndrive HL). This condition indicates an excessive regeneration condition.
Amplifier Faults ("ENABLE" LED de-energizes).	<ol style="list-style-type: none"> 1. RMS current exceeded - run at a lower current. 2. Over temperature condition - Turn off and let amplifier cool down. Provide better ventilation. 3. Defective on board power supply - Return for repair.



6.2. Ndrive HL Control Board Test Points

The following test point is available internal to the Ndrive HL.

Table 6-2. Ndrive HL Control Board Test Point

Test Point	Function
TP4	Signal Common (Analog and Digital)

6.3. Ndrive HL Control Board Assembly

Figure 6-1 highlights the important components located on the control board assembly. The Ndrive HL is jumper selectable, providing the user with quick reconfiguration capability of the few operating modes not configurable by software. Table 6-3 list the jumpers and the default configurations for the Ndrive HL Control board (the -IOPSO option board and jumper configurations are listed in Chapter 4).

S2 defines the Ndrive HL device number and is the only user configured switch/jumper on the control board (see Table 2-5).

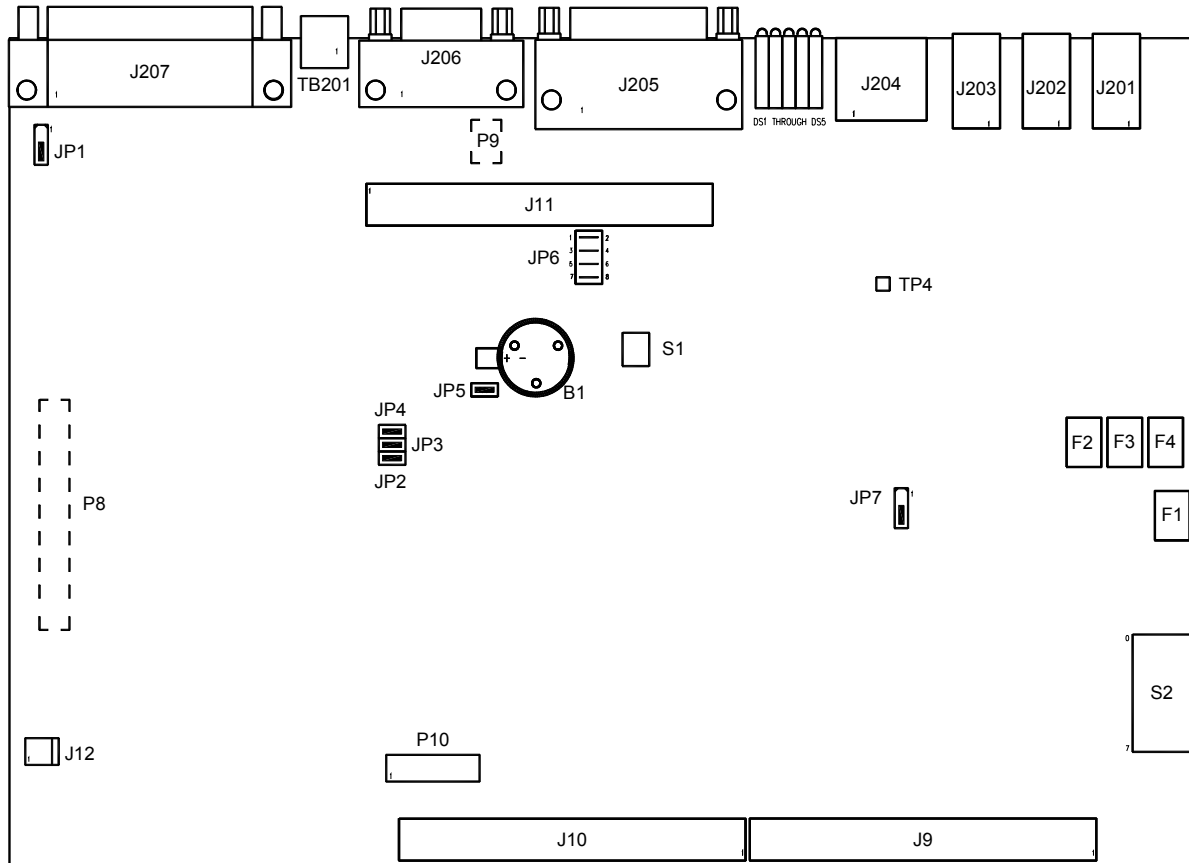

Figure 6-1. Ndrive HL Control Board Assembly (690D1577 Rev. A)

Table 6-3. Ndrive HL Control Board Jumper Selections

Jumpers	Position	Function
JP1	1-2	Signal Common isolated from Frame Ground (Chassis)
	2-3 *	Signal Common connected to Frame Ground (Chassis)
JP2	All in *	Auxiliary Encoder Channel 2 is an input
JP3 JP4	All out	Auxiliary Encoder Channel 2 is an output
JP5	In *	100 Ohm Terminator present for RS-485 port on J301
	Out	100 Ohm Terminator not present for RS-485 port on J301
JP6A	1-2 *	In for 100 Terminator on RS-422 Port 2 (J301, J302, J303)
JP6B	3-4 *	In for 100 Terminator on RS-422 Port 1 (J301, J302, J303)
JP6C	5-6 *	In for 100 Terminator on RS-422 Port 3 (J302, J303)
JP6D	7-8 *	In for 100 Terminator on RS-422 Port 4 (J302, J303)
JP7	1-2	Watch Dog Timer Enabled
	2-3 *	Watch Dog Timer Disabled

* indicates factory default setting



Switch S1 is for factory use only and should not be changed by the user.

The Ndrive HL control board has no user-replaceable fuses.

6.4. Ndrive HL Motor Power Board Assembly

Figure 6-2 highlights the important jumpers and components located on the Ndrive HL power board.



Remove AC power from unit before removing the cover.

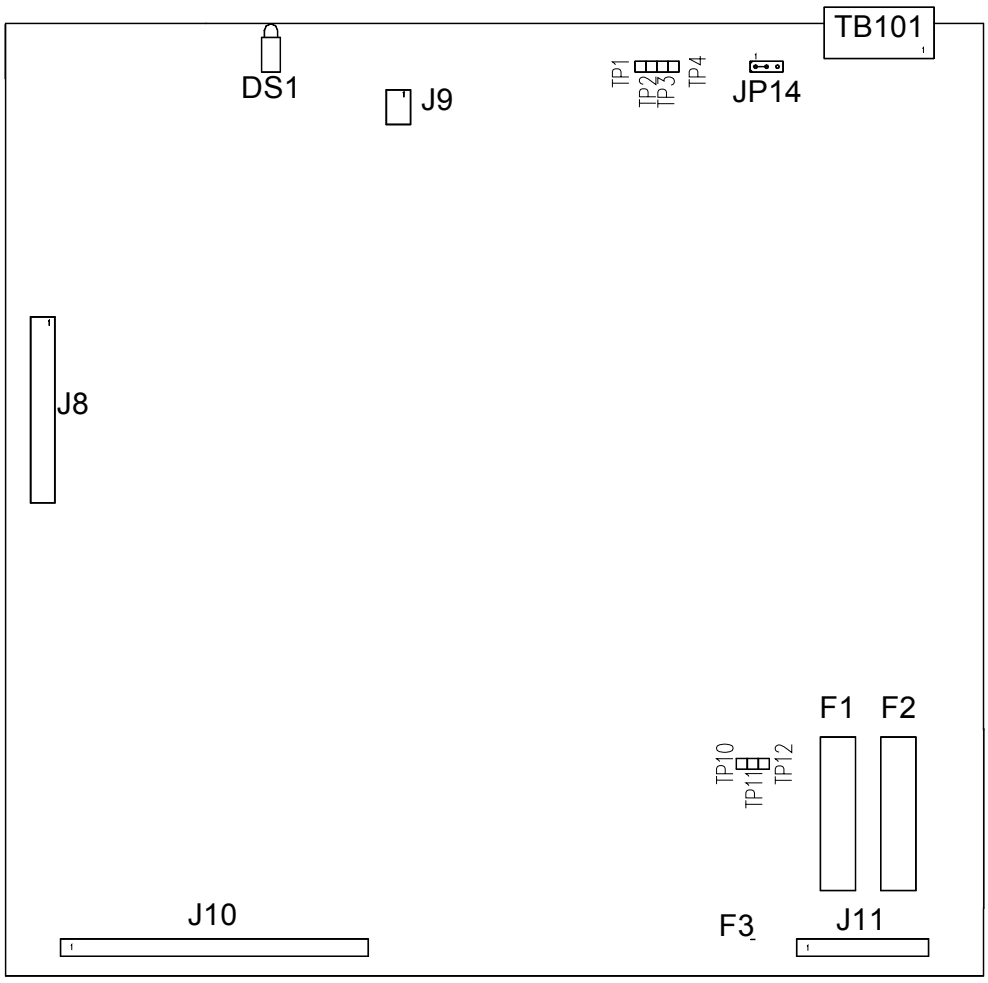

Figure 6-2. Ndrive HL Motor Power Board, (690D1589 Rev 0)

Table 6-4. Ndrive HL Motor Power Board Jumper Selections

Jumper	Selection	Description
JP14	1-2 IN, 2-3 OUT	Signal common connected to chassis (Default)
	1-2 OUT, 2-3 IN	Signal common not connected to chassis

Table 6-5. Ndrive HL Motor Power Board Fuse Information

Fuse	Description	Size
F1, F2	Bus Supply Fuses (Motor Power)	Ndrive HL10-40: 5 A S.B., 3AG
		Ndrive HL20-40: 10 A S.B., 3AG
		Ndrive HL10-80: 5 A S.B., 3AG
F3	+5 Volt Fusing for Power Board	2 A S.B.

Table 6-6. Ndrive HL Motor Power Board Test Point Information

Test Point	Description
TP1	+12V
TP2	-12V
TP3	+5V
TP4	Common
TP10	Phase A Common
TP11	Phase B Common
TP12	Phase C Common

6.5. Ndrive HL Power Supply Board Assembly

Figure 6-3 highlights the important components located on the Ndrive HL Power supply Board. Table 6-4 lists the jumpers and the default configurations for the amplifier.

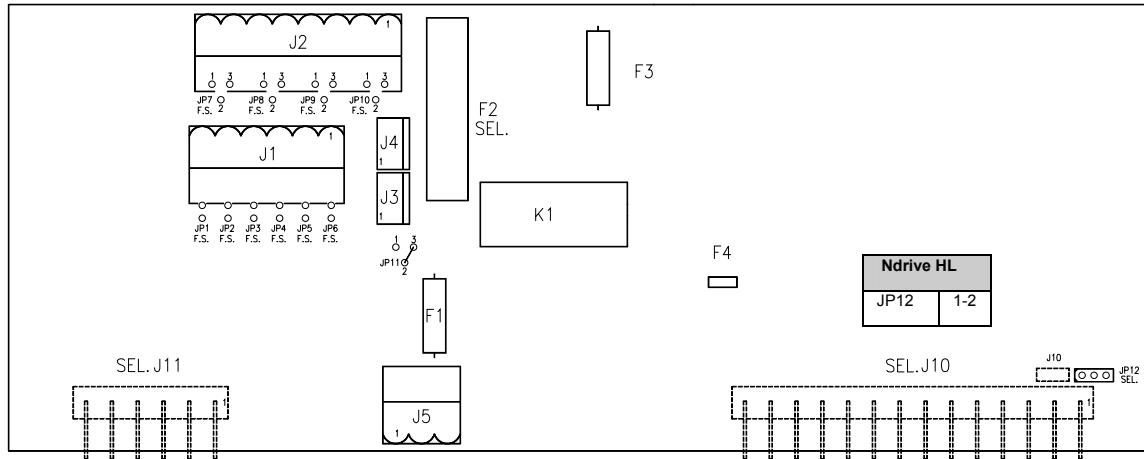

Figure 6-3. Ndrive HL Power Supply Board, (690D1588 Rev -)

Table 6-7. Jumper Selections (Line Voltage) on Power Supply Board

Input Power	JP7	JP8	JP9	JP10	F2 (Fuse)
A (115 V)	1-2	1-2	2-3	2-3	10 ASB
B (230 V)	1-2	1-2	1-2	1-2	5 ASB
C (100 V)	2-3	2-3	2-3	2-3	10 ASB
D (200 V)	2-3	2-3	1-2	1-2	5 ASB

Table 6-8. Jumper Selections (Bus Voltage) on Power Supply Board

Standard Voltage	JP1	JP2	JP3	JP4	JP5	JP6
40 VDC	IN	IN	–	–	IN	IN
80 VDC	–	–	IN	IN	–	–



Remove AC power from the unit before removing the cover.



JP12 must always be set 1-2.

Table 6-9. Ndrive HL Power Supply Board Jumper Selections

Jumpers	Positions	Function
JP5	1-2*	Bus under-voltage detection enabled
	2-3	Bus under-voltage detection disabled
JP6	1-2*	FireWire Bus power source
	2-3	Disable Fire Wire Bus power source

* Factory Default



All jumpers are factory-configured and should not be changed by the user.

Table 6-10. Ndrive HL Power Supply Board Fuse Information

Fuse	Description	Size
F1	AC Control Power Fuse	3A S.B.
F2	See Table Table 6-7.	See Table Table 6-7.
F3	DC Control Power Fuse	.5 A S.B.
R6	AC Inrush Limiter Circuit Fusing	3A S.B.

F2 is a standard socketed fuse. F1, F3 and R6 (Fuse) are soldered to the circuit board. See Section 6.8. for fuse replacement information.

6.6. LED Indicators

The following LEDs are available on each Ndrive HL. Full Ndrive HL status is available via the Nmotion SMC and its utilities.

Table 6-11. LED Indicator Description

Label	Description
LIMIT+	Positive end of travel limit input active
FAULT	An axis fault has occurred, see the Fault axis parameter
POS ERR	Position Error has exceeded the ThresholdPosError axis parameter
ENABLE	Axis is enabled
KERNEL	Nmotion SMC controller is running
LMT-	Negative end of travel limit input active
RMS	RMS motor current has exceeded the ThresholdAvgIAmp axis parameter
CLMT	Current is clamped at the value determined by the ThresholdClampIAmp axis parameter
INPOS	Axis is in position
ACTV	Reset indicator
Active	Axis is enabled
Power	Ndrive HL has control power



6.7. JTAG Programming Connector

This connector is for Aerotech internal use only.

Table 6-12. JTAG Programming Connector – Internal (P10)

Pin #	Label	Description	In/Out/Bi.
1	TDI	JTAG Data Input	Input
2	Common	Signal Common	N.A.
3	TDO	JTAG Data Output	Output
4	Common	Signal Common	N.A.
5	TCK	JTAG Programming Clock	Input
6	Common	Signal Common	N.A.
7	JTAG-TDI	Test Data Input	Input
8	-	Key Position (No Connection)	N.A
9	Reset	Reset	Input
10	TMS	Test Mode Select	Input
11	Power	3.3 Volt Standard (5 Volt Optional)	Output
12	JTAG-TDO	Test Data Output	Output
13	DE-N	Data Enable	Input
14	TRST-N	Test Reset	Input

6.8. Fuse / Battery Replacement

Table 6-14 lists the manufacturer and Aerotech's part number for typical replacement fuses. Additional fuse information can be found on the system drawing supplied with the unit.



Always disconnect the mains power connection before opening the Ndrive HL chassis.

Table 6-13. Ndrive HL Power Supply Board Fuse Information, (690D1588)

Fuse	Description	Third Party P/N	Aerotech P/N	Size
F1	AC Control Power Fuse	Littlefuse 230003S	EIF01013	3A S.B.
F2	-A (115 VAC)	Littlefuse 326010	EIF00117	10 A S.B.
	-B (230 VAC)	Littlefuse 313005	EIF00105	5 A S.B.
	-C (100 VAC)	Littlefuse 326010	EIF00117	10 A S.B.
	-D (200 VAC)	Littlefuse 313005	EIF00105	5 A S.B.
F3	DC Control Power Fuse	Littlefuse 230.500	EIF01010	.5 A S.B.
R6	AC Inrush Limiter Fuse	Littlefuse 230003S	EIF01013	3A S.B.

F2 is a standard socketed fuse. F1, F3 and R6 (Fuse) are soldered to the circuit board.

Table 6-14. Ndrive HL Motor Power Board Fuse Information, (690D1589)

Fuse	Description	Third Party P/N	Aerotech P/N	Size	
F1, F2	Supply main fusing for AC1 VAC bus input	NL10-40	Littlefuse 313005	EIF00105	5 A S.B.
		NL20-40	Littlefuse 326010	EIF00117	10 A S.B.
		NL10-80	Littlefuse 326010	EIF00105	5 A S.B.
F3	+5 Volt Fuse	Littlefuse 0430002	EIF00003	2A S.B.	

F1, F2 are normal, socketed fuses. F3 is soldered to the circuit board.

Table 6-15. Battery Replacement Part Number (Ndrive HL Control Board)

Battery	Description	Third Party P/N	Aerotech P/N
B1	3 V Coin Cell	RAY-O-VAC BR1225	ECZ01079

6.9. Preventative Maintenance

The Ndrive HL and external wiring should be inspected monthly. Inspections may be required at more frequent intervals, depending on the environment and use of the system. Table 6-16 lists the recommended checks that should be made during these inspections.

NOTE



The Ndrive HL (all Aerotech equipment) is not to be used in a manner not specified by Aerotech, Inc.

Table 6-16. Preventative Maintenance

Check	Action to be Taken
Visually Check chassis for loose or damaged parts / hardware. Note: Internal inspection is not required.	Parts should be repaired as required. If internal damage is suspected, these parts should be checked and repairs made if necessary.
Inspect cooling vents.	Remove any accumulated material from vents.
Check for fluids or electrically conductive material exposure.	Any fluids or electrically conductive material must not be permitted to enter the Ndrive HL. Note: Disconnect power to avoid shock hazard.
Visually inspect all cables and connections.	Tighten or re-secure any loose connections. Replace worn or frayed cables. Replace broken connectors.

6.9.1. Cleaning

The Ndrive HL should be wiped with a clean, dry (or slightly damp with water), soft cloth. Fluids and sprays are not recommended because of the chance for internal contamination, which may result in electrical shorts and/or corrosion. The electrical power must be disconnected from the Ndrive HL while cleaning. Do not allow cleaning substances to enter the Ndrive HL or on to any of the connectors. Cleaning labels should be avoided to prevent removal of labels.



APPENDIX A: GLOSSARY of TERMS

Abbe Error	The positioning error resulting from angular motion and an offset between the measuring device and the point of interest.
Abbe Offset	The value of the offset between the measuring device and the point of interest.
Absolute Move	A move referenced to a known point or datum.
Absolute Programming	A positioning coordinate reference where all positions are specified relative to a reference or "home" position.
AC Brushless Servo	A servomotor with stationary windings in the stator assembly and permanent magnet rotor. AC brushless generally refers to a sinusoidally wound motor (such as BM series) to be commutated via sinusoidal current waveform. (see DC brushless servo)
Acceleration	The change in velocity as a function of time.
Accuracy	An absolute measurement defining the difference between actual and commanded position.
Accuracy Grade	In reference to an encoder grating, accuracy grade is the tolerance of the placement of the graduations on the encoder scale.
ASCII	American Standard Code for Information Interchange. This code assigns a number to each numeral and letter of the alphabet. Information can then be transmitted between machines as a series of binary numbers.
Axial Run-Out	Positioning error of the rotary stage in the vertical direction when the tabletop is oriented in the horizontal plane. Axial run-out is defined as the total indicator reading on a spherical ball positioned 50 mm above the tabletop and centered on the axis of rotation.
Axis of Rotation	A centerline about which rotation occurs.
Back EMF, K_{emf}	The voltage generated when a permanent magnet motor is rotated. This voltage is proportional to motor speed and is present whether or not the motor windings are energized.
Backlash	A component of bidirectional repeatability, it is the non-responsiveness of the system load to reversal of input command.
Ball Screw	A precision device for translating rotary motion into linear motion. A lead screw is a low-cost lower performance device performing the same function. Unit consists of an externally threaded screw and an internally threaded ball nut.
Ball Screw Lead	The linear distance a carriage will travel for one revolution of the ball screw (lead screw).
Bandwidth	A measurement, expressed in frequency (hertz), of the range which an amplifier or motor can respond to an input command from DC to -3dB on a frequency sweep.
Baud Rate	The number of bits transmitted per second on a serial communication channel such as RS-232 or modem.

BCD	Binary Coded Decimal - A number system using four bits to represent 0-F (15).
Bearing	A support mechanism allowing relative motion between two surfaces loaded against each other. This can be a rotary ball bearing, linear slide bearing, or air bearing (zero friction).
Bidirectional Repeatability	See Repeatability.
CAM Profile	A technique used to perform nonlinear motion that is electronically similar to the motion achieved with mechanical cams.
Cantilevered Load	A load not symmetrically mounted on a stage.
Closed Loop	A broad term relating to any system where the output is measured and compared to the input. Output is adjusted to reach the desired condition.
CNC	Computer Numerical Control. A computer-based motion control device programmable in numerical word address format.
Coefficient of Friction	Defined as the ratio of the force required to move a given load to the magnitude of that load.
Cogging	Non-uniform angular/linear velocity. Cogging appears as a jerkiness, especially at low speeds, and is due to magnetic poles attracting to steel laminations.
Commutation	The action of steering currents to the proper motor phases to produce optimum motor torque/force. In brush-type motors, commutation is done electromechanically via the brushes and commutator. A brushless motor is electronically commutated using a position feedback device such as an encoder or Hall effect devices. Stepping motors are electronically commutated without feedback in an open-loop fashion.
Commutation, 6-Step	Also referred to as trapezoidal commutation. The process of switching motor phase current based on three Hall effect signals spaced 120 electrical degrees beginning 30 degrees into the electrical cycle. This method is the easiest for commutation of brushless motors.
Commutation, Modified 6-Step	Also referred to as modified sine commutation. The process of switching motor phase current based on three Hall effect signals spaced 120 electrical degrees beginning at 0 electrical degrees. This method is slightly more difficult to implement than standard 6-step, but more closely approximates the motor's back EMF. The result is smoother control and less ripple. Aerotech's BA series self-commutate using this method.
Commutation, Sinusoidal	The process of switching motor phase current based on motor position information, usually from an encoder. In this method, the three phase currents are switched in very small increments that closely resemble the motor's back emf. Sinusoidal commutation requires digital signal processing to convert position information into three-phase current values and, consequently, is most expensive to implement. The result, however, is the best possible control. All Aerotech controllers, as well as the BAS series amplifiers, commutate using this method.

Coordinated Motion	Multi-axis motion where the position of each axis is dependent on the other axis, such that the path and velocity of a move can be accurately controlled. Drawing a circle requires coordinated motion.
Critical Speed	A term used in the specification of a lead screw or ball screw indicating the maximum rotation speed before resonance occurs. This speed limit is a function of the screw diameter, distance between support bearings, and bearing rigidity.
Current Command	Motor driver or amplifier configuration where the input signal is commanding motor current directly, which translates to motor torque/force at the motor output. Brushless motors can be commutated directly from a controller that can output current phase A and B commands.
Current, Peak	An allowable current to run a motor above its rated load, usually during starting conditions. Peak current listed on a data sheet is usually the highest current safely allowed to the motor.
Current, RMS	Root Mean Square. Average of effective currents over an amount of time. This current is calculated based on the load and duty cycle of the application.
Cycle	When motion is repeated (move and dwell) such as repetitive back-and-forth motion.
DC Brushless Servo	A servomotor with stationary windings in the stator assembly and permanent magnet rotor. (See AC Brushless Servo)
Deceleration	The change in velocity as a function of time.
Duty Cycle	For a repetitive cycle, the ratio of on-time to total cycle time used to determine a motor's RMS current and torque/force.
Dwell Time	Time in a cycle at which no motion occurs. Used in the calculation of RMS power.
Efficiency	Ratio of input power vs. output power.
Electronic Gearing	Technique used to electrically simulate mechanical gearing. Causes one closed loop axis to be slaved to another open or closed loop axis with a variable ratio.
Encoder Marker	Once-per-revolution signal provided by some incremental encoders to accurately specify a reference point within that revolution. Also known as Zero Reference Signal or Index Pulse.
Encoder Resolution	Measure of the smallest positional change, which can be detected by the encoder. A 1000-line encoder with a quadrature output will produce 4000 counts per revolution.
Encoder, Incremental	Position encoding device in which the output is a series of pulses relative to the amount of movement.
Feedback	Signal that provides process or loop information such as speed, torque, and position back to the controller to produce a closed-loop system.
Flatness (of travel)	Measure of the vertical deviation of a stage as it travels in a horizontal plane.
Force, Continuous	The value of force that a particular motor can produce in a continuous stall or running (as calculated by the RMS values) condition.

Force, Peak	The maximum value of force that a particular motor can produce. When sizing for a specific application, the peak force is usually that required during acceleration and deceleration of the move profile. The peak force is used in conjunction with the continuous force and duty cycle to calculate the RMS force required by the application.
Friction	The resistance to motion between two surfaces in contact with each other.
G.P.I.B.	A standard protocol, analogous to RS-232, for transmitting digital information. The G.P.I.B. interface (IEEE-488) transmits data in parallel instead of serial format. (See IEEE-488)
Gain	Comparison or ratio of the output signal and the input signal. In general, the higher the system gain, the higher the response.
Grating Period	Actual distance between graduations on an encoder.
Hall Effect Sensors	Feedback device (HED) used in a brushless servo system to provide information for the amplifier to electronically commutate the motor.
HED	Hall Effect Device. (See Hall Effect Sensors)
HMI	Human Machine Interface. Used as a means of getting operator data into the system. (See MMI)
Home	Reference position for all absolute positioning movements. Usually defined by a home limit switch and/or encoder marker.
Home Switch	A sensor used to determine an accurate starting position for the home cycle.
Hysteresis	A component of bidirectional repeatability. Hysteresis is the deviation between actual and commanded position and is created by the elastic forces in the drive systems.
I/O	Input / Output. The reception and transmission of information between control devices using discrete connection points.
IEEE-488	A set of codes and formats to be used by devices connected via a parallel bus system. This standard also defines communication protocols that are necessary for message exchanges, and further defines common commands and characteristics. (See G.P.I.B.)
Incremental Move	A move referenced from its starting point (relative move).
Inertia	The physical property of an object to resist changes in velocity when acted upon by an outside force. Inertia is dependent upon the mass and shape of an object.
Lead Error	The deviation of a lead screw or ball screw from its nominal pitch.
Lead Screw	A device for translating rotary motion into linear motion. Unit consists of an externally threaded screw and an internally threaded carriage (nut). (See Ball Screw)
Life	The minimum rated lifetime of a stage at maximum payload while maintaining positioning specifications.
Limit Switch	A sensor used to determine the end of travel on a linear motion assembly.

Limits	Sensors called limits that alert the control electronics that the physical end of travel is being approached and motion should stop.
Linear Motor	A motor consisting of 2 parts, typically a moving coil and stationary magnet track. When driven with a standard servo amplifier, it creates a thrust force along the longitudinal axis of the magnet track.
Load Carrying Capability	The maximum recommended payload that does not degrade the listed specifications for a mechanical stage.
Master-Slave	Type of coordinated motion control where the master axis position is used to generate one or more slave axis position commands.
MMI	Man Machine Interface used as a means of getting operator data into the system. (See HMI)
Motion Profile	A method of describing a process in terms of velocity, time, and position.
Motor Brush	The conductive element in a DC brush-type motor used to transfer current to the internal windings.
Motor, Brushless	Type of direct current motor that utilizes electronic commutation rather than brushes to transfer current.
Motor, Stepping	Specialized motor that allows discrete positioning without feedback. Used for non-critical, low power applications, since positional information is easily lost if acceleration or velocity limits are exceeded.
NC	Numerical Control. Automated equipment or process used for contouring or positioning. (See CNC). Also, a Normally-Closed switch.
NO	A Normally-Open switch.
NEMA	National Electrical Manufacturer's Association. Sets standards for motors and other industrial electrical equipment.
Non-Volatile Memory	Memory in a system that maintains information when power is removed.
Open Collector	A signal output that is performed with a transistor. Open collector output acts like a switch closure with one end of the switch at circuit common potential and the other end of the switch accessible.
Open Loop	Control circuit that has an input signal only, and thus cannot make any corrections based on external influences.
Operator Interface	Device that allows the operator to communicate with a machine. A keyboard or thumbwheel is used to enter instructions into a machine. (See HMI or MMI)
Optical Encoder	A linear or angular position feedback device using light fringes to develop position information.
Opto-Isolated	System or circuit that transmits signal with no direct electrical connections, using photoelectric coupling between elements.
Orthogonality	The condition of a surface or axis perpendicular (offset 90°) to a second surface or axis. Orthogonality specification refers to the

	error from 90° from which two surfaces of axes are aligned.
Overshoot	In a servo system, referred to the amount of velocity and/or position overrun from the input command. Overshoot is a result of many factors including mechanical structure, tuning gains, servo controller capability, and inertial mismatch.
PID	A group of gain terms in classical control theory (Proportional Integral Derivative) used in compensation of a closed-loop system. The terms are optimally adjusted to have the output response equal the input command. Aerotech controllers utilize the more sophisticated PID FVFA loop which incorporates additional terms for greater system performance.
Pitch (of travel)	Angular motion of a carriage around an axis perpendicular to the motion direction and perpendicular to the yaw axis.
Pitch Error	Positioning error resulting from a pitching motion.
PLC	Programmable Logic Controller. A programmable device that utilizes "ladder logic" to control a number of input and output discrete devices.
PWM	Pulse Width Modulation. Switch-mode technique used in amplifiers and drivers to control motor current. The output voltage is constant and switched at the bus value (160 VDC with a 115 VAC input line).
Quadrature	Refers to the property of position transducers that allows them to detect direction of motion using the phase relationship of two signal channels. A 1000-line encoder will yield 4000 counts via quadrature.
Radial Run-Out	Positioning error of the rotary stage in the horizontal direction when the tabletop is oriented in the horizontal plane. Radial run-out is defined as the total indicator reading on a spherical ball positioned 50 mm above the tabletop and centered on the axis of rotation.
Ramp Time	Time it takes to accelerate from one velocity to another.
Range	The maximum allowable travel of a positioning stage.
RDC	Resolver to Digital Converter. Electronic component that converts the analog signals from a resolver (transmitter type) into a digital word representing angular position.
Repeatability	The maximum deviation from the mean (each side) when repeatedly approaching a position. Unidirectional repeatability refers to the value established by moving toward a position in the same direction. Bidirectional repeatability refers to the value established by moving toward a position in the same or opposite direction.
Resolution	The smallest change in distance that a device can measure.
Retro-reflector	An optical element with the property that an input light beam is reflected and returns along the same angle as the input beam. Used with laser interferometers.
Roll (of travel)	Angular motion of a carriage around an axis parallel to the motion direction and perpendicular to the yaw axis.
Roll Error	Positioning error resulting from a roll motion.

Rotor	The rotating part of a magnetic structure. In a motor, the rotor is connected to the motor shaft.
RS-232C	Industry standard for sending signals utilizing a single-ended driver/receiver circuit. As such, the maximum distance is limited based on the baud rate setting but is typically 50-100 feet. This standard defines pin assignments, handshaking, and signal levels for receiving and sending devices.
RS-274	Industry standard programming language. Also referred to as G-code machine programming. A command set specific for the machine tool industry that defines geometric moves.
RS-422	Industry communication standard for sending signals over distances up to 4000 feet. Standard line driver encoder interfaces utilize RS-422 because of the noise immunity.
Run-Out	The deviation from the desired form of a surface during full rotation (360 degrees) about an axis. Run-out is measured as total indicated reading (TIR). For a rotary stage, axis run-out refers to the deviation of the axis of rotation from the theoretical axis of rotation.
Servo System	Refers to a closed loop control system where a command is issued for a change in position and the change is then verified via a feedback system.
Settling Time	Time required for a motion system to cease motion once the command for motion has ended.
Shaft Radial Load	Maximum radial load that can be applied to the end of the motor shaft at maximum motor speed.
Shaft Run-Out	Deviation from straight-line travel.
Slot-less	Describes the type of laminations used in a motor that eliminates cogging torque due to magnetic attraction of the rotor to the stator slots.
Stator	Non-rotating part of a magnetic structure. In a motor, the stator usually contains the mounting surface, bearings, and non-rotating windings.
Stiction	Friction encountered when accelerating an object from a stationary position. Static friction is always greater than moving friction, and limits the smallest possible increment of movement.
Straightness of Travel	Measure of the side-to-side deviation of a stage as it travels in a horizontal plane.
Torque	Rotary equivalent to force. Equal to the product of the force perpendicular to the radius of motion and distance from the center of rotation to the point where the force is applied.
Torque, Continuous	Torque needed to drive a load over a continuous time.
Torque, Peak	Maximum amount of torque a motor can deliver when the highest allowable peak currents are applied.
Torque, RMS	Root Mean Square is a mathematical method to determine a steadfast or average torque for a motor.
Torque, Stall	The maximum torque without burning out the motor.
Total Indicated Reading	The full indicator reading observed when a dial indicator is in

(TIR)	contact with the part surface during one full revolution of the part about its axis of rotation.
Tuning	In a servo system, the process of optimizing loop gains (usually PID terms) to achieve the desired response from a stage or mechanism from an input command.
Unidirectional Repeatability	See Repeatability
Velocity Command	Motor driver or amplifier configuration where the input signal is commanding motor velocity. Motors with analog tachometers are normally driven by this driver configuration.
Wobble	An irregular, non-repeatable rocking or staggering motion of the table top of a rotary stage. Wobble is defined as an angular error between the actual axis of rotation and the theoretical axis of rotation.
Yaw (of travel)	Rotation about the vertical axis, perpendicular to the axis of travel. Angular movement (error) that affects straightness and positioning accuracy.
Yaw Error	Positioning error resulting from a yaw motion.

▽ ▽ ▽

APPENDIX B: WARRANTY and FIELD SERVICE

Aerotech, Inc. warrants its products to be free from defects caused by faulty materials or poor workmanship for a minimum period of one year from date of shipment from Aerotech. Aerotech's liability is limited to replacing, repairing or issuing credit, at its option, for any products that are returned by the original purchaser during the warranty period. Aerotech makes no warranty that its products are fit for the use or purpose to which they may be put by the buyer, where or not such use or purpose has been disclosed to Aerotech in specifications or drawings previously or subsequently provided, or whether or not Aerotech's products are specifically designed and/or manufactured for buyer's use or purpose. Aerotech's liability or any claim for loss or damage arising out of the sale, resale or use of any of its products shall in no event exceed the selling price of the unit.

Aerotech, Inc. warrants its laser products to the original purchaser for a minimum period of one year from date of shipment. This warranty covers defects in workmanship and material and is voided for all laser power supplies, plasma tubes and laser systems subject to electrical or physical abuse, tampering (such as opening the housing or removal of the serial tag) or improper operation as determined by Aerotech. This warranty is also voided for failure to comply with Aerotech's return procedures.

Laser Products

Claims for shipment damage (evident or concealed) must be filed with the carrier by the buyer. Aerotech must be notified within (30) days of shipment of incorrect materials. No product may be returned, whether in warranty or out of warranty, without first obtaining approval from Aerotech. No credit will be given nor repairs made for products returned without such approval. Any returned product(s) must be accompanied by a return authorization number. The return authorization number may be obtained by calling an Aerotech service center. Products must be returned, prepaid, to an Aerotech service center (no C.O.D. or Collect Freight accepted). The status of any product returned later than (30) days after the issuance of a return authorization number will be subject to review.

Return Procedure

After Aerotech's examination, warranty or out-of-warranty status will be determined. If upon Aerotech's examination a warranted defect exists, then the product(s) will be repaired at no charge and shipped, prepaid, back to the buyer. If the buyer desires an airfreight return, the product(s) will be shipped collect. Warranty repairs do not extend the original warranty period.

Returned Product Warranty Determination

After Aerotech's examination, the buyer shall be notified of the repair cost. At such time, the buyer must issue a valid purchase order to cover the cost of the repair and freight, or authorize the product(s) to be shipped back as is, at the buyer's expense. Failure to obtain a purchase order number or approval within (30) days of notification will result in the product(s) being returned as is, at the buyer's expense. Repair work is warranted for (90) days from date of shipment. Replacement components are warranted for one year from date of shipment.

Returned Product Non-warranty Determination

At times, the buyer may desire to expedite a repair. Regardless of warranty or out-of-warranty status, the buyer must issue a valid purchase order to cover the added rush service cost. Rush service is subject to Aerotech's approval.

Rush Service

On-site Warranty Repair If an Aerotech product cannot be made functional by telephone assistance or by sending and having the customer install replacement parts, and cannot be returned to the Aerotech service center for repair, and if Aerotech determines the problem could be warranty-related, then the following policy applies:

Aerotech will provide an on-site field service representative in a reasonable amount of time, provided that the customer issues a valid purchase order to Aerotech covering all transportation and subsistence costs. For warranty field repairs, the customer will not be charged for the cost of labor and material. If service is rendered at times other than normal work periods, then special service rates apply.

If during the on-site repair it is determined the problem is not warranty related, then the terms and conditions stated in the following "On-Site Non-Warranty Repair" section apply.

On-site Non-warranty Repair If any Aerotech product cannot be made functional by telephone assistance or purchased replacement parts, and cannot be returned to the Aerotech service center for repair, then the following field service policy applies:

Aerotech will provide an on-site field service representative in a reasonable amount of time, provided that the customer issues a valid purchase order to Aerotech covering all transportation and subsistence costs and the prevailing labor cost, including travel time, necessary to complete the repair.

Company Address	Aerotech, Inc.	Phone: (412) 963-7470
	101 Zeta Drive	Fax: (412) 963-7459
	Pittsburgh, PA	
	15238-2897	



APPENDIX C: MANUAL UPDATES

C.1. Current Changes

Version	Change	Sections Updated/Affected
1.08	Removed MXU option For Aerotech Use: Issue Tracker ID 538	All
	Updated motor wiring color codes For Aerotech Use: Issue Tracker ID 730	Section 2.4
	Added -IOPSOH option	Section 4.1
	Updated PSO schematic	Figure 4-15
	Updated Interconnection Cable Part Numbers	Table 5-1
1.08b	Updated Analog Input schematic and Text	Figure 4-9 and Page 4-9

C.2. Archive of Changes

Version	Reason	Sections Updated/Affected
1.07	Corrected typo. in Brake circuit.	Fig. 4-4
	Added notes to Brake section.	Section 4.1.3.
1.06	Updated product name and pictures to new product color.	
1.05	All changes made for Version 1.5 were typographic only.	
1.04	Line Voltage Jumpers	Table 6-5
	Fuse Information	Tables 6-6, 6-7, 6-9, 6-12 & 6-13
1.03	Power board Fuse Value (F1 and F2)	Ndrive HL 10-40: 5A S.B.
		Ndrive HL 20-40: 10A S.B.
		Ndrive HL 10-80: 5A S.B.

INDEX

- <
- < 70 VAC AC Bus Input Power, 2-2
- 1**
- 10/100BASE-T Ethernet, 1-5, 4-22
- 4**
- 4N33, 4-15
- 6**
- 6N136, 4-15
- A**
- AC Power Connections, 2-2
- AL1, 2-2
- AL2, 2-2
- Amplifier Current Limitations, 1-8
- Amplifier Faults, 6-1
- Amplifier Related Problems, 6-1
- Analog Inputs (TB302), 4-9
- Analog Output Connector Pinouts, 4-3
- Auxiliary I/O
- Connector Pinouts, 3-1, 3-3, 3-5, 3-6
 - AUXPWR, 1-5
 - AUXPWR Option, 2-2
- B**
- Battery, 6-9
- Battery Replacement, 6-9
- Brake / Relay (TB301) Current Specifications, 4-4
- Brake / Relay (TB301) Voltage Specifications, 4-4
- Brake / Relay Connector Pinouts, 4-5
- Brake Configuration Jumpers, 4-3
- Brushless Motor Configuration, 2-7, 2-9, 2-10
- Bus Power Supply, 1-4
- C**
- Cleaning, 6-10
- Connector, 1-3
- Connector Pinouts
- Auxiliary I/O, 3-1, 3-3, 3-5, 3-6
 - FireWire, 3-23
 - J205, 3-1, 3-3, 3-5, 3-6
 - J206, 3-21
 - J207, 3-12, 3-14, 3-15
 - Motor Feedback, 3-12, 3-14, 3-15
 - RS-232/RS-422, 3-21
- Continuous Output Current, 1-5
- Control Board, 6-2
- Assembly, 6-2
 - Jumpers, 6-2, 6-3
 - Test Points, 6-2
- Control Board Options, 1-5
- DUALPSO, 1-5
 - ENET, 1-5
 - MXH, 1-5
 - MXU4096, 1-5
 - MXU65536, 1-5
 - PSOOPTO1, 1-5
 - PSOOPTO2, 1-5
 - PSOOPTO3, 1-5
 - TRIPLEPSO, 1-5
- D**
- DC Brush Motor Configuration, 2-7
- Determining Proper Connections to the NDrive
- Equipment, 2-12
 - Test, 2-12
- Device Settings, 2-19
- Drive Package, 1-4
- DUALPSO, 1-5
- E**
- Electrical Specifications, 1-6
- Encoder Phasing, 2-16
- ENET, 1-5, 4-22
- Environmental Specifications
- Humidity, 1-10
 - Temperature, 1-10
 - Operating, 1-10
 - Storage, 1-10
- Ethernet (J204), 4-22
- F**
- Feedback Connections, 2-4, 2-7, 2-11, 2-18
- Field Service Information, C-1
- FireWire, 2-22, 3-23
- Card and Cable Part Numbers, 2-20
 - Connector Pinouts, 3-23
 - J201, 2-22, 3-23
 - J202, 2-22, 3-23
 - J203, 2-22, 3-23

- Minimizing Cable Lengths, 2-21
- Part Numbers, 2-20
- Preferred Configuration, 2-21
- FireWire Bus, 2-22, 3-23
- FireWire:, 2-21
- Fuse Replacement, 6-9

H

- Handwheel Interface, 5-9
- Hardware Function, 1-3
- Hardware Overview, 1-3
- HCPL-2601, 4-15
- High Inrush Currents, 1-4

I

- Input Power, 1-3
 - L1, L2, L3, 2-3
 - Main Supply, 2-3
 - Motor Frame Connections, 2-3, 2-4
 - Shield Connection, 2-3, 2-4
 - TB101, 2-3
- Integrated, 2-4, 2-7
- Integrated Configurations, 2-4, 2-7, 2-11, 2-18
- IOPSO, 1-5, 4-11
- IOPSO# option, 1-3
- IOPSO# Option
 - Jumpers, 5-1
- IOPSO# Option Board
 - Analog Inputs (TB302), 4-9
 - Analog Outputs, 4-3
 - Opto-Isolated Inputs (TB305), 4-12
 - PSO / Absolute Encoder Interface (J301), 4-14
- IOPSO2, 4-11
- IOPSO3, 4-11
- IOPSO4, 4-11

J

- J201
 - FireWire, 2-22, 3-23
- J202
 - FireWire, 2-22, 3-23
- J203
 - FireWire, 2-22, 3-23
- J204, 4-22
- J205
 - Connector Pinouts, 3-1, 3-3, 3-5, 3-6
- J206
 - Connector Pinouts, 3-21
- J206, 3-21
- J207, 3-12, 4-3
 - Connector Pinouts, 3-12, 3-14, 3-15
- J301, 4-14

- Joystick Interface, 5-1, 5-5
- JTAG, 6-8
- JTAG Programming Connector, 6-8
- Jumper Locations
 - Power Board, 6-5
- Jumpers
 - Control Board, 6-3
 - IOPSO#, 5-1
 - Power Board, 6-6

L

- AC1 Input Terminal, 2-3
- AC2 Input Terminal, 2-3
- Laser Output Opto-Isolator Specifications, 3-7, 4-15, 4-20
- LED indicator, 1-3
- LED Indicators
 - Description, 6-7
- Limit and Hall Effect Inputs, 3-14
- Line Driver Encoder (Standard), 3-16
- Logic High, 2-10
- Logic Low, 2-10

M

- Models, 1-5
- Motor, 1-3
- Motor and Feedback Connection Basic
 - Configurations, 2-7
 - Brushless, 2-7
 - DC Brush, 2-7
 - Stepper, 2-7
- Motor and Feedback Connections, 2-4, 2-7, 2-11, 2-18
- Motor Connections, 2-2, 2-4, 2-7, 2-11, 2-18
- Motor Feedback
 - Connector Pinouts, 3-12, 3-14, 3-15
- Motor Feedback, 3-12
 - MXH, 3-12
- Motor Feedback
 - Connector, 4-3
- Motor Frame Connection, 2-3, 2-4
- Motor Phasing, 2-14, 2-15
- MXH, 1-5
- MXH Option
 - Specifications, 3-18
 - Clock Frequency, 3-18
 - Interpolation, 3-18
 - Max Input Frequency, 3-18
 - Minimum Edge Separation, 3-18
 - Minimum Pulse Width, 3-18
- MXH, 3-12
 - Options, 3-17
- MXH Analog Encoder Interface (Optional), 3-15, 3-16

N

Ndrive Connection Test, 2-12
Ndrive Hardware, 1-3

O

Optional AC Power Supply Input, 2-2
Optional Analog Input Connector Pinouts,
4-9
Options, 1-5
Opto-Isolated Input Connector
Pinouts, 4-12
Opto-Isolated Inputs (TB305), 4-12
Opto-Isolated Output Connector
Current Sinking Mode, 4-11
Current Sourcing Mode, 4-11
Output Current, Peak, 1-5

P

P10, 6-8
Part Numbers
FireWire Card and Cables, 2-20
Phase/Hall Sequence, 2-12
Pinouts
Analog Output Connector, 4-3
Brake / Relay Connector, 4-5
Optional Analog Input Connector, 4-9
Opto-Isolated Input Connector, 4-12
PSO / Absolute Encoder Interface (J301),
4-14
SSINet (J302, J303), 4-17
User Power Connector, 4-10
Power, 1-5
Power Board, 6-4
Assembly, 6-4
Bus Voltage Jumper Selections, 6-5
Jumpers, 6-6
Line Voltage Jumper Selections, 6-5
Power Board Assembly, 6-5
Power Board Jumper Locations, 6-5
Power Board Options
-AUXPWR (Auxiliary Power), 1-5
Power Connections, 1-3, 2-2
Preventative Maintenance, 6-10
Product Overview, 1-2
PSO / Absolute Encoder Interface (J301), 4-
14
PSO / Absolute Encoder Interface (J301)
Pinouts, 4-14
PSO Connection, 1-3
-PSOOPTO1, 1-5, 4-15
-PSOOPTO2, 1-5, 4-15
-PSOOPTO3, 1-5, 4-15
-PSOOPTO4, 4-15

R

Relay K1 Contact Ratings, 4-4
RS-232 Connector, 1-3
RS-232/RS-422, 3-21
Connector Pinouts, 3-21

S

S2
Switch Settings, 2-19
Safety Procedures, 2-1
Shield Connection, 2-3, 2-4
Soft Start Circuit, 1-4
SSINet (J302, J303)
Pinouts, 4-17
Standard Encoder Input, 3-16
Standard Package, 1-4
Stepper Motor Configuration, 2-7, 2-14
Switch S2, 2-19

T

Tachometer connection, 2-8
TB101, 2-2
AL1, 2-2
AL2, 2-2
Ground, 2-2
Optional AC Power Supply Input, 2-2
TB102, 2-3
TB301, 4-3
TB301 (Brake / Relay) Current
Specifications, 4-4
TB301 (Brake / Relay) Voltage
Specifications, 4-4
TB4, 4-9
TB7, 4-12
TIL117-M, 4-15
-TRIPLEPSO, 1-5
Troubleshooting, 6-1
Two Axis Laser Firing, 4-19
Typical ESTOP Interface, 2-6

U

Unknown Phase/Hall Sequence, 2-12
User Power Connector Pinouts, 4-10

V

Voltage configurations, 1-5

W

Warnings, 2-1
Warranty Information, C-1

▽ ▽ ▽

