

**OPERATOR'S MANUAL FOR THE
160V, 100QV AND 80QV
SIX AXIS 19" RACK
(RAV)**

**(M160.30-V, M100.25-QV
AND M80.20-QV)**

MAY, 1987

PATENT NO. 4,554,512



**AEROTECH, INC., 101 Zeta Drive, Pittsburgh, PA 15238
(412) 963-7470 TWX 710-795-3125**

NOTICE

AEROTECH'S DESIGNATION OF THE "160V, 100QV AND 80QV" SERVO CONTROLLERS DESCRIBED IN THIS MANUAL HAS BEEN CHANGED TO "M160.30-V, M100.25-QV AND M80.20-QV". WHEN ORDERING OR WHEN REQUESTING TECHNICAL INFORMATION, PLEASE REFER TO THE "M160.30-V, M100.25-QV AND M80.20-QV" SERVO CONTROLLER.

TABLE OF CONTENTS

CHAPTER 1:	INTRODUCTION.....	1-1
CHAPTER 2.....		2-1
SECTION 2-1	GENERAL DESCRIPTION.....	2-1
SECTION 2-2	MODULE IDENTIFICATION.....	2-4
SECTION 2-3	ELECTRICAL SPECIFICATIONS.....	2-5
SECTION 2-4	DESCRIPTION OF COMPONENTS (SERVO MODULES)...	2-9
SECTION 2-5	DESCRIPTION OF COMPONENTS (SUPERVISORY MOD.)	2-22
SECTION 2-6	COMPONENT DESCRIPTION, 19" RACK	2-29
SECTION 2-7	TERMINAL BOARD.....	2-33
CHAPTER 3.....		3-1
SECTION 3-1	INSTALLATION AND START-UP.....	3-1
SECTION 3-2	ADJUSTING INPUT AND TACH POTS FOR	3-14
SECTION 3-3	LIMITING MAXIMUM ALLOWABLE MOTOR CURRENT...	3-16
SECTION 3-4	MINIMIZING RIPPLE CURRENT	3-19
CHAPTER 4.....		4-1
SECTION 4-1	TROUBLESHOOTING (19" RACK).....	4-1
SECTION 4-2	TROUBLESHOOTING (SERVO AMPLIFIER MODULES)...	4-2
SECTION 4-3	TROUBLESHOOTING (SUPERVISORY MODULE).....	4-5
CHAPTER 5.....		5-1
SECTION 5-1	SERVICE AND REPAIR.....	5-1
SECTION 5-2	SHIPMENT.....	5-1
SECTION 5-3	PARTS LIST (19" RACK).....	5-2
SECTION 5-4	PARTS LIST (SERVO MODULES).....	5-3
SECTION 5-5	PARTS LIST (SUPERVISORY MODULE).....	5-4

INDEX

LIST OF ILLUSTRATIONS

2-1:	VELOCITY LOOP CONFIGURATION.....	2-1
2-2:	MODULE IDENTIFICATION LOCATIONS.....	2-4
2-3:	ELECTRICAL SPECIFICATIONS (SERVO AMPLIFIER MODULE).....	2-5
2-4:	ELECTRICAL SPECIFICATIONS OF SUPERVISORY MODULE.....	2-8
2-5:	TOP AND FRONT VIEW OF SERVO AMPLIFIER MODULE.....	2-10
2-6:	GENERAL FUNCTIONAL DIAGRAM OF THE SERVO.....	2-11
2-7:	COMPONENT DESCRIPTION FOR SERVO AMPLIFIER MODULE.....	2-12
2-8:	CHARACTERISTICS OF THE RMS CURRENT LIMIT CIRCUIT.....	2-16
2-9:	CHARACTERISTICS OF THE DYNAMIC CURRENT LIMIT.....	2-17
2-10:	ELECTRICAL OUTLINE OF PRE-AMPLIFIER CIRCUIT WITH.....	2-18
2-11:	SPECIFICATIONS OF PERSONALITY MODULES.....	2-19
2-12:	TOP AND FRONT VIEW OF SUPERVISORY MODULE.....	2-23
2-13:	SIMPLIFIED ELECTRICAL DIAGRAM OF THE SUPERVISORY.....	2-24
2-14:	COMPONENT DESCRIPTION (SUPERVISORY MODULE).....	2-25
2-15:	SCHEMATIC OF 19" RACK.....	2-30
2-16:	(A) FRONT VIEW OF 19" RACK.....	2-31
2-17:	SCHEMATIC OF TERMINAL BOARD.....	2-34
2-18:	BACK VIEW OF 19" RACK.....	2-35
2-19:	TERMINAL BOARD CONNECTIONS TO AXIS 1 (AXIS 2 AND 3.....	2-36
2-20:	CONTROL CONNECTIONS DESCRIPTIONS FOR TERMINAL BOARD.....	2-37
3-1:	LOCATIONS OF HIGH VOLTAGE ON SUPERVISORY AND SERVO.....	3-2
3-2:	BACK VIEW MOUNTING SPECIFICATIONS FOR 19" RACK.....	3-3
3-3:	FRONT VIEW MOUNTING SPECIFICATIONS FOR 19" RACK.....	3-4
3-4:	INPUT POWER CONFIGURATION FOR THE 160V SERIES 19" RACK.....	3-6
3-5:	INPUT POWER CONFIGURATION FOR THE 100QV SERIES 19" RACK.....	3-8
3-6:	INPUT POWER CONFIGURATIONS FOR THE 80QV SERIES 19" RACK.....	3-10
3-7:	LOCATIONS FOR MOTOR POWER CONNECTIONS FOR AXES 1, 2,.....	3-12
3-8:	ADJUSTING INPUT AND TACH POTS FOR POSITION LOOP.....	3-15
3-9:	LIMITING MAXIMUM ALLOWABLE MOTOR CURRENT WITH.....	3-18
3-10:	ADJUSTABLE GAIN POT TO MINIMIZE RIPPLE CURRENT IN.....	3-20

CHAPTER 1: INTRODUCTION

This manual provides information on the installation, set up and operation of the 160V, 100QV and 80QV SERIES Servo Amplifiers used on the RAV 19" rack.

Included in this manual is information on the set-up and adjustments of the 160V, 100QV and 80QV Servo Amplifier Module and Supervisory Module, as well as information on wiring the 19" rack into a system.

One line diagrams are also included on the operational characteristics of each servo amplifier module and supervisory module. More detailed information, such as Theory of Operation, is included in supplemental literature which is readily obtained upon request (see section 5, Service and Repair).

A description of the general operational characteristics of the servo and supervisory modules is given in section 2, General Description. This section includes module identification and electrical specifications.

A detailed description for the installation and set-up of these servo modules is given in section 3, Installation and Start-up.

Information on field troubleshooting and general repair is presented in section 4, Troubleshooting and section 5, Service and Repair, respectively.

CHAPTER 2

SECTION 2-1 GENERAL DESCRIPTION

The 160V, 100QV and 80QV SERIES Servo Amplifier Modules are very high gain transconductance amplifiers intended primarily to drive a permanent magnet (PM) DC motor. Typically, a servo module is used with a motor and a tachometer in a velocity loop configuration (refer to figure 2-1). Here a velocity input command, a voltage between $\pm 10V$, is summed with the tachometer output (negative-feedback-phased) to produce a net voltage input to the servo amplifier module; the module provides an output current to the motor, proportional to the net input. For user convenience, separate input terminals and individual scale (gain) controls are provided for both command and tachometer voltages. Summation takes place within the module itself.

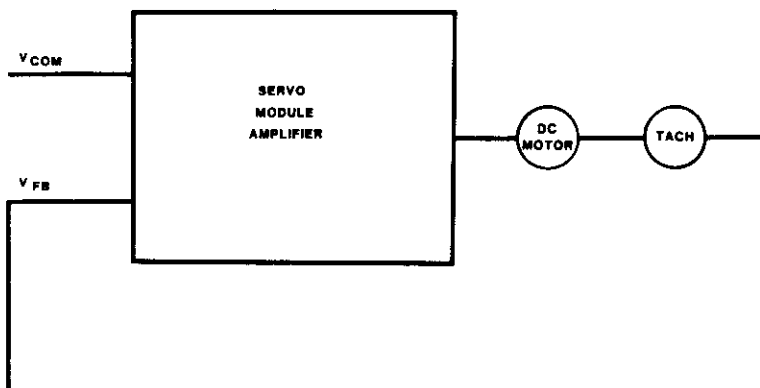

FIGURE 2-1: VELOCITY LOOP CONFIGURATION

CHAPTER 2

The module obtains its high transconductance (ie., voltage in gives current out) through a pre-amplifier/post-amplifier arrangement, wherein the pre-amplifier supplies a voltage gain of 2000 V/V and the post-amplifier supplies a transconductance of 5 amps per volt (A/V). The pre-amplifier is an operational-amplifier based gain block which provides customer adjustable compensation. The post-amplifier is a pulse-width-modulated voltage amplifier contained within a current feedback loop configuration, internal to the module. No customer adjustment of the post-amplifier is required. For the 160V, 100QV and 80QV SERIES Amplifier Modules, the overall transconductance is 10,000 A/V.

To further explain the arrangement shown in figure 2-1, any difference in magnitude between the scaled input command and the scaled negative-feedback tachometer output results in a proportional current into the motor. This current accelerates or decelerates the motor until the motor speed matches the (scaled) input command, less a small amount due to load friction. Since the module has a current output proportional to speed error, rather than a voltage output, developed motor torque, and hence acceleration, are likewise proportional to speed error, independent of back emf, resistance and inductance within the motor. This renders a higher degree of accuracy to the user.

To protect the motor, maximum current to the motor is controlled through self contained, isolated current feedback clamp circuits. A current trip (shutdown) circuit is activated if the motor current instantaneously exceeds a safe operating level. These current feedback clamp circuits are as follows:

1. The Current Limit Circuit clamps the command signal, the output of the pre-amplifier, at a certain level, either positive or negative. This clamping level is adjustable through the Current Limit Pot, the adjustment range varying for each of the three servo modules.

CHAPTER 2

2. The Dynamic Current Limit Circuit monitors the Tach Feedback Signal, and controls the current limit ranges dynamically, that is, as a function of motor speed.
3. The RMS Current Limit Circuit monitors the current feedback signal. If the output current should exceed the continuous current rating of the servo module for a given length of time, the RMS Current Limit Circuit will clamp the output current to a level of 50% of the continuous current rating of the amplifier and will energize the RMS Limit LED.

The 160V, 100QV and 80QV SERIES Servo Amplifier Modules require a supervisory module for operation. The supervisory module provides the following functions:

1. A circuit that senses high voltage conditions at the bus supply connections to the servo module, activating the Shunt Regulator if the voltage becomes excessively high.
2. A circuit to provide a shutdown to the servo module if the Shunt Regulator becomes overloaded (the shunt fuse opens). A + or - 12 VDC supply to provide power to the control stages of the servo modules.
3. A means of distributing input/output logic and analog control signals to the servo module(s) from an external controller.

SECTION 2-2 MODULE IDENTIFICATION

Figure 2-2 shows the label locations for identification of the three types of servo amplifier modules and supervisory module. The labels are located on the top of each of the modules.

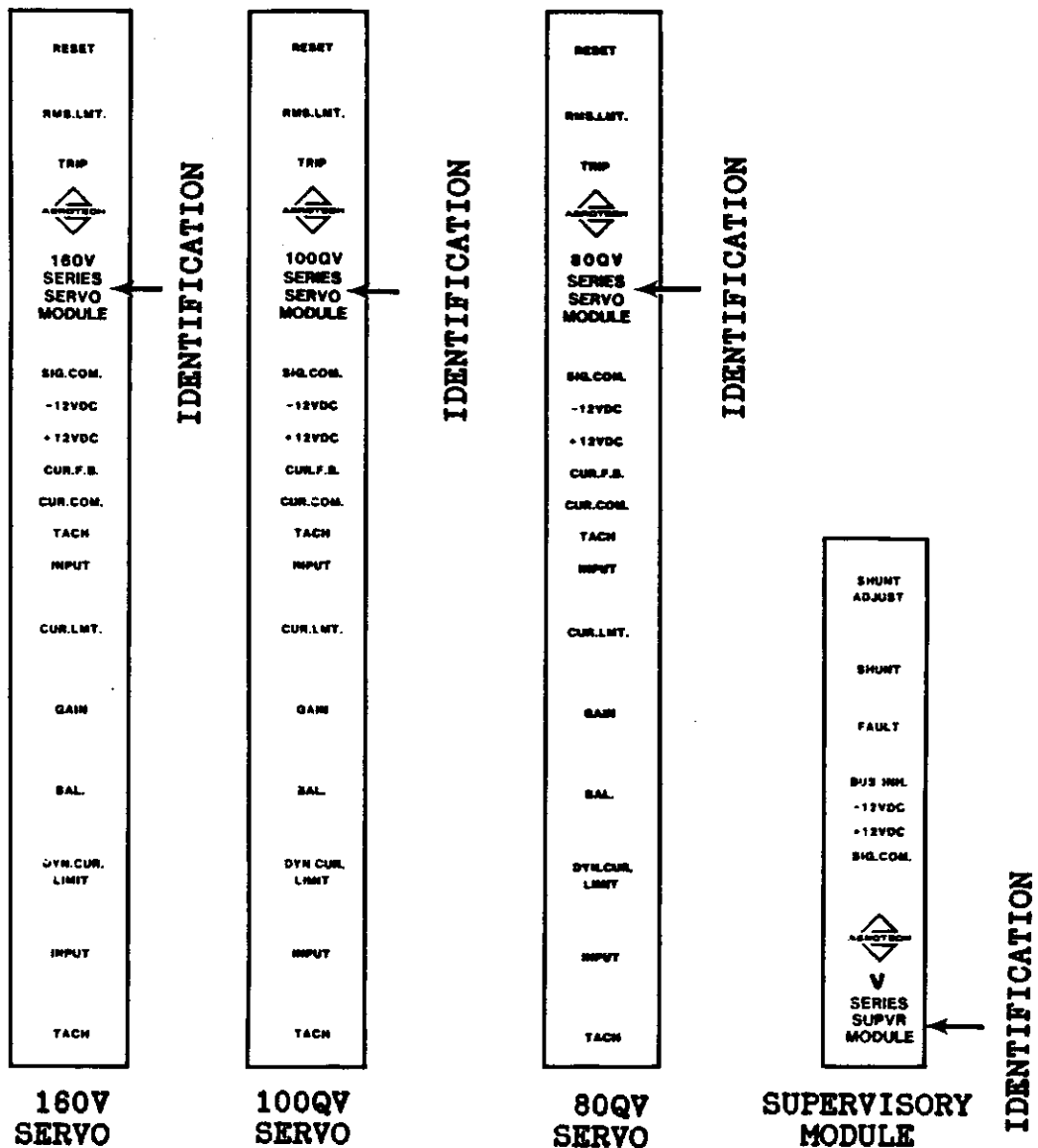

FIGURE 2-2: MODULE IDENTIFICATION LOCATIONS

SECTION 2-3 ELECTRICAL SPECIFICATIONS

Electrical specifications for the amplifiers and supervisory module are shown in figure 2-3 and 2-4. These specifications are broken up into two headings, POWER and CONTROL.

ELECTRICAL SPECIFICATIONS FOR SERVO AMPLIFIER MODULE**POWER**

	<u>160V</u>	<u>100QV</u>	<u>80QV</u>
Power output current (max., amps)	30	25	20
Continuous output cur. (max., amps)	15	12	10
DC bus input voltages (volts)			
Maximum	195	125	100
Minimum (for conduction)	10	10	5
Nominal	165	100	80
Output power* (max., watts)			
Peak	4350	2250	1400
Continuous	2200	1150	700
Load inductance* (min., mH)	4.5	2	2
Switching frequency (nominal, KHz)	5	18	20
Operating temperature (C degrees)	-----	0° to 50°	-----
Storage temperature (C degrees)	-----	-30° to 85°	-----

FIGURE 2-3: ELECTRICAL SPECIFICATIONS (SERVO AMPLIFIER MODULE)

FIGURE 2-3: CONTINUED

CONTROL

CURRENT LOOP (POWER AMPLIFIER)

	<u>160V</u>	<u>100QV</u>	<u>80QV</u>
Current feedback (current monitor) gain (amp/volt)	5	5	5
Current command gain (amp/volt)	5	5	5
Current limit adjustment range** (amps)	0 to 30	0 to 25	0 to 20
Dynamic current limit foldback range** (amps)	0 to 30	0 to 25	0 to 20
RMS current limit initiation level** (amps)	15	12.5	10
Short circuit current trip level (manual reset) (amps)	43	37	25
Power amplifier bandwidth (nominal, KHz)	-----	1.0	-----

RATE LOOP (PRE-AMPLIFIER)

Voltage gain (open loop, dB)	-----	100	-----
Tach feedback signal*** (nom., volts)	-----	10	-----
Speed command signal*** (nom., volts)	-----	10	-----

CHAPTER 2

FIGURE 2-3: CONTINUED

	<u>160V</u>	<u>100QV</u>	<u>80QV</u>
Tach feedback signal input impedance (min., Kohms)	-----	9.5	-----
Speed command signal input impedance (min., Kohms)	-----	6.5	-----
Speed command input signal, offset null adjustment (max., + and - mV)	-----	15	-----
Pre-amplifier output drift (nominal, mV/C degrees)	-----	10	-----
Pre-amplifier bandwidth**** (nominal, Hz)	-----	100	-----

* Data relative to nominal (no load) DC bus input voltage of 160VDC for the 160V Amplifier, 100VDC for the 100QV Amplifier and 80VDC for the 80QV amplifier.

** Current levels field adjustable through "personality" modules.

*** Tach and speed signal levels can be accepted up to +60 volts with different "personality" modules.

**** Measurements taken with Aerotech Model 1410 motors.

ELECTRICAL SPECIFICATIONS FOR SUPERVISORY MODULE

POWER

	160V	100QV	80QV
Low voltage bus shut-off	-----	none	-----
High voltage bus* shut-off (shunt regu- lator adjustment range)	55-195 VDC	55-125 VDC	55-100VDC
Shunt regulator regenerative energy capability (max)	-----	20 amps, * 2 secs. (max) @ 20 second duty cycle	-----

CONTROL

+ and - 12 VAC power supply shutdown and inhibit	-----	Activated if the input line voltage at base plate terminals 1TB2, 1 and 2, or 2TB2, 1 and 2, drops below 95 VAC	-----
--	-------	---	-------

- * Adjusted concurrently with DC shunt adjust pot. If shunt regulator is overloaded (shunt fuse opens) high DC bus voltage shutdown is activated. 160V, 100QV and 80QV servo modules use the same supervisory module. Full CW setting allows 195 VDC shunt level. This maximum setting is applicable to only the 160V servo module.

FIGURE 2-4: ELECTRICAL SPECIFICATIONS OF SUPERVISORY MODULE

SECTION 2-4 DESCRIPTION OF COMPONENTS (SERVO MODULES)

Locations of fuses, potentiometers, test points and other components for the three types of servo modules that are of concern to the user, are identified in figure 2-5. Figure 2-6 illustrates a one-line diagram of the circuitry contained in the servo module. The locations of components illustrated in figure 2-5 can be represented by their basic functions outlined in figure 2-6.

General descriptions of the components illustrated in figures 2-5 and 2-6 are provided in figures 2-7, 2-8, 2-9 and 2-10.

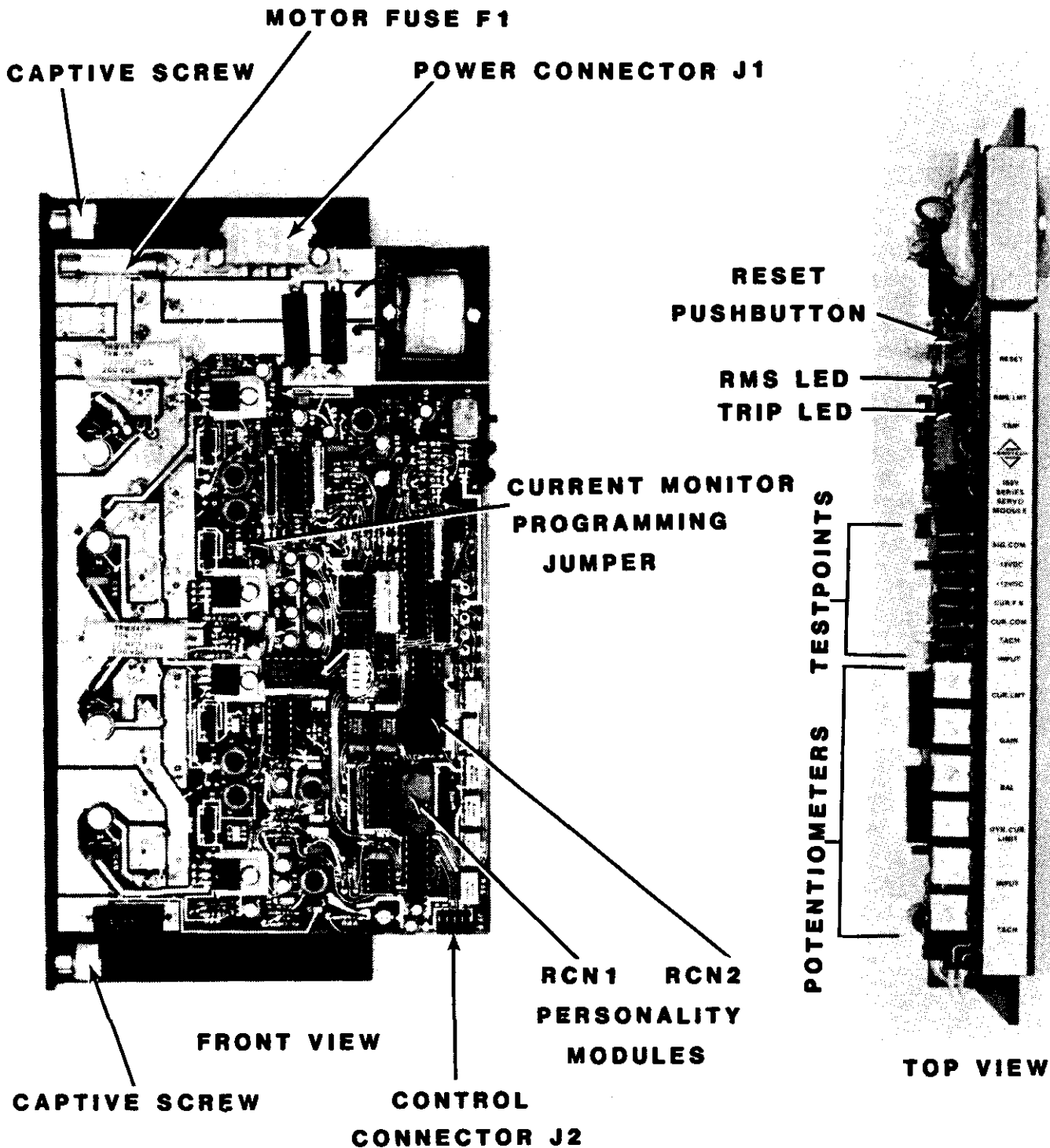

FIGURE 2-5: TOP AND FRONT VIEW OF SERVO AMPLIFIER MODULE

See Figure 2-15:

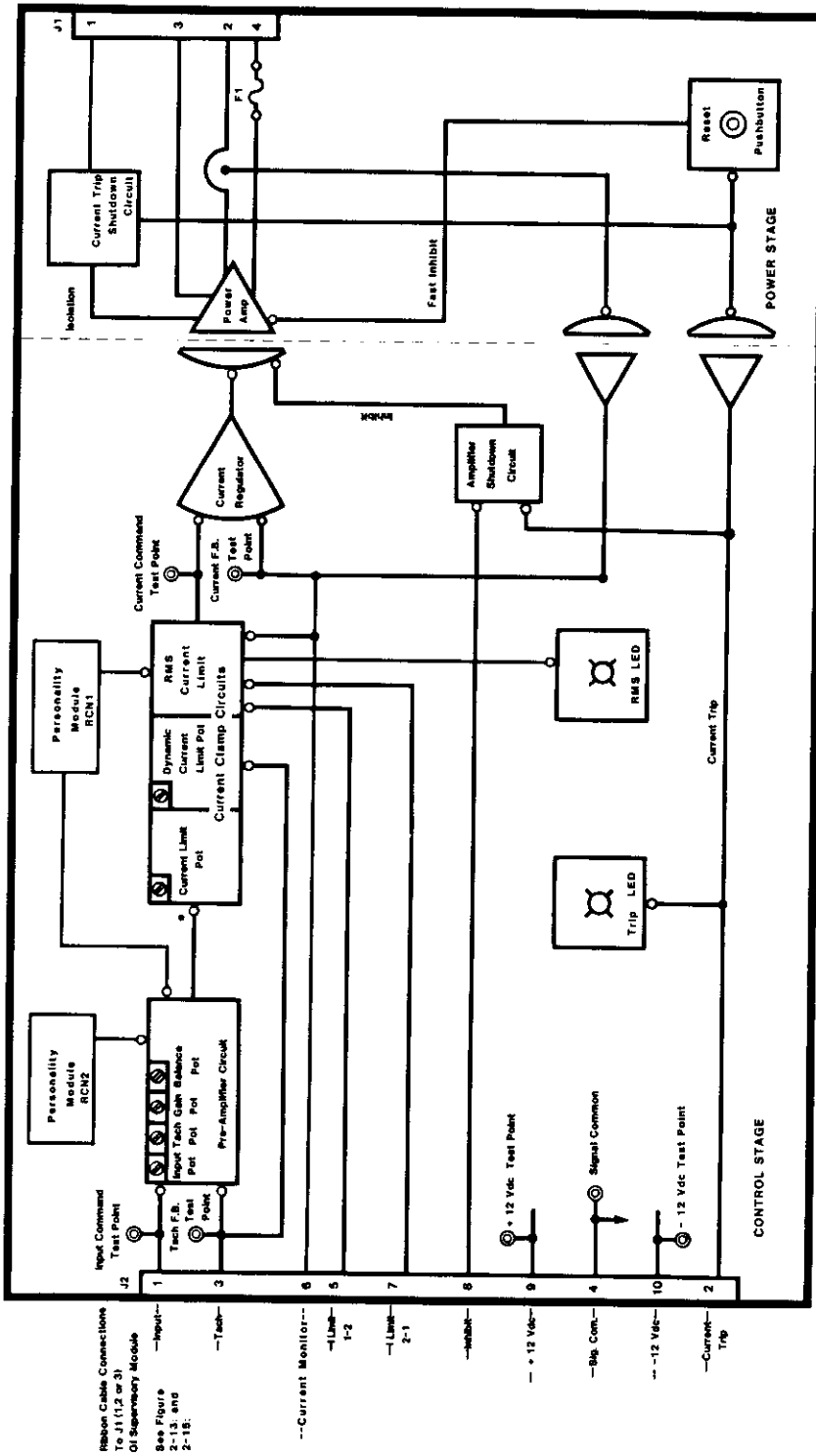

FIGURE 2-6: GENERAL FUNCTIONAL DIAGRAM OF THE SERVO AMPLIFIER MODULE

CHAPTER 2

COMPONENT DESCRIPTION

(Items shown in figures 2-5 and 2-6)

RESET BUTTON	Provides a means of manually resetting a short circuit current trip condition. A successful reset is verified by observing the trip LED change from an energized to de-energized state.
TRIP LED	Trip LED indicator serves as an indication of a short circuit current trip. Current trip levels vary from 42 to 25 amps, depending on the type of servo module. A current trip condition is a latched function requiring a manual pushbutton reset. A shutdown of the servo amplifier with external fault indication is also included.
RMS LIMIT LED	This LED indicates that the motor is drawing excessive current (see figure 2-8). As shown in figure 2-8, the RMS current limit circuitry will automatically limit the motor current to a safe value, if the product of motor current multiplied by the time duration exceeds a given value. Resetting of this limit occurs automatically, if the current command signal (internal to the module) is allowed to fall below the clamp level of the circuit.
SIGNAL COMMON	Signal common for control stage circuitry and testpoints mentioned below.
-12VDC SUPPLY TESTPOINT	Negative power supply testpoint for the control stage.

FIGURE 2-7: COMPONENT DESCRIPTION FOR SERVO AMPLIFIER MODULE

FIGURE 2-7: CONTINUED

+12VDC SUPPLY TESTPOINT	Positive power supply testpoint for the control stage.
CURRENT FEEDBACK TESTPOINT	Provides a means of monitoring the current feedback signal sent back from the power stage. The gain of this signal is 5 amp/volt.
CURRENT COMMAND TESTPOINT	Provides a means of monitoring the current command signal from the pre-amplifier. The gain of this signal is 5 amp/volt.
TACH FEEDBACK TESTPOINT	Provides a means of monitoring the motor's tach feedback signal. This signal is fed to the input of the tach feedback pot.
INPUT (SPEED) COMMAND TESTPOINT	Provides a means of monitoring the speed command signal. This signal is fed to the input command pot.
CURRENT LIMIT POT	This pot provides a means of adjusting the clamp levels of the current command signal produced by the output of the pre-amplifier. The plus as well as the minus current clamp levels are adjusted concurrently with this potentiometer. Turning this pot CCW increases the clamp levels.
GAIN POT	This pot provides the means of adjusting the AC gain of the pre-amplifier. Turning this pot CCW increases gain.
BALANCE POT	The balance pot provides the means of cancelling small DC offsets that may be present on the input (speed) command signal (and the pre-amplifier circuit as well) when the rate (or speed) loop is closed on the pre-amplifier.

FIGURE 2-7: CONTINUED

DYNAMIC CURRENT LIMIT POT	The dynamic current limit pot provides the means of adjusting the current clamp levels of the current command signal dynamically, as a function of motor speed. Motor speed is determined by the magnitude of the voltage on the incoming tach feedback signal. The magnitude of the clamping levels placed on the current command signal is thus dictated by both the current limit pot and dynamic current limit pot. Turning the dynamic current limit pot CCW increases the clamp levels (see figure 2-9).
INPUT COMMAND POT	This pot provides the means of adjusting the DC gain of the input command signal seen on the input command testpoint, at the input of the preamplifier. Turning this pot CW increases gain.
TACH FEEDBACK POT	The function of this pot is to provide a means of adjusting the DC gain of the tach feedback signal seen on the tach feedback testpoint, at the input of the pre-amplifier. Turning this pot CW increases gain.
SUPERVISORY MODULE CONTROL CONNECTION (J2)	Control connections from the supervisory module are terminated at this connector through a 10 pin ribbon cable.
MOTOR LOAD FUSE (F1)	This fuse provides motor overload protection and is sized in the factory to the maximum continuous output current of the amplifier. If motors are used whose continuous current ratings are lower than that of the amplifier driving them, fuse F1 must be resized accordingly.

FIGURE 2-7: CONTINUED

DC BUS INPUT AND MOTOR OUTPUT POWER CONNECTOR (J1)	Connections to the DC bus power supply and motor terminal block (1TB4) of the three axis base plate are made at this connector. The mate to this connector is a four circuit quick-connect plug found on the base plate.
PERSONALITY MODULE (RCN1)	This plug-in module allows the user to easily change the compensation for the following functions: <ol style="list-style-type: none"> 1. Input command and tach feedback scale factor (ie., using tachometers with other standard scales such as 6V/1000RPM, 20V/1000RPM, etc. - see figure 2-10) 2. Foldback and slope characteristics for the dynamic current limit circuit (see figure 2-9). 3. Initiation level for the RMS current limit circuit (see figure 2-8). 4. Maximum allowable adjustment level for the current limit pot.
PERSONALITY MODULE (RCN2)	This plug-in module allows the user to easily change the pre-amplifier compensation (see figure 2-10).
CURRENT MONITOR PROGRAMMING JUMPER	Allows the user to select a uni-directional or bi-directional current monitor output signal.

CHAPTER 2

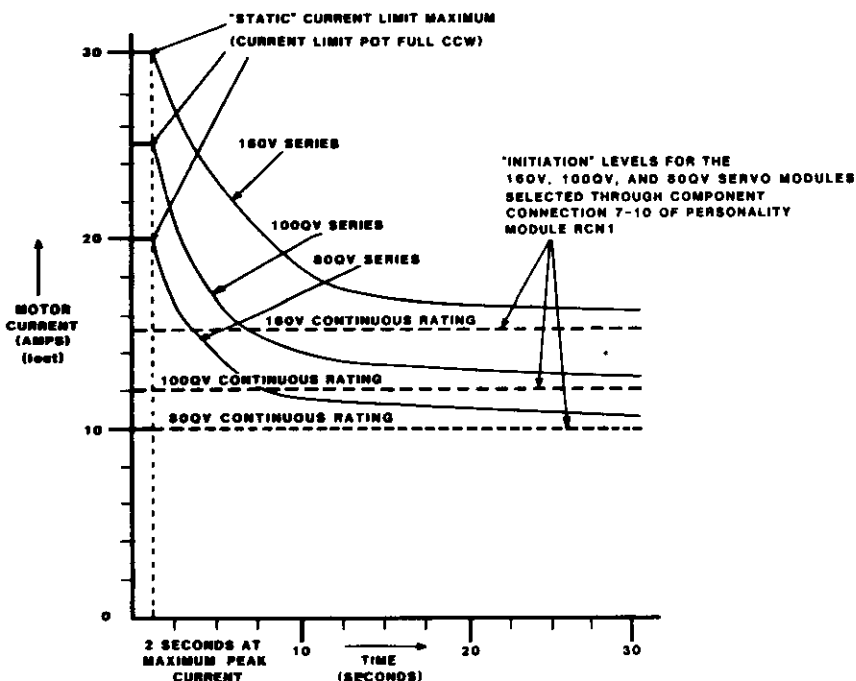

FIGURE 2-8: CHARACTERISTICS OF THE RMS CURRENT LIMIT CIRCUIT

The graph above shows the level of motor current that can be sustained for a given time interval. This graph shows separate curves for the 160V, 100QV and 80QV since the peak and the continuous current rating for each amplifier is different.

The dashed line showing the level of the continuous current rating for each amplifier is selected as the standard level for the "initiation" point of this circuit. In other words, the standard level, where the circuit begins to sense an overload condition, is 15 amps for the 160V, 12.5 amps for the 100QV and 10 amps for the 80QV. These initiation (or sense) levels can be lowered to better match a given motor if desired, by changing a component value in the "personality" module RCN1. (Also see figure 2-11.)

CHAPTER 2

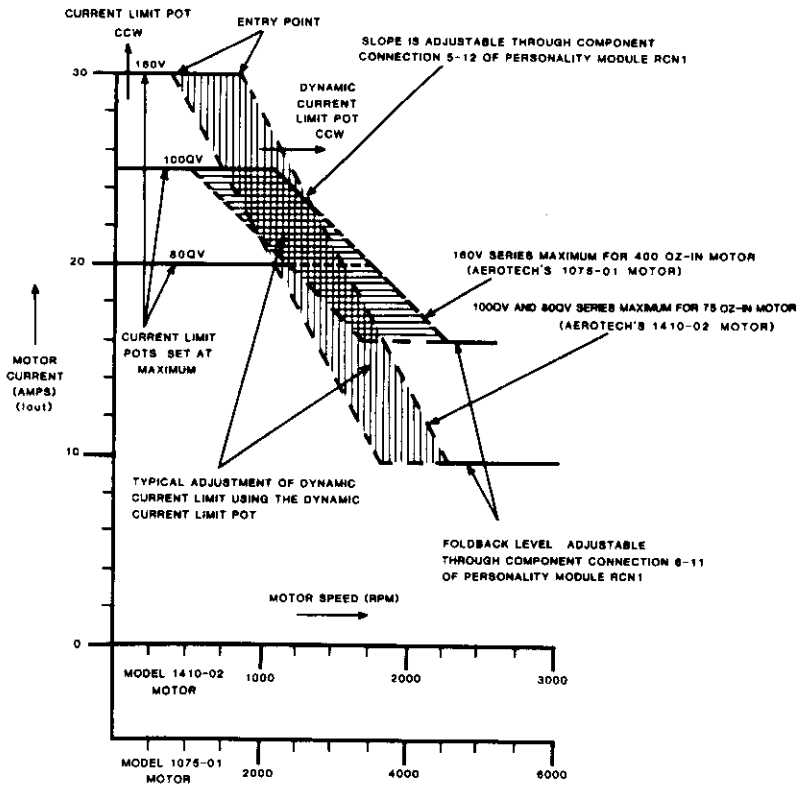

FIGURE 2-9: CHARACTERISTICS OF THE DYNAMIC CURRENT LIMIT CIRCUIT

The graph above shows the effect of the dynamic current limit circuit on the allowable current to the motor at different speeds. Curves for 160V, 100QV and 80QV amplifier modules are shown, relative to two standard Aerotech motors.

Note that the dynamic current limit pot serves only as an adjustment for the "entry" point in which dynamic current limiting is to occur. The slope and foldback curves are not effected.

In many cases, most motor commutation curves can be adapted to the given amplifier module by only adjusting the current limit and dynamic current limit pots. If desired, differing slopes and foldback levels can be obtained by changing component values in "personality" module RCN1 (also see figure 2-11).

CHAPTER 2

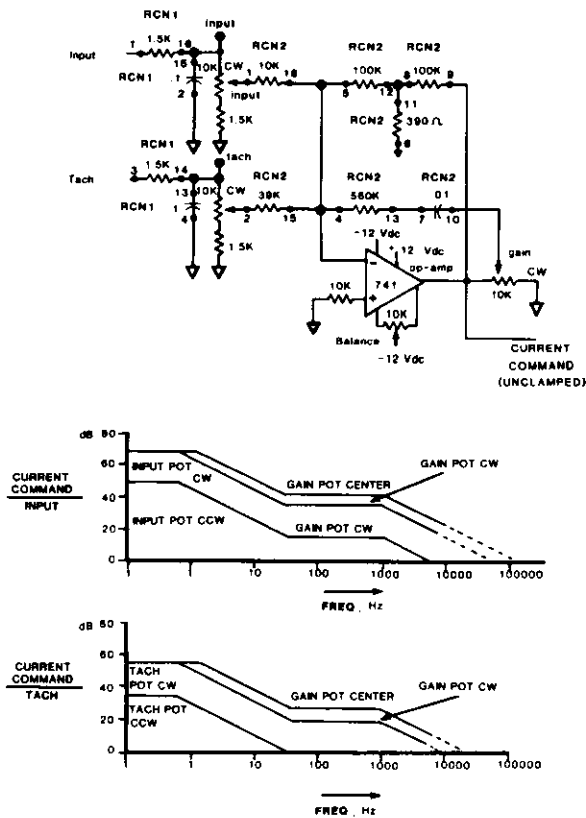

FIGURE 2-10: ELECTRICAL OUTLINE OF PRE-AMPLIFIER CIRCUIT WITH OPEN LOOP GAIN CHARACTERISTICS

The circuit and graphs above show the configuration and gain characteristics of the pre-amplifier circuit. Note that most of the passive components making up the circuit are incorporated into the two personality modules RCN1 and RCN2. RCN2 is dedicated mainly to pre-amplifier compensation. RCN1, however, has two functions. First, to select the initiation, slope and foldback levels of the RMS current limit and dynamic current limit circuits (see figures 2-8 and 2-9). Secondly, to select the "front end" scale factors for the input command and tach feedback connections (also see figure 2-11).

**FIGURE 2-11: SPECIFICATIONS OF PERSONALITY MODULES
RCN1 AND RCN2**

Three standard configurations are available for both RCN1 and RCN2. These configurations, used in the 160V, 100QV or 80QV servo module, have been selected to optimize six standard Aerotech motors.

The six motors are listed below. General specifications for each motor are also listed so that a cross between different motor manufacturers can be made.

<u>AEROTECH MOTOR</u>	<u>RATED CONTINUOUS</u>	<u>KT OZ. IN/AMP</u>	<u>KB VOLTS/KRPM</u>	<u>TACH OUTPUT VOLTS/KRPM</u>
1960-02-01	960	80	59	3
1580-02-01	580	65	48.1	3
1410-02-01	410	70	52.2	3
1210-01-01	210	35	25.9	3
1135-01-01	135	25	18.15	3
1075-01-01	75	14	10.37	3

The three standard sets of personality modules RCN1 and RCN2, that are selected as matches for the six motors listed above, are as follows:

1960-02-01 1580-02-01 1410-02-01	RCN1-1 and RCN2-1
1210-01-01 1135-01-01	RCN1-2 and RNC2-2
1075-01-01	RCN1-3 and RCN2-3

FIGURE 2-11: CONTINUED

It should be noted that the 160V is shipped with personality modules RCN1-1 and RCN2-1, the 100QV is shipped with personality modules RCN1-2 and RCN2-2 and the 80QV is shipped with personality modules RCN1-3 and RCN2-3. Even though these modules may not have been optimized for other types of motors the user has selected, with proper servo tuning (via adjustment pots) these modules can be used for practically any motor.

If desired, the user can fabricate his own personality modules by specifying RCN1-4 and RCN2-4 (see section 5-4). The header and cover would be supplied without the components installed. The user would only need an assortment of 1/4 watt carbon-film resistors and small signal ceramic capacitors to make his own modules.

The standard values incorporated in RCN2-1 are as follows: (refer to figures 2-9 and 2-10).

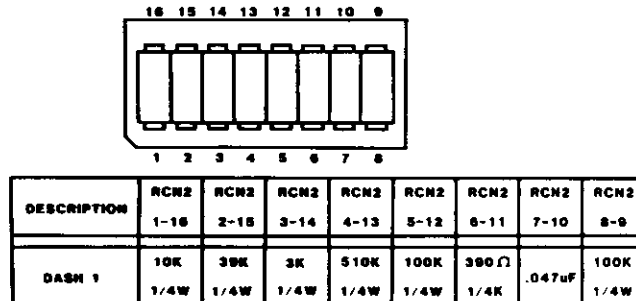

Dynamic Current Limit Entry with
Dynamic Current Limit Pot set full CW
(Figure 2-9)

$$\text{Entry point (Krpm)} = [.6 \cdot \text{RCN1}(5-12)] / [\text{Tach constant} \cdot (1.5 + 10 / \text{RCN2}(3-14))]$$

Where:

RCN1(5-12) and RCN2(3-14) is in Kohms
Tach constant is volt/Krpm

FIGURE 2-11: CONTINUED

The standard values incorporated in RCN1-1 are as follows:

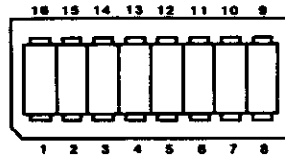

DESCRIPTION	RCN1 1-18	RCN1 2-18	RCN1 3-14	RCN1 4-13	RCN1 5-12	RCN1 6-11	RCN1 7-10	RCN1 8-9
DASH 1	1.5K 1/4W	.1 μF	1.5K 1/4W	.1 μF	30K 1/4W	62K 1/4W	4.3M 1/4W	4.7K 1/4W

Pre-amplifier input
scale factor (fig. 2-10)

Dynamic current limit slope (fig. 2-9)

Slope (amp/Krpm) =
Tach constant • 100/RCN(5-12)
Where:
"Tach Constant" is in volt/Krpm
"RCN1(5-12)" is in Kohms

Dynamic current limit foldback (fig. 2-9)

I(foldback) in amps = 600/RCN1(6-11)
Where:
"RCN1(6-11)" is in Kohms

RMS current limit initiation (fig.2-8)

I (initiation) in amps = 66/RCN1(7-10)
Where:
"RCN1(7-10)" is in Mohms

Static current limit (fig.2-8)

I(max) in amps =
300/(RCN1(8-9) + 5)
Where:
"RCN1(8-9) is in Kohms

SECTION 2-5 DESCRIPTION OF COMPONENTS (SUPERVISORY MODULE)

Location of fuses, potentiometers, test points, and other components for the two types of supervisory modules are identified in figure 2-12. Figure 2-13 illustrates a one-line diagram of the circuitry contained in the supervisory module. The locations of components illustrated in figure 2-12 can be represented by their basic functions outlined in figure 2-13.

General descriptions for the components illustrated in figures 2-12 and figure 2-13 are provided in figure 2-14.

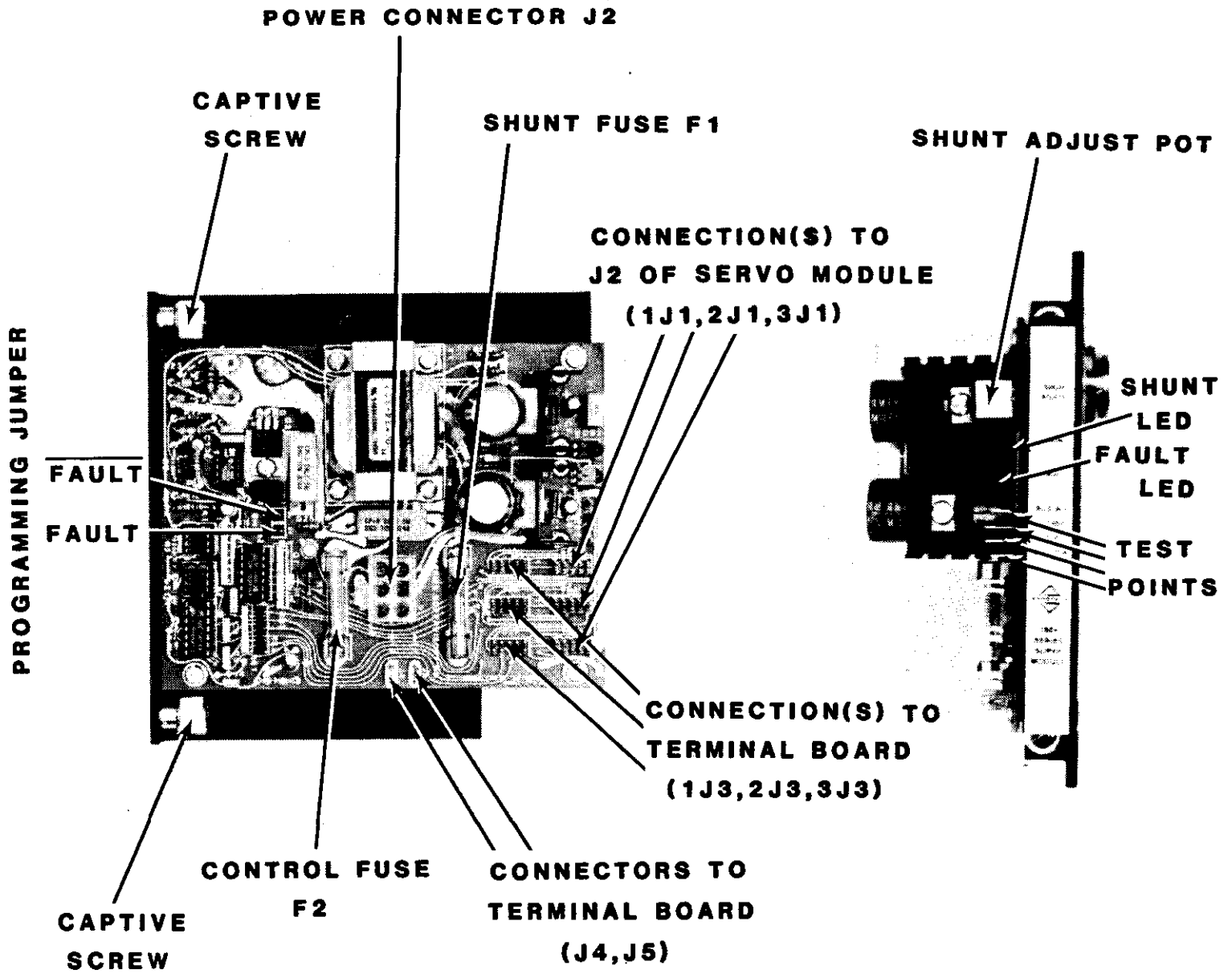

FIGURE 2-12: TOP AND FRONT VIEW OF SUPERVISORY MODULE

FIGURE 2-14: COMPONENT DESCRIPTION (SUPERVISORY MODULE)
 (THE FOLLOWING ITEMS ARE SHOWN IN FIGURE 2-12 AND 2-13)

SHUNT ADJUST POT	Provides a means of adjusting the activation level of the Shunt Regulator Circuit. As shown in figure 2-3, Electrical Specifications recommended adjustment range is 55 (full CCW) to 195VDC (full CW) for the 160V SERIES, 55 (full CCW) to 125 VDC for the 100QV SERIES, and 55 (full CCW) to 100 VDC for the 80QV SERIES.
SHUNT LED	Gives indication that shunt regulator circuit is activated.
FAULT LED	Gives indication of a high bus voltage condition (shunt failure). Also gives indication of a low +12 VDC or a low -12VDC power supply condition.
BUS INHIBIT TESTPOINT	When this testpoint registers zero voltage with respect to signal common, a fault shut-off condition exists on the supervisory module.
-12VDC TESTPOINT	Negative power supply testpoint for the control stage.
+12VDC TESTPOINT	Positive power supply testpoint for the control stage.
SIGNAL COMMON TESTPOINT	Signal common for the three test points (Bus Inhibit, -12 VDC, and +12VDC).
CONNECTOR J2	Connector which accommodates the large resistor leading to the Shunt Regulator circuit, the 115 VAC supply needed to generate the +12VDC, and the DC bus voltage connections necessary for the detection of high voltage.
FUSE F1	Provides overload protection for the Shunt Regulator circuit and resistor.

FIGURE 2-14: CONTINUED

FUSE F2	Provides overload protection for the transformer which supplies power to the ± 12 VDC regulators.
CONNECTORS 1J1, 2J1, AND 3J1	Connects supervisory module, through ribbon cables, to connector J2 of each servo module. Each J1 connector is able to serve one servo module. The supervisory module is therefore capable of servicing up to three servo modules. The first digit, ie., 1, 2 or 3, specifies the axis intended.
CONNECTORS 1J3, 2J3 AND 3J3	Connects supervisory module, through ribbon cables, to J2, J3 and J4 of the terminal board on the base plate. Each J3 connector is responsible for one axis and, as in the case of the J1 connectors, the first digit, ie., 1, 2 or 3, specifies the axis intended.
CONNECTORS J4 AND J5	Provides the ± 12 VDC connection to TB5 and TB6 of the terminal board on the base plate. <u>NOTE:</u> Maximum current draw on either ± 12 VDC connection is 3 mA.
FAULT AND FAULT PROGRAMMING JUMPER	Allows the user to select a "normally low" or "normally high" activation of the open collector fault output driver transistor.

FIGURE 2-14: CONTINUED

(THE FOLLOWING ITEMS ARE SHOWN IN FIGURE 2-13 ONLY)

POWER

- | | |
|------------------------|--|
| SHUNT REGULATOR
POT | Provides a means of adjusting the activation level of the Shunt Regulator Circuit (minimum shunt is full CCW, maximum shunt is full CW). |
| HIGH DC BUS DETECT | Alarms a high voltage condition on the DC bus, when the DC shunt fuse is opened. |

CONTROL

- | | |
|--|---|
| CONTROL
TRANSFORMER | Supplies power to ± 12 VDC regulators. The transformer is energized by a 115VAC supply, which connects through connector J2. |
| CONTROL VOLTAGE
RECTIFIER AND
FILTER CIRCUIT | Supplies ± 30 VDC (unregulated) to the ± 12 VDC regulators. It is energized by the control transformer. |
| ± 12 VDC AND -12 VDC
REGULATOR CIRCUITS | Supply ± 12 voltage (regulated) to the control stage of the servo module(s) and also to the external ± 12 VDC supplies on the terminal board. Both regulator circuits are energized by the control voltage and rectifier circuit. |
| ± 12 VDC LOW LEVEL
DETECT CIRCUIT | Detects low level voltages of control power supply, and signals user of condition by energizing Fault LED of the fault time-out circuit. |

FIGURE 2-14: CONTINUED

FAULT TIME-OUT
CIRCUIT

Signals servo modules and fault driver output circuit of a fault condition at either the high DC bus detect circuit or the $\pm 12\text{VDC}$ low level detect circuit. This circuit activates an immediate shut down signal to all servo modules which remains in effect for at least 2 seconds. After that time period, if condition(s) no longer exist, normal operation resumes automatically.

FAULT DRIVER
OUTPUT CIRCUIT

Signals from the current trip connections (pin 2) of 1J1, 2J1 or 3J1, or from the fault time-out circuit, are fed to this circuit, causing an open collector transistor to saturate (turn on) or cut-off (turn off), depending on the position of the FAULT - /FAULT (typical) programming jumper. The user can select in which state the open collector transistor is to announce a fault connection. Placing the jumper in the /FAULT position turns "on" the transistor during a fault condition. Placing the jumper in the FAULT position turns "off" the transistor during a fault condition. The open collector transistor can sink up to 30 mA and block 35 volts DC.

NAND LOGIC

The outputs of these circuits are fed to the inhibit inputs of the servo module(s). These circuits are activated by either pulling the shut down (SD) input from the terminal board, or the output of the fault time-out circuit, to signal common.

SECTION 2-6 COMPONENT DESCRIPTION, 19" RACK

Included in this section are diagrams and a schematic for the 19" rack.

The 19" rack provides the site for internal connections to be made between the supervisory modules, servo modules, DC bus power supplies and the terminal boards. It also provides for the external connections of AC input power and control connections to the supervisory modules and servo modules.

The 19" rack chassis contains two separate input power supplies and control input terminal boards. Our power supply and terminal board are depicted for 1 set of servo modules (up to three) and a supervisory module. For example, the power supply input connections for axes 1, 2 and 3 are fed to 1TB1, 1TB2 and 1TB3. Motor connections for these axes are terminated on the terminal board designated for axis 1, axis 2 and axis 3. Power supply termination for axis 4, 5 and 6 are fed to 2TB1, 2TB2 and 2TB3. Motor connections for these axes are terminated on 2TB4, with the control connections terminated on the terminal board designated for axis 4, axis 5 and axis 6. As can be seen, these two sets of power supplies and terminal boards are identical in format. The difference is only the set of axes to which they supply power and control. Functional descriptions of the 19" rack with its control input terminal boards are given in the following paragraphs.

Figure 2-15 illustrates the schematic of the internal wiring on the 19" rack. Figure 2-16 shows a front view of the 19" rack. Note, on figure 2-16, the 19" rack shown contains three 160V servo modules (axes 1, 2 and 3) with a supervisory module on the left side, and three 4020 servo modules (not explained in this manual) on the right side of the unit. Remember, this arrangement is applicable since each side of the 19" rack controls its own power supply and terminal board.

SERVO MODULES (4020) *
 AXIS 6 AXIS 5 AXIS 4

SERVO MODULES (160V, 100QV OR 80QV)
 AXIS 3 AXIS 2 AXIS 1

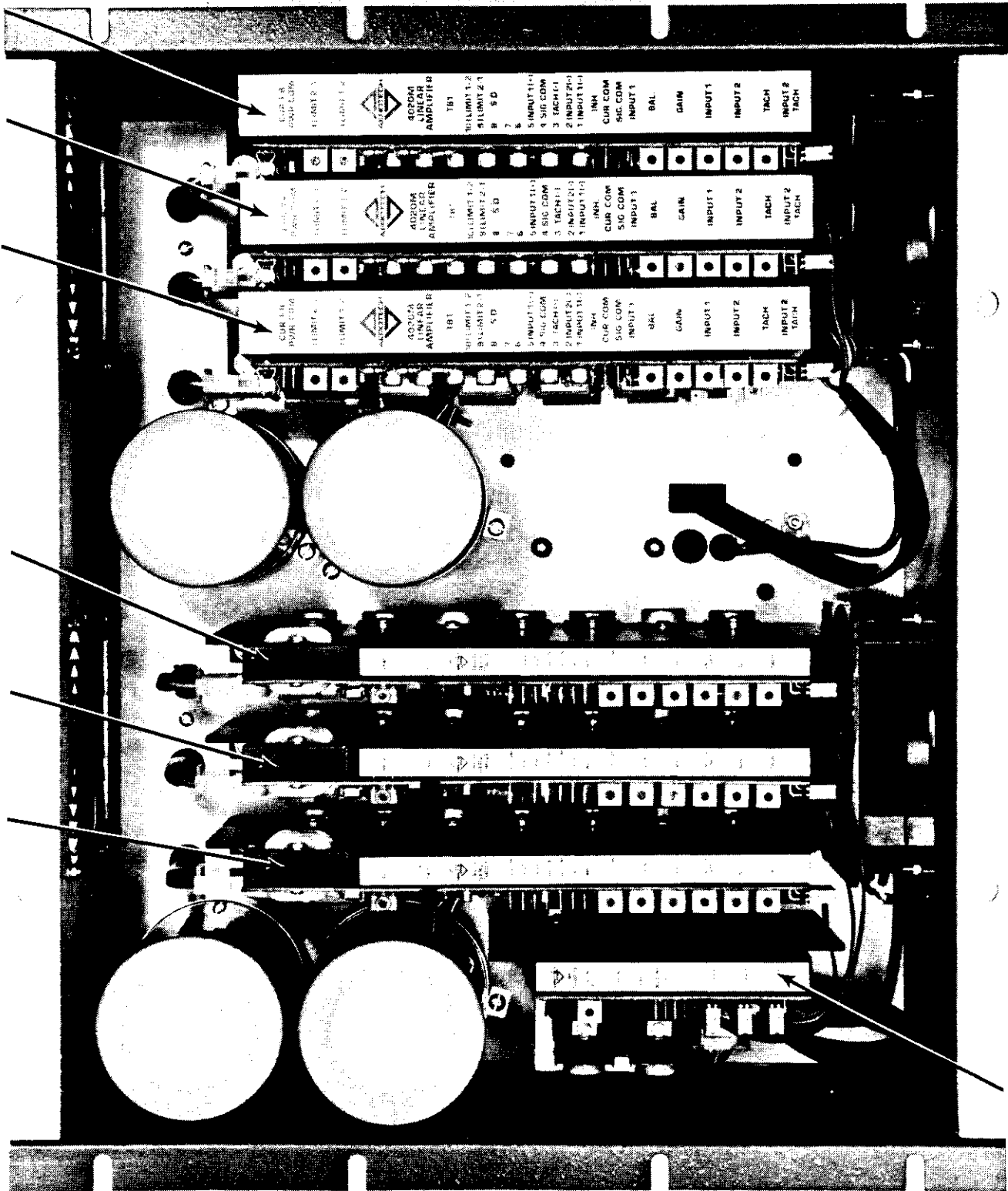

* REFER TO THE 4020 SERVO
 MODULE MANUAL FOR INFORMATION
 ON THESE MODULES

SUPERVISORY MODULES
 FOR AXIS 1, 2 AND 3

FIGURE 2-16: (A) FRONT VIEW OF 19" RACK

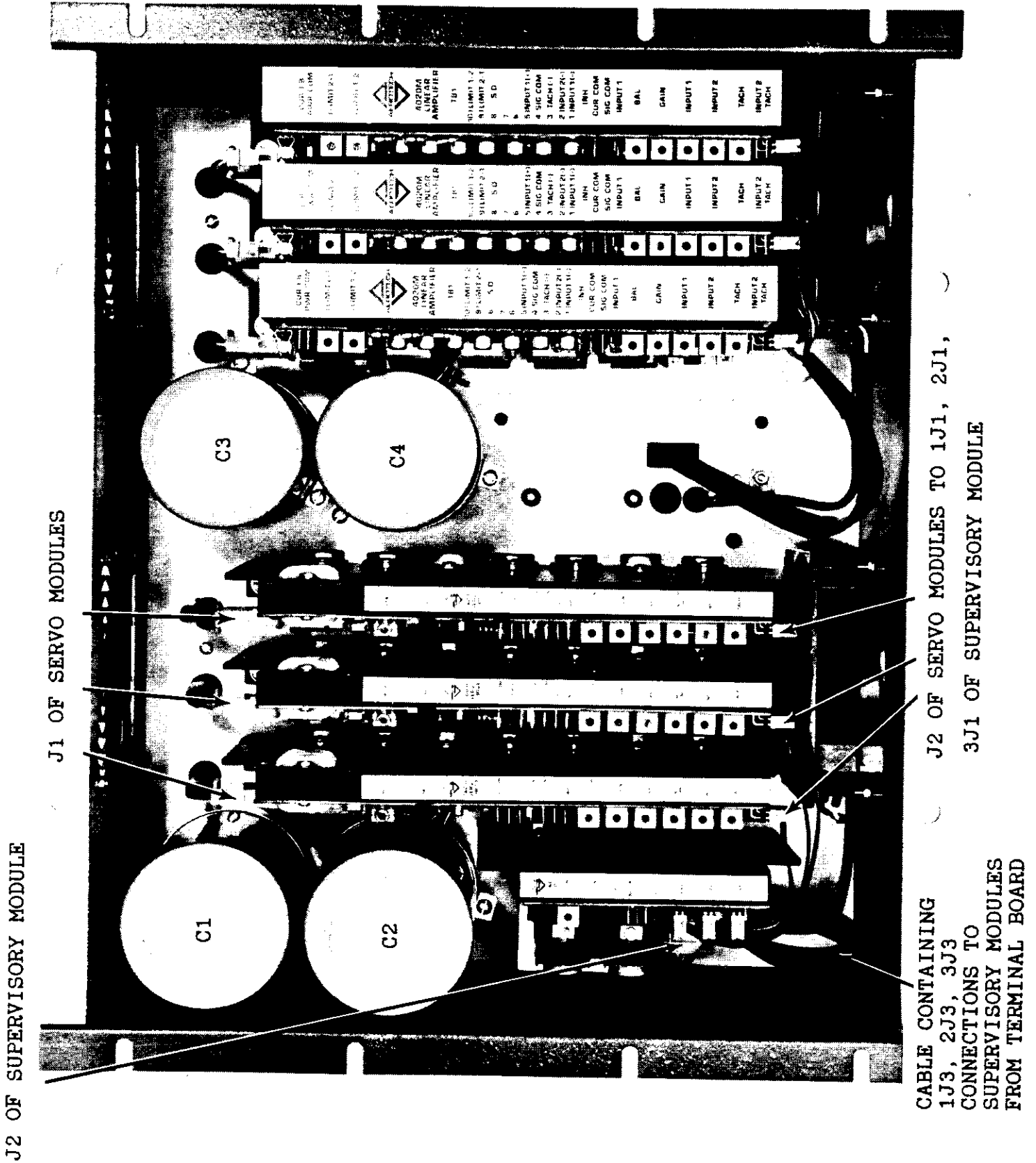

FIGURE 2-16: (B) CONTINUED

SECTION 2-7 TERMINAL BOARD

The 160V, 100QV and 80QV 19" rack utilizes the terminal boards as mechanisms for interfacing control connections from an external controller to the supervisory modules. Figure 2-17 shows the schematic of a given terminal board. Locations of connections to the terminal board from an external controller are shown in figure 2-18.

Referring to figure 2-17 and 2-18, it is noted that TB1, TB2, TB3 and TB4 are "screw type" connectors, allowing the user to wire to the terminal board with discrete connections. If desired, mass termination of the control connections can be accomplished by utilizing the (optional) 50 pin connector, J1. All connections shown for TB1, TB2, TB3 and TB4 are available on connector J1. Using connector J1 for control interfacing instead of TB1, TB2, TB3 and TB4 allows an additional advantage of providing mass termination.

The destinations for control wiring from TB1, TB2, TB3, TB4 and J1 of the terminal board, to the control modules for axis 1, axis 2 and axis 3 servo amplifiers are shown in figure 2-20. In this figure, control wiring from the terminal board to axis 1 (4) is given as an example. The wiring for axis 2 (5) and axis 3 (6) (TB2 and TB3 respectively) is similar.

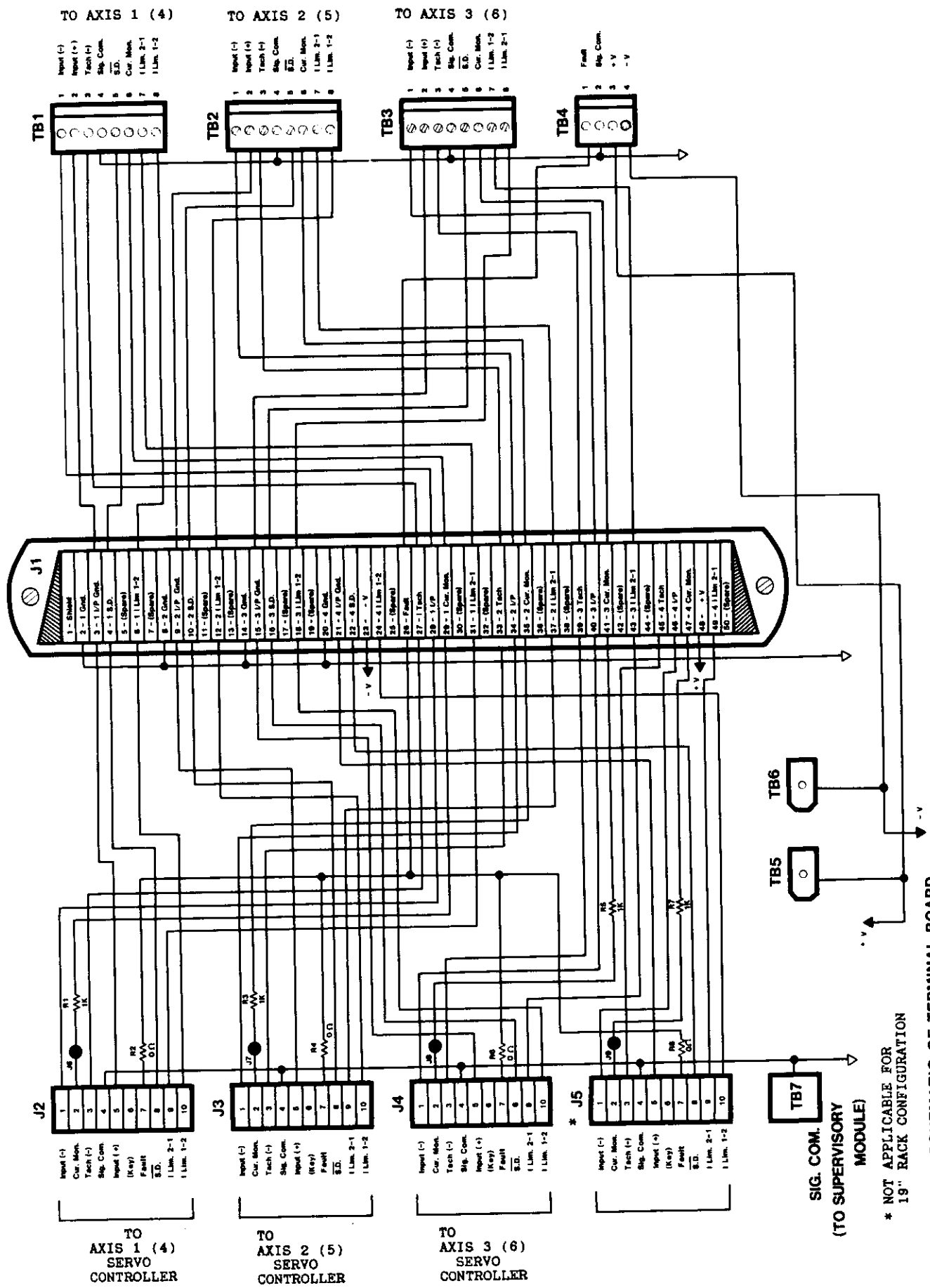

FIGURE 2-17: SCHEMATIC OF TERMINAL BOARD

* NOT APPLICABLE FOR 19" RACK CONFIGURATION

FIGURE 2-17: SCHEMATIC OF TERMINAL BOARD

CHAPTER 2

TERMINAL BOARD
(AXIS 4, 5, 6)
(TYPICAL)

TERMINAL BOARD
(AXIS 1, 2, 3)
TB1 TB2 TB3

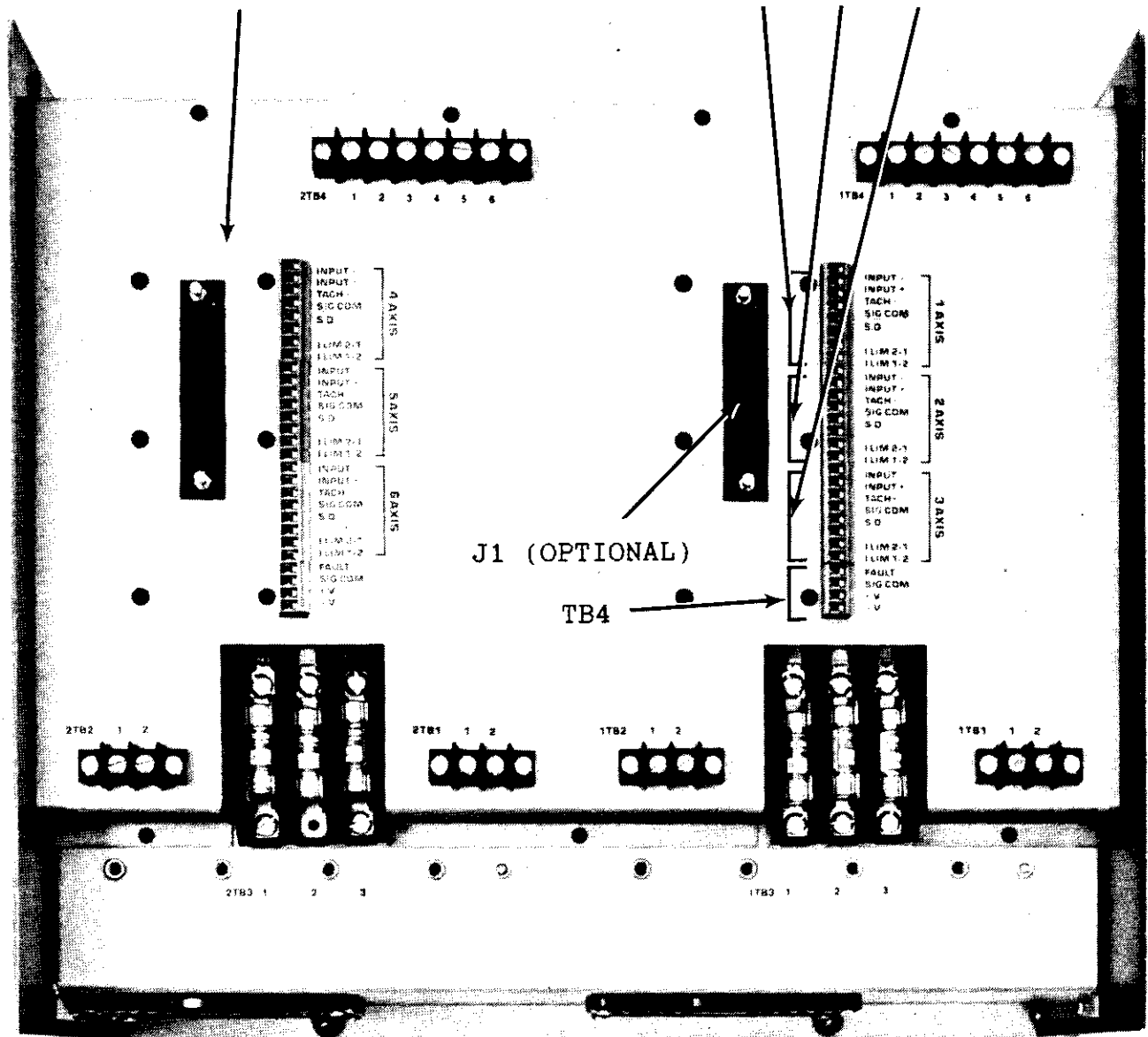
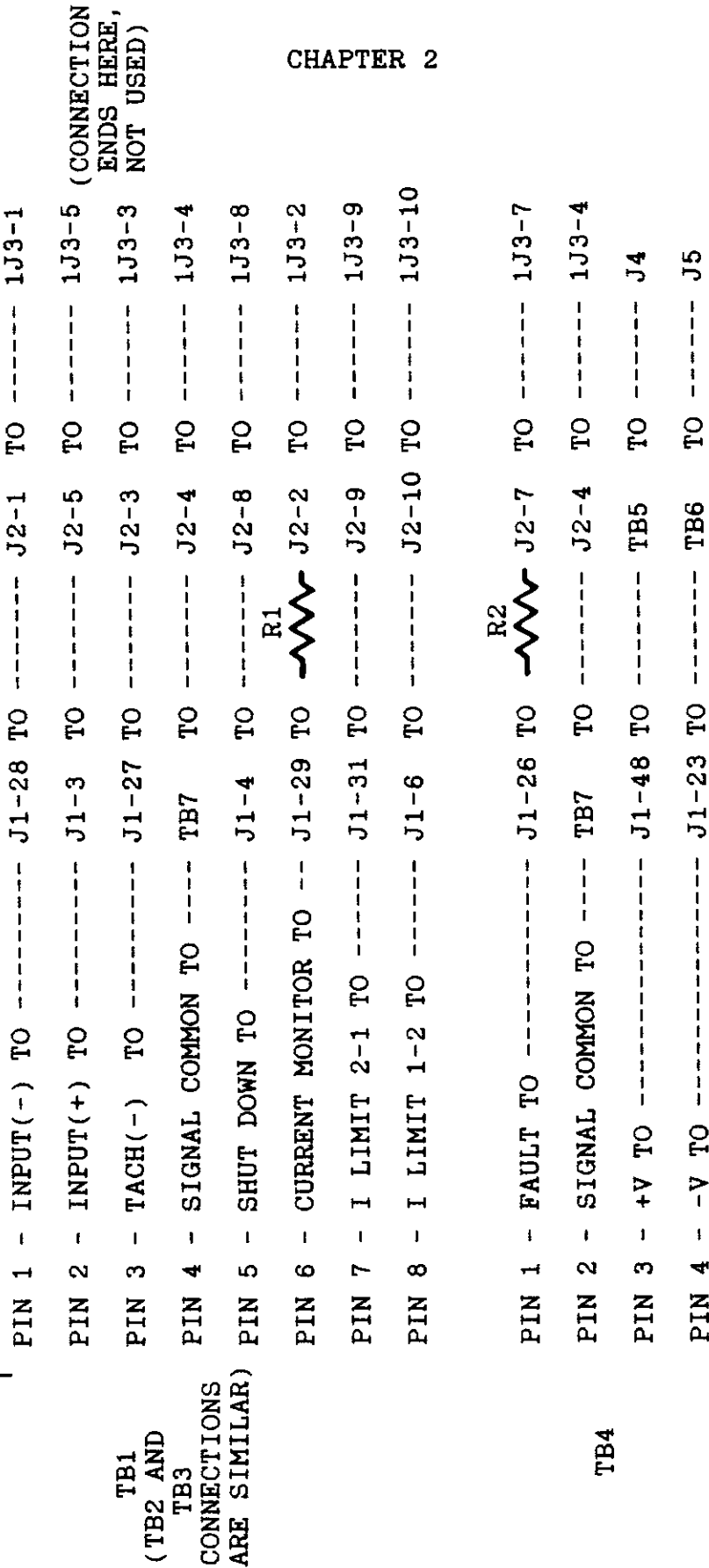

FIGURE 2-18: BACK VIEW OF 19" RACK

TERMINAL BOARD

SUPERVISORY MODULE



TB1
(TB2 AND TB3 CONNECTIONS ARE SIMILAR)

TB4

FIGURE 2-19: TERMINAL BOARD CONNECTIONS TO AXIS 1 (AXIS 2 AND 3 ARE SIMILAR)

**FIGURE 2-20: CONTROL CONNECTIONS DESCRIPTIONS FOR TERMINAL BOARD
TB1 (TB2 AND TB3 ARE SIMILAR)**

PIN 1, INPUT (-)	Speed command input signal to servo module. Nominal signal is usually between ± 10 volts. This signal is referenced to signal common (Pin 4, Sig. Com.)
PIN 2, INPUT (+)	Not used on 160V, 100QV or 80QV amplifier modules (no connection).
PIN 3, TACH (-)	Tach feedback input signal to servo module. Nominal signal is usually between ± 10 volts. However, signal range can be as high as ± 60 volts.
PIN 4, SIG. COM.	Reference point for input and output signals.
PIN 5, $\overline{S.D.}$	Shut down input for servo module. By pulling this input to signal common (1mA sinking through internal pull-up resistor to +12 VDC), the operation of the power stage of the servo module is inhibited.
CURRENT MONITOR	Connection for monitoring current feedback signal of servo module. The volt/amp ratio is 5 amp/volt for the 160V, 100QV or 80QV.
PIN 7, I LIMIT * 2-1	Directional current limit for servo module. By pulling this input to signal common (contact closure only) power flow to motor from 1TB4 (2TB4) point 2 to point 1 is limited to near zero.

FIGURE 2-21: CONTINUED

PIN 8, I LIMIT * Directional current limit for
1-2 servo module. By pulling this
 input to signal common (contact
 closure only), power flow to motor
 from 1TB4 (2TB4) point 1 to point
 2 is limited to near zero.

TB4

PIN 1, FAULT Output signal for alarming
 abnormal condition on servo
 module. This output is capable of
 pulling a load connected at +35
 VDC maximum to signal common (30
 mA maximum sinking).

* See figure 3-7

CHAPTER 3

SECTION 3-1 INSTALLATION AND START-UP

CAUTION: HIGH VOLTAGES EXIST ON ALL TRANSISTOR CASES ASSOCIATED WITH THE POWER STAGE

Before attempting to install or remove any of the servo amplifier modules or the supervisory module from the 19" rack, make sure the following steps are taken:

1. All input power to the 19" rack is TURNED OFF.
2. Allow at least two minutes to elapse (from the time power is turned off) BEFORE REMOVING THE DUST COVER FROM THE 19" RACK.
3. Disconnect "white" power connectors (J1 and J2) from ALL servo modules and supervisory modules.

(See figure 3-1 for additional information.)

WARNING: Damage to a servo amplifier module or supervisory module due to improper handling during installation or removal nullifies warranty.

Mounting dimensions for the 19" rack are shown in figure 3-2. Mounting is accomplished with eight #10-32 bolts.

Mounting of the servo modules and the supervisory modules to the 19" rack is accomplished with two captive screws located at the bottom of each module. These captive screws insert into the holes located on the mounting surface of the 19" rack as shown in figure 3-3.

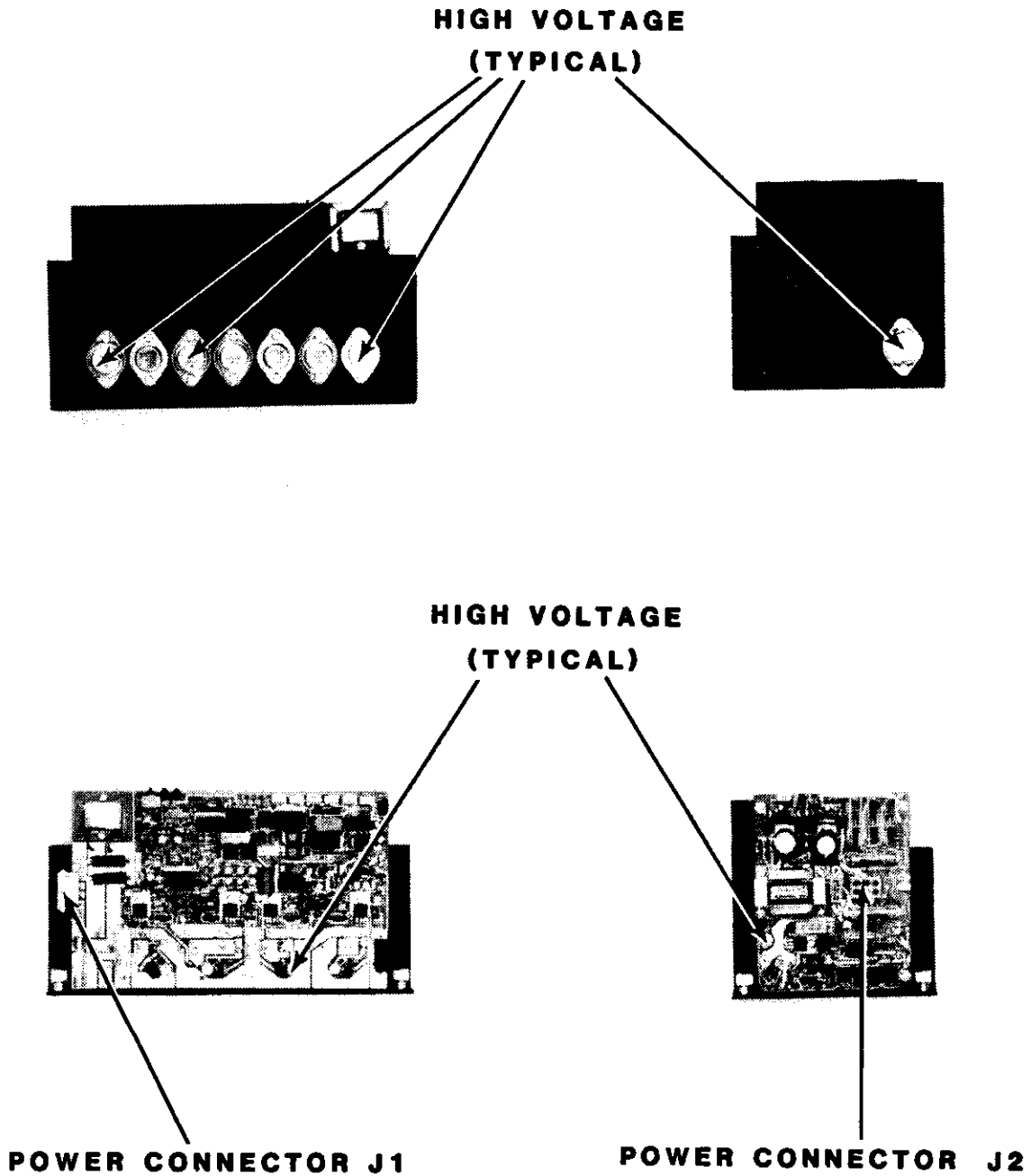

**FIGURE 3-1: LOCATIONS OF HIGH VOLTAGE ON SUPERVISORY AND SERVO
MODULES DURING OPERATION**

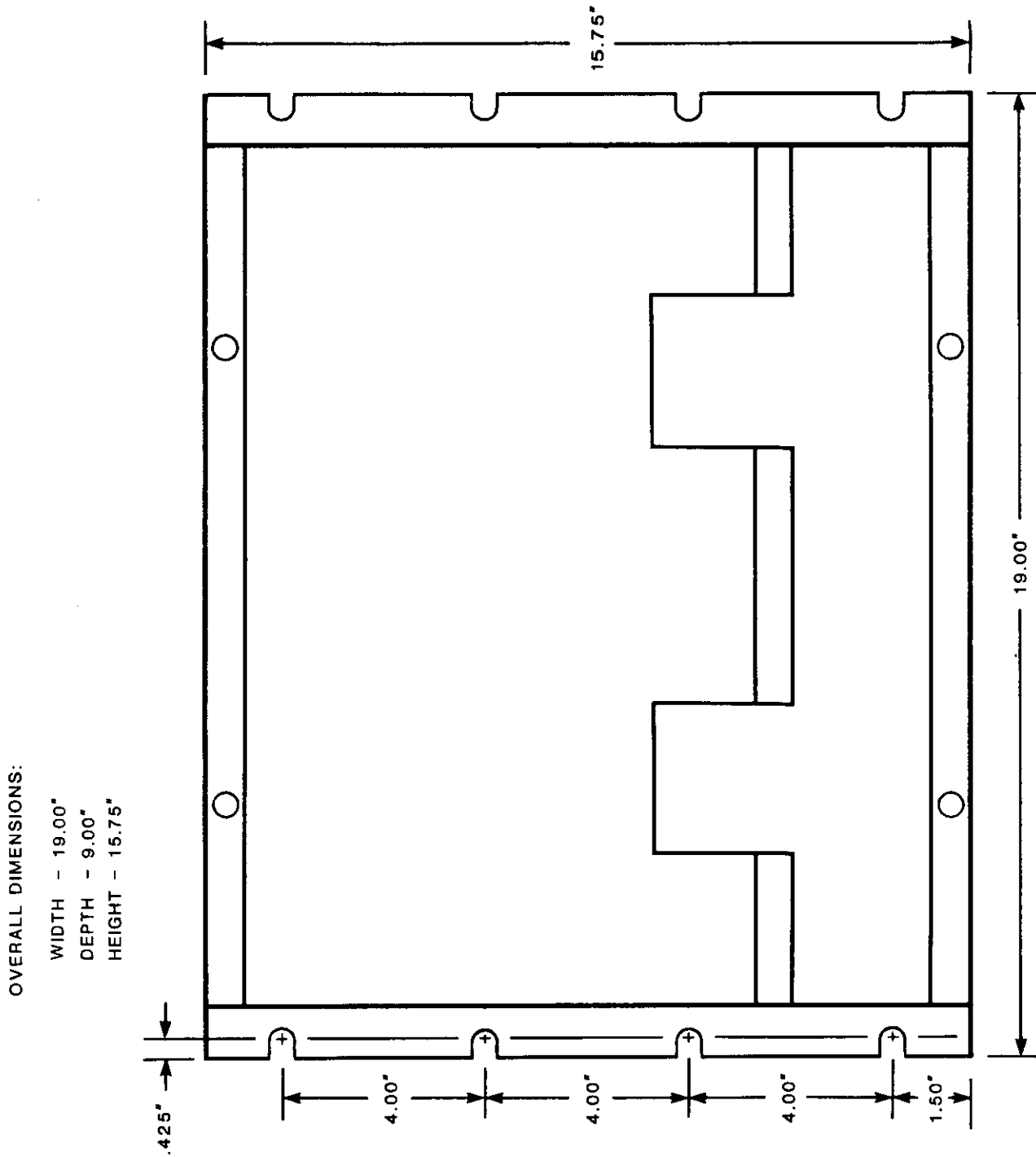

FIGURE 3-2: BACK VIEW MOUNTING SPECIFICATIONS FOR 19" RACK

CAPTIVE SCREWS
(HOLDING SERVO MODULES
AND SUPERVISORY MODULES
TO 19" RACK)

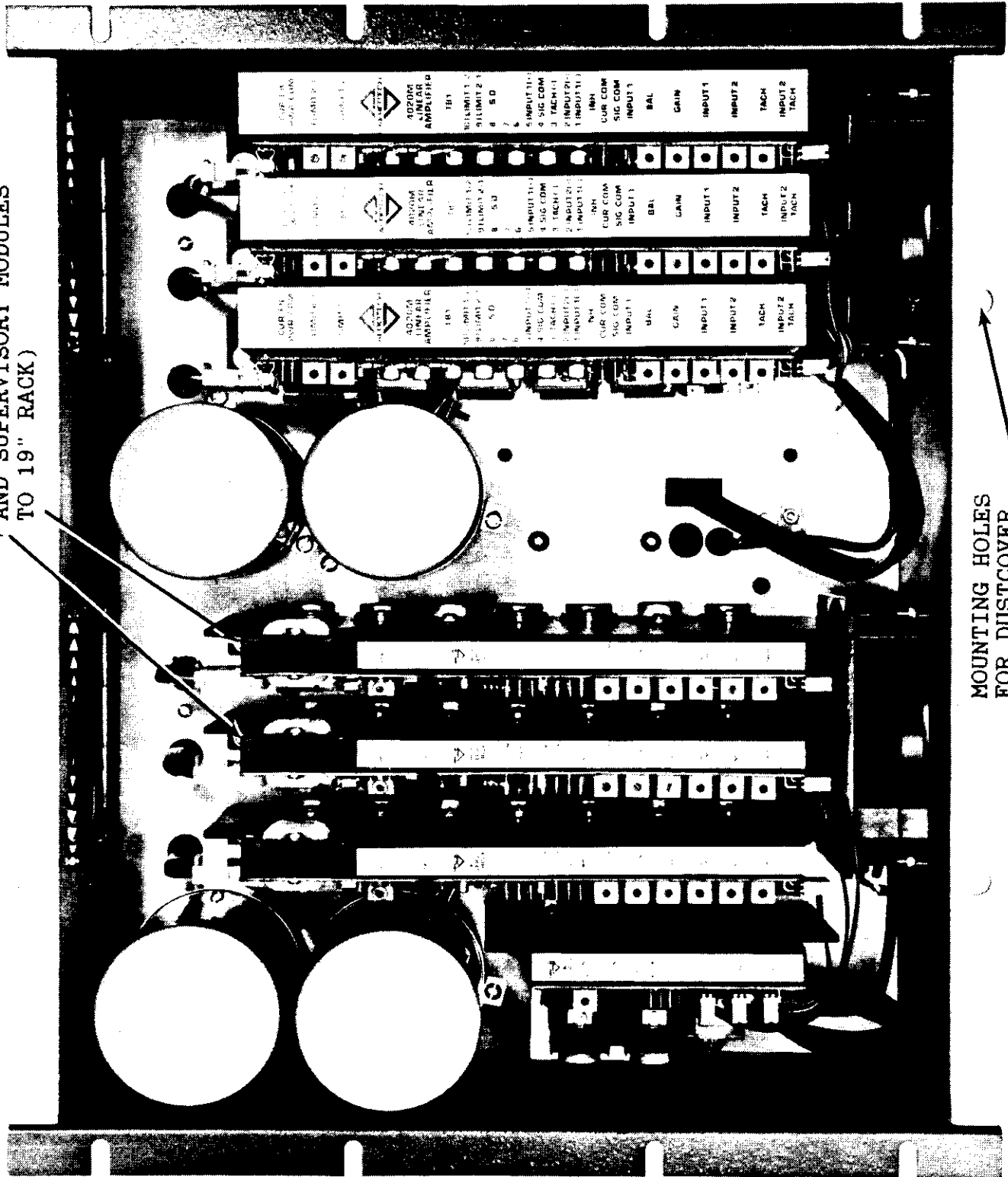

FIGURE 3-3: FRONT VIEW MOUNTING SPECIFICATIONS FOR 19" RACK

CHAPTER 3

Control connections between the servo modules, the supervisory module and the terminal board, are made with ribbon cables as shown in figure 2-16 (B). The location and destination of each ribbon cable can be determined by referring to these figures.

Input power connections to the 19" rack are made at terminal blocks 1TB1 (2TB1), 1TB2 (2TB2) and 1TB3 (2TB3) as shown in figure 2-18. The 160V SERIES, 100QV SERIES and 80QV SERIES Amplifier and Supervisory Module require a different set of input power connections to 1TB1 (2TB1) and 1TB3 (2TB3), due to their different DC bus voltage requirements. Figures 3-4, 3-5 and 3-6 show the input power arrangements for the 160V, 100QV and 80QV SERIES 19" rack, respectively. **IMPORTANT:** Earth ground (designated "GND") in figures 3-4, 3-5 and 3-6 must be connected as shown. Also note that power supply configurations C and D of figures 3-4, 3-5 and 3-6 must be ungrounded.

The locations for the motor power connections to the base plates are shown in figure 3-7. The technique for properly connecting the polarity of the motor power connections and motor tach connections to the 160V, 100QV and 80QV SERIES Base Plate is described below:

1. Spin motor shaft CW (looking into flange). Note the polarities of the motor power leads and tach leads.
2. A minus (-) signal on Input (-) connections to the terminal board will cause the motor to spin CW (looking into flange) if:
 - a.* The "+" lead of the motor is connected to 1TB4 (2TB4) point 2, with the "-" lead connected to point 1.
 - b. The "+" lead of the tach is connected to tach (-), axis 1 of the terminal board, with the "-" lead connected to signal common (sig. com.).

* The connections described above are similar for all six axes. (See figure 3-7.)

CHAPTER 3

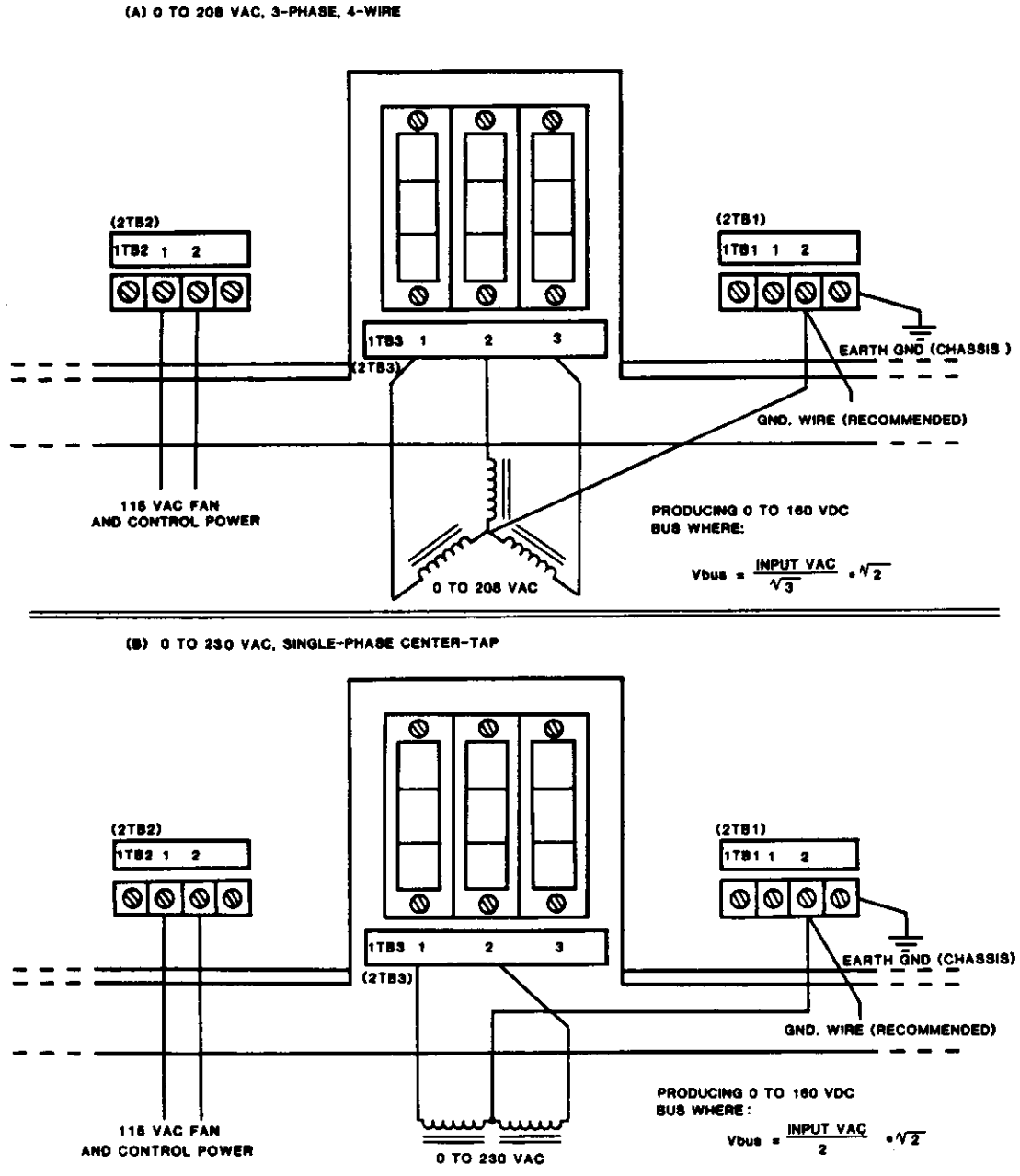
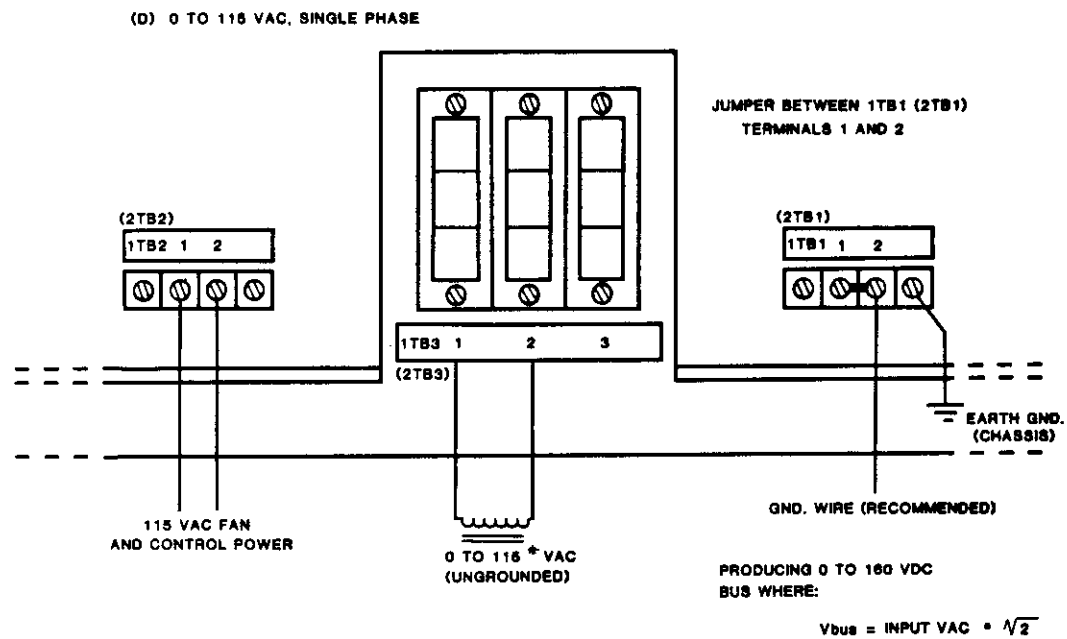
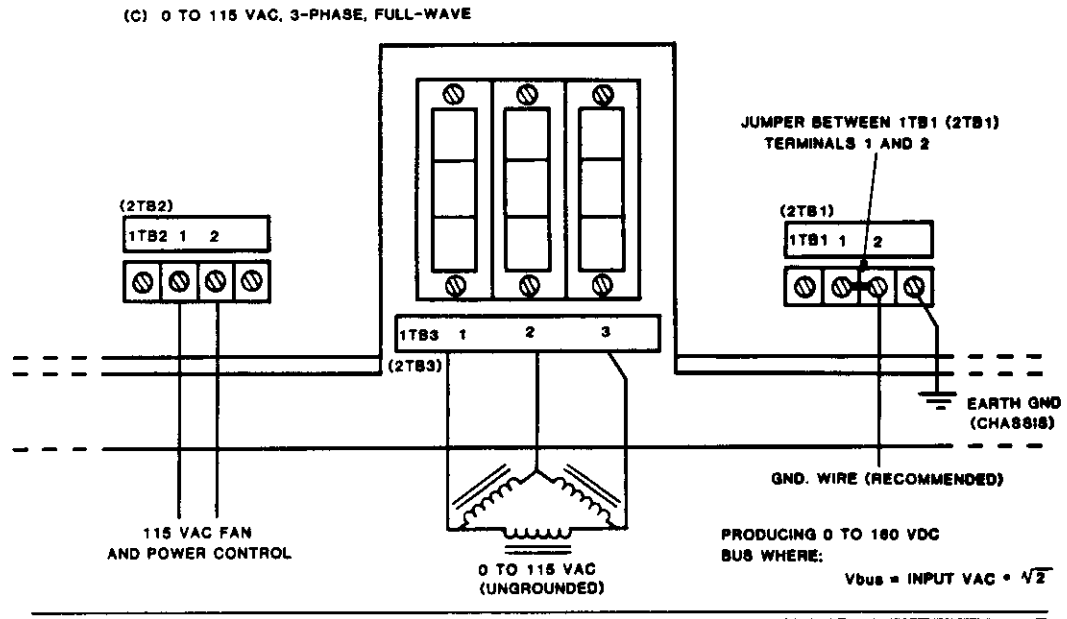

FIGURE 3-4: INPUT POWER CONFIGURATION FOR THE 160V SERIES 19" RACK

CHAPTER 3



* **WARNING:** DO NOT USE STANDARD 115 VAC OUTLET POWER

FIGURE 3-4: CONTINUED

CHAPTER 3

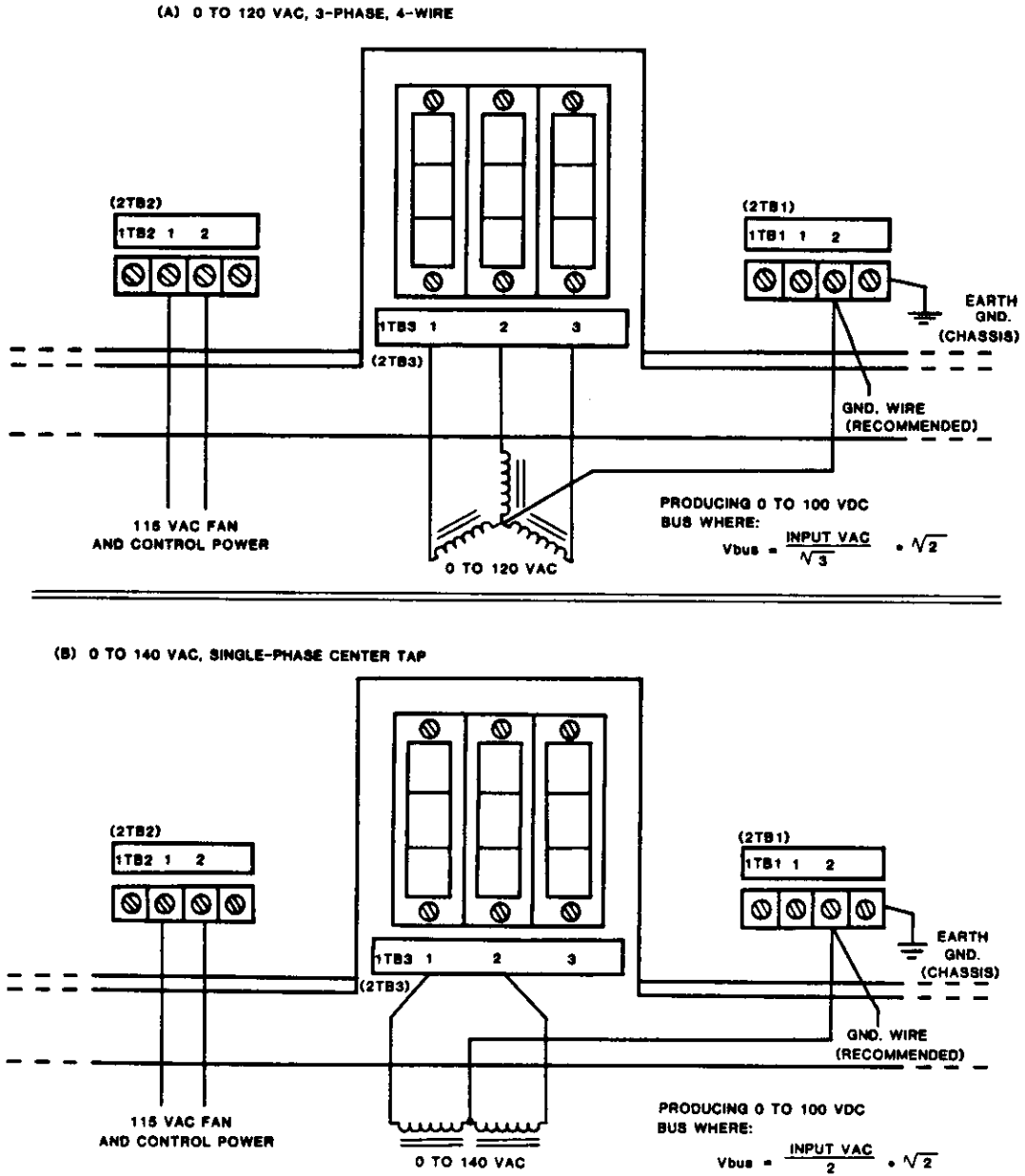

FIGURE 3-5: INPUT POWER CONFIGURATION FOR THE 100QV SERIES 19" RACK

CHAPTER 3

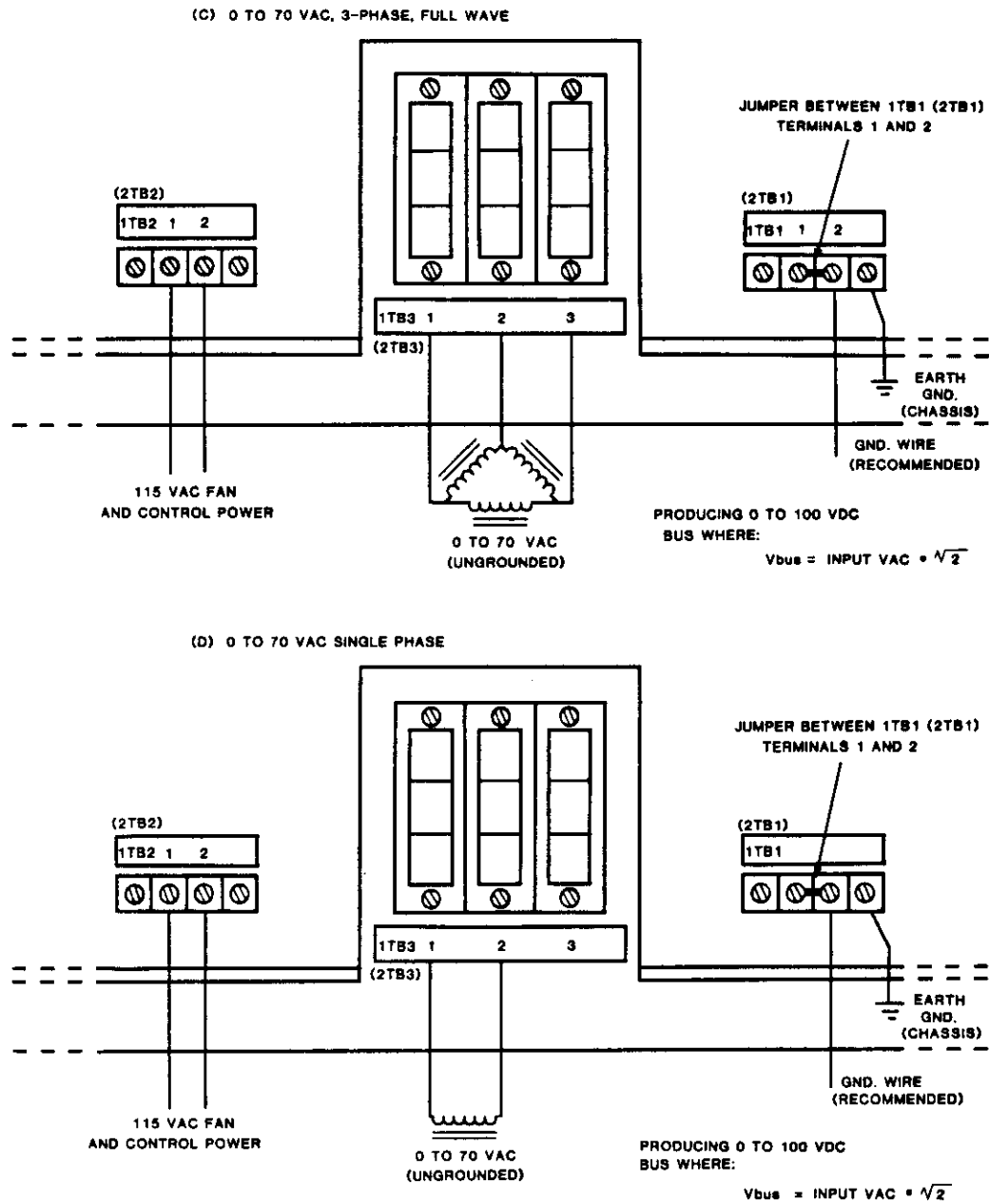

FIGURE 3-5: CONTINUED

CHAPTER 3

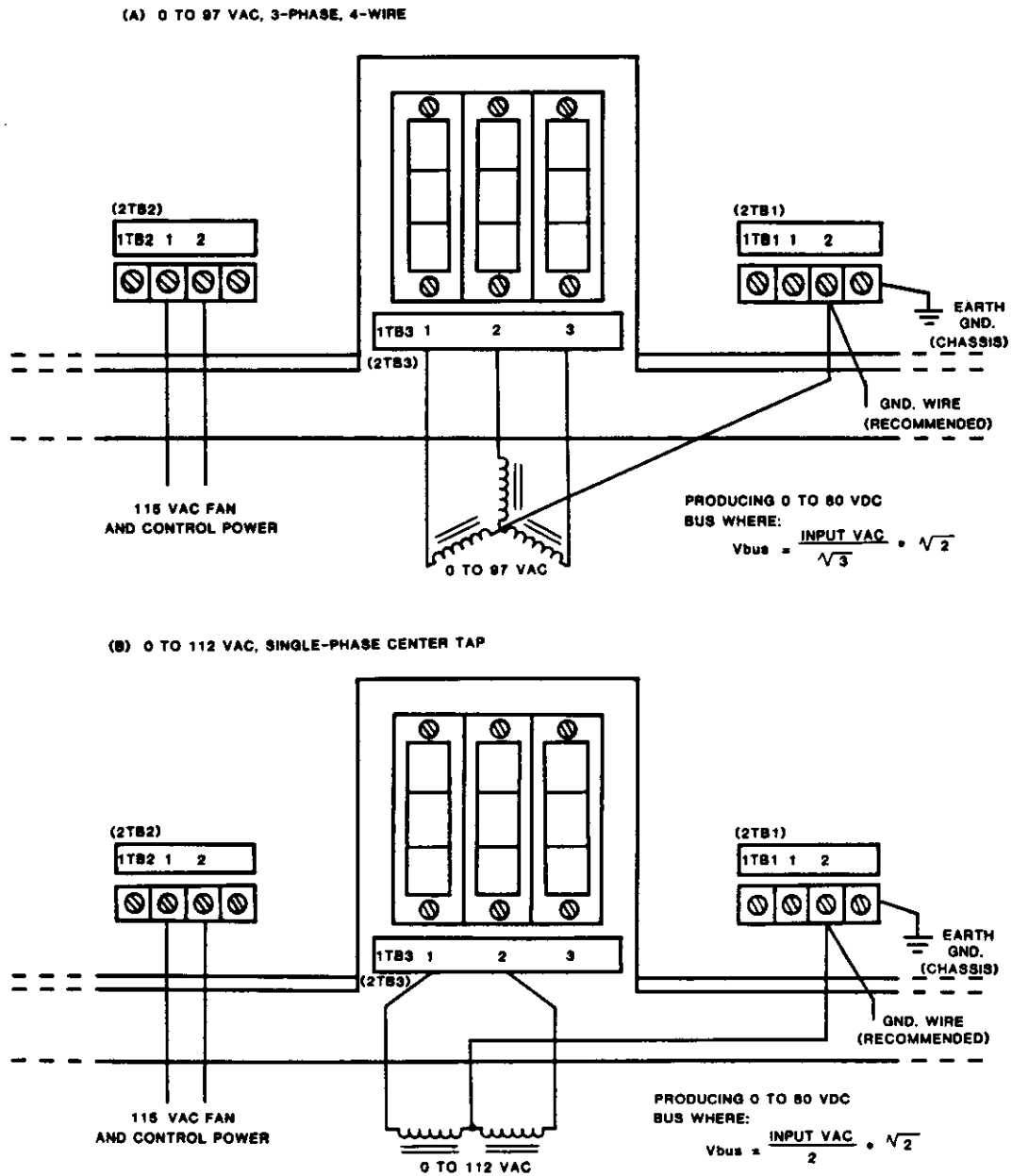

FIGURE 3-6: INPUT POWER CONFIGURATIONS FOR THE 80QV SERIES 19" RACK

CHAPTER 3

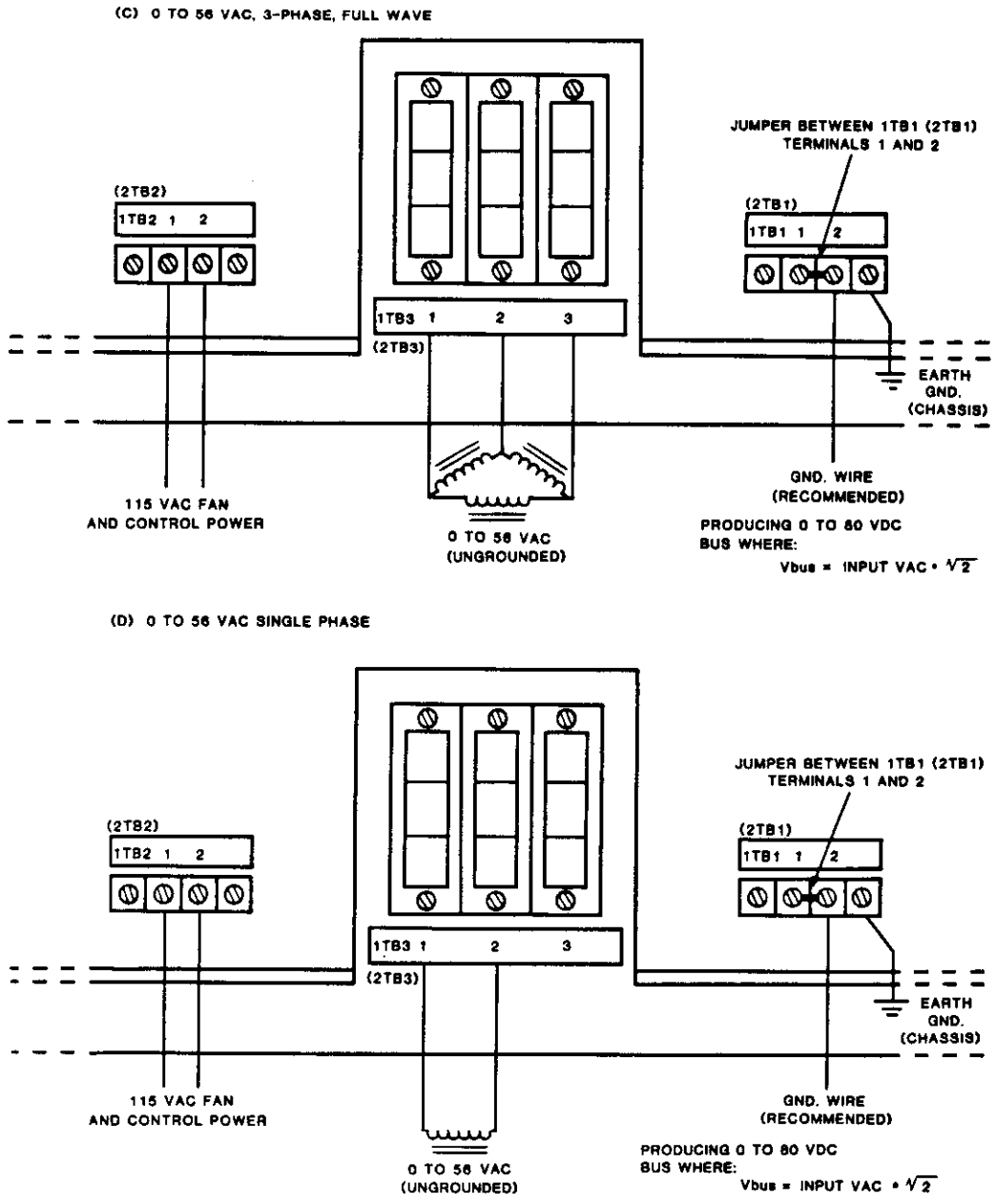

FIGURE 3-6: CONTINUED

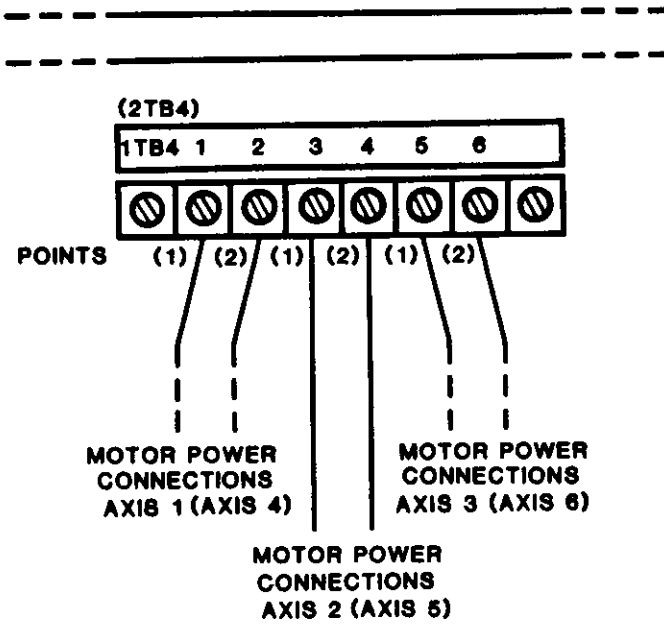

FIGURE 3-7: LOCATIONS FOR MOTOR POWER CONNECTIONS FOR AXES 1, 2, 3, 4, 5 AND 6

CHAPTER 3

When the supervisory and amplifier modules have been installed on the 19" rack, and the control and power wiring to 19" rack has been completed, the servo module and supervisory module are ready to be adjusted for operation within the system.

Note in figure 2-5 the locations of the six control pots and seven testpoints on the servo module. Set the pots to the following positions:

1. Current Limit (Cur. Lim.) pot to be adjusted to midway position.
2. Gain (Gain) pot to be turned completely CW.
3. Input (Input) pot to be turned completely CW.
4. Tach (Tach) pot to be turned completely CW.
5. Dynamic Current Limit (Dyn. Cur. Limit) pot to be turned completely CCW.
6. Balance (Bal.) pot to be adjusted to midway position.

Referring to figure 2-12, turn the Shunt pot completely CW on the supervisory module.

NOTE: Make certain that motor shaft is mechanically decoupled from drive system, therefore avoiding possible damage to system.

If the servo modules is being used in a position loop, temporarily disconnect the input signal. This will allow the servo module to work only in the rate loop.

Apply power to the 19" rack. If the motor(s) races, disconnect power and reverse the tach connections to the given motor at the appropriate terminal board on the back of the 19" rack.

With power again applied, adjust the balance pot until the motor(s) comes to a complete stop.

Disconnect power, reconnect the input signal and recouple the motor shaft to the drive system. Be sure the input signal is at zero volts (ie., make sure the position loop controller is in "home" position).

Now reapply power. If the position controller indicates that the system is out of "zero" (or "home") position, readjust the balance pot of the given servo module.

NOTE: The balance pot is capable of cancelling only small offsets (± 15 mV) in the pre-amplifier or on the input signal. If adjusting the balance pot fails to bring the system to zero position, then the input signal is exhibiting too much offset voltage.

Position commands can now be applied to the system. Program the position controller so that the motor accelerates and decelerates to some position, stops, and then returns to "home" position. Make the cycle time in which this event occurs approximately 2 seconds. With an oscilloscope, monitor the tach testpoint with respect to signal common (refer to figure 2-5).

SECTION 3-2 ADJUSTING INPUT AND TACH POTS FOR POSITION LOOP STABILITY

Motor overshoot, when present in a closed position loop system, can be very detrimental to position loop accuracy. Care must be taken in the fine tuning adjustments of the tach, input, and gain pots, to prevent the problem from occurring.

Photograph A (following page) of figure 3-8 shows a typical deceleration interval for a motor (in this case, the 1410-02 motor used with the 160V servo module), being commanded to decelerate to zero speed

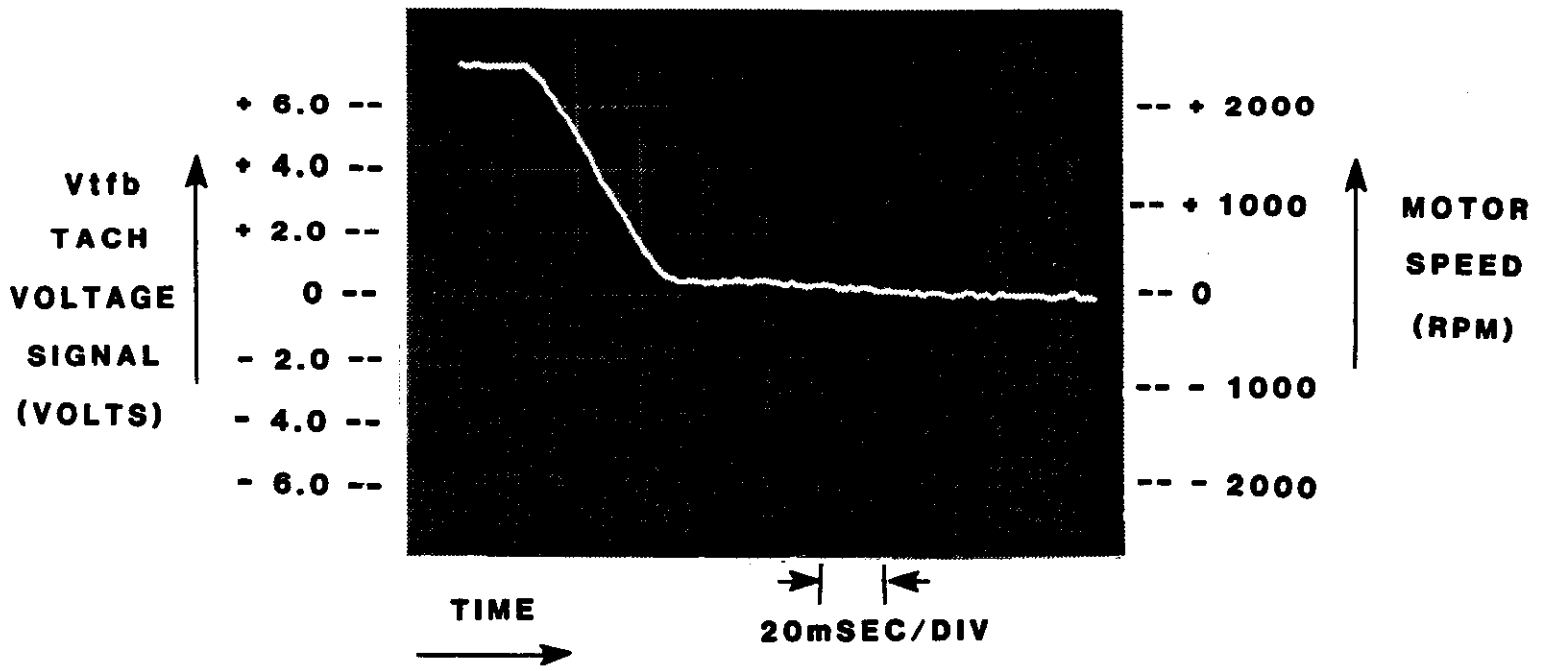

(A)

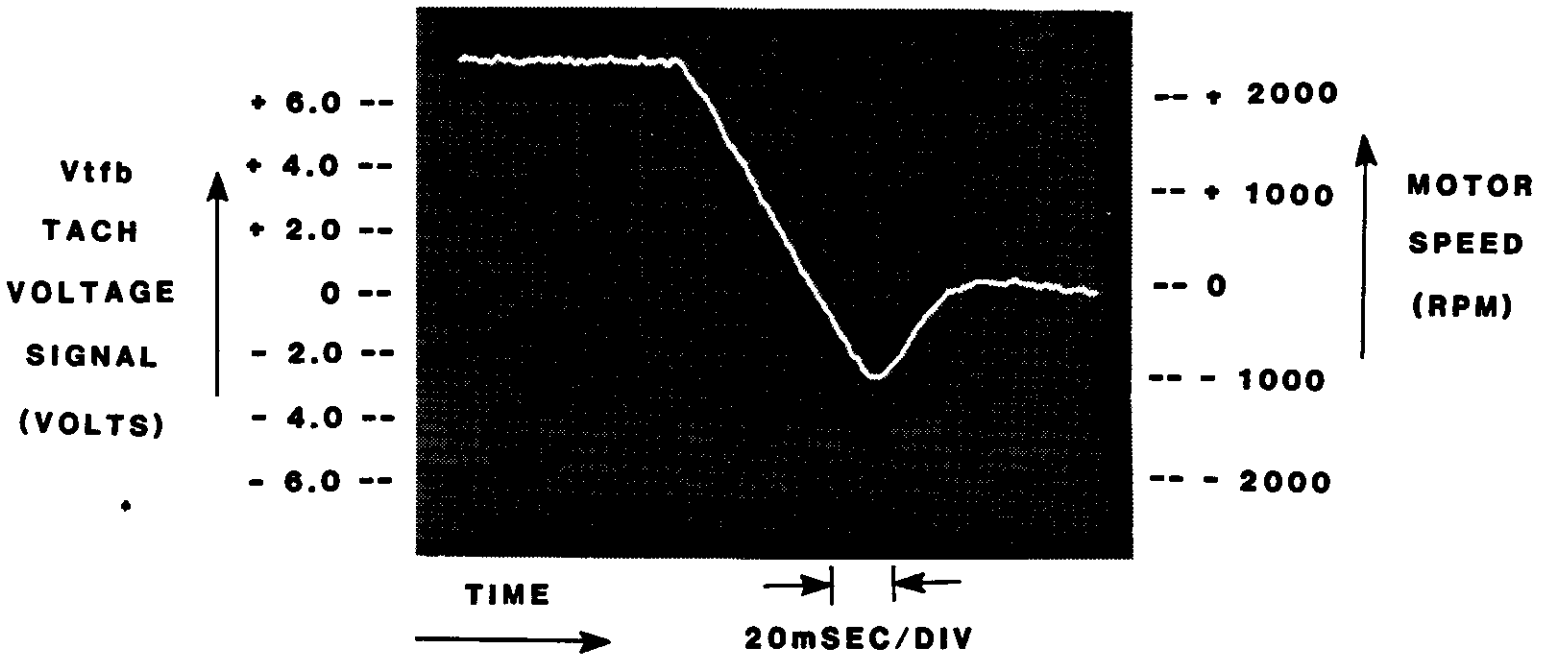

(B)

FIGURE 3-8: ADJUSTING INPUT AND TACH POTS FOR POSITION LOOP STABILITY

by a position controller. Note that the motor's speed (or tach voltage), ramps smoothly to zero speed, without ever crossing zero. This photograph shows optimum motor response during deceleration.

Photograph "B" of figure 3-8 shows a deceleration interval where the tach gain is set too low (or the input gain is set too high). Note that the tach voltage crosses zero. In this case, the motor "over-shoots" its designated "home" position, but eventually settles into position.

A good rule of thumb for adjusting motor deceleration response is to initially set the input and tach pots full CW. Then slowly turn the tach pot CCW until minimum motor deceleration time is achieved without over-shooting.

SECTION 3-3 LIMITING MAXIMUM ALLOWABLE MOTOR CURRENT WITH RESPECT TO MOTOR SPEED

All DC PM motors have a limitation on the magnitude of peak current that can be tolerated at high speeds. This limitation becomes noticeable when a motor is matched to a servo module whose peak current rating is four (or more) times that of the continuous current rating of the motor. A good example of this is the 160V servo amplifier module being matched with the Aerotech 1410-02 motor (400 Oz-In continuous).

With the use of the dynamic current limit circuit, high current can be delivered to a motor at low speeds while contouring (or limiting) this maximum current at higher speeds. Figure 2-9 shows graphically the effect of this circuit on all four quadrants of motor operation.

CHAPTER 3

Photograph "A" of figure 3-9 (following page) shows a typical acceleration current pulse (seen on the current feedback testpoint) with the dynamic current limit pot in the full CCW position (completely disabled).

Photograph "B" of figure 3-9 (following page) shows a typical acceleration current pulse with the dynamic current limit pot in the full CW position. Note that the "contouring" clamp on a deceleration current pulse would be similar, but would instead be on the left side of the pulse.

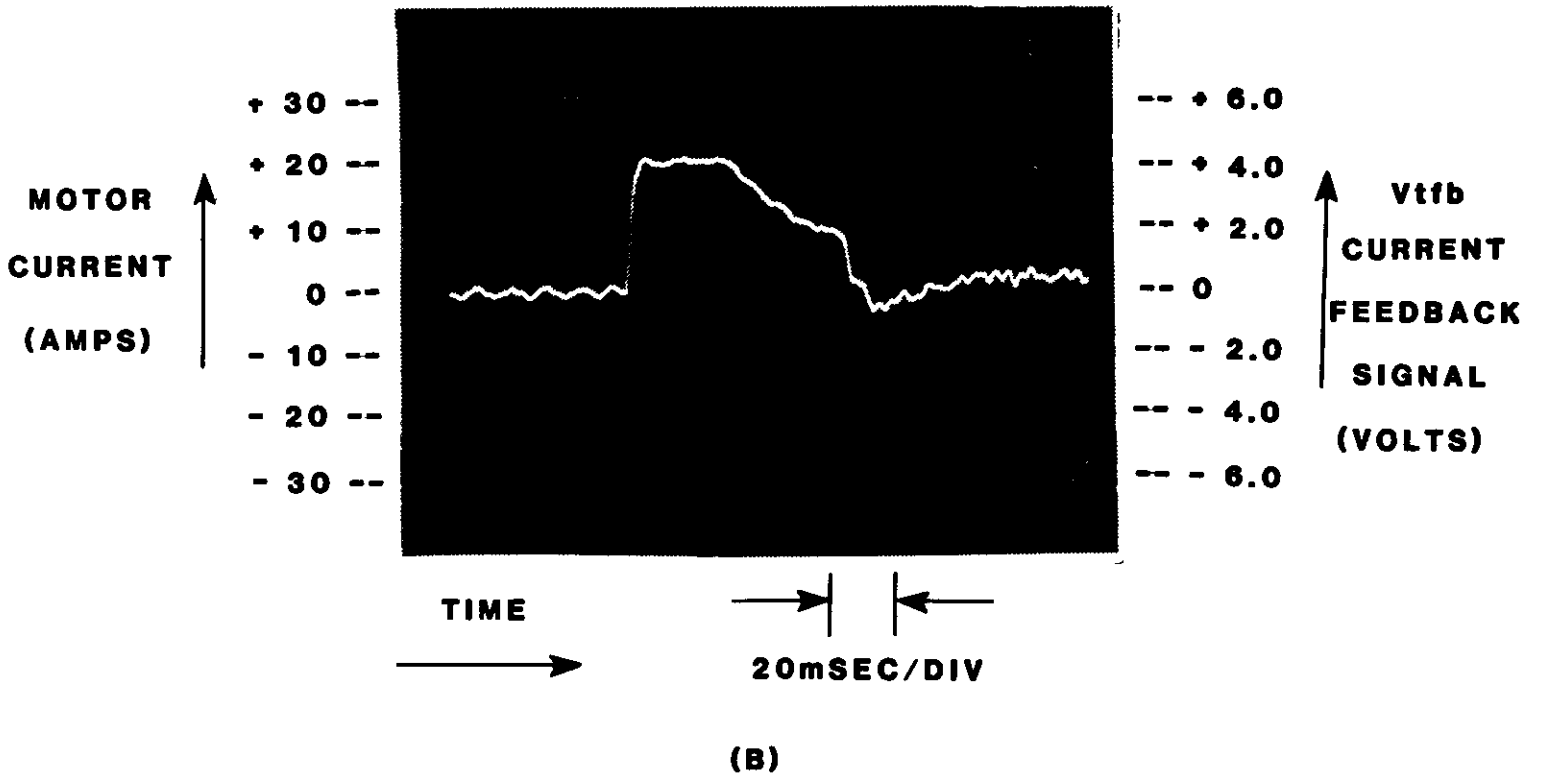
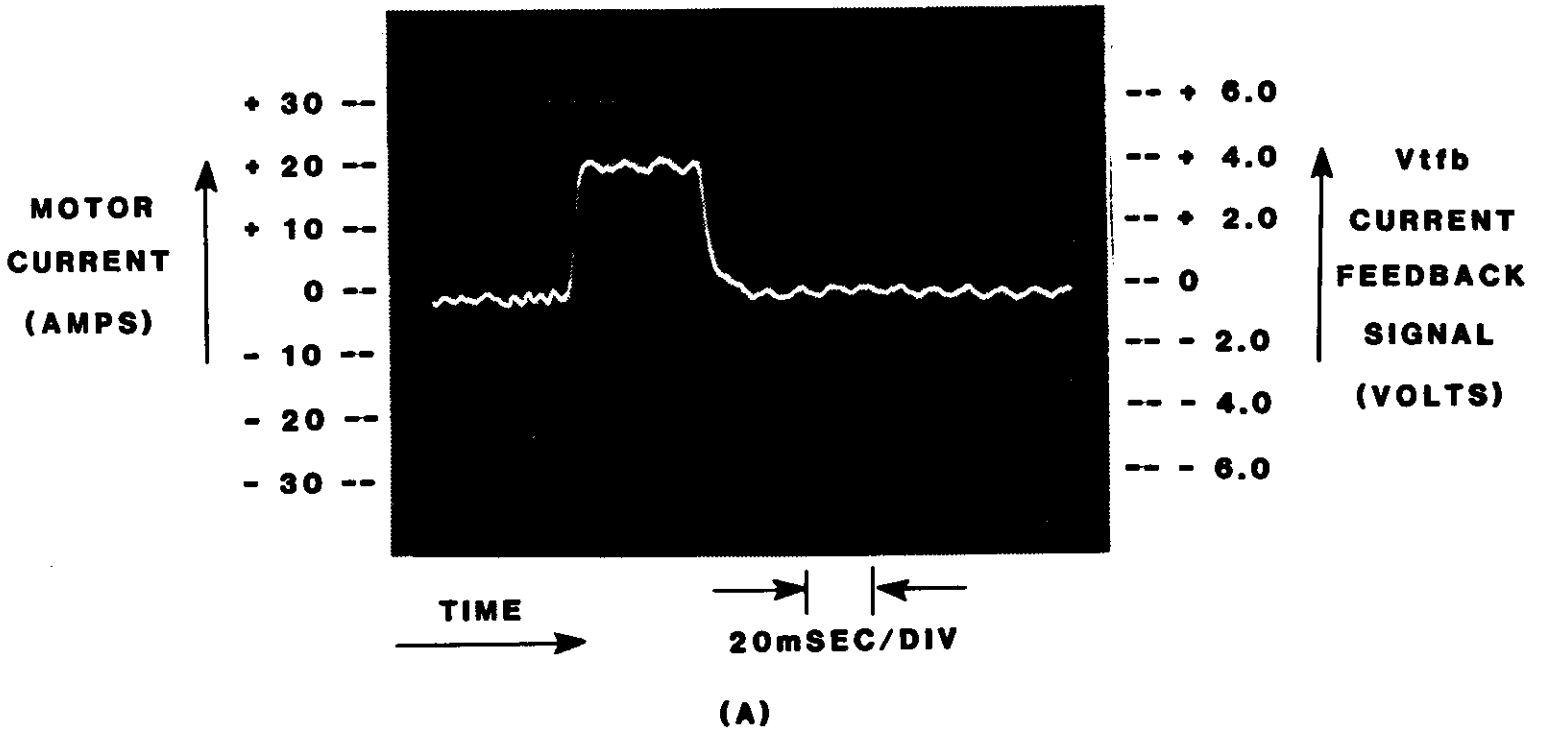

FIGURE 3-9: LIMITING MAXIMUM ALLOWABLE MOTOR CURRENT WITH RESPECT TO MOTOR SPEED

SECTION 3-4 MINIMIZING RIPPLE CURRENT

The magnitude of ripple current present on the current feedback testpoint of a given servo module, when the motor is running at a constant speed, is basically the product of two characteristics of that motor. They are:

1. The motor's armature inductance, which contributes to the servo amplifier switching ripple current on the current feedback signal.
2. The tach feedback ripple voltage (produced by the commutator of the tach), which is amplified by the pre-amplifier circuit, contributes to ripple on the current command signal.

It is the ripple from the tach signal on the current command signal that usually contributes to most of the excess I R heating in the motor.

Photograph "A" of figure 3-10 (following page) shows an optimum level of peak to peak ripple current for the 1410-02 Aerotech SERIES motor running unloaded, at constant speed. (This RMS ripple should be no more than 10-20 % of the continuous current rating of the motor.)

Photograph "B" of figure 3-10 (following page) shows an excessive level of ripple current, due to excessive gain in the pre-amplifier, for the motors running under the same conditions as in photograph "A".

CHAPTER 3

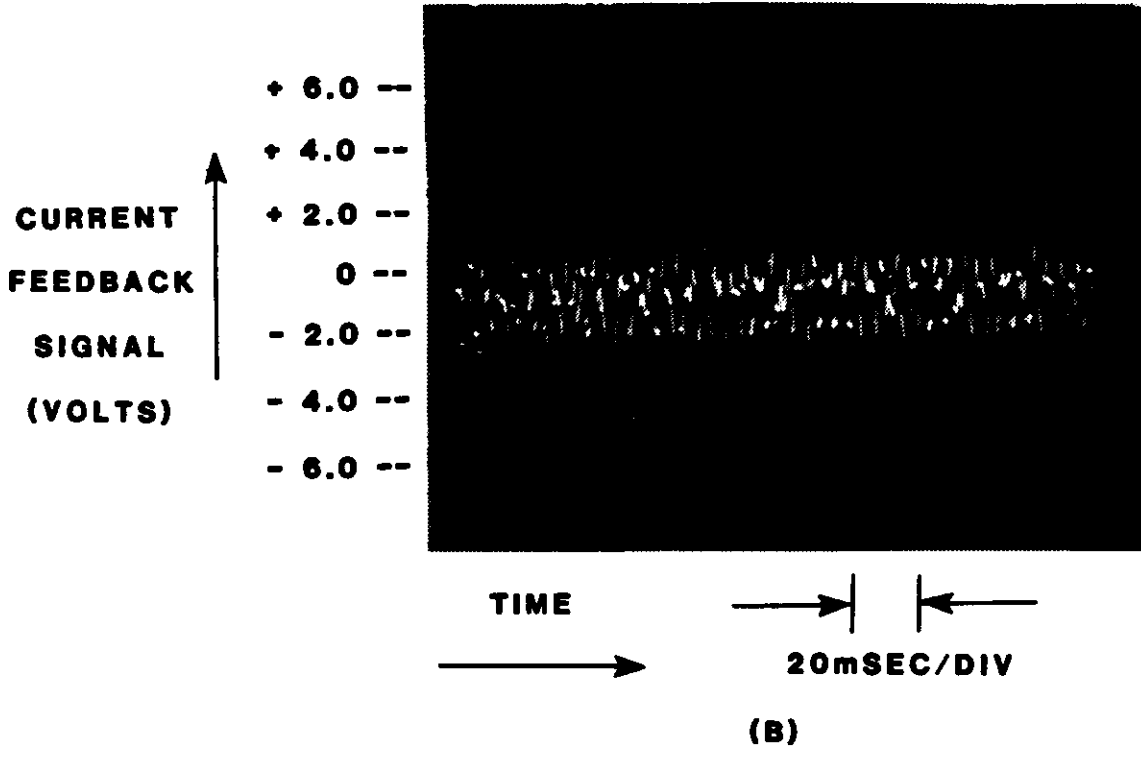
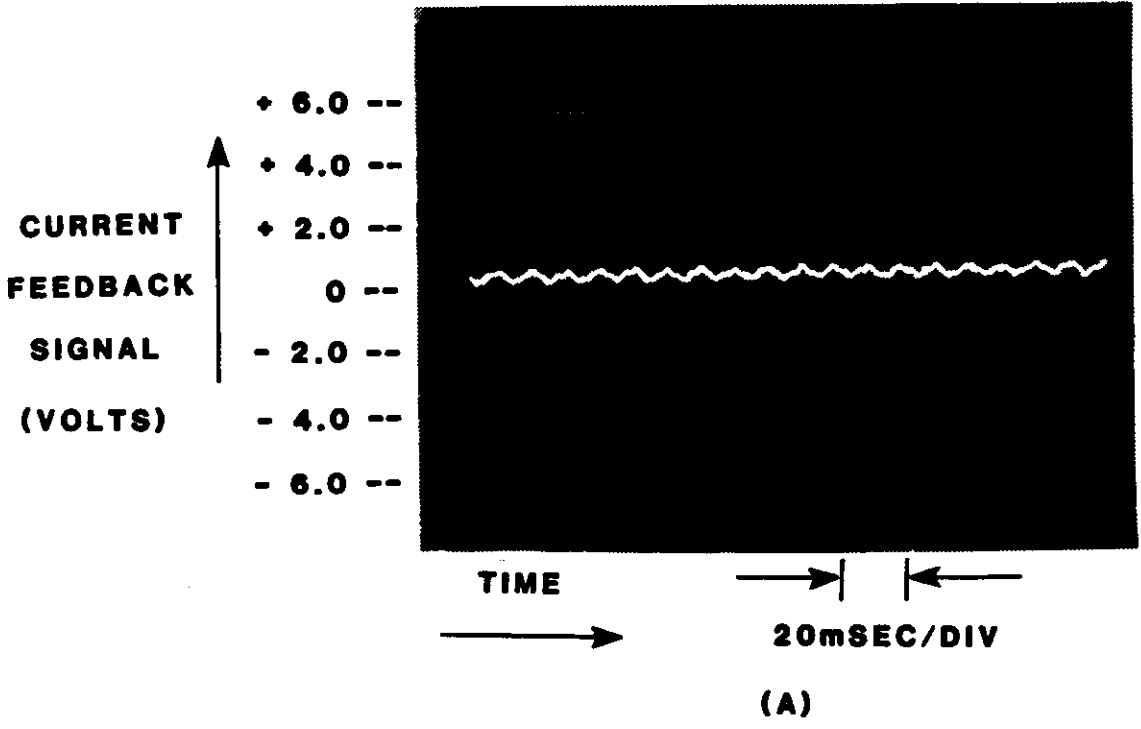

FIGURE 3-10: ADJUSTABLE GAIN POT TO MINIMIZE RIPPLE CURRENT IN MOTOR

CHAPTER 3

Finally, with the motor(s) slewing back and forth, slowly turn the shunt adjust pot on the supervisory module CCW until the shunt LED begins to "blink". Then, turn back the pot about 1/10 turn, CW.

NOTE: Fluctuation in input line voltage may energize the shunt circuit. Be sure to adjust this pot to make allowance for this potential situation.

With these adjustments complete, the three axis base plate is ready for full operation within the system.

CHAPTER 4

SECTION 4-1 TROUBLESHOOTING (19" RACK)

Unless otherwise noted, refer to figure 2-16 A and B

WARNING: BEFORE ANY ACTION IS TAKEN, AND UNLESS OTHERWISE SPECIFIED, TURN OFF POWER

<u>SYMPTOM</u>	<u>POSSIBLE CAUSE</u>	<u>SOLUTION</u>
Fan does not operate when input power is applied	Improper power connections on 1TB2 (2TB2) of 19" rack	Check for 112 VAC between 1TB2 (2TB2) terminals 1 and 2 (see figures 3-4, 3-5 and 3-6)
DC bus voltages are not at levels dictated by test procedure stated in "Installation and Start-up"	Improper power connections on 1TB3 (2TB3) of 19" rack	Refer to figures 3-4, 3-5 and 3-6 for input power connection arrangements to the 19" rack. With a voltmeter, verify that these voltages exist
Input power fuse F1, F2 and/or F3 on 1TB3 (2TB3) of 19" rack open when power is applied	Jumper connection on 1TB2 (2TB2) terminal 1 and 2 may not have been removed as dictated by figures 3-4 A and B, 3-5 A and B and 3-6 A and B.	Refer to figures mentioned if applicable. Also, make sure that the jumper is removed, if applicable
Fault LED on supervisory module energizes briefly, during acceleration intervals of the servo motors	When using center tapped or 4-wire input power configurations such as those shown in figures 3-4, 3-5 and 3-6, A and B,	Check the continuity of input fuses F1, F2 and F3 on 1TB3 (2TB3) of the 19" rack. Recheck the AC voltages at 1TB3 (2TB3).

CHAPTER 4

<u>SYMPTOM</u>	<u>POSSIBLE CAUSE</u>	<u>SOLUTION</u>
	proper DC bus levels can be generated at no load with just a single phase operating	(Above)

SECTION 4-2 TROUBLESHOOTING (SERVO AMPLIFIER MODULES)

Unless otherwise noted, refer to figure 2-5.

WARNING: BEFORE ANY ACTION IS TAKEN, AND UNLESS OTHERWISE SPECIFIED, **TURN OFF POWER.**

<u>SYMPTOM</u>	<u>POSSIBLE CAUSE</u>	<u>SOLUTION</u>
No power to motor	Input fuses on 19" rack are open	See section 4-1
	Motor fuse (F1) is open	Remove fuse and check for continuity
	Input shutdown (SD), located on the given terminal board of the 19" rack pulled to signal common	Temporarily remove connection to restore power
	Supervisory module inhibiting servo module(s) due to high or low Vbus or control under voltage conditions	See section 4-3
Motor is racing	Tach polarities are reversed	Reverse polarities of tach connections on the given terminal board of the 19" rack

CHAPTER 4

<u>SYMPTOM</u>	<u>POSSIBLE CAUSE</u>	<u>SOLUTION</u>
	No tach connection	Check tach testpoint with respect to signal common. With motor racing, tach voltage signal should be present at this testpoint. If no signal is present, check for continuity on tach connection of the ribbon cable between the servo module and the supervisory module, and also for continuity on tach connection of the ribbon cable between the supervisory module and the terminal board (see figure 2-6, 2-13 and 2-17)
Current trip LED remains energized (unable to reset through reset pushbutton). Current trip shutdown circuit activated	Short circuit exists on motor terminals	Disconnect motor leads on the 19" rack. Reapply power and depress reset button. If LED stays energized, the servo module is defective. Return to Aerotech for repair (see section 5-1)
RMS limit LED is energized, but motor is still receiving power from servo module. RMS current limit circuit activated	Motor armature is frozen	Temporarily decouple motor armature from drive system. If LED de-energizes, problem is with the motor

CHAPTER 4

<u>SYMPTOM</u>	<u>POSSIBLE CAUSE</u>	<u>SOLUTION</u>
Motor is sluggish in response to speed command input	I limit 1-2 or I limit 2-1 inputs (located on the appropriate terminal board of the 19" rack) activated by limit switches	Temporarily remove connections to restore power
	Current limit (Cur. Lim.) pot set to clamp at too low a value	Turn current limit pot CCW, to increase the current clamp level
Motor will not lock system in "home" position (position loop control)	Excessive DC offset on input signal to servo module	Adjust Balance (Bal.) pot to bring system into "home" position. If system does not respond to this solution, then excessive offset exists on the speed command signal of the position controller
Motor overshoots when coming to rest (position loop control)	Gain not set properly	See section 3-2 for information on gain control adjustment in a position loop
Motor runs very hot	Gain set too high in servo module, causing excessive ripple current in motor	See section 3-4 for information on gain adjustment

CHAPTER 4

SECTION 4-3 TROUBLESHOOTING (SUPERVISORY MODULE)

Unless otherwise noted, refer to figure 2-12.

WARNING: BEFORE ANY ACTION IS TAKEN, AND UNLESS OTHERWISE SPECIFIED, TURN OFF POWER.

<u>SYMPTOM</u>	<u>POSSIBLE CAUSE</u>	<u>SOLUTION</u>
Fault LED does not energize for 2 seconds and then de-energizes when power is first applied to mounting base	Fuse F2 is open	Remove F2 and check for continuity
	Input fuses on 19" rack are open	See section 4-1
	Connector J2 is faulty	Remove J2 connection from supervisory module and check for 115 VAC between "Black" wire and "White" wire of J2. If voltage is not present, re-check input wiring on 19" rack
	+12 VDC control voltage regulators shorted	Temporarily disconnect ribbon cable connection on 1J1, 2J1 and 3J1. With J2 connected and input power applied, monitor ± 12 VDC test-points with respect to signal common. If ± 12 VDC is not present, replace supervisory module

<u>SYMPTOM</u>	<u>POSSIBLE CAUSE</u>	<u>SOLUTION</u>
Fault LED stays energized after power up	Shunt fuse F1 is open	If ± 12 VDC is present, re-connect 1J1, 2J1 and 3J1 connectors, one at a time If ± 12 VDC disappears when 1J1, 2J1 and 3J1 connectors are reapplied, a short may exist on one of the servo modules, respectively
		Disconnect J2 and measure Vbus voltage between "Red" wire (+) and "Blue" wire (-). If voltage is higher than specifications, re-check input wiring on the 19" rack
		Monitor bus inhibit testpoint with respect to signal common and turn shunt adjust pot full CW. If zero volts is read, and Vbus is within specifications, replace supervisory module. (Normal reading should be $+12$ VDC.)
		NOTE: The value of Vbus can easily be determined by removing connector J2 of the supervisory module and measuring the DC voltage between the "Red" wire (+) and the "Blue" wire (-)
	± 12 VDC control voltages not in ranges specified in figure 2-2	Monitor $+12$ VDC and -12 VDC testpoint with respect to signal common. If voltages are below ranges specified, disconnect 1J1, 2J1, 3J1

CHAPTER 4

<u>SYMPTOM</u>	<u>POSSIBLE CAUSE</u>	<u>SOLUTION</u>
		J4 and J5 connectors to supervisory module. If voltages are still low, replace supervisory module. If voltages assume the normal ± 12 volt levels, check for shorts on the terminal board or the control stage of the servo module
		For a rough check on shorts to the control stage of the servo modules, use an analog VOM set at X100 scale
		Place (+) lead on +12 VDC and (-) lead on Sig. Com. testpoints of servo module. Reading should be approximately 2Kohms
		Place (+) lead on Sig. Com. and (-) lead on -12 VDC testpoints of servo module. Reading should be approximately 5Kohms.
Shunt LED energizes after power up	Shunt adjust pot set to energize at too low a Vbus level	Turn the shunt pot CW to increase shunt range (NOTE: THE SHUNT ADJUST POT IS FACTORY SET FOR SHUNT REGULATION AT A VBUS LEVEL OF 185 VDC FOR THE 160V SERIES, 115 VDC FOR THE 100QV SERIES AND 100 VDC FOR THE 80QV SERIES SERVO MODULE)
		Turning this pot CW allows the circuit to activate at a higher level of Vbus

CHAPTER 4

<u>SYMPTOM</u>	<u>POSSIBLE CAUSE</u>	<u>SOLUTION</u>
		<p>If after turning this pot full CW, the shunt LED still remains energized, replace the supervisory module. (Remember, if the shunt fuse F1 opens, the fault light on the supervisory module will energize when the shunt circuit tries to energize)</p>
Shunt resistor fuse, F1, opens periodically during motor regeneration	Shunt regulator regenerative capacity is being exceeded	Reduce regeneration cycle (do not increase current rating of fuse F1)

CHAPTER 5

SECTION 5-1 SERVICE AND REPAIR

General repair of equipment consists entirely of solutions listed in sections 4-1, 4-2 and 4-3 on Troubleshooting, or the removal and replacement of a servo module or supervisory module, should the need arise. IF UNDER WARRANTY, REPAIR OF DEFECTIVE ELECTRICAL COMPONENTS OF THE BASE PLATE SHOULD NOT BE ATTEMPTED, SINCE TO DO SO WOULD VOID THE ENTIRE WARRANTY.

If necessary, any on-site service should be performed by an experienced electronic technician, preferably trained by Aerotech, Inc. It is recommended that the user NOT attempt repair of the servo modules or supervisory module, (except for those items associated with changing fuses) whether these units are under warranty or not.

SECTION 5-2 SHIPMENT

The procedure for shipping equipment back to Aerotech for repair is shown below. This procedure pertains to warranty as well as non-warranty repairs of equipment.

1. Before shipping any equipment back to Aerotech, Inc., the person making the return should call ahead for a "Return Authorization Number".
2. The equipment being returned must be encased in a proper cushioning material and enclosed in a cardboard box.
3. Equipment should be sent to:

Aerotech, Inc.
101 Zeta Drive
Pittsburgh, PA 15238
Phone: (412) 963-7470
c/o Customer Service

WARNING: DAMAGE DUE TO IMPROPER PACKAGING VOIDS WARRANTY.

CHAPTER 5

SECTION 5-3 PARTS LIST (19" RACK)

For the 160V, 100QV and 80QV SERIES 19" Rack:

<u>DESCRIPTION</u>	<u>PART NUMBER</u>	<u>MANUFACTURER</u>
Fuses F1, F2, F3	FNW-30	Bussman
Ribbon Cables: (set of three) 1, 2, 3J1 to J2, J2, J2 (supervisory module to servo modules)	630D1262 Assy. F	Aerotech
Bridge Rectifier (BR 1)	ECD903	Aerotech
Shunt Resistor (R1)	ECR119	Aerotech
Filter Capacitor (C1, C2)	ECC115	Aerotech

SECTION 5-4 PARTS LIST (SERVO MODULES)

<u>DESCRIPTION</u>	<u>PART NUMBER</u>	<u>MANUFACTURER</u>
Fuse (F1) for servo module:		
160V	MDA-15	Bussman
100QV	MDA-10	"
80QV	MDA-10	"
Servo modules:		
160V	EFA441	Aerotech
100QV	EFA443	"
80QV	EFA446	"
Personality modules (see figure 2-11):		
RCN1-1	630B1270-1	Aerotech
RCN1-2	630B1270-2	"
RCN1-3	630B1270-3	"
RCN1-4 *	630B1270-4	"
RCN2-1	630B1271-1	Aerotech
RCN2-2	630B1271-2	"
RCN2-3	630B1271-3	"
RCN2-4 *	630B1271-4	"

* Shipped only with "header" and "cover";
1/4 watt resistors and capacitors not included.

CHAPTER 5

SECTION 5-5 PARTS LIST (SUPERVISORY MODULE)

<u>DESCRIPTION</u>	<u>PART NUMBER</u>	<u>MANUFACTURER</u>
Fuse F1	313003	Littlefuse
Fuse F2	313001	Littlefuse
Supervisory module (for use with the 160V, 100QV or 80QV servo module)	EFA908	Aerotech

INDEX

A

Adjustment, 3-13, 3-14
Adjustments, 3-14
Analog control signals, 2-3

B

Balance pot, 2-13
Bus inhibit testpoint, 2-25

C

Captive screws, 3-1
Compensation, 2-2
Component description
 rack (19"), 2-29
 servo modules, 2-9, 2-12, 2-13, 2-14, 2-15
 supervisory module, 2-25
 supervisory modules, 2-22, 2-26, 2-27, 2-28
Connections, 3-5
Connector J2, 2-25
Connectors 1J1
 2J1 and 3J1, 2-26
Connectors 1J3
 2J3 and 3J3, 2-26
Connectors J4 and J5, 2-26
Control transformer, 2-27
Control voltage rectifier, 2-27
Current command testpoint, 2-13
Current feedback clamp circuits, 2-2
Current feedback testpoint, 2-13
Current limit circuit, 2-2
Current limit pot, 2-13
Current monitor, 2-37
Current monitor programming jumper, 2-15

D

DC bus input connector (J1), 2-15
DC motor, 2-1
Dynamic current limit circuit, 2-3, 2-17
Dynamic current limit pot, 2-14

E

Electrical specifications, 2-5, 2-6, 2-7, 2-8

F

Fault, 2-26, 2-38
Fault driver output circuit, 2-28
Fault LED, 2-25
Fault programming jumper, 2-26
Fault time-out circuit, 2-28
Filter circuit, 2-27
Fuse F1, 2-25
Fuse F2, 2-26

G

Gain, 2-2
Gain pot, 2-13, 3-19
General description, 2-1, 2-2

H

High DC bus detect circuit, 2-27

I

I limit, 2-37, 2-38
Input, 2-37
Input (speed) command testpoint, 2-13
Input command pot, 2-14
Input pot, 3-14
Input power, 3-6, 3-7, 3-8, 3-9, 3-10, 3-11
Input/output logic, 2-3
Installation and start-up, 3-1, 3-5
Introduction, 1-1

L

Low level detect circuit, 2-27

M

Module identification, 2-4
Motor current, 3-16
Motor load fuse (F1), 2-14
Motor output connector (J1), 2-15
Motor power connections, 3-12
Motor speed, 3-16
Mounting holes, 3-3, 3-4

N

Nand logic circuits, 2-28
Negative feedback, 2-2

O

Operator's manual, 1-1

P

Parts list, 5-2, 5-3, 5-4
Personality module
 RCN1, 2-15
 RCN2, 2-15
Personality modules specifications, 2-19, 2-20, 2-21
Position loop, 3-13, 3-14
Position loop stability, 3-14
Pots, 3-13
Pre-amplifier circuit, 2-18

R

Regulator circuits, 2-27
Repair, 5-1
Reset button, 2-12
Ripple current, 3-19, 3-20, 3-21
RMS current limit circuit, 2-3, 2-16

RMS limit LED, 2-12

S

Service, 5-1

Servo module parts list, 5-3

Shipment, 5-1

Shunt adjust pot, 2-25

Shunt LED, 2-25

Shunt regulator, 2-3

Shunt regulator circuit, 2-27

Shut down, 2-37

Signal common, 2-12, 2-37

Signal common testpoint, 2-25

Speed error, 2-2

Supervisory module, 2-3

Supervisory module control connection (J2), 2-14

Supervisory module parts list, 5-4

T

Tach, 2-37

Tach feedback pot, 2-14

Tach feedback signal, 2-3

Tach feedback testpoint, 2-13

Tach pot, 3-14

Tachometer, 2-1

Terminal board, 2-33

Transconductance, 2-2

Trip LED, 2-12

Troubleshooting, 4-1, 4-2, 4-3, 4-4, 4-5, 4-6, 4-7, 4-8

V

VDC supply, 2-12

VDC testpoint, 2-25

Velocity loop, 2-1