

# **AGS15000HL Series Stage**

## **User's Manual**

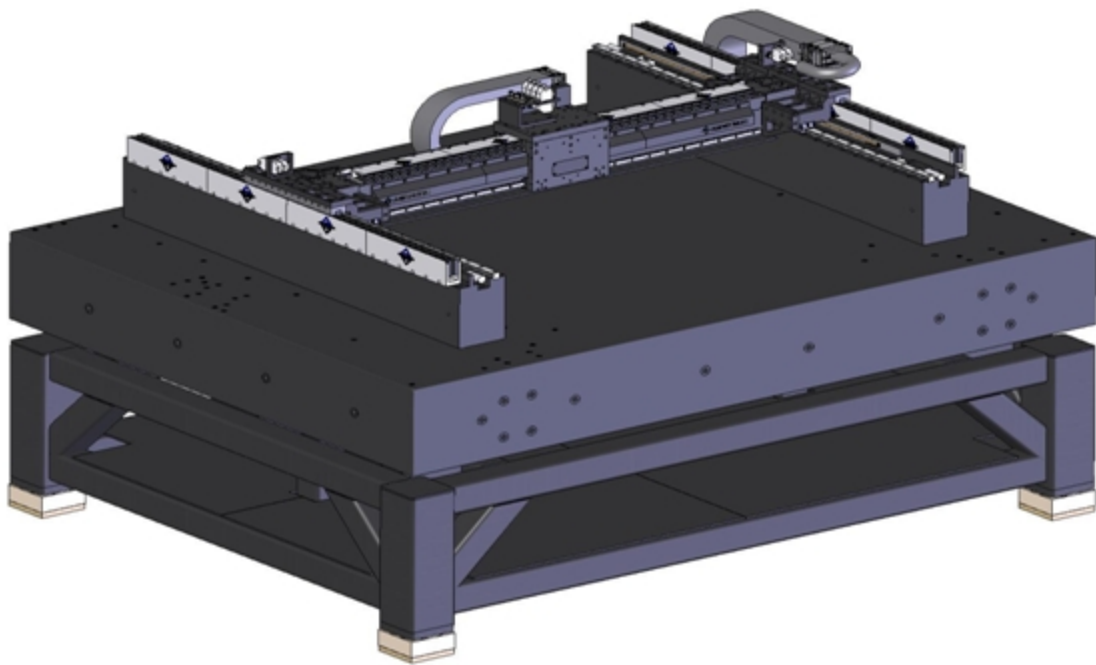

Dedicated to the Science of Motion  
Aerotech, Inc.  
101 Zeta Drive,  
Pittsburgh, PA, 15238  
Phone: 412-963-7470  
Fax: 412-963-7459  
[www.aerotech.com](http://www.aerotech.com)



## Product Registration

Register online at: <http://www.aerotech.com/prodreg.cfm>

## Technical Support

### United States Headquarters:

Phone: (412) 967-6440

Fax: (412) 967-6870

Email: [service@aerotech.com](mailto:service@aerotech.com)

### United Kingdom:

Phone: +44 118 940 9400

Fax: +44 118 940 9401

Email: [service@aerotech.co.uk](mailto:service@aerotech.co.uk)

### Germany:

Phone: +49 911 967 9370

Fax: +49 911 967 93720

Email: [service@aerotechgmbh.de](mailto:service@aerotechgmbh.de)

### Japan:

Phone: +81(0)47-489-1741 (Sales)

Phone: +81(0)47-489-1742 (Service)

Fax: +81(0)47-489-1743

Email: [service@aerotechkk.com.jp](mailto:service@aerotechkk.com.jp)

### China:

Phone: +852-3793-3488

Email: [saleschina@aerotech.com](mailto:saleschina@aerotech.com)

## Revision History

Revision 1.01.00 February 21, 2011

Revision 1.00.00 October 31, 2008

## Table of Contents

Table of Contents.....	iii
List of Figures.....	v
List of Tables.....	vii
<b>Chapter 1: Overview.....</b>	<b>1</b>
1.1. Standard Features.....	2
1.1.1. Linear Motor / Linear Encoder.....	2
1.1.2. Rugged Design.....	2
1.1.3. CMS Options.....	2
1.1.4. Turnkey Operation.....	2
1.2. Optional Features.....	3
1.2.1. Additional Axes.....	3
1.2.2. Cleanroom Compatability.....	3
1.2.3. Electronics / Controller.....	3
1.3. Model Numbers.....	4
1.4. Safety Procedures and Warnings.....	6
1.5. EC Declaration of Incorporation.....	8
<b>Chapter 2: Installation.....</b>	<b>9</b>
2.1. Unpacking and Handling the Stage.....	9
2.2. Mounting the System to a Machine Base.....	10
2.3. Attaching the Payload to the Stage.....	12
2.4. Electrical Installation.....	12
2.5. Air Requirements.....	12
<b>Chapter 3: Operating Specifications.....</b>	<b>13</b>
3.1. Environmental Specifications.....	13
3.2. Load Capability.....	13
3.3. Basic Specifications.....	14
3.4. Overtravel Safety.....	16
<b>Chapter 4: Maintenance.....</b>	<b>17</b>
4.1. Service and Inspection Schedule.....	17
4.2. Cleaning and Lubrication.....	17
4.3. Linear Lubrication and Cleaning Procedure.....	18
4.4. Linear Encoder Cleaning and Maintenance Procedure.....	19
4.5. System Calibration Procedure.....	20
<b>Appendix A: Warranty and Field Service.....</b>	<b>21</b>
<b>Appendix B: Technical Changes.....</b>	<b>23</b>
<b>Appendix C: Payload and Performance Plots.....</b>	<b>25</b>
<b>Index.....</b>	<b>27</b>
<b>Reader's Comments.....</b>	<b>29</b>



**List of Figures**

Figure 2-1: Compliant Mounting, With and Without Mounting Bolt.....	10
Figure 4-1: Location of Grease Nipples (approximate).....	18
Figure 4-2: Removing Upper Axis Encoder Cover.....	19



**List of Tables**

Table 1-1: Model Numbering System .....	4
Table 3-1: Environmental Specifications.....	13
Table 3-2: AGS15000HL Series Specifications.....	14
Table 3-3: AGS15000HL Motor Specifications.....	15
Table B-1: Current Changes (1.01.00).....	23
Table B-2: Archived Changes.....	24





## Chapter 1: Overview

The AGS15000HL series of Cartesian gantry systems is designed for ultra-precision contouring capabilities, providing outstanding performance and versatility in a wide range of automation platforms. To ensure high contouring accuracy, the bridge's center of gravity is kept in line with the lower axis bearings and forcers to minimize pitch and roll errors at the work point.

AGS15000HL systems can be found in production plants around the world, in applications including precision micromachining, stencil cutting, fuel cell manufacturing, flat sheet processing, high-speed pick-and-place, automated assembly, vision inspection, dispensing stations, and high-accuracy inspection.

This manual describes Aerotech's AGS15000HL series positioning gantry. This chapter introduces standard and optional features of the AGS15000HL, and gives general safety precautions.

**NOTE:** This manual should be read in its entirety before operating the AGS15000HL system.

## 1.1. Standard Features

### 1.1.1. Linear Motor / Linear Encoder

Aerotech's high-performance brushless linear servomotors drive the AGS15000HL to speeds up to 3 m/s and accelerations up to 5 g. Dual linear motors and encoders are included on the lower axis for the highest level of performance and precision. The rugged noncontact optical linear encoders offer resolutions to 1 nm when coupled with Aerotech's encoder multiplier. Optimized to account for thermal expansion, the design ensures high accuracy under all operating conditions.

### 1.1.2. Rugged Design

The linear motor is a noncontact device, resulting in no backlash, wear, or maintenance. The bearings are preloaded linear motion guides with wiper seals and grease fittings, and are mounted to provide optimized stiffness and load distribution.

### 1.1.3. CMS Options

Extensive R&D has resulted in an optimized cable management system (CMS) that has been field proven as the industry's most reliable design. Large bend radii and high-flex cables ensure that the AGS15000HL provides millions of cycles of maintenance-free operation. In the unlikely event of a component failure, a modular design ensures that part replacement is fast and easy. The CMS on the AGS15000HL has also been designed to provide smooth and quiet operation.

All customer cabling and pneumatics can be routed through the system cable management. Connectors are provided at the workpiece and at the opposite end of the cable management, greatly simplifying final machine integration.

### 1.1.4. Turnkey Operation

Aerotech's years of experience manufacturing precision positioning and control systems can be leveraged by acquiring a turnkey system. Typical options include Z-theta mechanisms, risers to accommodate automated parts handling equipment, and machine bases that are designed to accommodate the entire controls and electronics subsystems.

Aerotech manufactures a wide range of high-performance amplifiers and advanced motion controllers that are optimized for high-performance automation applications.

## 1.2. Optional Features

### 1.2.1. Additional Axes

Additional motion axes can be integrated onto the 2-axis AGS15000HL system. Typically, one or two additional axes (linear or rotary) are integrated onto the carriage of the cross axes. All system alignments and metrology are qualified with these additional axes integrated onto the system. Separate Hardware Manuals will be provided for additional axes integrated onto the AGS15000HL system.

### 1.2.2. Cleanroom Compatability

The AGS15000HL can be configured for up to Class 10 cleanroom operation. Standard features for Class 10 cleanroom operation are:

- Stainless Hardware
- Custom cable management (depending on the level of cleanroom, a trackless cable carrier may be utilized)
- Cleanroom grease – refer to section 4.2 for grease specification.

### 1.2.3. Electronics / Controller

The AGS15000HL is typically part of a complete Aerotech motion control system, which is adjusted at the factory for optimum performance. Setup usually involves connecting a stage to the appropriate drives with the cables provided. Refer to your electrical documentation package for further information.

### 1.3. Model Numbers

The stage model number indicates the optional features on a particular stage. To determine the options on a particular stage, refer to the table below.

**Example:** AGS15-500-500-HL-10X2-10-LT50X5-LT50X5-GR

**Table 1-1: Model Numbering System**

<b>AGS15000 Series Linear Motor Gantry</b>	
AGS15500-500	500 mm x 500 mm (20 in x 20 in) Cartesian gantry with linear motor, linear encoder, and limits
AGS15750-750	750 mm x 750 mm (30 in x 30 in) Cartesian gantry with linear motor, linear encoder, and limits
AGS151000-1000	1000 mm x 1000 mm (40 in x 40 in) Cartesian gantry with linear motor, linear encoder, and limits
AGSxxxx-yyyy	Other travels available; please consult factory
<b>Loading</b>	
-HL	High loading
<b>Motor</b>	
-10	Brushless linear motor – BLM-264-A (upper Y-axis only)
-10X2	Dual brushless linear motor – dual BLM-386-A (lower X-axis only)
-10HX2	Dual brushless linear motor – dual BLMH-382-A (lower X-axis only)
<b>Limits</b>	
-NC	Normally closed end of travel limit switches (STANDARD)
-NO	Normally open end of travel limit switches
<b>Standard Linear Encoders</b>	
-LT50AS	Dual linear encoder for lower axis; amplified sine output; linear encoder for upper axis
-LT50X50	Dual linear encoder for lower axis; 0.1 micron line driver output; linear encoder for upper axis
-LT75AS	Dual linear encoder for lower axis; amplified sine output; linear encoder for upper axis
-LT75X50	Dual linear encoder for lower axis; 0.1 micron line driver output; linear encoder for upper axis
-LT100AS	Dual linear encoder for lower axis; amplified sine output; linear encoder for upper axis
-LT100X50	Dual linear encoder for lower axis; 0.1 micron line driver output; linear encoder for upper axis
<b>Base Plate</b>	
-GR500-500	Granite baseplate for AGS15500-500
-GR750-750	Granite baseplate for AGS15750-750
-GR1000-1000	Granite baseplate for AGS151000-1000
-GRR500-500	Granite baseplate for AGS15500-500 with 150 mm (6 in) risers
-GRR750-750	Granite baseplate for AGS15750-750 with 150 mm (6 in) risers
-GRR1000-1000	Granite baseplate for AGS151000-1000 with 150 mm (6 in) risers

**Table 1-1: Model Numbering System (continued)**

<b>Accessories (to be ordered as separate line item)</b>	
Z100	100 mm (4 in) travel z-stage
Z150	150 mm (6 in) travel z-stage
THETA	360° travel theta axis
MB500-500	Steel weldment machine base for AGS15500-500
MB750-750	Steel weldment machine base for AGS15750-750
MB1000-1000	Steel weldment machine base for AGS1000-10000

## 1.4. Safety Procedures and Warnings

The following statements apply throughout this manual. Failure to observe these precautions could result in serious injury to those performing the procedures and damage to the equipment.

This manual and any additional instructions included with the stage should be retained for the lifetime of the stage.



DANGER

To minimize the possibility of electrical shock and bodily injury or death, disconnect all electrical power prior to making any electrical connections.



DANGER

To minimize the possibility of electrical shock and bodily injury or death when any electrical circuit is in use, ensure that no person comes in contact with the circuitry when the stage is connected to a power source.



DANGER

To minimize the possibility of bodily injury or death, disconnect all electrical power prior to making any mechanical adjustments.



DANGER

Moving parts of the stage can cause crushing or shearing injuries. All personnel must remain clear of any moving parts.



WARNING

Improper use of the stage can cause damage, shock, injury, or death. Read and understand this manual before operating the stage.



WARNING

If the stage is used in a manner not specified by the manufacturer, the protection provided by the stage can be impaired.



WARNING

Stage cables can pose a tripping hazard. Securely mount and position all stage cables to avoid potential hazards.



WARNING

Do not expose the stage to environments or conditions outside the specified range of operating environments. Operation in conditions other than those specified can cause damage to the equipment.



WARNING

The stage must be mounted securely. Improper mounting can result in injury and damage to the equipment.



WARNING

Use care when moving the stage. Manually lifting or transporting stages can result in injury.



WARNING

Only trained personnel should operate, inspect, and maintain the stage.



WARNING

This stage is intended for light industrial manufacturing or laboratory use. Use of the stage for unintended applications can result in injury and damage to the equipment.



WARNING

Before using this stage, perform an operator risk assessment to determine the needed safety requirements.

## 1.5. EC Declaration of Incorporation

**Manufacturer:** Aerotech, Inc.  
101 Zeta Drive  
Pittsburgh, PA 15238  
USA



**herewith declares that the product:**

Aerotech, Inc. AGS15000HL Stage

**is intended to be incorporated into machinery to constitute machinery covered by the Directive 2006/42/EC as amended;**

**does therefore not in every respect comply with the provisions of this directive;**

**and that the following harmonized European standards have been applied:**

EN ISO 12100-1,-2:2003+A1:2009

*Safety of machinery - Basic concepts, general principles for design*

ISO 14121-1:2007

*Safety of machinery - Risk assessment - Par 1: Principles*

EN 60204-1:2005

*Safety of machinery - Electrical equipment of machines - Part 1: General requirements*

**and further more declares that**

***it is not allowed to put the equipment into service until the machinery into which it is to be incorporated or of which it is to be a component has been found and declared to be in conformity with the provisions of the Directive 2006/42/EC and with national implementing legislation, i.e. as a whole, including the equipment referred to in this Declaration.***

**This is to certify that the aforementioned product is in accordance with the applicable requirements of the following Directive(s):**

2011/65/EU

RoHS 2 Directive

**Authorized Representative:** Manfred Besold  
**Address:** AEROTECH GmbH  
Süd-West-Park 90  
D-90449 Nürnberg

**Name:**

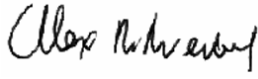
Alex Weibel /   
Engineer Verifying Compliance

**Position:**

**Location:**

Pittsburgh, PA

**Date:**

February 21, 2011



## Chapter 2: Installation

This chapter describes the installation procedure for the AGS15000HL series gantry, including handling the stage properly, preparing the mounting surface to accept the stage, securing the stage to the mounting surface, attaching the payload, and making the electrical connections.



Installation must follow the instructions in this chapter. Failure to follow these instructions could result in injury and damage to the equipment.

### 2.1. Unpacking and Handling the Stage

Carefully remove the system from the protective shipping container. The AGS15000HL system is supplied on a granite base plate. An additional system base (typically steel) may also be included with the system. A fork truck is recommended as a means of moving the system. If there is no system base, or if the system must be moved independently of its base for any reason, always use a piece of wood or similar material between the forks and the granite. Use compressed nitrogen or clean, dry air to remove any dust or debris that has collected during shipping. *If any damage has occurred during shipping, report it immediately.*

Before operating the stage, it is important to let the stage stabilize at room temperature for at least 12 hours. Allowing the stage to stabilize to room temperature will help to ensure that all of the alignments, preloads, and tolerances are the same as they were when tested at Aerotech.

Each stage has a label listing the system part number and serial number. These numbers contain information necessary for maintaining or updating system hardware and software. Locate this label and record the information for later reference.



Improper stage handling could adversely affect the stage's performance. Use care when moving the system. Manually lifting or transporting stages can result in injury.

## 2.2. Mounting the System to a Machine Base

If the system was shipped with a machine base, remove the red shipping brackets before using the system. Level the base plate by adjusting the leveling feet on the machine base. If the system is to be placed on a base after delivery, it is important to do so properly for optimal performance. It should be supported in three or four places unless otherwise specified during the system approval process. A compliant mounting scheme (shown in Figure 2-1) is recommended for most cases. Consult with Aerotech to ensure that this method is acceptable for a specific application.

For compliant mounting, the machine base mounting surfaces should be coplanar within 0.25 mm (.010 in). A compliant material at least 6 mm (0.25 in) thick should be inserted between the base and granite base plate (contact Aerotech for recommended materials). Mounting screws may be used if extra security is desired between the base plate and machine base. If they are used, compliant washers should be placed under the screw heads. Tighten screws only  $\frac{1}{4}$  to  $\frac{1}{2}$  turn past “finger tight”, using a generous amount of a thread-locking compound to keep the screws in place. This compliant mounting method allows for small height differences between mounting surfaces, thermal expansion mismatch due to different base plate and machine base materials, and also provides vibration isolation between the floor and the gantry system. If a compliantly mounted system is to be transported, the base plate should be rigidly attached to the machine base during shipping.

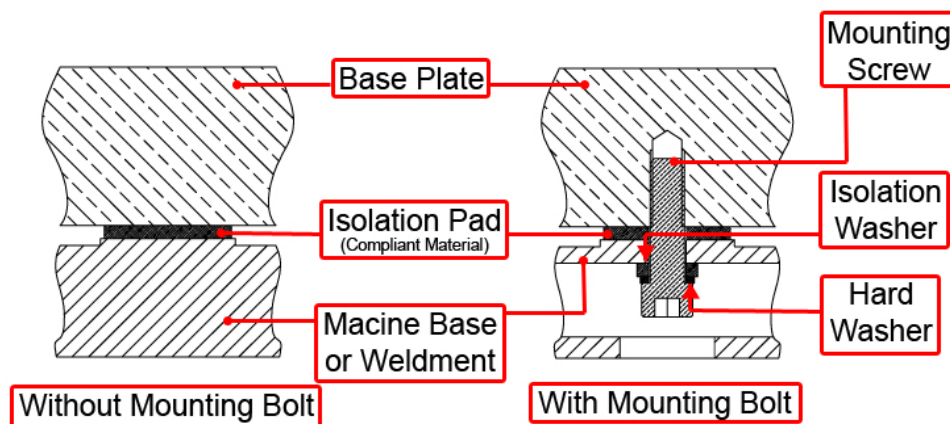

Figure 2-1: Compliant Mounting, With and Without Mounting Bolt

When a system requires extremely high accuracy or ground vibrations are especially prominent, a more complex isolation system may be necessary. Air isolation may be used but is only recommended for systems with relatively low dynamics. An active isolation system may achieve the same results and can be used for systems with higher dynamics. Aerotech can supply system properties that may help in sizing these specialized systems.

If relative motion between the gantry system and machine base is absolutely unacceptable for a given application, hard mounting may be necessary. Mounting tolerances, thermal mismatch, and environmental vibrations must be considered when designing a hard mounting scheme. If these issues are not addressed properly, the base plate may become distorted and affect system performance. Contact Aerotech to determine whether system specifications can be guaranteed with a specific mounting method.



The stage must be mounted securely. Improper mounting can result in injury and damage to the equipment.

### 2.3. Attaching the Payload to the Stage

To prevent damage to the stage or parts, test the operation of the stage before any fixturing or customer equipment is integrated onto the system. Proceed with the electrical installation and test the motion control system.

After testing, a payload may be attached to the upper axis carriage face. The payload must have a mounting surface that is flat within .013 mm (.0005 in) to prevent distortion of the carriage. If a payload is to be attached at any other point on the gantry, contact Aerotech for flatness requirements.

### 2.4. Electrical Installation

Aerotech motion control systems are adjusted at the factory for optimum performance. The AGS15000HL stage is typically part of a complete Aerotech motion control system; setup involves connecting a stage to the appropriate drives with the cables provided.

Connect the provided cables to the motor and feedback connectors on the stage. Labels on the drive indicate the appropriate connections. Refer to your drive manuals and documentation for additional installation and operation information. In some cases, if the system is uniquely configured, a drawing showing system interconnects is supplied.



WARNING

Never connect or disconnect any electrical component or connecting cable while power is applied, or serious damage may result.



WARNING

The stage's protective ground is located on the motor power connector. This ground must be connected to a ground connection (the cables provided by Aerotech will create this connection).

### 2.5. Air Requirements

It is recommended that air cooling be utilized for the linear motors if duty cycle, speeds, and/or accelerations are high. Consult an Aerotech applications engineer to determine if air cooling is required or recommended for a specific application. The air requirements are dependent on the system specifications (cleanliness, etc).

**NOTE:** For Cleanroom applications, clean, dry nitrogen is recommended since the motor cooling exhausts into the work area. Recommended specifications for Nitrogen are 99.99% pure and filtered to 0.25 microns.

**NOTE:** When operating the AGS15000HL it is recommended that 20 psig air be available **at the motor inlet** for adequate cooling.

## Chapter 3: Operating Specifications

The surrounding environment and operating conditions can affect the performance and service life of the stage. This chapter provides information on ideal environmental and operating conditions. Also included are instructions for estimating load and torque required to turn the ballscrew given various loadings.

### 3.1. Environmental Specifications

The environmental specifications for the AGS15000HL are listed in the following table.

**Table 3-1: Environmental Specifications**

<b>Ambient Temperature</b>	Operating: 16° to 25° C (61° to 77° F) The optimal operating temperature is 20° C $\pm$ 2° C (68° F $\pm$ 4° F). If at any time the operating temperature deviates from 20° C degradation in performance could occur. Contact Aerotech for information regarding your specific application and environment.
	Storage: 0° to 40° C (32° to 104° F) in original shipping packaging
<b>Humidity</b>	Operating: 40 percent to 60 percent RH The optimal operating humidity is 50 percent RH.
	Storage: 30 percent to 60 percent RH, non-condensing in original packaging
<b>Altitude</b>	Operating: 0 to 2,000 m (0 to 6,562 ft) above sea level Contact Aerotech if your specific application involves use above 2,000 m or below sea level.
<b>Vibration</b>	Use the system in a low vibration environment. Excessive floor or acoustical vibration can affect stage and system performance. Contact Aerotech for information regarding your specific application.
<b>Dust Exposure</b>	The AGS15000HL stages are not suited for dusty or wet environments. This equates to an ingress protection rating of IP00.
<b>Use</b>	Indoor use only



Do not expose the stage to environments or conditions outside the specified range of operating environments. Operation in conditions other than those specified can cause damage to the equipment.

### 3.2. Load Capability

The AGS15000HL is designed for a multitude of applications. The maximum load on the upper axis of the system is 40 kg. This weight of all additional axes integrated onto the system as well as all customer fixturing and/or test equipment contributes to this load. The load capacity is reduced if the load must be cantilevered away from the face of the upper axis. Contact Aerotech to determine acceptable loading limits for offset payloads.

The performance of the AGS15000HL will be affected by large payloads. See Appendix C: Payload and Performance Plots to see how the accelerations of each axis are affected by payload.

**NOTE:** Contact Aerotech directly if load requirements exceed those agreed upon during system approval.

### 3.3. Basic Specifications

Basic specifications are given in Table 3-2 and motor specifications are given in Table 3-3.

**Table 3-2: AGS15000HL Series Specifications**

Basic Model		AGS15000-500-500	AGS15000-750-750	AGS15000-1000-1000	AGS15000-1250-1250
Total Travel		500 mm x 50 mm (20 in x 20 in)	750 mm x 750 mm (30 in x 30 in)	1000 mm x 1000 mm (40 in x 40 in)	1250 mm x 1250 mm (50 in x 50 in)
Drive System <sup>(1)</sup>	Lower Axis	Linear Brushless Servomotor — Dual BLM-386-A or Dual BLMH-382-A			
	Upper Axis	Linear Brushless Servomotor — BLM-264-A			
Bus Voltage		Up to 340 VDC			
Feedback		Noncontact Linear Encoder			
Resolution <sup>(2)</sup>		0.001 $\mu\text{m}$ - 1.0 $\mu\text{m}$ (0.04 $\mu\text{in}$ - 40 $\mu\text{in}$ )			
Maximum Travel Speed <sup>(3)</sup>		3 m/s (120 in/s)			
Maximum Linear Acceleration		5 g (50 m/s <sup>2</sup> ) (no-load)			
Maximum Load <sup>(4)</sup>		40.0 kg (88.2 lb)			
Accuracy <sup>(5,6)</sup>		$\pm 1.5 \mu\text{m}$ ( $\pm 60 \mu\text{in}$ )	$\pm 2.0 \mu\text{m}$ ( $\pm 80 \mu\text{in}$ )	$\pm 2.5 \mu\text{m}$ ( $\pm 100 \mu\text{in}$ )	$\pm 3.0 \mu\text{m}$ ( $\pm 120 \mu\text{in}$ )
Repeatability		$\pm 0.5 \mu\text{m}$ ( $\pm 20 \mu\text{in}$ )	$\pm 0.75 \mu\text{m}$ ( $\pm 30 \mu\text{in}$ )	$\pm 1.0 \mu\text{m}$ ( $\pm 40 \mu\text{in}$ )	$\pm 1.25 \mu\text{m}$ ( $\pm 50 \mu\text{in}$ )
Orthogonality		5 arc sec			
Moving Mass	Lower Axis	62.0 kg	72.3 kg	82.5 kg	92.7 kg
	Upper Axis	7.2 kg			
Material		Aluminum			
Finish	Stage	Black Anodize; ESD Optional			
	Carriage	Hard Coating; ESD Optional			
<p>(1) Air cooling options available.</p> <p>(2) With encoder multiplier.</p> <p>(3) Maximum speed based on stage capability; maximum application velocity may be limited by system data rate and system resolution.</p> <p>(4) Maximum load based on bearing capability; maximum application load may be limited by acceleration and dynamic requirements.</p> <p>(5) Measured at center of travel, single axis under static conditions.</p> <p>(6) Available with Aerotech controllers with HALAR.</p>					

Table 3-3: AGS15000HL Motor Specifications

Model		BLM-264	BLM-386	BLMH-382
Winding Designation		-A	-A	-A
<b>Performance Specifications (1,5)</b>				
Continuous Force, 20 psi, 1.4 bar (2)	N	233.8	308.2	548.8
	lb	52.6	69.3	123.4
Continuous Force, No Cooling, (2)	N	152.9	199.4	357.9
	lb	34.4	44.8	80.5
Peak Force (3)	N	935.4	1232.8	2195.0
	lb	210.3	277.2	493.5
<b>Electrical Specifications (5)</b>				
BEMF Constant (line to line, max)	V / m / sec	34.46	52.10	45.71
	V / in / sec	0.88	1.32	1.16
Continuous Current, 20 psi, 1.4 bar (2)	A, pk	7.80	6.80	13.80
	A, rms	5.52	4.81	9.76
Continuous Current, No Cooling (2)	A, pk	5.10	4.40	9.00
	A, rms	3.61	3.11	6.36
Peak Current, Stall (3)	A, pk	31.20	27.20	55.20
	A, rms	22.06	19.23	39.03
Force Constant, Sinusoidal Drive (4,8)	N / A, pk	29.98	45.33	39.77
	lb / A, pk	6.74	10.19	8.94
	N / A, rms	42.40	64.10	56.24
	lb / A, rms	9.53	14.41	12.64
Motor Constant (2,4)	N / $\sqrt{W}$	12.71	15.64	23.19
	lb / $\sqrt{W}$	2.86	3.52	5.21
Resistance, 25 °C (line to line)	Ohms	5.3	8.0	2.8
Inductance (line to line)	mH	4.20	6.20	1.80
Thermal Resistance, 20 psi, 1.4 bar	°C / W	0.30	0.26	0.18
Thermal Resistance, No Cooling	°C / W	0.69	0.61	0.42
Maximum Bus Voltage	VDC	340	340	340
<p>(1) Performance is dependent upon heat sink configuration, system cooling conditions, and ambient temperature</p> <p>(2) Values shown @ 100 °C rise above a 25 °C ambient temperature, with motor mounted to the specified aluminum heat sink</p> <p>(3) Peak force assumes correct rms current, consult Aerotech</p> <p>(4) Force Constant and Motor Constant specified at stall</p> <p>(5) All performance and electrical specifications +/- 10%</p> <p>(6) Maximum winding temperature is 125 °C</p> <p>(7) Ambient operating temperature range: 0 °C - 25 °C, consult Aerotech for performance in elevated ambient temperatures</p> <p>(8) All Aerotech amplifiers are rated Apk; use torque constant in N-m / Apk when sizing</p>				

### 3.4. Overtravel Safety

Each AGS15000HL is designed to operate at certain speeds and accelerations that are unique to that system. The gantry is designed to prevent damage to itself and injury to the operator when used as specified upon system approval. If any combination of payloads, speeds, and accelerations are to be used other than those originally approved, contact Aerotech. Do not attempt to modify the system in any way that would affect overtravels or hard stops.



WARNING

Attaching larger payloads or using higher speeds and/or accelerations than those specified during system approval may cause damage to the system or injury to the operator.



WARNING

Modifying the AGS15000HL in any way that affects overtravels or hard stops may cause serious system damage or injury to the operator and will void the stage warranty.



## Chapter 4: Maintenance

This chapter will cover information about component replacement, intervals between lubrications, detail the lubrication and inspection process, and cover which lubricants are recommended for use.



To minimize the possibility of bodily injury, confirm that all electrical power is disconnected prior to making any mechanical adjustments.

The AGS15000HL linear bearing area must be kept free of foreign matter and moisture; otherwise the performance and life expectancy of the stage will be reduced.

### 4.1. Service and Inspection Schedule

Lubricant inspection and replenishment in AGS15000HL series stages depends on conditions such as duty cycle, speed, and the environment. An inspection interval of once every few months is recommended until a trend develops for the application. Longer or shorter intervals may be required to maintain the film of lubricant on the bearing surfaces. In general, it is recommended that stages operating in a clean environment be lubricated annually. For stages operating under conditions involving excessive debris, lubrication every 3-6 months is recommended. If the system is being operated at a high duty cycle, it is recommended that the bearings be lubricated after 10,000 km of operation.

### 4.2. Cleaning and Lubrication

The bearings of the AGS15000HL are generally greased with BR2-Plus grease (supplier is Dow Corning). <http://www.dowcorning.com/applications/search/default.aspx?R=3178EN>. Other greases may be used for cleanroom or other special applications. Contact Aerotech for confirmation on what grease is used in a particular system.

There is one grease nipple per bearing block, for a total of 8 grease points (See Figure 4-1). The grease nipples are type PB1021B for the upper axis and type B-M6F for the lower (supplied by THK). A type N grease gun fitting should be used for the upper axis bearings and type B for the lower axis bearings (also supplied by THK). <http://www.thk.com>.

If a solvent is necessary for cleaning the stage, it is recommended that isopropyl rubbing alcohol be used. Harsher solvents, such as acetone, may damage the plastic and rubber seals on the linear bearing trucks.

### 4.3. Linear Lubrication and Cleaning Procedure

The lubrication and cleaning process is outlined in the steps that follow. Before beginning lubrication, see Section 4.2. for recommended lubricants.



To minimize the possibility of bodily injury, confirm that all electrical power is disconnected prior to making any mechanical adjustments.

1. Remove power to the stage.
2. Remove any dirty or dried lubricant from the linear bearing guides. Use a clean, lint-free cloth. A swab soaked in isopropyl alcohol may be used to remove stubborn debris.
3. Apply a thin, continuous film of lubricant to the linear bearing guides. A good quality, natural bristle artist's brush makes an excellent applicator.
4. Using a grease gun with the appropriate fittings (see Section 4.2. ) add lubricant into the grease nipples of the bearing blocks. All grease nipples are accessible without removal of any components (total qty. 8, see Figure 4-1). Add lubricant until a small amount can be seen coming out of the bottom of the bearing block. If extra lubricant spills onto adjacent surfaces, it may be wiped off with a clean cloth.
5. Manually move the stage to the opposite end of travel to work the grease into the linear bearing guides.
6. Repeat steps 3 through 5 for any areas covered by the original table position.
7. Restore power to the stage and drive the stage table back to its original position to redistribute lubricants.

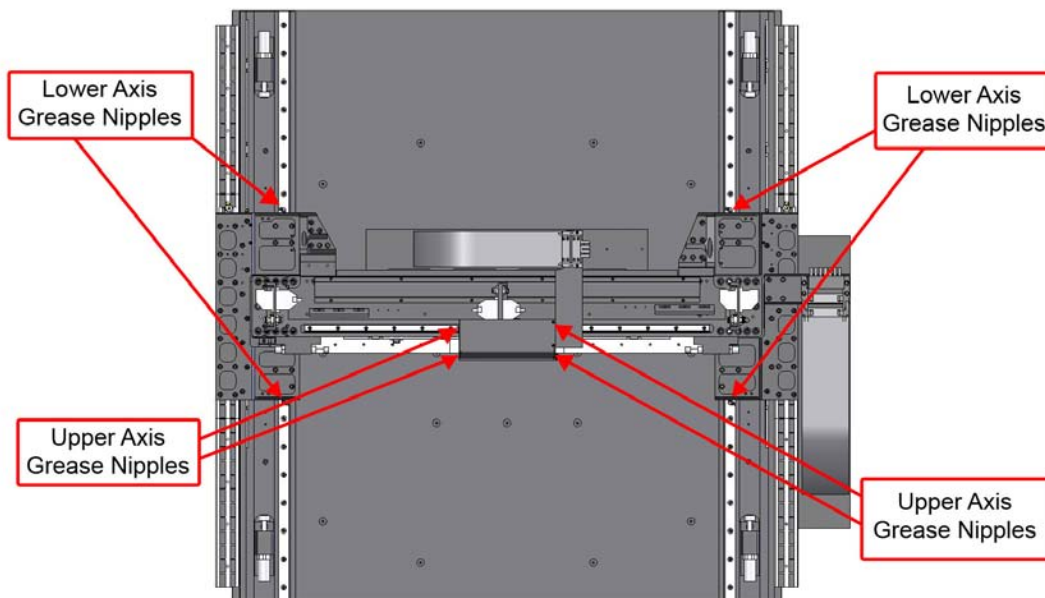

Figure 4-1: Location of Grease Nipples (approximate)

## 4.4. Linear Encoder Cleaning and Maintenance Procedure

The AGS15000 system utilizes a high precision, non-contact optical feedback device. Depending on the system environment, the encoder scale may need to be cleaned to ensure optimal encoder signal and system performance.



To minimize the possibility of bodily injury, confirm that all electrical power is disconnected prior to making any mechanical adjustments.

1. Remove power to the stage.
2. Remove the upper axis encoder cover (multiple pieces) to access the linear encoder scale.

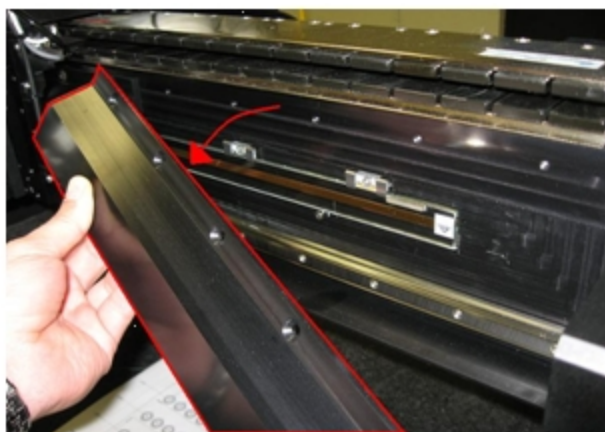

Figure 4-2: Removing Upper Axis Encoder Cover

3. Carefully clean the linear encoder scale using IPA and a swab, being sure to wipe the swab in the direction of the encoder grating (vertically). Allow the IPA to air dry completely prior to restoring power to the system.



DO NOT use an aggressive solvent (such as Acetone or similar) to clean the linear encoder as this may cause damage to the encoder scale.

4. Re-assemble any covers that were removed in Step 3.
5. Restore power to the stage and drive the system through travel to ensure proper encoder signal feedback.

## 4.5. System Calibration Procedure

If the HALAR option was purchased with the system, then the system was calibrated at the Aerotech factory to meet catalog accuracy and repeatability specifications. The parameter file provided with the system includes the calibration data for the axes and should be enabled in the controller in order to achieve the specified system accuracy. Other than thermal effects (see Section 0.1.), it is not anticipated that the accuracy will need to be re-calibrated in the field unless one of the following conditions occur:

- Shipping damage



WARNING

If any damage has occurred during shipping, report it immediately.

- Mechanical crash of the system due to system fault or programming error.



WARNING

If a mechanical crash of the system has occurred, report it immediately. Aerotech can assist in determining if any system damage has occurred.

- Field replacement or adjustment of the linear encoder scale or encoder read head.

## Appendix A: Warranty and Field Service

Aerotech, Inc. warrants its products to be free from defects caused by faulty materials or poor workmanship for a minimum period of one year from date of shipment from Aerotech. Aerotech's liability is limited to replacing, repairing or issuing credit, at its option, for any products that are returned by the original purchaser during the warranty period. Aerotech makes no warranty that its products are fit for the use or purpose to which they may be put by the buyer, where or not such use or purpose has been disclosed to Aerotech in specifications or drawings previously or subsequently provided, or whether or not Aerotech's products are specifically designed and/or manufactured for buyer's use or purpose. Aerotech's liability or any claim for loss or damage arising out of the sale, resale or use of any of its products shall in no event exceed the selling price of the unit.

Aerotech, Inc. warrants its laser products to the original purchaser for a minimum period of one year from date of shipment. This warranty covers defects in workmanship and material and is voided for all laser power supplies, plasma tubes and laser systems subject to electrical or physical abuse, tampering (such as opening the housing or removal of the serial tag) or improper operation as determined by Aerotech. This warranty is also voided for failure to comply with Aerotech's return procedures.

### ***Laser Products***

Claims for shipment damage (evident or concealed) must be filed with the carrier by the buyer. Aerotech must be notified within (30) days of shipment of incorrect materials. No product may be returned, whether in warranty or out of warranty, without first obtaining approval from Aerotech. No credit will be given nor repairs made for products returned without such approval. Any returned product(s) must be accompanied by a return authorization number. The return authorization number may be obtained by calling an Aerotech service center. Products must be returned, prepaid, to an Aerotech service center (no C.O.D. or Collect Freight accepted). The status of any product returned later than (30) days after the issuance of a return authorization number will be subject to review.

### ***Return Procedure***

After Aerotech's examination, warranty or out-of-warranty status will be determined. If upon Aerotech's examination a warranted defect exists, then the product(s) will be repaired at no charge and shipped, prepaid, back to the buyer. If the buyer desires an airfreight return, the product(s) will be shipped collect. Warranty repairs do not extend the original warranty period.

### ***Returned Product Warranty Determination***

After Aerotech's examination, the buyer shall be notified of the repair cost. At such time, the buyer must issue a valid purchase order to cover the cost of the repair and freight, or authorize the product(s) to be shipped back as is, at the buyer's expense. Failure to obtain a purchase order number or approval within (30) days of notification will result in the product(s) being returned as is, at the buyer's expense. Repair work is warranted for (90) days from date of shipment. Replacement components are warranted for one year from date of shipment.

### ***Returned Product Non-warranty Determination***

At times, the buyer may desire to expedite a repair. Regardless of warranty or out-of-warranty status, the buyer must issue a valid purchase order to cover the added rush service cost. Rush service is subject to Aerotech's approval.

### ***Rush Service***

**On-site Warranty Repair** If an Aerotech product cannot be made functional by telephone assistance or by sending and having the customer install replacement parts, and cannot be returned to the Aerotech service center for repair, and if Aerotech determines the problem could be warranty-related, then the following policy applies:

Aerotech will provide an on-site field service representative in a reasonable amount of time, provided that the customer issues a valid purchase order to Aerotech covering all transportation and subsistence costs. For warranty field repairs, the customer will not be charged for the cost of labor and material. If service is rendered at times other than normal work periods, then special service rates apply.

If during the on-site repair it is determined the problem is not warranty related, then the terms and conditions stated in the following "On-Site Non-Warranty Repair" section apply.

**On-site Non-warranty Repair** If any Aerotech product cannot be made functional by telephone assistance or purchased replacement parts, and cannot be returned to the Aerotech service center for repair, then the following field service policy applies:

Aerotech will provide an on-site field service representative in a reasonable amount of time, provided that the customer issues a valid purchase order to Aerotech covering all transportation and subsistence costs and the prevailing labor cost, including travel time, necessary to complete the repair.

**Company Address** Aerotech, Inc.  
101 Zeta Drive  
Pittsburgh, PA  
15238-2897

Phone: (412) 963-7470

Fax: (412) 963-7459

## Appendix B: Technical Changes

Table B-1: Current Changes (1.01.00)

Section(s) Affected	General Information
Section 1.5.	Section added
Section 3.1.	Section added
Chapter 2: Installation, Section 2.1. , Section 2.2. , and Section 1.4.	Safety information and warnings added
Section 3.3.	Specifications tables added

**Table B-2: Archived Changes**

Revision	Section(s) Affected	General Information
1.00.00	--	New manual



# Appendix C: Payload and Performance Plots

## Upper Axis Acceleration Plot:

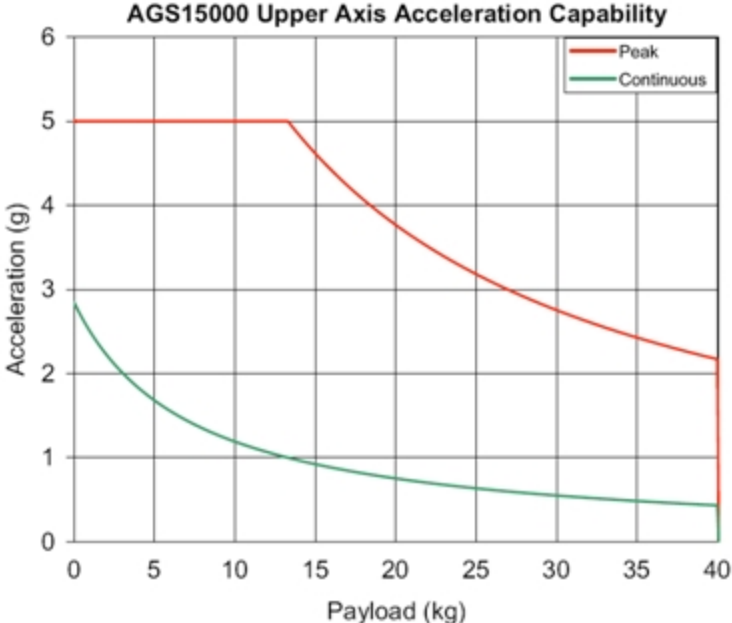

**Lower Axis Acceleration Plots:**

AGS15000HL with BLM motors:

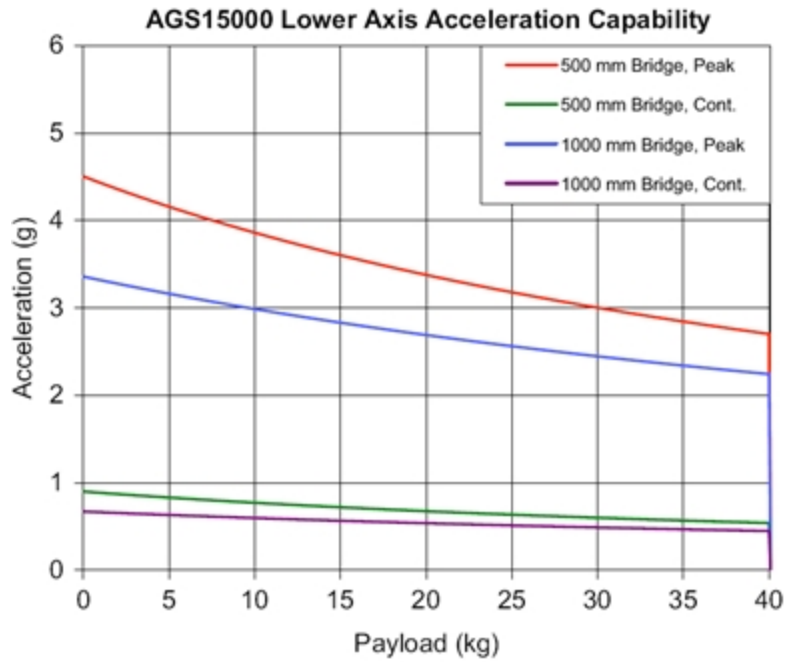

AGS15000HL with BLMH motors:

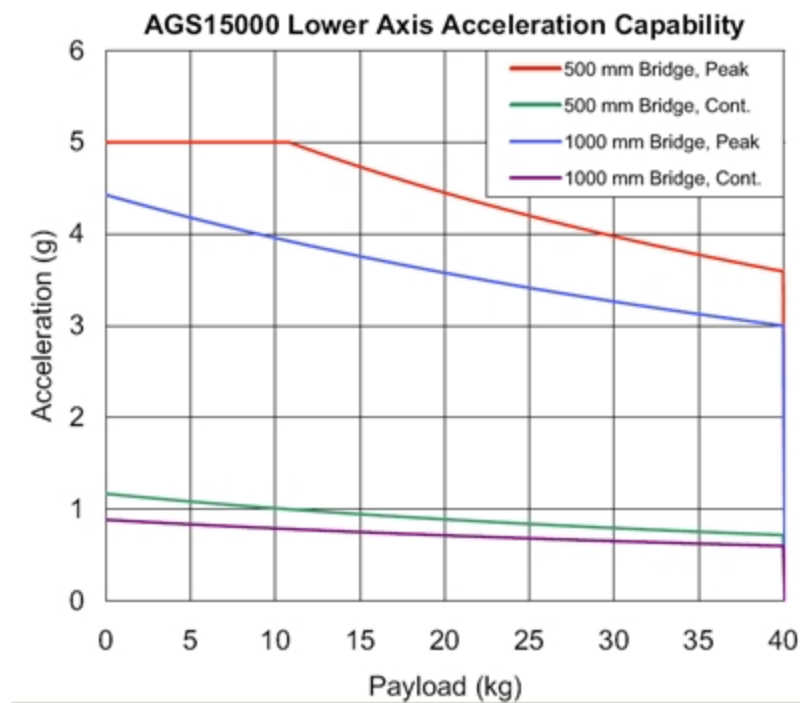

# Index

		<b>W</b>
		Warnings..... 6
<b>A</b>		
Air Requirements.....	12	
Attaching the Payload.....	12	
<b>C</b>		
cable.....	3, 12	
Cleaning.....	17	
<b>D</b>		
Declaration of Incorporation.....	8	
<b>E</b>		
Electrical Installation.....	12	
Environmental Specifications.....	13	
<b>L</b>		
Load Capability.....	13	
Lubrication.....	17	
lubrication schedule.....	17	
<b>M</b>		
Model Numbers.....	4, 9	
Mounting the System to a Machine Base.....	10	
<b>O</b>		
Optional Features.....	3	
Overtravel Safety.....	16	
<b>S</b>		
safety procedures.....	6	
Specifications.....	14	
Standard Features.....	2	
<b>U</b>		
Unpacking and Handling the Stage.....	9	



# Reader's Comments

**AGS15000HL Series Stage Manual**  
**P/N: EDS138, February 21, 2011**  
**Revision 1.01.00**

Please answer the questions below and add any suggestions for improving this document.



Is the manual:	Yes	No
Adequate to the subject		
Well organized		
Clearly presented		
Well illustrated		

How do you use this document in your job? Does it meet your needs? What improvements, if any, would you like to see? Please be specific or cite examples.

Stage/Product Details		Name	
<b>Model #</b>		Title	
<b>Serial #</b>		Company Name	
Date Shipped		Address	
Customer Order #			
Aerotech Subsidiary Order #		Email	

Mail your comments to:	Fax to:
Aerotech, Inc. 101 Zeta Drive Pittsburgh, PA 15238 U.S.A.	412-967-6870
	Email:
	service@aerotech.com

