

Cartesius

Cartesian Robot Series

Configurable T-style robot up to 1.0 m x 0.5 m x 0.3 m travel

Integrated cable management system (CMS) shortens your machine build

3-axis load up to 25 kg for demanding applications

Customizable Z and/or θ axis for easy integration of any process equipment

Teach mode with Aerotech controllers for fast deployment

Cartesius, Aerotech's industrial strength Cartesian robot, is built on the Aerotech Producer Series linear stages and is ideal for many automation applications including pick and place, assembly, test and inspection, dispensing stations, and many more.

Highly Configurable

Cartesius configurations include left or right handed XY, XYZ, and XZ systems. Stages can be side or base mounted and the Z axis can be base or carriage mounted. An optional rotary axis can be mounted to the Z. The integrated cable management is connectorized for easy disconnect for customer cables and air lines. All stages have environmental protection, servomotors with encoders, integral limits, and multiple ball-screw leads providing a wide range of speeds and resolutions.

Cable Management System

Aerotech's extensive design experience with 24/7 production equipment has resulted in an optimized CMS that is field proven to be the industry's most reliable design. Large bend radii and high-flex cables ensure that the Cartesius CMS provides millions of cycles of maintenance-free operation. In the unlikely event of a component failure, the modular design ensures that part replacement is fast and easy.

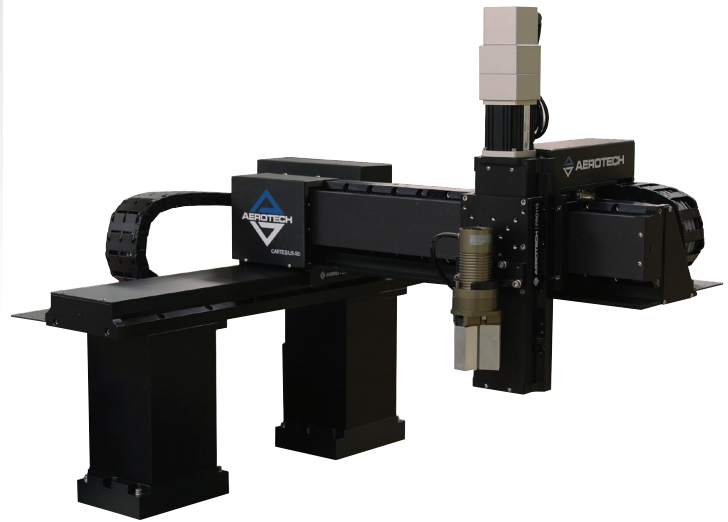

Customer cabling and pneumatics can be routed through the CMS system. Connectors are provided at the workpiece and at the base, greatly simplifying final machine integration.

Rugged Construction

Cartesius is configured with Aerotech's Producer Series stages: PRO115SL, PRO165SI, and PRO225SL. These precision ball-screw stages are driven with brushless servomotors with encoders for position feedback. The stages are designed with hard covers and side-seals for protection from debris. The robust aluminum cover is hard-coated to provide a scratch resistant surface. The side seals keep dirt and particulates out of the stage and protect the bearing surfaces and ball screw from contamination. The vertical orientation of the seals easily deflects debris away from the stage.

NEMA Flange-Mount

All stages have a NEMA flange-mounting interface for attachment of a wide variety of Aerotech and third-party motors. Aerotech can provide brush, brushless, and stepper motors preconfigured and mounted directly to the stage for integration with Aerotech controls. Or the stage can be purchased without the motor and cable management for the attachment of third-party motors.

Cartesius DESCRIPTION/SPECIFICATIONS

Aerotech's BMS series brushless, slotless servomotor with standard TTL encoder output provides a resolution of 0.5 to 2.5 micron. An optional analog output encoder can be coupled with external interpolation electronics to provide higher resolution (up to 5 nanometers). A holding brake can be added to the vertical axis motor, and a motor fold-back kit is available for space-constrained applications to reduce the overall stage length.

Turnkey Operation

Leverage our years of experience manufacturing precision positioning and control systems by selecting a turnkey system-level option. Typical options include Z-theta mechanisms, risers to accommodate automated parts handling equipment, and machine bases designed to

accommodate the entire electronics subsystem. Aerotech also manufactures a wide range of high-performance amplifiers and advanced motion controllers optimized for automation applications.

Gantry Robots

If a gantry-style robot is required for your application, refer to Aerotech's extensive gantry offerings. Aerotech gantry systems use our own brushless linear servomotors with high accuracy linear encoders. Aerotech gantries are deployed worldwide in numerous 24/7 industrial automation applications including assembly, pick & place, stencil cutting, fuel cell manufacturing, sensor testing, and more.

| CARTESIUS System Specifications | | | | | |
|---------------------------------|------|--------|---------------|-------------------|-------------------------|
| Configuration | Axis | Stage | Lead (mm/rev) | Travel Range (mm) | Maximum Velocity (mm/s) |
| Cartesius-SD | X | PRO165 | 5 | 250-600 | 300 |
| | Y | PRO115 | 5 | 250-600 | 300 |
| | Z | PRO115 | 5 | 50-300* | 300 |
| Cartesius-HD | X | PRO225 | 5 | 250-1000 | 220 |
| | Y | PRO165 | 5 | 250-600 | 300 |
| | Z | PRO115 | 5 | 50-300* | 300 |

Notes:

1. Z travel up to 300 mm is for base mounted Z stage. Carriage to carriage mounting travel is 150 mm.

| X-AXIS | | |
|--------------|-----|-------|
| STAGE | A | B |
| PRO165SL-250 | 486 | 409.9 |
| PRO165SL-300 | 536 | 434.9 |
| PRO165SL-400 | 636 | 484.9 |
| PRO165SL-500 | 736 | 534.9 |
| PRO165SL-600 | 836 | 584.9 |

| Y-AXIS | | | |
|--------------|-------|--------|-----|
| STAGE | C | D | E |
| PRO115SL-250 | 307.5 | 737.5 | - |
| PRO115SL-300 | 332.5 | 787.5 | - |
| PRO115SL-400 | 382.5 | 887.4 | - |
| PRO115SL-500 | 432.5 | 987.4 | 300 |
| PRO115SL-600 | 482.5 | 1087.4 | 400 |

| OPTIONAL Z-AXIS | | |
|-----------------|-----|-----|
| STAGE | F | G |
| PRO115SL-050 | 286 | 170 |
| PRO115SL-100 | 336 | 195 |
| PRO115SL-150 | 386 | 220 |
| PRO115SL-200 | 436 | 245 |
| PRO115SL-250 | 486 | 270 |
| PRO115SL-300 | 536 | 295 |

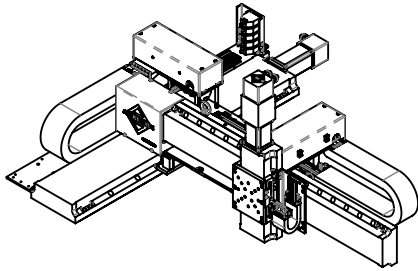

RIGHT HAND (-RH) CONFIGURATION

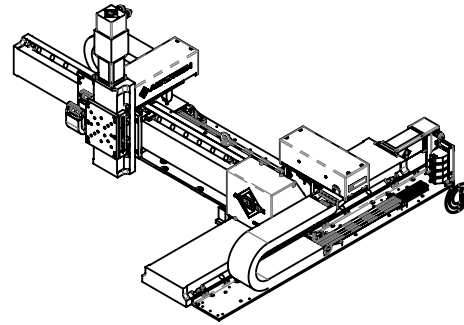

LEFT HAND (-LH) CONFIGURATION

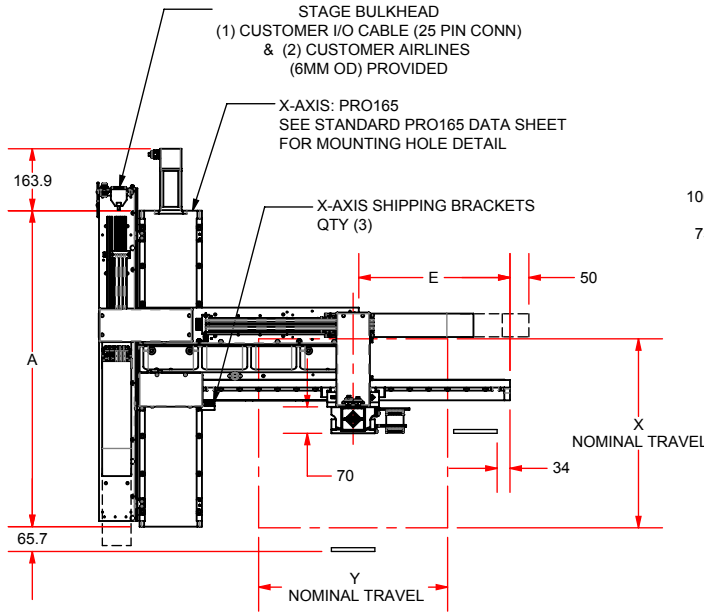

Y-AXIS TABLETOP FOR XYCONFIG. (12 THK.) $\triangle 1$
-TTM [-TTU]

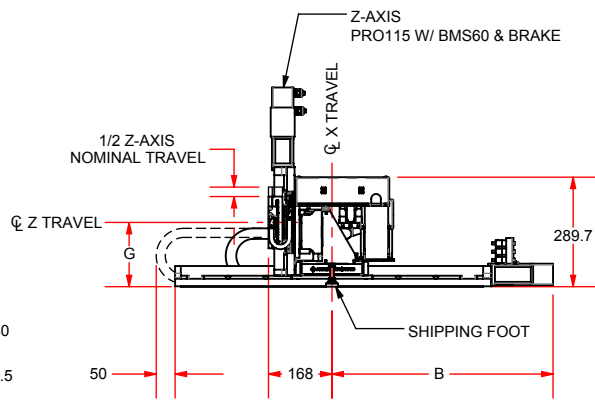
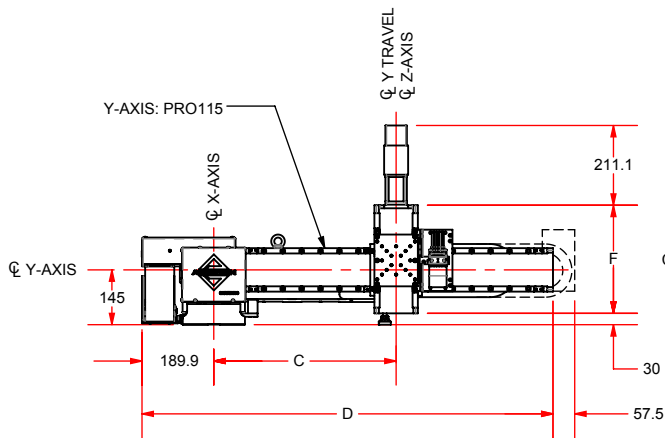
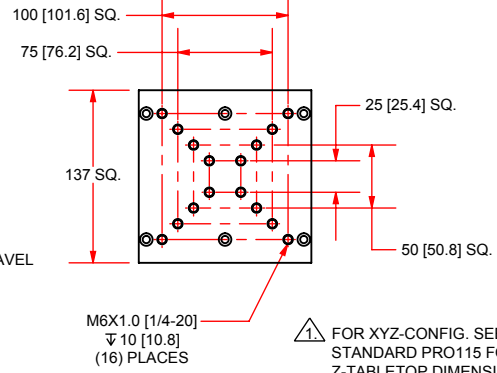

DIMENSIONS: MILLIMETERS

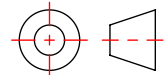

Cartesius-SD Riser DIMENSIONS

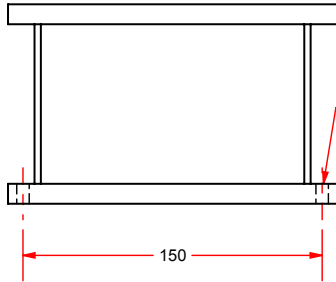
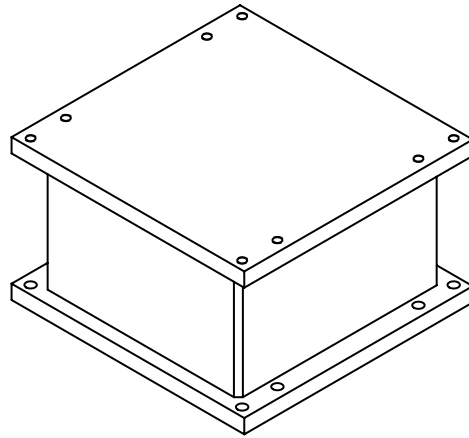
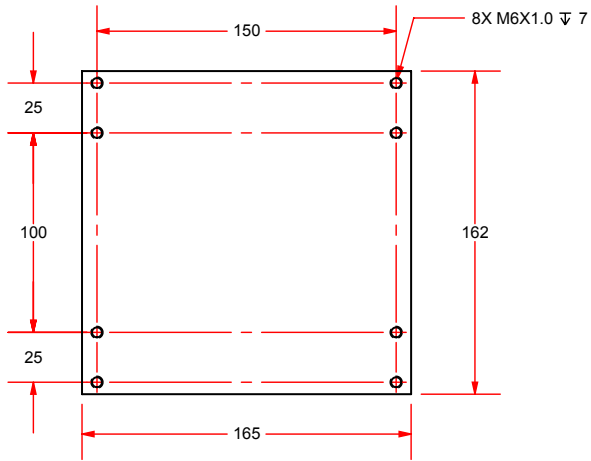

CLEARANCE HOLES
FOR M6 SHCS
(8) PLACES

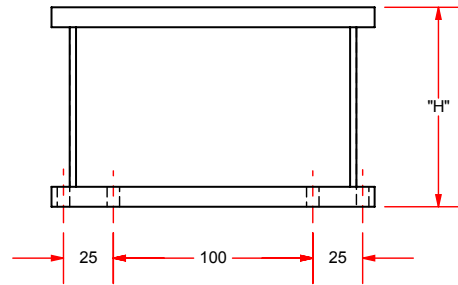

| BASIC MODEL | HEIGHT "H" |
|-------------|------------|
| HDR165-100 | 100 |
| HDR165-300 | 300 |

DIMENSIONS: MILLIMETERS

Cartesius-HD DIMENSIONS

| X-AXIS | | |
|---------------|------|-------|
| STAGE | A | B |
| PRO225SL-0250 | 636 | 514.8 |
| PRO225SL-0300 | 686 | 539.8 |
| PRO225SL-0400 | 786 | 589.8 |
| PRO225SL-0500 | 886 | 639.8 |
| PRO225SL-0600 | 986 | 689.8 |
| PRO225SL-0800 | 1186 | 789.8 |
| PRO225SL-1000 | 1386 | 889.8 |

| Y-AXIS | | | |
|--------------|-------|--------|-----|
| STAGE | C | D | E |
| PRO165SL-250 | 337.5 | 797.4 | - |
| PRO165SL-300 | 362.5 | 847.4 | - |
| PRO165SL-400 | 412.5 | 947.4 | - |
| PRO165SL-500 | 462.5 | 1047.4 | 300 |
| PRO165SL-600 | 512.5 | 1147.4 | 400 |

| OPTIONAL Z-AXIS | | |
|-----------------|-----|-------|
| STAGE | F | G |
| PRO115SL-050 | 286 | 172.5 |
| PRO115SL-100 | 336 | 197.5 |
| PRO115SL-150 | 386 | 222.5 |
| PRO115SL-200 | 436 | 247.5 |
| PRO115SL-250 | 486 | 272.5 |
| PRO115SL-300 | 536 | 297.5 |

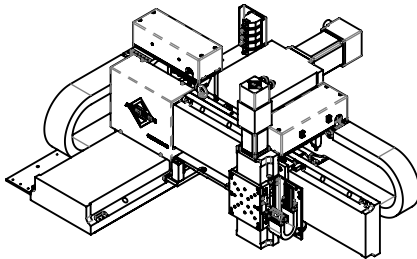

RIGHT HAND (-RH) CONFIGURATION

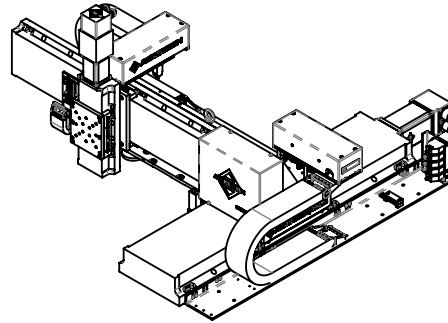

LEFT HAND (-LH) CONFIGURATION

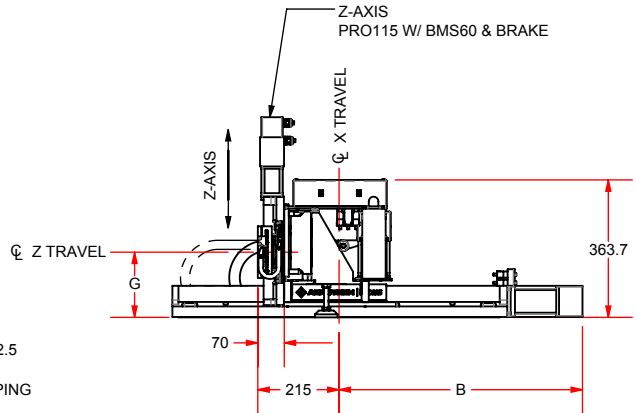
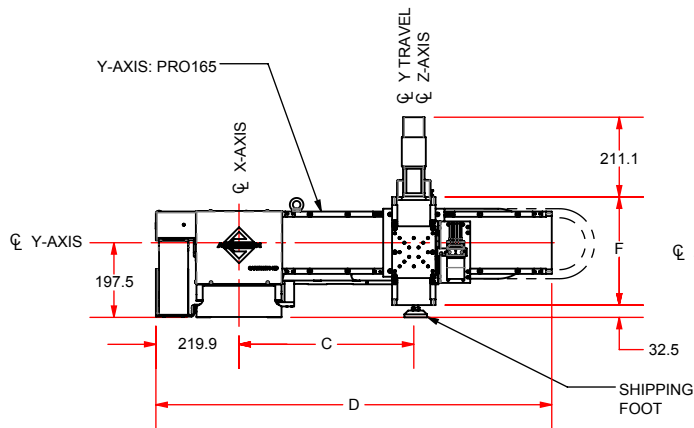
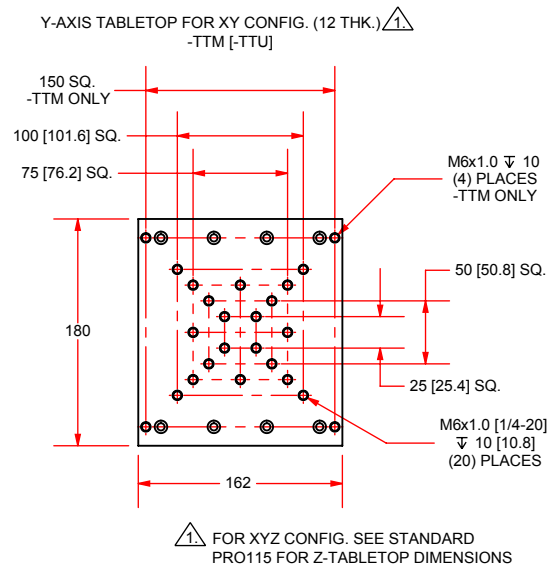
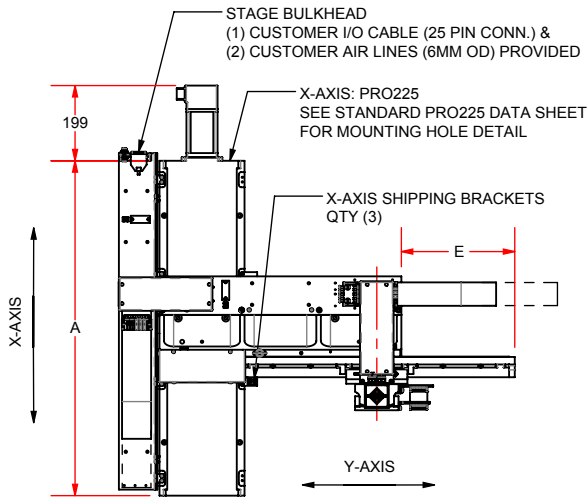

DIMENSIONS: MILLIMETERS

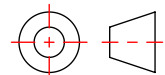

Cartesius-HD Riser DIMENSIONS

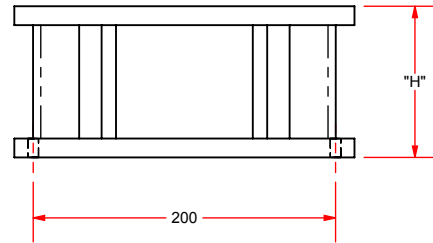
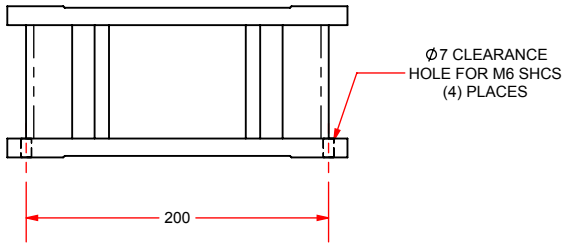
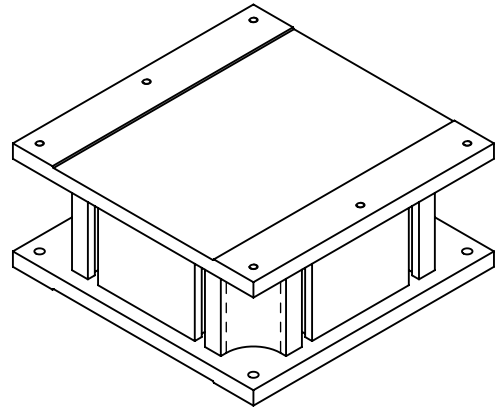
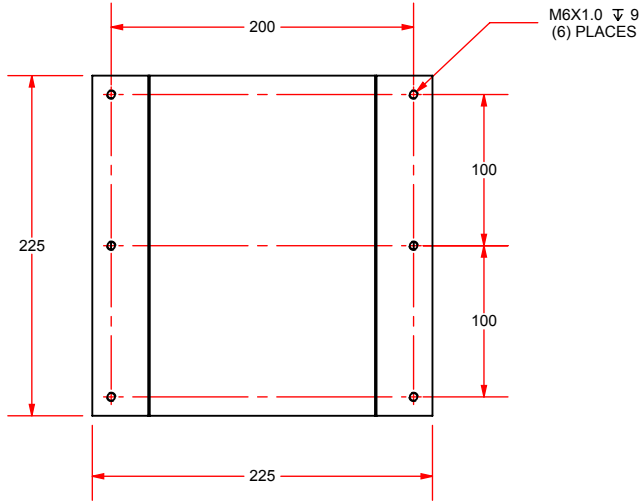

| BASIC MODEL | HEIGHT "H" |
|-------------|------------|
| HDR225-100 | 100 |
| HDR225-300 | 300 |

DIMENSIONS: MILLIMETERS

Cartesius-SD ORDERING INFORMATION

Please **CONTACT** an Aerotech Application Engineer to discuss your requirements.