

# AGV-HP(O) HIGH ACCURACY, THERMALLY STABLE GALVO SCANNER



## Calibrate Micron-Level Accuracy, Count on Ultimate Stability

With AGV-HP(O), which offers the highest level of accuracy of any laser scanner, you'll produce consistent parts with smaller, more precise features. The AGV-HP(O)'s highly repeatable and thermally stable feedback sensors can be calibrated down to single-digit, micron-level accuracy over the field of view (see figure below). With the extremely low thermal gain drift performance of the position transducers, complex, high-density laser machining applications that take long periods of time to complete will maintain consistent micron-level feature placement accuracy over the lifetime of the process. Likewise, high-throughput applications will maintain consistent part-to-part quality without having to re-calibrate between parts. For the highest level of thermal stability, the AGV-HP(O) scanners can be equipped with water cooling to stabilize the operating temperature of the device under varying loads, changes in ambient temperature or beam clipping on the input aperture.

- Attains single-digit, micron-level accuracy throughout the field of view
- Improves thermal stability significantly with optical feedback technology
- Delivers industry-best resolution of >24 bits when used with Aerotech's GCL controller
- Includes wide range of apertures and focal lengths
- Offers many choices of mirror surface treatments for a variety of laser wavelengths

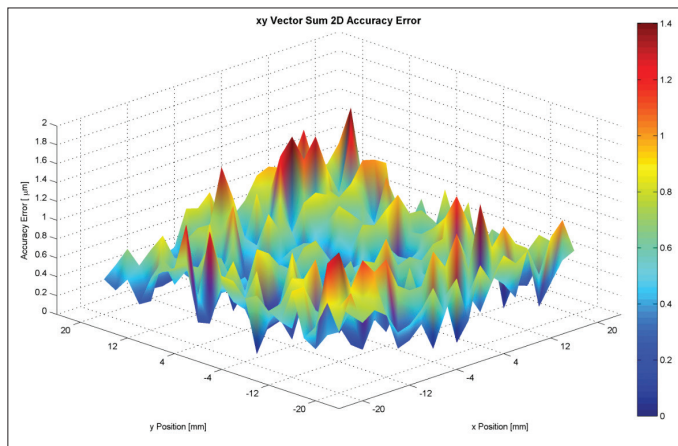

Nmark AGV-HP(O) provides industry-best micron-level 2D accuracy over the entire field of view.

Mechanical Specifications	AGV10HP(O)	AGV14HP(O)	AGV20HP(O)	AGV30HP(O)	
<b>Optical Performance</b>					
Beam Aperture	10 mm	14 mm	20 mm	30 mm	
Maximum Scan Angle	±20°				
Beam Displacement	12.6 mm	16.5 mm	23.2 mm	35.7 mm	
Feedback Resolution	0.012 μrad (25 bit)				
Dither (Min. Incremental Motion) <sup>(2)</sup>	<0.4 μrad <sub>rms</sub>				
Accuracy	50 μrad pk-pk				
Repeatability <sup>(3)</sup>	0.4 μrad <sub>rms</sub>				
Gain Error	0.05 mrad				
Non-Linearity	0.005%				
<b>Dynamic Performance</b>					
Tracking Error	0 μsec				
Peak Acceleration <sup>(4,5)</sup>	288,000 m/s <sup>2</sup>	224,000 m/s <sup>2</sup>	80,000 m/s <sup>2</sup>	56,000 m/s <sup>2</sup>	
Continuous Acceleration <sup>(4,6)</sup>	75,200 m/s <sup>2</sup>	56,000 m/s <sup>2</sup>	20,800 m/s <sup>2</sup>	19,200 m/s <sup>2</sup>	
Positioning Speed <sup>(4)</sup>	75 m/s	75 m/s	50 m/s	20 m/s	
Marking Speed <sup>(4, 7, 8)</sup>	5 m/s	5 m/s	5 m/s	5 m/s	
Jump & Settle Time, 1 mm Move <sup>(4,9)</sup>	270 μsec	270 μsec	450 μsec	700 μsec	
<b>Stability</b>					
Long-Term Drift <sup>(3)</sup>	Offset	10 μrad/12 hrs			
	Gain	15 μrad/24 hrs			
Thermal Drift	Offset	10 μrad/°C			
	Gain	1 ppm/°C			
<b>Mechanical Specifications</b>					
Mass	-HP	4.1 kg	4.4 kg	5.1 kg	5.8 kg
	-HPO	2.5 kg	2.6 kg	2.9 kg	3.1 kg
Material	Aluminum (black anodize and blue paint)				
MTBF (Mean Time Between Failure)	20,000 Hours				

Notes:

1. All angles are optical unless otherwise specified
2. Without -AC air cooling option
3. After initial 3 hour warm-up, ambient temperature variation <±0.5 deg C
4. Typical performance with f = 160mm F-Theta objective
5. Based on maximum rated current of the motor
6. Based on rated rms current of the motor with -WC water cooling option; maximum continuous acceleration is 70% of this value without water cooling
7. Achievable with < 1% velocity error over continuous velocity portion of move
8. Marking speed is dependent on allowable tracking error
9. Settled to within 1% of move distance
10. All specifications are per axis unless otherwise noted

Electrical Specifications	AGV10HP(O)	AGV14HP(O)	AGV20HP(O)	AGV30HP(O)
Drive System	Brushless direct-drive galvano motor			
Feedback	Noncontact rotary encoder			
Maximum Bus Voltage	±40 VDC			
Limit Switches	Optical limit switches and software limits			
Home Switch	At center			

AGV10HP-BE1

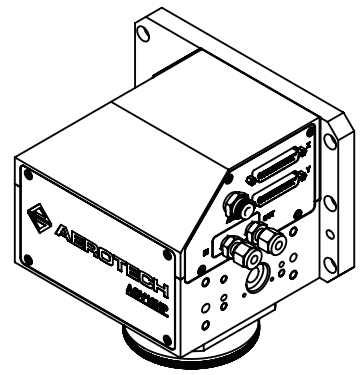
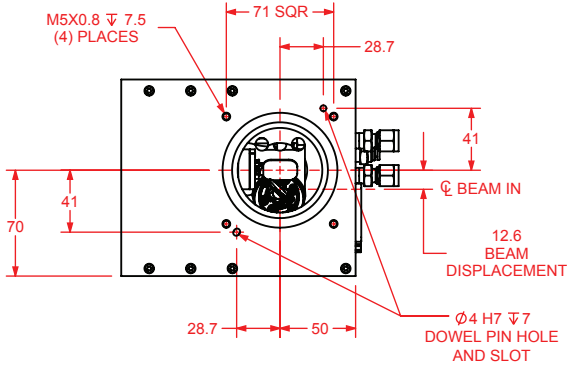
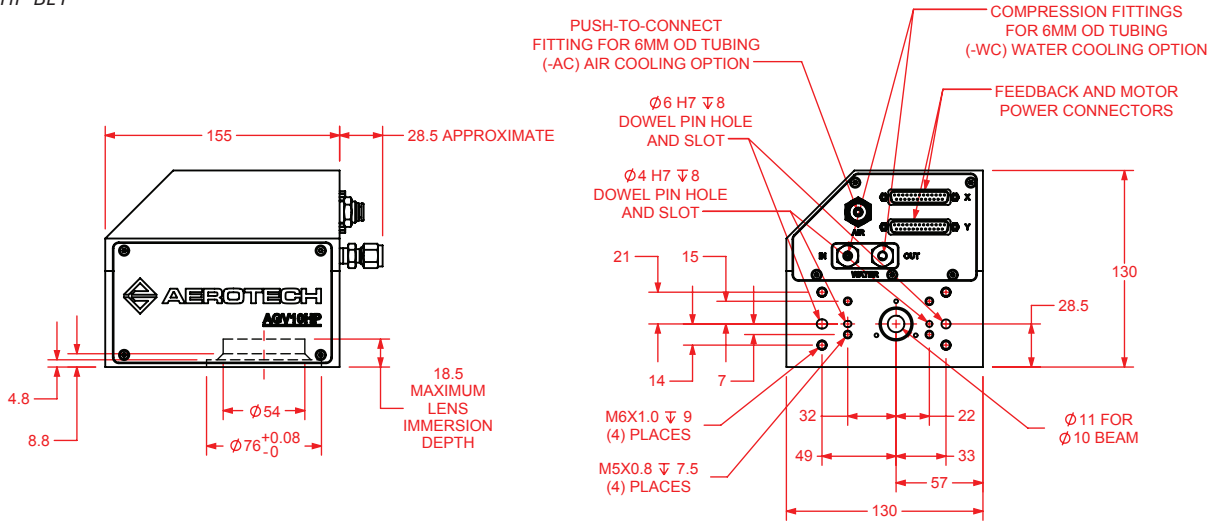

(-L3) F-THETA LENS  
 (-MP) MOUNTING PLATE OPTION  
 (-AC) AIR COOLING OPTION  
 (-WC) WATER COOLING OPTION

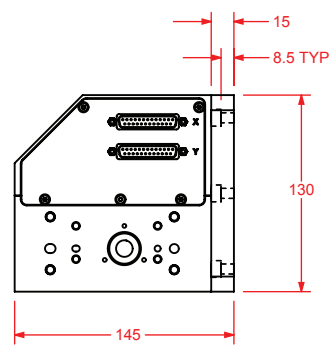
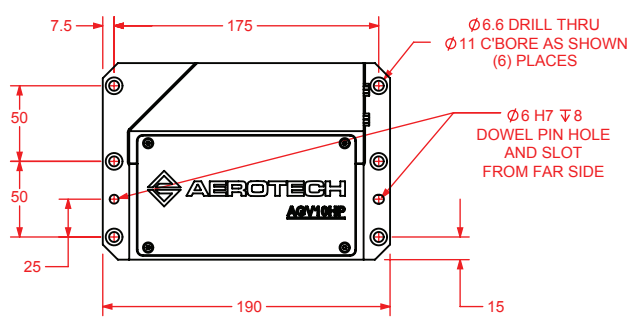
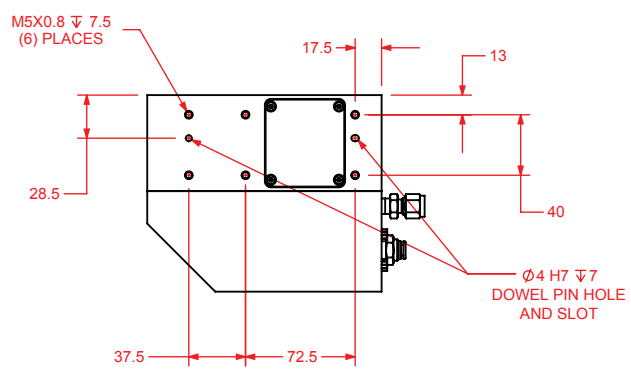

SIDE VIEW  
 (-MP) MOUNTING PLATE &  
 NO COOLING OPTIONS

END VIEW  
 (-MP) MOUNTING PLATE &  
 NO COOLING OPTIONS

DIMENSIONS: MILLIMETERS

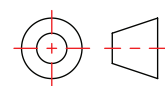

AGV10HP-BE2

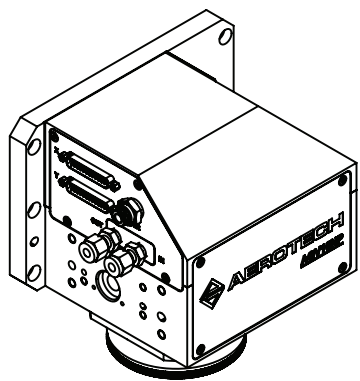
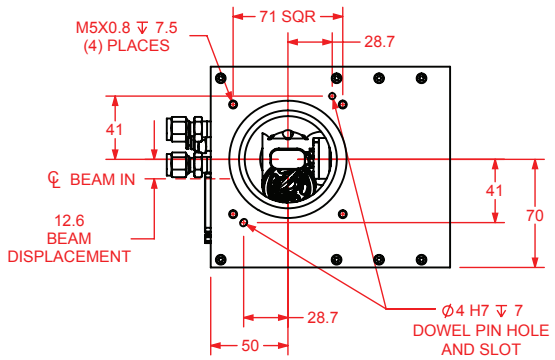
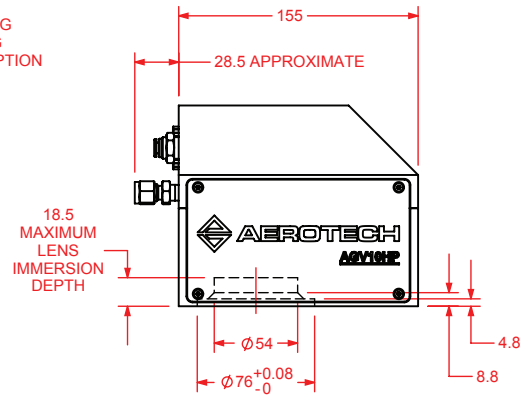
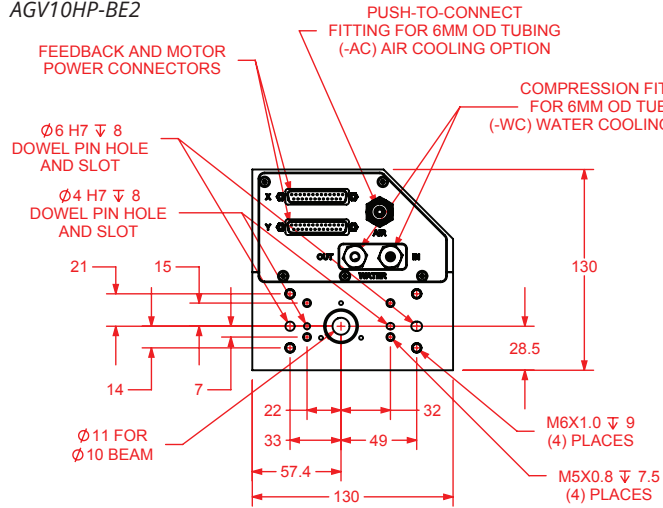

(-L3) F-THETA LENS  
 (-MP) MOUNTING PLATE OPTION  
 (-AC) AIR COOLING OPTION  
 (-WC) WATER COOLING OPTION

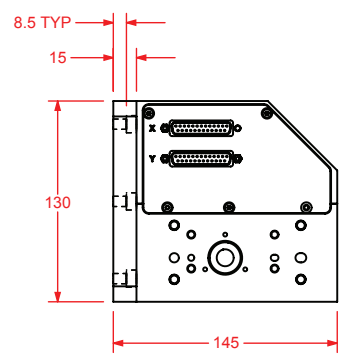
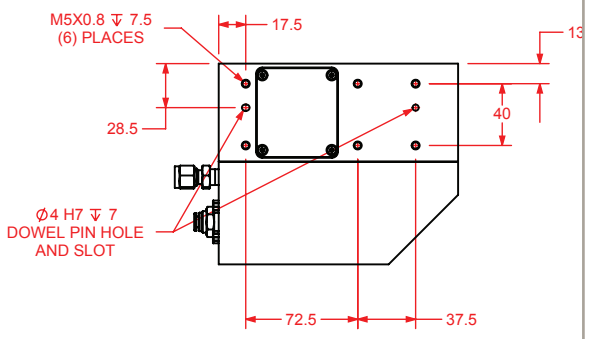

END VIEW  
 (-MP) MOUNTING PLATE &  
 NO COOLING OPTIONS

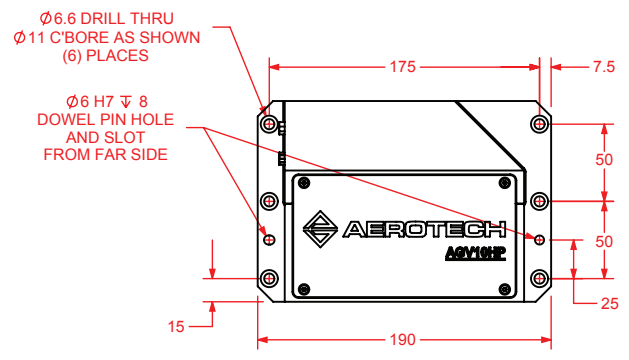

SIDE VIEW  
 (-MP) MOUNTING PLATE &  
 NO COOLING OPTIONS

DIMENSIONS: MILLIMETERS



AGV10HPO-BE1

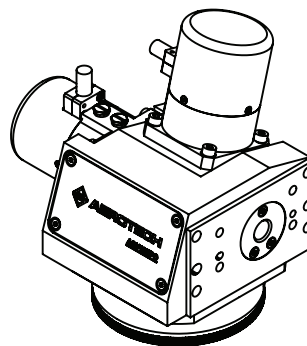
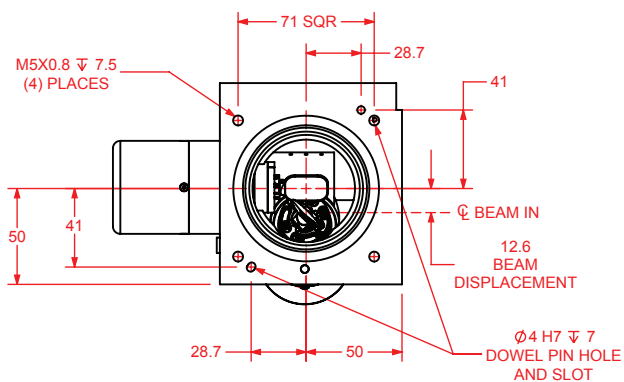
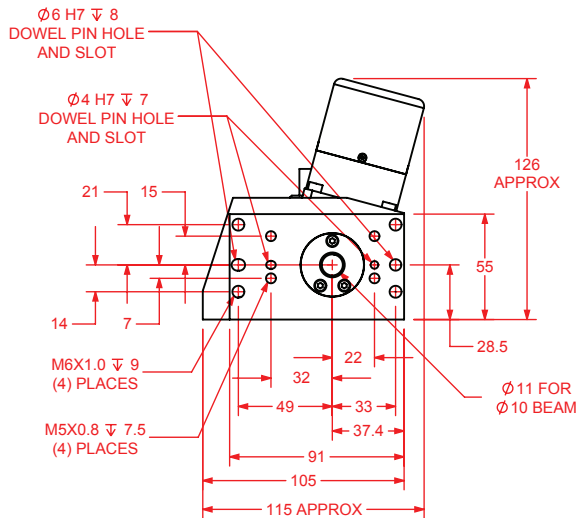
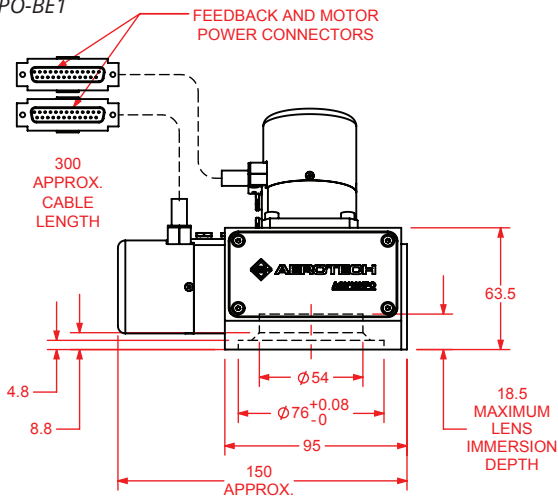

(-L3) F-THETA LENS  
NO COOLING OPTIONS

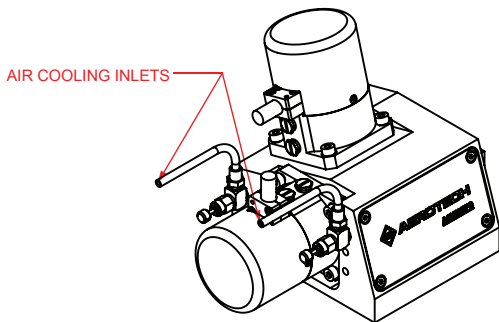
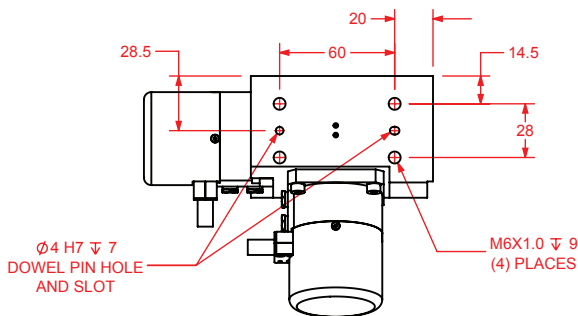

(-AC) AIR COOLING OPTION

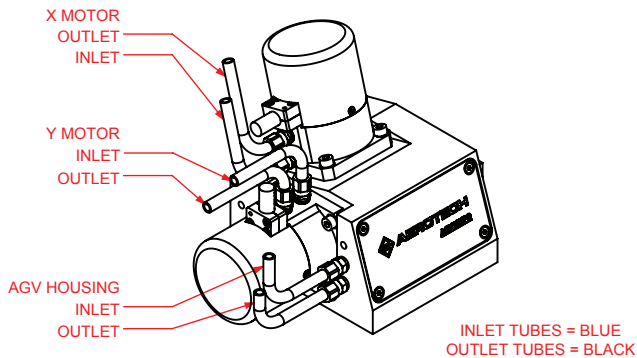

(-WC) WATER COOLING OPTION

DIMENSIONS: MILLIMETERS

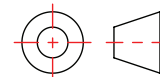

AGV10HPO-BE2

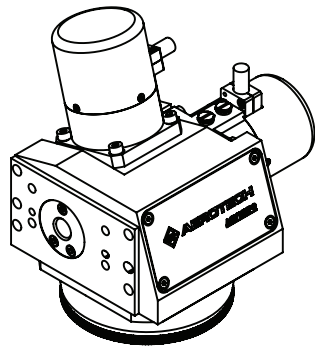
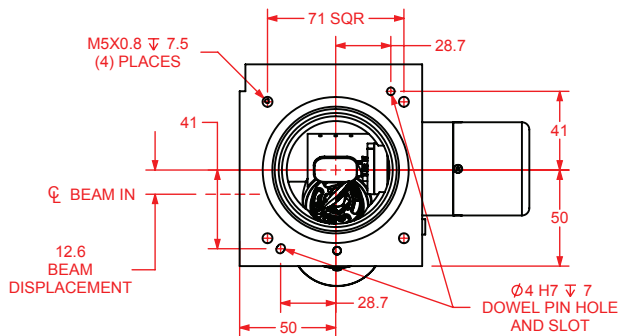
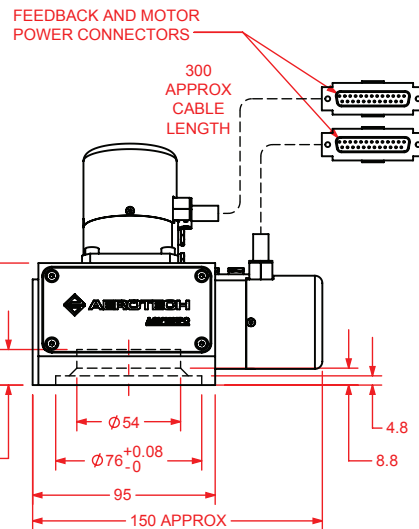
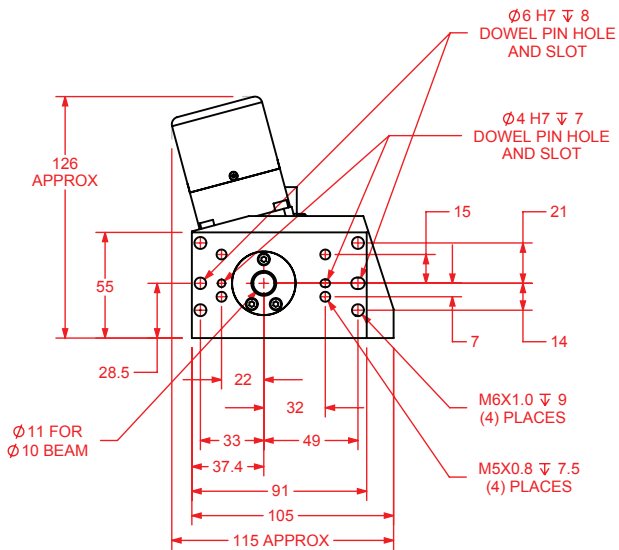

(-L3) F-THETA LENS  
NO COOLING OPTIONS

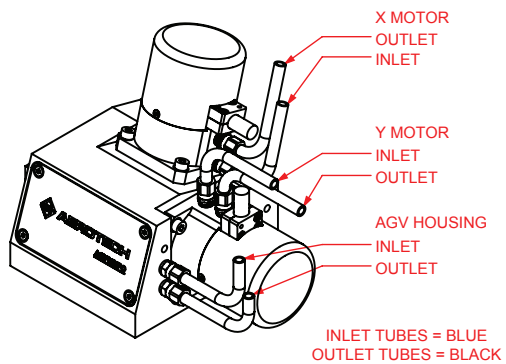
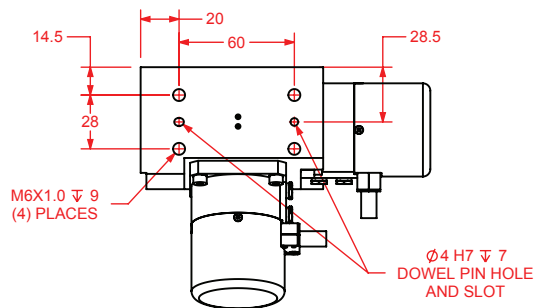

(-WC) WATER COOLING OPTION

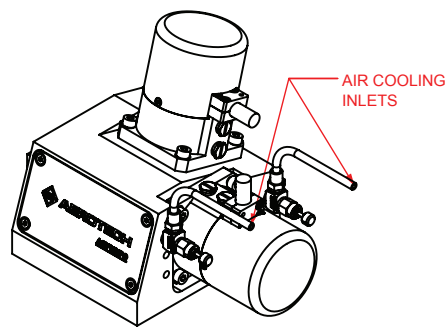

(-AC) AIR COOLING OPTION

DIMENSIONS: MILLIMETERS

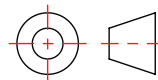

AGV14HP-BE1

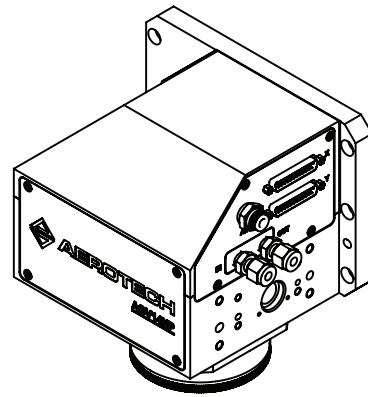
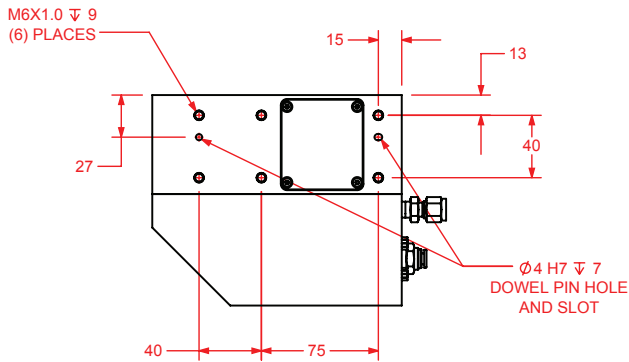
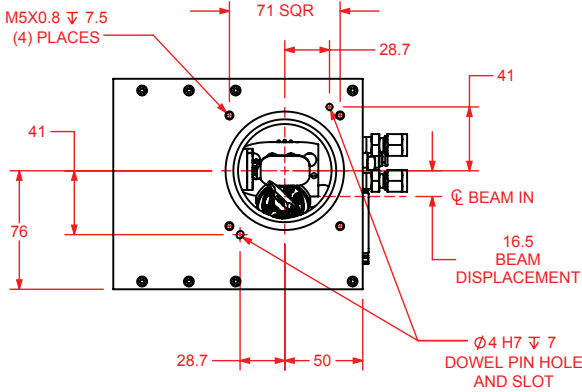
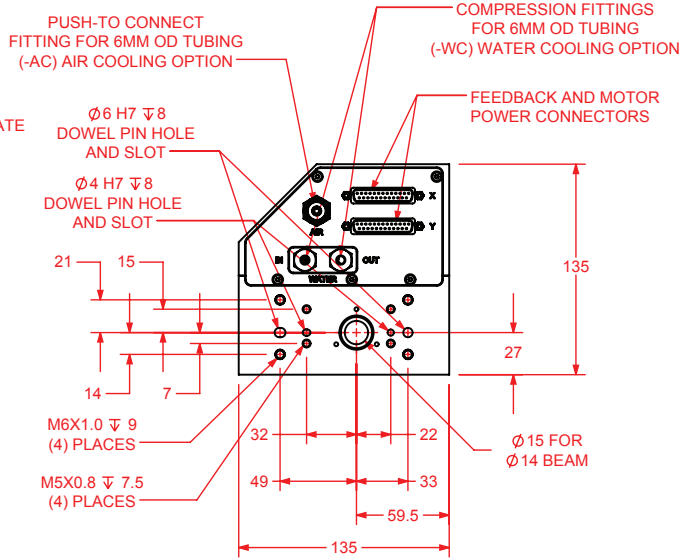
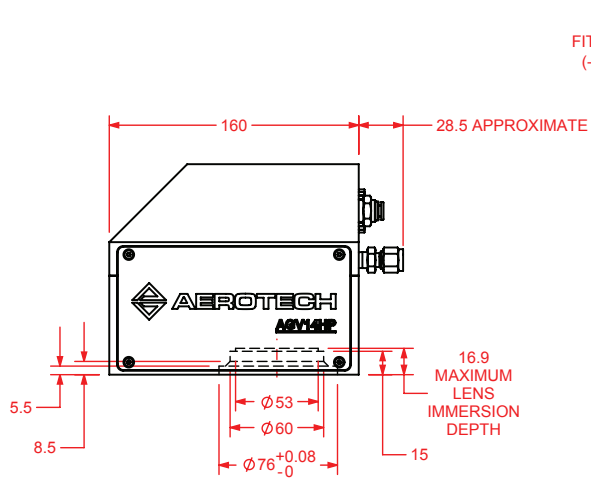

(-L5) F-THETA LENS  
(-MP) MOUNTING PLATE OPTION  
(-AC) AIR COOLING OPTION  
(-WC) WATER COOLING OPTION

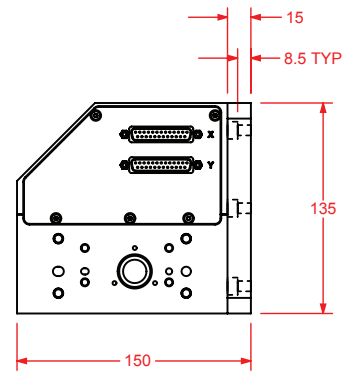
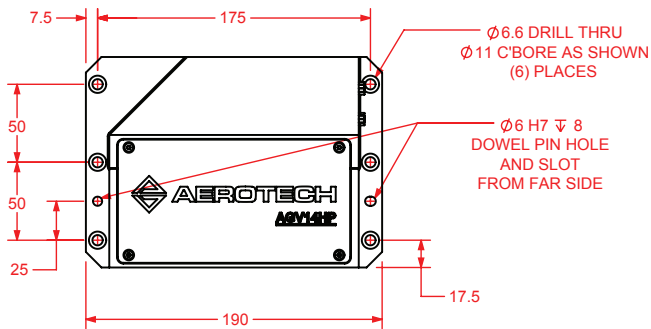

SIDE VIEW  
(-MP) MOUNTING PLATE &  
NO COOLING OPTIONS

DIMENSIONS: MILLIMETERS

END VIEW  
(-MP) MOUNTING PLATE &  
NO COOLING OPTIONS

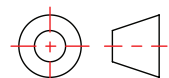

AGV14HP-BE2

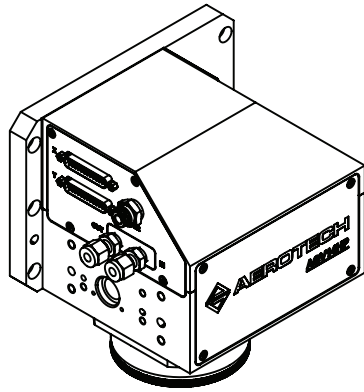
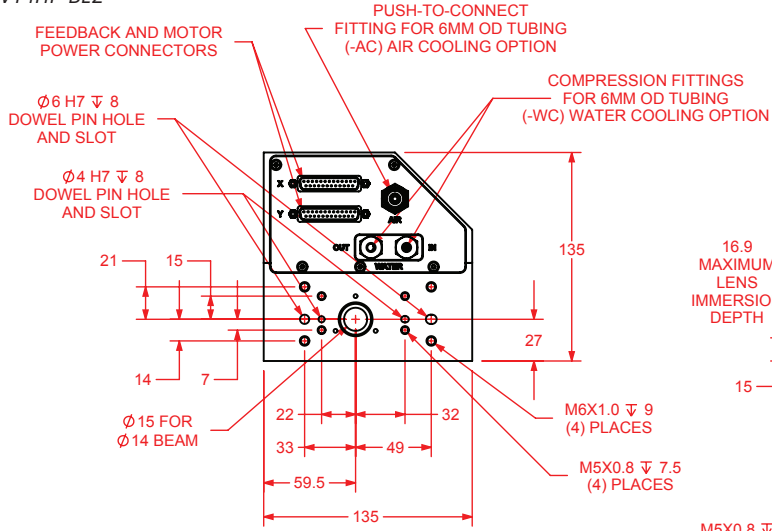

(-L5) F-THETA LENS  
 (-MP) MOUNTING PLATE OPTION  
 (-AC) AIR COOLING OPTION  
 (-WC) WATER COOLING OPTION

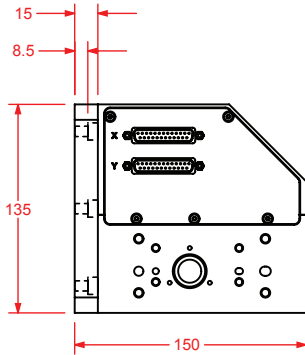
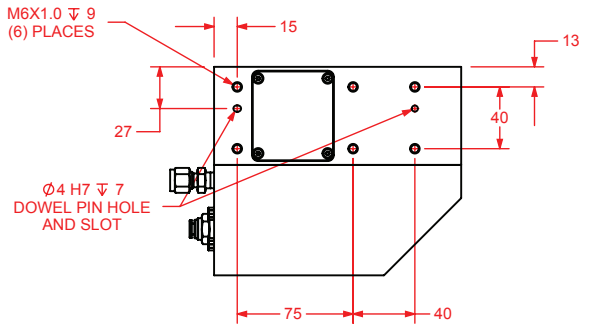
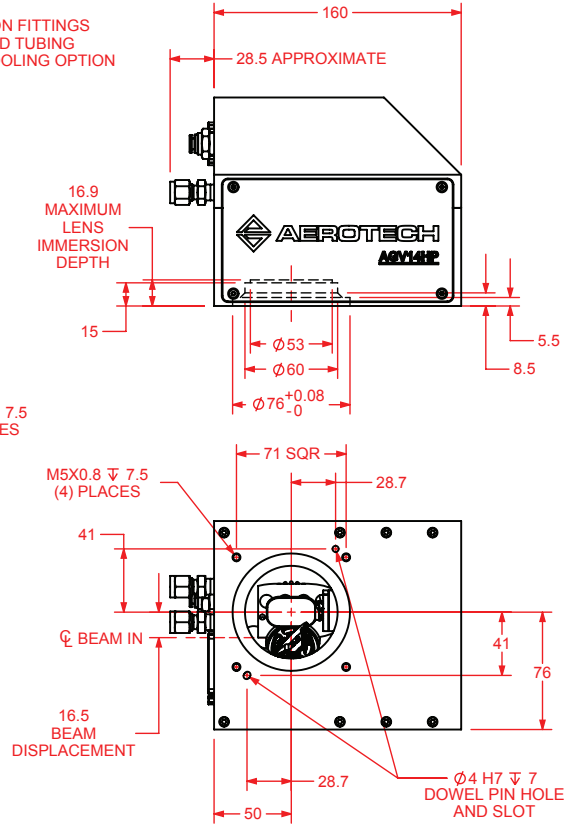

END VIEW  
 (-MP) MOUNTING PLATE &  
 NO COOLING OPTIONS

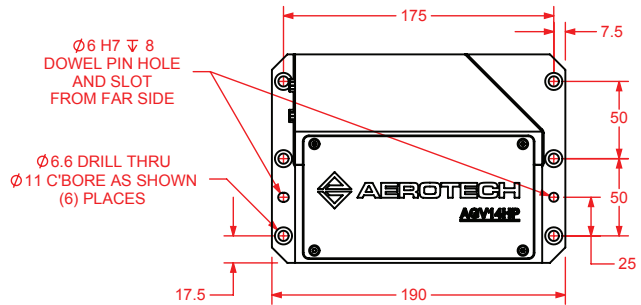

SIDE VIEW  
 (-MP) MOUNTING PLATE &  
 NO COOLING OPTIONS

DIMENSIONS: MILLIMETERS

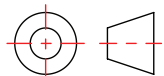



AGV14HPO-BE1

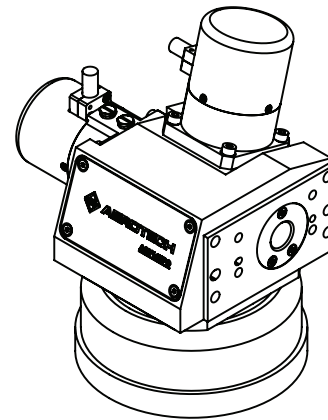
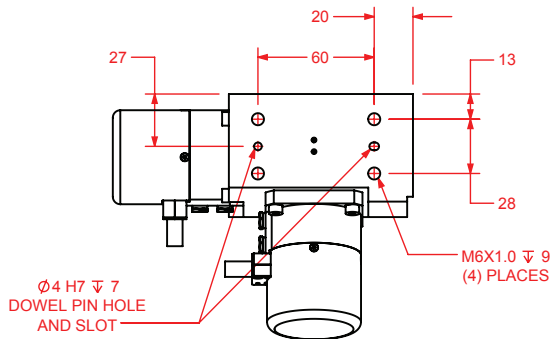
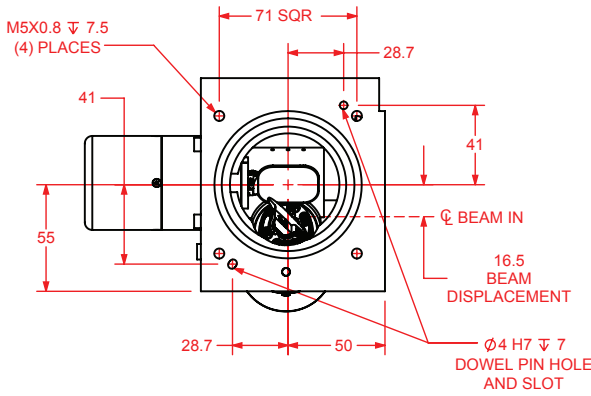
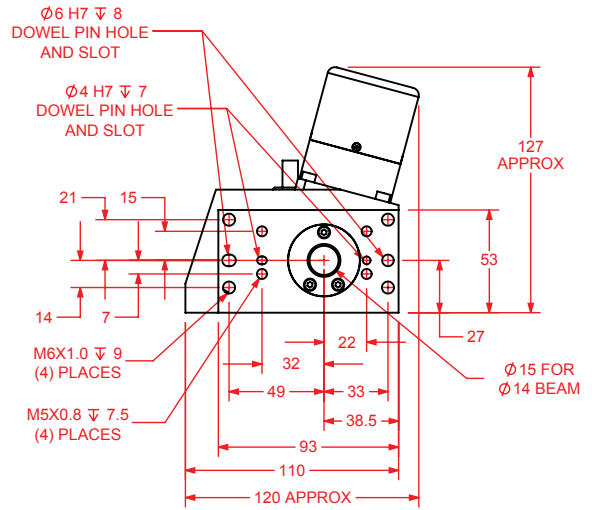
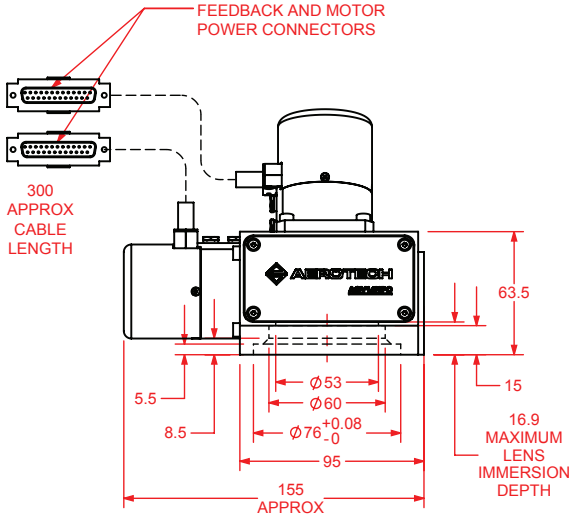

(-L9) F-THETA LENS OPTION  
NO COOLING OPTIONS

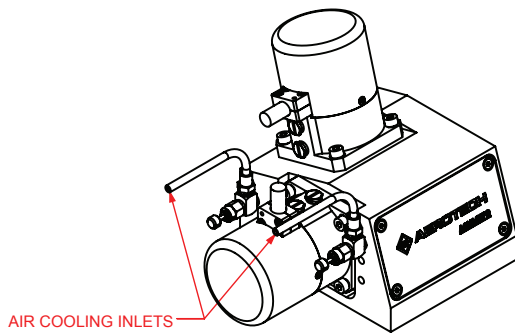

(-AC) AIR COOLING OPTION

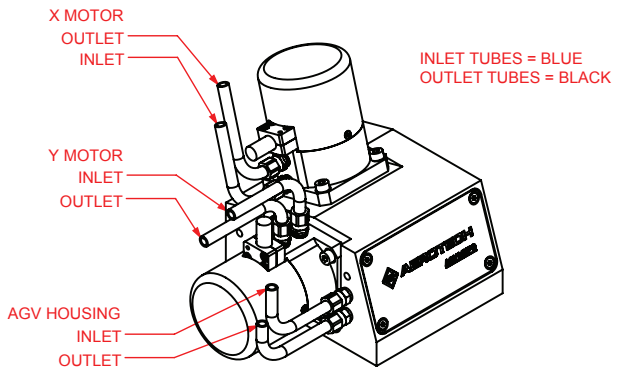

(-WC) WATER COOLING OPTION

DIMENSIONS: MILLIMETERS

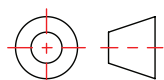

AGV14HPO-BE2

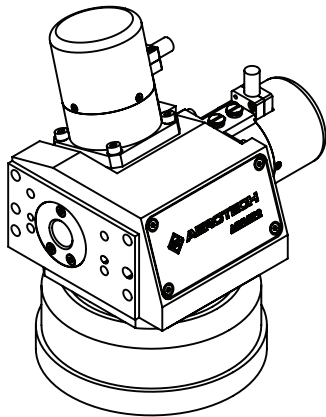
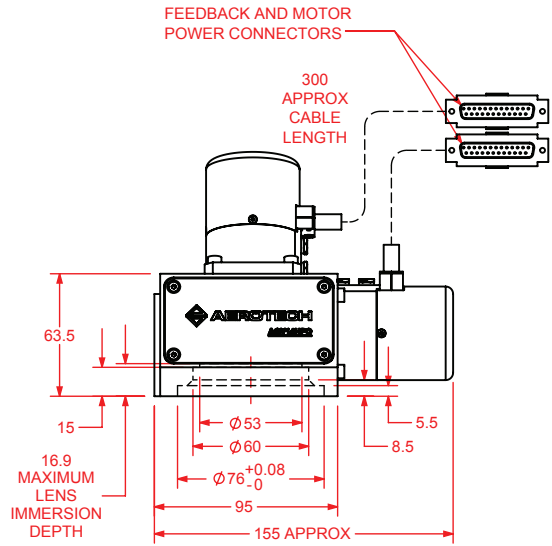
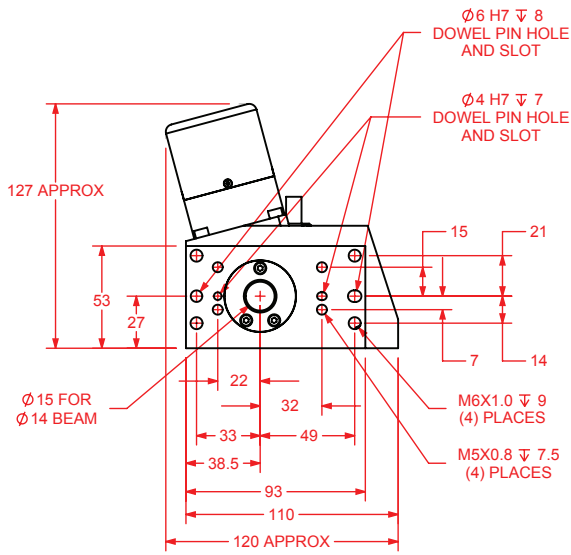

(-L9) F-THETA LENS  
NO COOLING OPTIONS

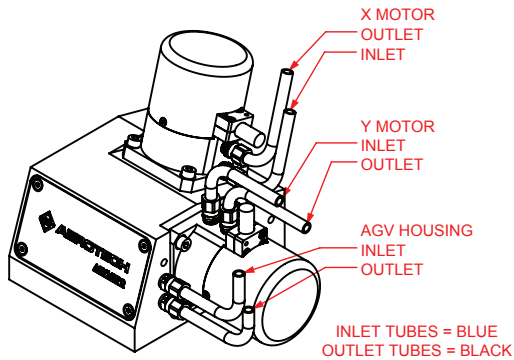
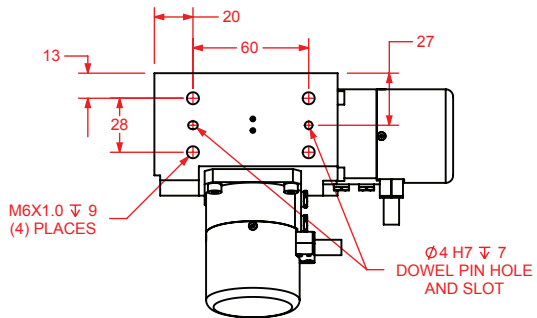
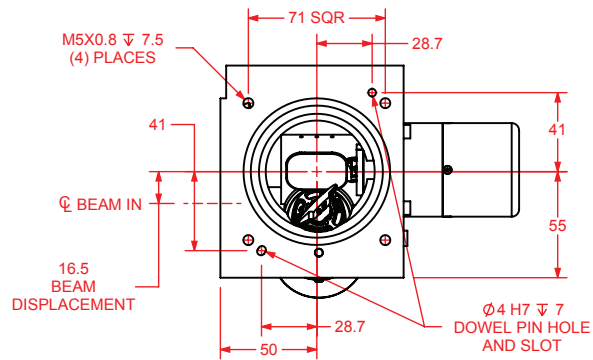

(-WC) WATER COOLING OPTION

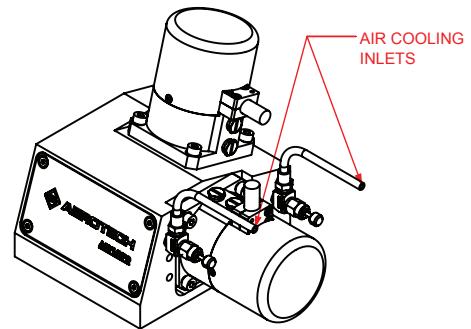

(-AC) AIR COOLING OPTION

DIMENSIONS: MILLIMETERS

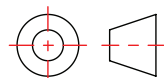

AGV20HP-BE1

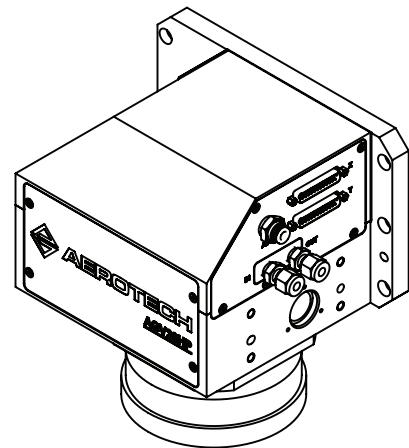
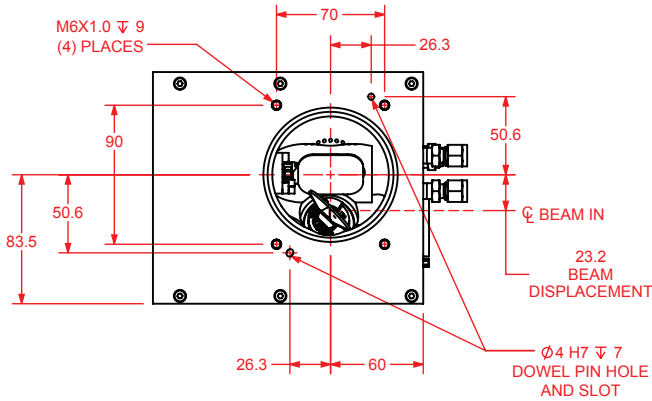
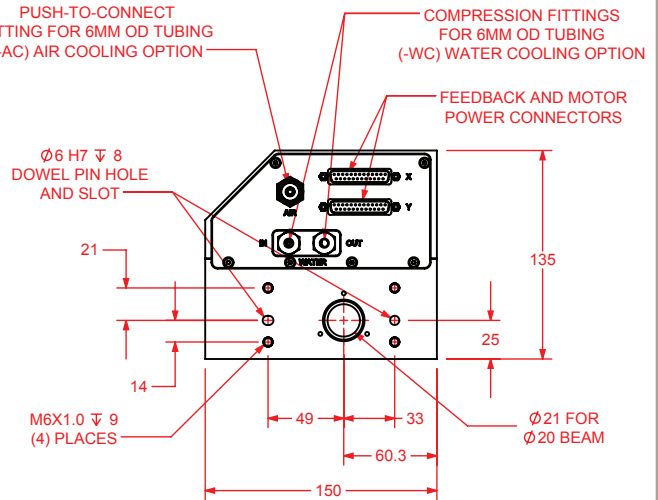
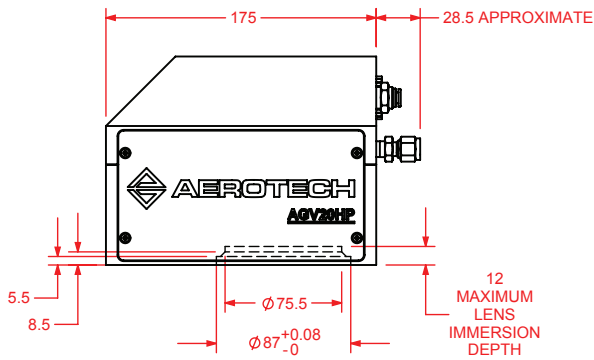

(-L7) F-THETA LENS  
 (-MP) MOUNTING PLATE OPTION  
 (-AC) AIR COOLING OPTION  
 (-WC) WATER COOLING OPTION

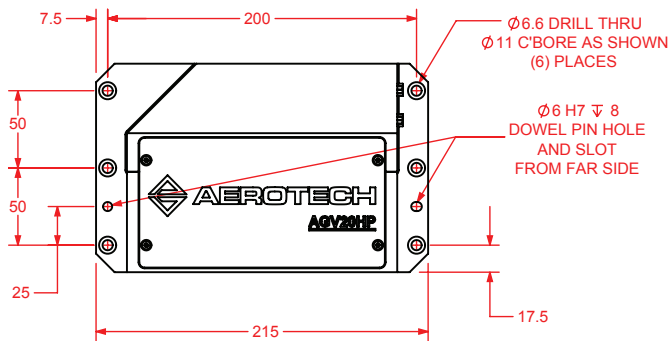
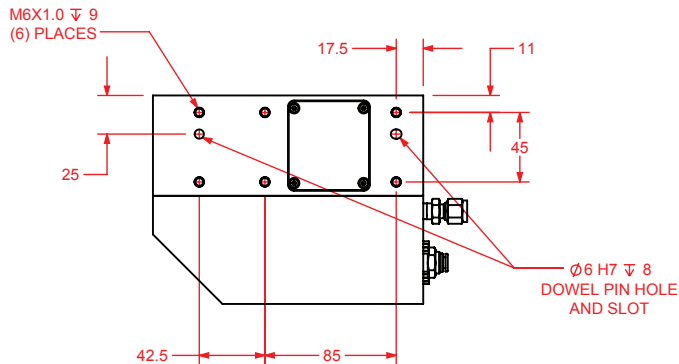

SIDE VIEW  
 (-MP) MOUNTING PLATE &  
 NO COOLING OPTIONS

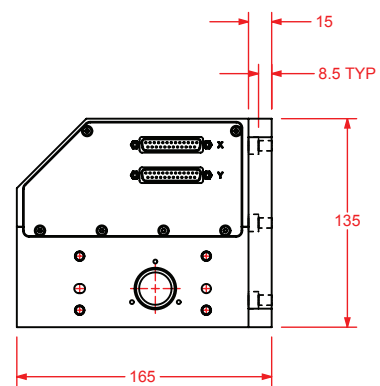

END VIEW  
 (-MP) MOUNTING PLATE &  
 NO COOLING OPTIONS

DIMENSIONS: MILLIMETERS

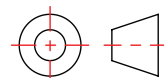

AGV20HP-BE2

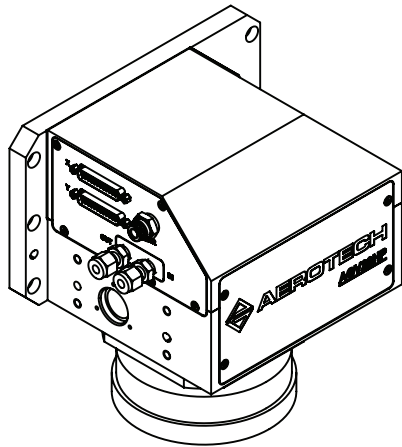
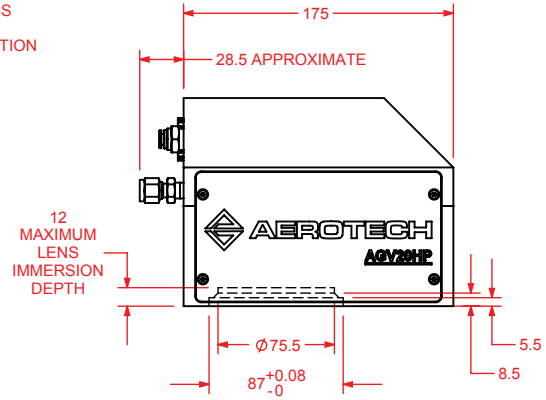
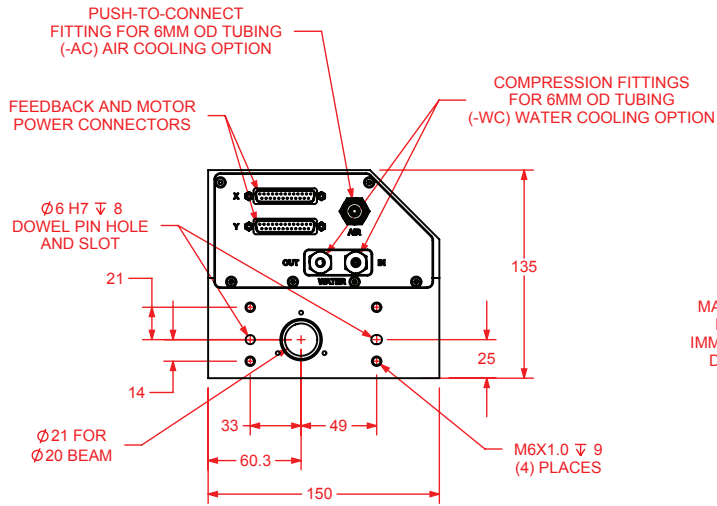

(-L7) F-THETA LENS  
 (-MP) MOUNTING PLATE OPTION  
 (-AC) AIR COOLING OPTION  
 (-WC) WATER COOLING OPTION

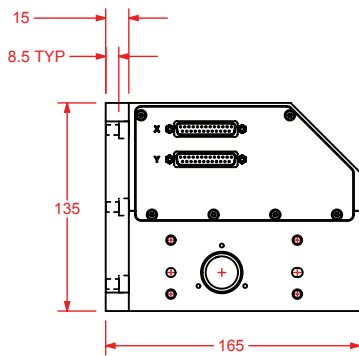
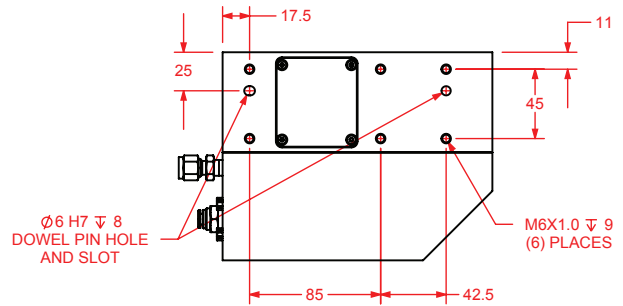
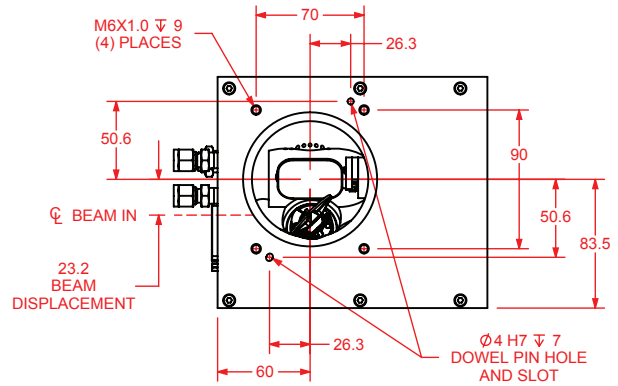

END VIEW  
 (-MP) MOUNTING PLATE &  
 NO COOLING OPTIONS

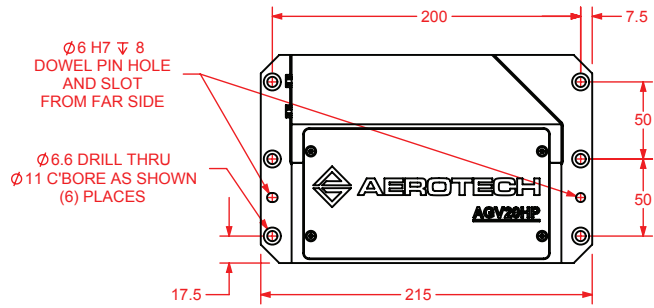

SIDE VIEW  
 (-MP) MOUNTING PLATE &  
 NO COOLING OPTIONS

DIMENSIONS: MILLIMETERS

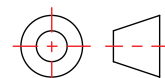

AGV20HPO-BE1

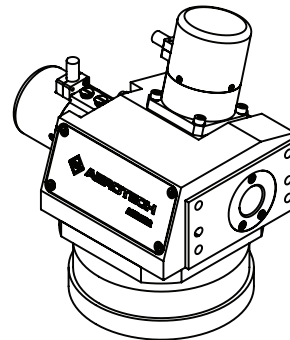
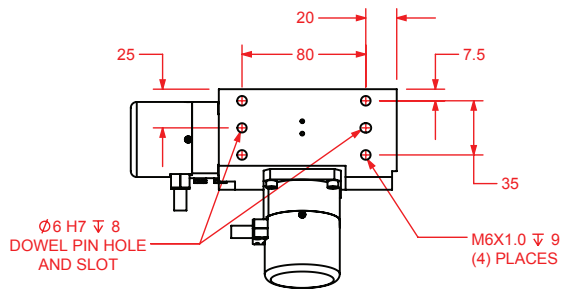
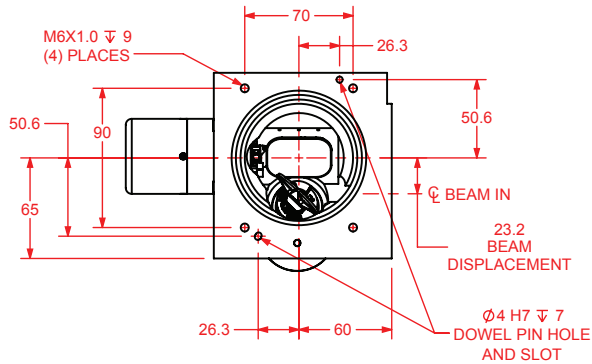
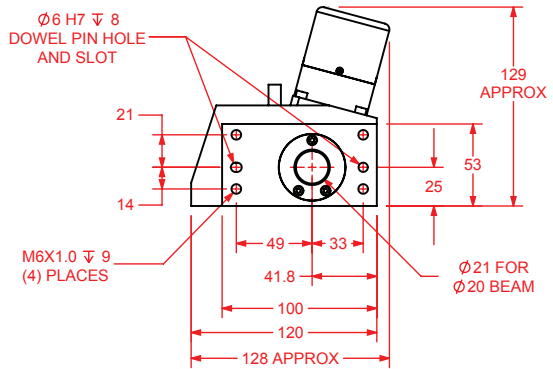
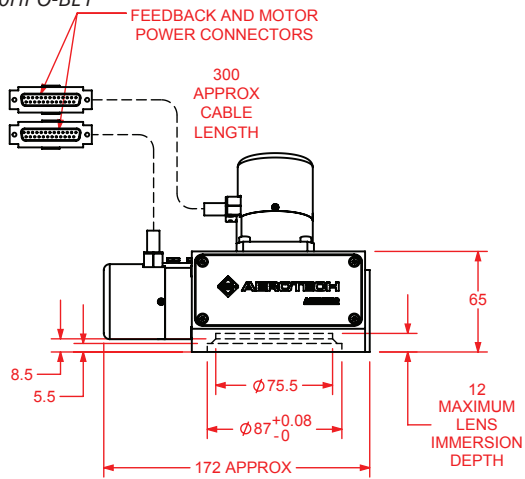

(-L7) F-THETA LENS  
NO COOLING OPTIONS

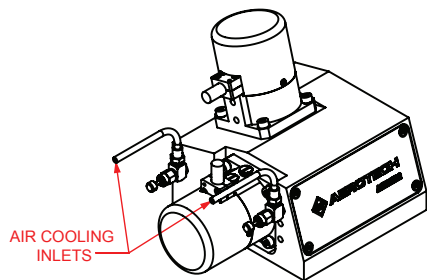

(-AC) AIR COOLING OPTION

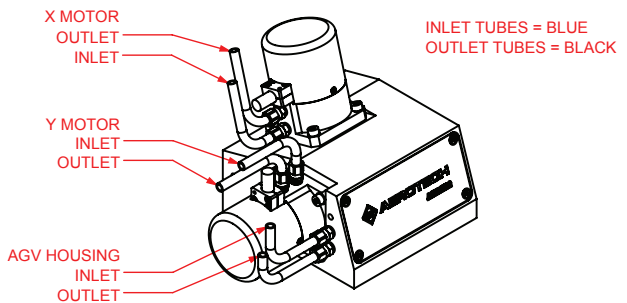

(-WC) WATER COOLING OPTION

DIMENSIONS: MILLIMETERS

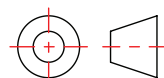

AGV20HPO-BE2

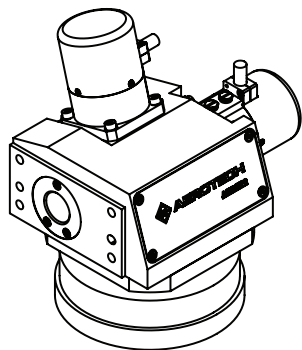
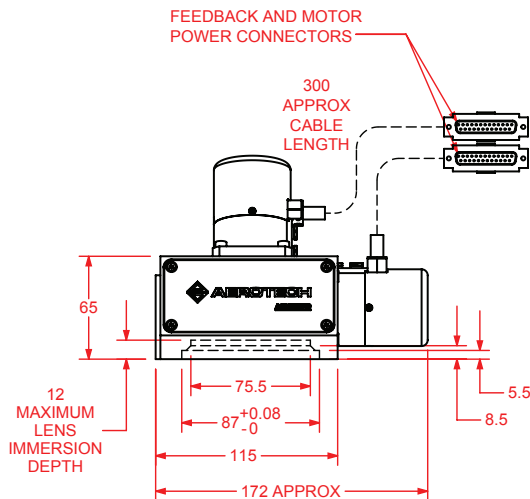
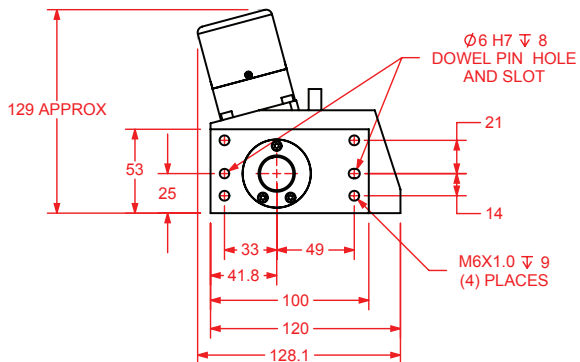

(-L7) F-THETA LENS  
NO COOLING OPTIONS

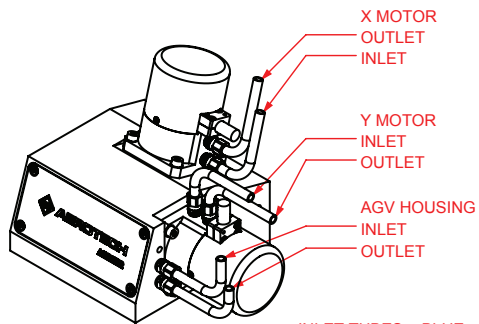
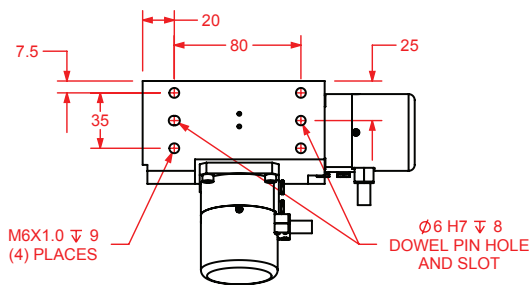
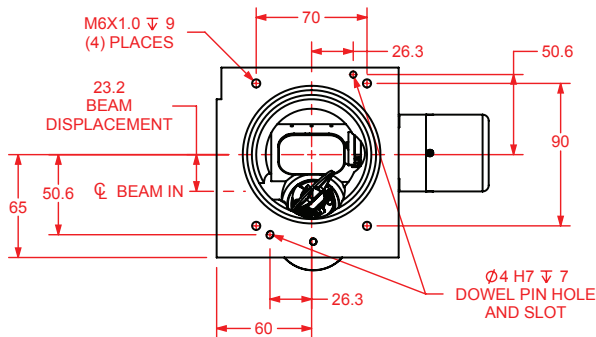

(-WC) WATER COOLING OPTION

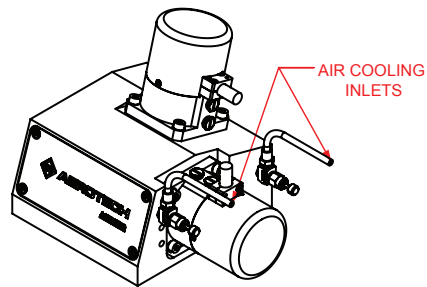

(-AC) AIR COOLING OPTION

DIMENSIONS: MILLIMETERS

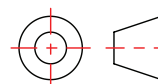

AGV30HP-BE1

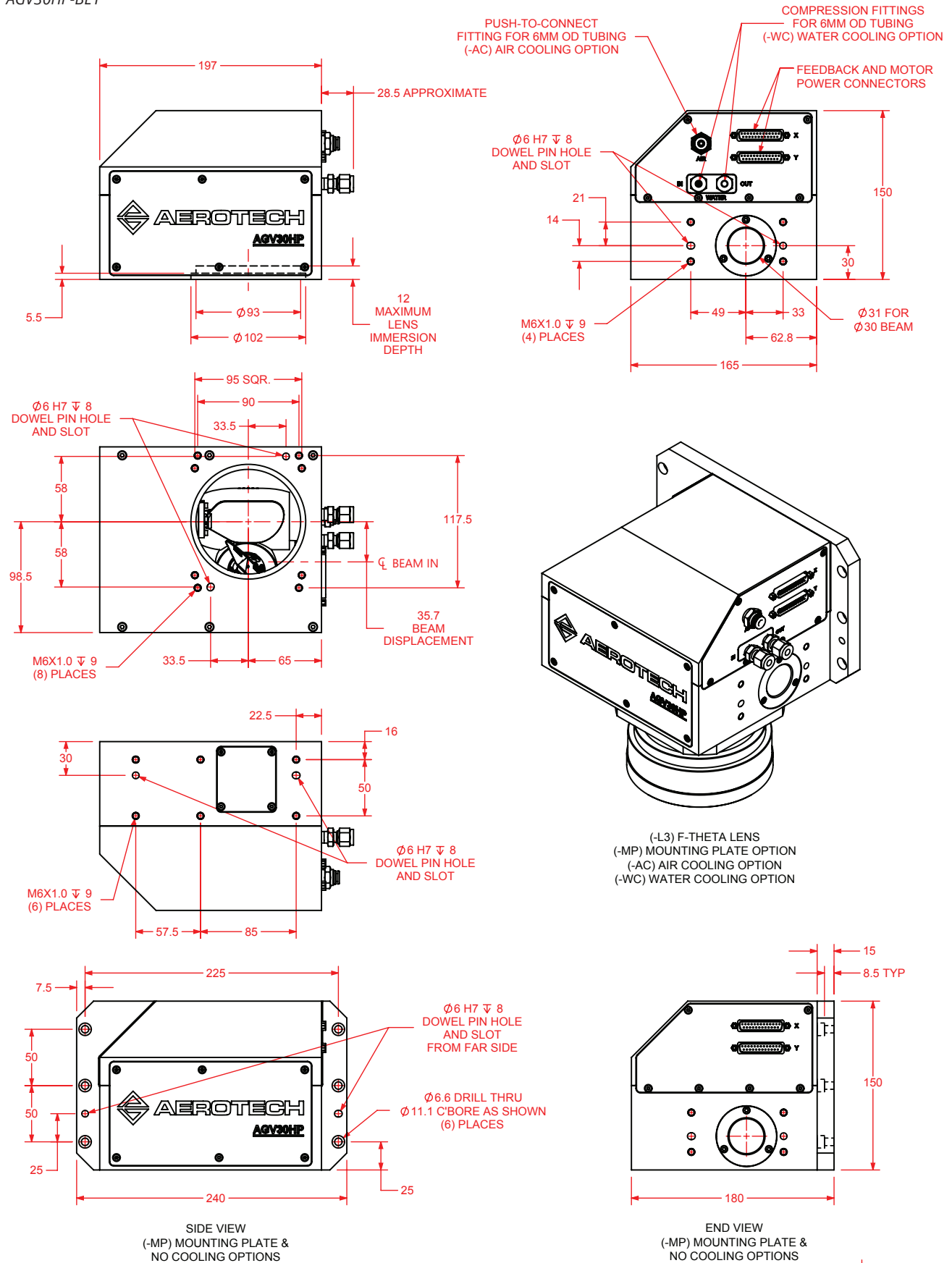

DIMENSIONS: MILLIMETERS

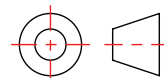

AGV30HPO-BE1

FEEDBACK AND MOTOR  
POWER CONNECTORS

300  
APPROX.  
CABLE  
LENGTH

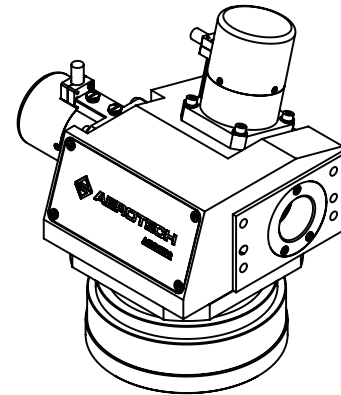
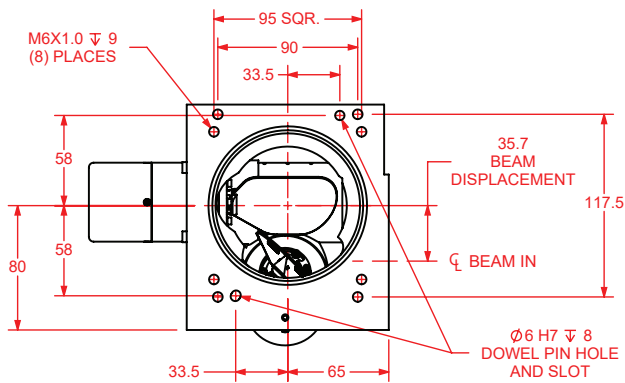
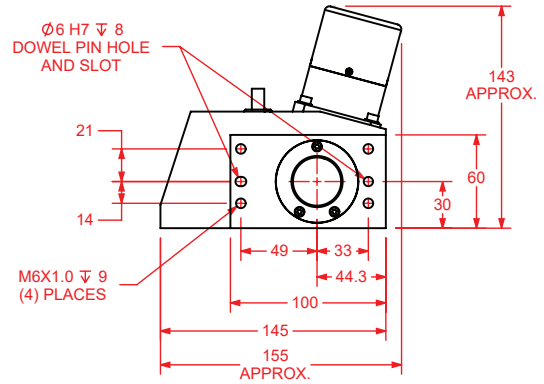
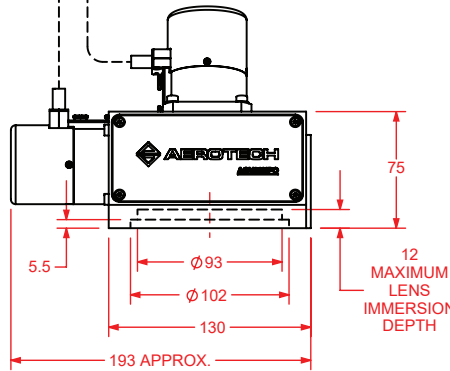

(-L3) F-THETA LENS  
NO COOLING OPTIONS

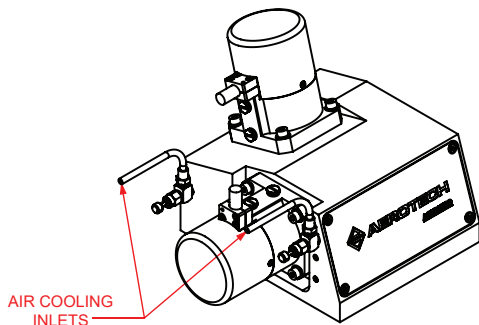
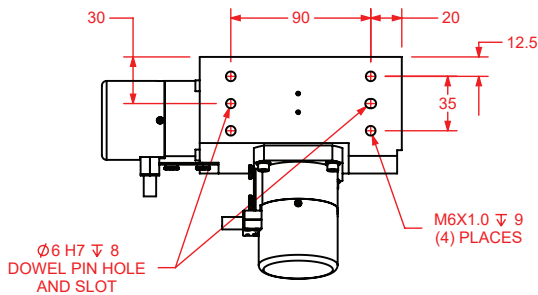

(-AC) AIR COOLING OPTION

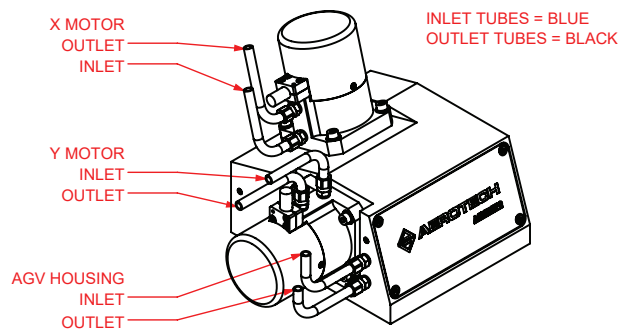

(-WC) WATER COOLING OPTION

DIMENSIONS: MILLIMETERS

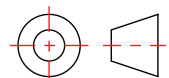



## AGV-HP(O) Series Galvanometer Scanner

---

AGV10HP(O)	2-axis galvanometer scanner with 10 mm diameter beam aperture and integral high precision feed back
AGV14HP(O)	2-axis galvanometer scanner with 14 mm diameter beam aperture and integral high-precision feed back
AGV20HP(O)	2-axis galvanometer scanner with 20 mm diameter beam aperture and integral high-precision feed back
AGV30HP(O)	2-axis galvanometer scanner with 30 mm diameter beam aperture and integral high-precision feed back

### Housing Type (Required)

---

-	Closed scanner housing (AGVxxHP)
O	Open scanner housing (AGVxxHPO)

### Beam Entry (Required)

---

-BE1	Right-side laser beam entry (standard)
-BE2	Left-side laser beam entry

Note: -BE2 is not available with AGV30HP or AGV30HPO.

### Wavelength of Mirror Coating (Required)

---

-W001	10.6 $\mu\text{m}$
-W002	Durable Silver (450 nm - 10.6 $\mu\text{m}$ )
-W003	1552 nm
-W004	1064 nm
-W005	1030 nm
-W006	532 nm
-W007	515 nm
-W008	355 nm
-W009	343 nm
-W012	9.3 $\mu\text{m}$

Note: Custom coatings available. Contact factory for details.

**F-Theta Lenses Available (Optional)<sup>(1, 2)</sup>**

---

-Lxx	See Table 1: F-Theta Lenses Available
------	---------------------------------------

**Mounting Plate (Optional)**

---

-MP	Mounting plate
-----	----------------

Note: -MP option is only available with closed scanner housing (AGVxxHP) models.

**Air Cooling (Optional)**

---

-AC	Air cooling
-----	-------------

**Water Cooling (Optional)**

---

-WC	Water cooling
-----	---------------

**Performance Grade (Required)**

---

-PL0	Standard performance grade
-PL9	Ultra performance grade

**Integration (Required)**

---

Aerotech offers both standard and custom integration services to help you get your system fully operational as quickly as possible. The following standard integration options are available for this system. Please consult Aerotech if you are unsure what level of integration is required, or if you desire custom integration support with your system.

-TAS	Integration - Test as system Testing, integration, and documentation of a group of components as a complete system that will be used together (ex: drive, controller, and stage). This includes parameter file generation, system tuning, and documentation of the system configuration.
-TAC	Integration - Test as components Testing and integration of individual items as discrete components that ship together. This is typically used for spare parts, replacement parts, or items that will not be used together. These components may or may not be part of a larger system.

**Lens Mounting Adapters (to be ordered as separate line item)**

---

LM10HP-XXX	Lens mount adapter for AGV10HP(O); standard versions support the lens configurations offered by Aerotech; custom versions available on request
LM14HP-XXX	Lens mount adapter for AGV14HP(O); standard versions support the lens configurations offered by Aerotech; custom versions available on request
LM20HP-XXX	Lens mount adapter for AGV20HP(O); standard versions support the lens configurations offered by Aerotech; custom versions available on request
LM30HP-XXX	Lens mount adapter for AGV30HP(O); standard versions support the lens configurations offered by Aerotech; custom versions available on request

Table 1: AGV F-Theta Lenses

	AGV10HP(O)	AGV14HP(O)	AGV20HP(O)	AGV30HP(O)
-L1	1552-100-T 55 mm sq. FOV	-	10600-100-T 35 mm sq. FOV	10600-255 100 mm sq. FOV
-L2	1552-163-T 90 mm sq. FOV	-	10600-160 75 mm sq. FOV	1064-200 65 mm sq. FOV <sup>4</sup>
-L3	1064-100 65 mm sq. FOV <sup>4</sup>	1552-100-T 45 mm sq. FOV	10600-255 160 mm sq. FOV	1064-255 150 mm sq. FOV <sup>4</sup>
-L4	1064-255 150 mm sq. FOV <sup>4</sup>	1552-163-T 90 mm sq. FOV	1064-100-T 40 mm sq. FOV	1064-500 230 mm sq. FOV <sup>4</sup>
-L5	1064-160 105 mm sq. FOV <sup>4</sup>	1064-100 35 mm sq. FOV <sup>4</sup>	1064-163 70 mm sq. FOV <sup>4</sup>	-
-L6	1064-163-T 90 mm sq. FOV	1064-100-T 60 mm sq. FOV <sup>4</sup>	1064-163-T 70 mm sq. FOV	-
-L7	1030-100-T 40 mm sq. FOV	1064-160 80 mm sq. FOV <sup>4</sup>	1064-255 150 mm sq. FOV <sup>4</sup>	-
-L8	1030-163-T 90 mm sq. FOV	1064-163-T 85 mm sq. FOV	532-255 145 mm sq. FOV <sup>4</sup>	-
-L9	532-100 55 mm sq. FOV <sup>4</sup>	1064-170 110 mm sq. FOV <sup>4</sup>	-	-
-L10	532-100-T 60 mm sq. FOV <sup>4</sup>	1030-100-T 30 mm sq. FOV	-	-
-L11	532-160 105 mm sq. FOV <sup>4</sup>	1030-163-T 90 mm sq. FOV	-	-
-L12	532-163-T 75 mm sq. FOV	532-100-T 60 mm sq. FOV <sup>4</sup>	-	-
-L13	515-100-T 40 mm sq. FOV	532-160 105 mm sq. FOV <sup>4</sup>	-	-
-L14	515-163-T 40 mm sq. FOV	532-163-T 75 mm sq. FOV	-	-
-L15	355-53-T 15 mm sq. FOV	532-170 100 mm sq. FOV <sup>4</sup>	-	-
-L16	355-100-T 50 mm sq. FOV	515-100-T 40 mm sq. FOV	-	-
-L17	355-160 90 mm sq. FOV	515-163-T 40 mm sq. FOV	-	-
-L18	355-163-T 80 mm sq. FOV	355-53-T 5 mm sq. FOV	-	-
-L19	355-255 140 mm sq. FOV	355-163-T 80 mm sq. FOV	-	-
-L20	-	355-255 140 mm sq. FOV	-	-
-L21	-	343-53-T 5 mm sq. FOV	-	-
-L22	-	343-163-T 70 mm sq. FOV	-	-
-L23	-	343-255 115 mm sq. FOV	-	-

Notes:

1. Lenses specified as XXX-YYY(-T), where "XXX" represents the wavelength in nanometers, "YYY" represents the focal length in millimeters, and the presence of "-T" indicates a telecentric design.
2. Input beam diameter is assumed to be equal to scan head entrance aperture at 1/e<sup>2</sup> Gaussian profile.
3. Reported field-of-view (FOV) sizes are approximate and may be subject to minor variation as a function of the application's laser and optical parameters. Contact factory for details.
4. Certain F-theta lenses are not recommended for use with short-pulse lasers (picosecond and femtosecond pulse durations). Contact factory for alternate lens options that are compatible with short-pulse lasers.
5. Custom lenses available. Contact factory for details.