

ABL1500Z Series

Air Bearing, Linear Motor Vertical Translation Stage

Designed for high-performance scanning and inspection

Active air preload on all air-bearing surfaces

Linear encoder feedback provides sub-nanometer resolution

High stiffness for heavy loads and excellent geometrical performance

Four models with travels from 50 to 200 mm

Integral counterbalance

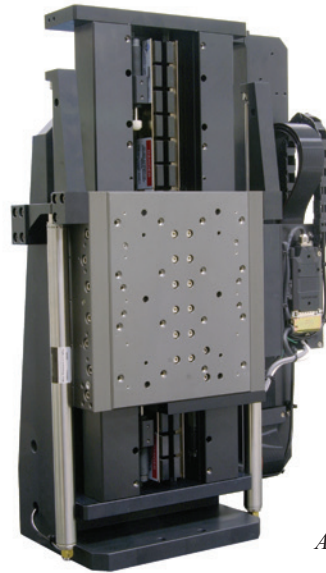

ABL1500Z

The ABL1500Z is a vertical lift version of the ABL1500 series air-bearing stage. The ABL1500Z is ideally suited for applications with large offset loads and where extreme accuracy is required.

Leading-edge manufacturing, particularly in the semiconductor and data storage industries, demands positioning tolerances beyond the capability of conventional ball-screw and mechanical-bearing positioning systems. The ABL1500Z, with its fully active preload, exceptionally high stiffness, and excellent geometric characteristics, was designed specifically to meet those demands.

Air-Bearing Design for High Dynamic Performance

The ABL1500Z incorporates an air-on-air preload on both the vertical and horizontal surfaces. The opposing thin-film pressure maintains the bearing nominal gap tolerance. This design, in addition to the large air-bearing surface that distributes the load over a large surface area, results in a stage with outstanding stiffness that is ideal for heavy or offset loading.

Aerotech's proprietary manufacturing techniques result in a stage with unsurpassed geometrical characteristics, which maximize performance by yielding superior pitch, roll, yaw, straightness, and flatness specifications.

Zero-Cogging Linear Motor Drive

The driving force behind this stage is Aerotech's BLMC

series brushless linear servomotor. The BLMC utilizes an ironlessforcer, which means there is zero cogging and no attractive forces, resulting in unsurpassed smoothness of motion.

No Maintenance

Our totally noncontact air bearing, noncontact linear motor drive, and noncontact feedback device ensure years of maintenance-free operation at the high performance levels expected of Aerotech equipment. Because there is no mechanical contact between moving elements, the ABL1500Z experiences no wear or reduction in performance over time. Service life is virtually unlimited and because there is no lubrication – only clean, dry gas – air bearings are ideal for cleanroom and medical applications.

Cable Management

We carefully optimize the cable bend radius to ensure years of trouble-free operation. In the unlikely event of failure, Aerotech's modular design makes cable replacement quick and easy with minimal downtime.

We include all customer-required cables, air hoses, etc. in our CMS bundle to facilitate integration into the final system. Both ends are fully connectorized for simple integration into the customer's machine.

ABL1500Z Series SPECIFICATIONS

Mechanical Specifications			ABL1500Z-050	ABL1500Z-100	ABL1500Z-150	ABL1500Z-200
Travel			50 mm (2 in)	100 mm (4 in)	150 mm (6 in)	200 mm (8 in)
Accuracy ⁽¹⁾	E1	Calibrated	±0.3 µm (±12 µin)	±0.3 µm (±12 µin)	±0.4 µm (±12 µin)	±0.5 µm (±20 µin)
		Standard	±2.0 µm (±80 µin)	±3.0 µm (±120 µin)	±5.0 µm (±160 µin)	±8.0 µm (±320 µin)
	E3	HALAR	±0.2 µm (±8 µin)	±0.2 µm (±8 µin)	±0.3 µm (±12 µin)	±0.5 µm (±20 µin)
		Calibrated	±1.5 µm (±60 µin)	±2.5 µm (±100 µin)	±4.0 µm (±160 µin)	±6.0 µm (±240 µin)
Repeatability (Bi-Directional) ⁽¹⁾	E1	±0.1 µm (±4 µin)		±0.15 µm (±6 µin)	±0.2 µm (±8 µin)	
	E3	±0.1 µm (±4 µin)		±0.15 µm (±6 µin)	±0.2 µm (±8 µin)	
Straightness ⁽¹⁾			±0.4 µm (±16 µin)	±0.6 µm (±24 µin)	±0.8 µm (±32 µin)	±1.0 µm (±40 µin)
Flatness ⁽¹⁾			±0.4 µm (±16 µin)	±0.6 µm (±24 µin)	±0.8 µm (±32 µin)	±1.0 µm (±40 µin)
Pitch			±1 arc sec	±1.5 arc sec	±2 arc sec	±2.5 arc sec
Roll			±1 arc sec	±1.5 arc sec	±2 arc sec	±2.5 arc sec
Yaw			±1 arc sec	±1.5 arc sec	±2 arc sec	±2.5 arc sec
Maximum Speed			300 mm/s			
Maximum Acceleration			2 g - 20 m/s ² - 768 in/s ² (No Load)			
Maximum Force (Continuous)			93.6 N (21.0 lb)			
Load Capacity ⁽²⁾			15 kg (33.1 lb)			
Operating Pressure			80 psi (5.5 bar) ±5 psig (0.3 bar)			
Air Consumption			Stage: 24-30 slpm @ 551 kPa; Counterbalance: 60 slpm maximum			
Moving Mass (No Load)			5.9 kg (13.0 lb)			
Stage Mass			23.8 kg (52.5 lb)	26.6 kg (58.6 lb)	28.5 kg (62.8 lb)	30.5 kg (67.2 lb)
Material			Hardcoat Anodized Aluminum			
MTBF (Mean Time Between Failure)			20,000 Hours			

Notes:

1. Certified with each stage.
2. Axis orientation for on-axis loading is listed.
3. Specifications are for single-axis systems measured 25 mm above the tabletop. Performance of multi-axis systems is payload and workpoint dependent. Consult factory for multi-axis or non-standard applications.
4. To protect air bearing against under-pressure, an in-line pressure switch tied to the motion controller/amplifier ESTOP input is recommended.
5. Air supply must be clean, dry to 0° F dewpoint and filtered to 0.25 µm or better; recommend nitrogen at 99.9% purity.
6. Maximum upper axis length is 200 mm when mounting the ABL1500 in an XY configuration.

Electrical Specifications	
Drive System	Brushless Linear Servomotor
Feedback	Noncontact Linear Encoder (see signal period options on Order Information page)
Maximum Bus Voltage	up to 80 VDC
Limit Switches	5 V, Normally Open
Home Switch	Near Center

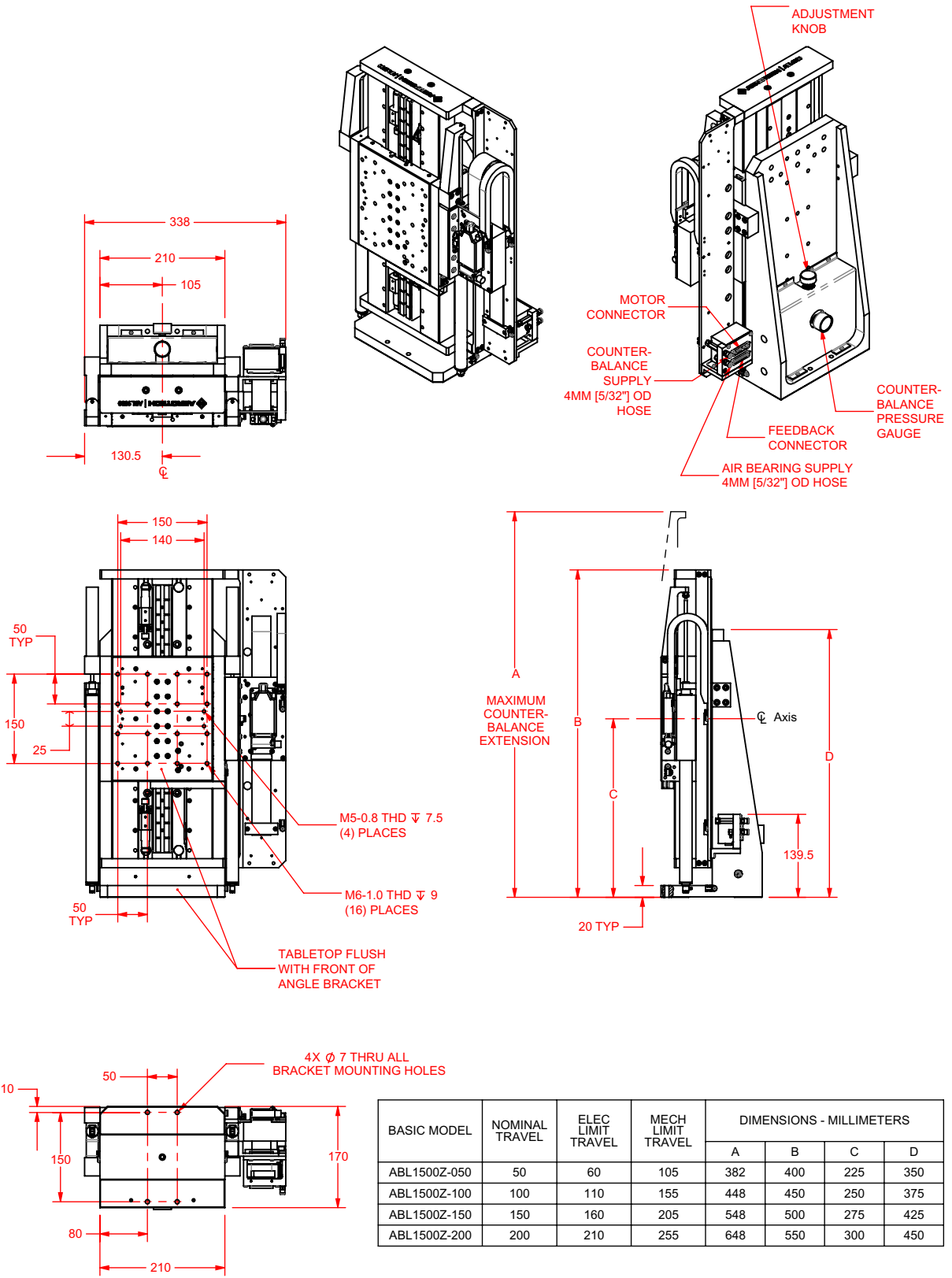

DIMENSIONS: MILLIMETERS

ABL1500Z Series ORDERING INFORMATION

Travel (Required)

-050	50 mm travel
-100	100 mm travel
-150	150 mm travel
-200	200 mm travel

Feedback (Required)

-E1	Incremental linear encoder, 1 Vpp amplified sine output
-E2	Incremental linear encoder, 0.1 μ m TTL line driver output
-E3	High-accuracy incremental linear encoder, 1 Vpp amplified sine output

Cable Management (Required)

-CMS1	Single axis cable management system
-CMS2	Cable management system for ZT assembly

Metrology (Required)

-PL1	Metrology, uncalibrated with performance plots
-PL2	Metrology, calibrated (HALAR) with performance plots

Integration (Required)

Aerotech offers both standard and custom integration services to help you get your system fully operational as quickly as possible. The following standard integration options are available for this system. Please consult Aerotech if you are unsure what level of integration is required, or if you desire custom integration support with your system.

-TAS	Integration - Test as system Testing, integration, and documentation of a group of components as a complete system that will be used together (ex: drive, controller, and stage). This includes parameter file generation, system tuning, and documentation of the system configuration.
-TAC	Integration - Test as components Testing and integration of individual items as discrete components that ship together. This is typically used for spare parts, replacement parts, or items that will not be used together. These components may or may not be part of a larger system.

Accessories (to be ordered as a separate line item)

ALIGN-NPA	Non-precision XY assembly
ALIGN-PA10	XY assembly; 10 arc sec orthogonality. Alignment to within 7 microns orthogonality for short travel stages.
ALIGN-PA5	XY assembly; 5 arc sec orthogonality. Alignment to within 3 microns orthogonality for short travel stages.
ABF	Air-bearing filtration kit