



BM/BMS Series Brushless Rotary Motor

HARDWARE MANUAL

Revision 3.01



GLOBAL TECHNICAL SUPPORT

Go to the [Global Technical Support Portal](#) for information and support about your Aerotech, Inc. products. The website supplies software, product manuals, Help files, training schedules, and PC-to-PC remote technical support. If necessary, you can complete Product Return (RMA) forms and get information about repairs and spare or replacement parts. To get help immediately, contact a service office or your sales representative. Include your customer order number in your email or have it available before you call.

This manual contains proprietary information and may not be reproduced, disclosed, or used in whole or in part without the express written permission of Aerotech, Inc. Product names mentioned herein are used for identification purposes only and may be trademarks of their respective companies.

Copyright © 1996-2025, Aerotech, Inc. | All rights reserved.

See the latest version of Aerotech's [Terms of Use](#), [Privacy Policy](#), and [Cookie Policy](#) online at aerotech.com.



Table of Contents

BM/BMS Series Brushless Rotary Motor	1
Table of Contents	3
List of Figures	4
List of Tables	5
EU Declaration of Conformity	7
UKCA Declaration of Conformity	8
Safety Procedures and Warnings	9
Installation and Operation	10
Electrical Warnings	12
Motor-Related Warnings	13
Pinch Points	14
Handling and Storage	15
Chapter 1: Overview	17
1.1. Motor Specifications	21
1.2. Dimensions	31
1.3. Environmental Specifications	38
1.4. Vacuum Operation	39
Chapter 2: Assembly and Installation	41
2.1. Connector Pinout	41
2.1.1. Motor Connectors	42
2.1.2. Feedback Connectors	44
2.2. External Motor Wiring	48
2.2.1. Motor Power Conductors	48
2.2.2. Protective Ground	48
2.2.3. Over-Current Protection	48
2.2.4. Hall-Effect Device and Thermistor Wiring	49
2.2.5. Wiring Guidelines	49
2.2.6. Thermal Protective Device [BMS Motors Only]	50
2.3. Hall-Effect Operation and Motor Phasing	52
2.4. Motor Heating	56
Chapter 3: Maintenance	57
Appendix A: Warranty and Field Service	59
Appendix B: Revision History	61
Index	63

List of Figures

Figure 1-1: Torque Speed Curves (BM24, BM75, and BM130)	22
Figure 1-2: Torque Speed Curves (BM200, BM250, and BM500)	24
Figure 1-3: Torque Speed Curves (BM800 and BM1400)	26
Figure 1-4: Torque Speed Curves (BMS35, BMS60, and BMS100)	28
Figure 1-5: Torque Speed Curves (BMS280 and BMS465)	30
Figure 1-6: BM24 Model Dimensions (NEMA 17)	31
Figure 1-7: BM75, BM130, BM200 Model Dimensions (NEMA 23)	32
Figure 1-8: BM250, BM500 Model Dimensions (NEMA 34)	33
Figure 1-9: BM800, BM1400 Model Dimensions (NEMA 42)	34
Figure 1-10: BMS35 Model Dimensions (NEMA 17)	35
Figure 1-11: BMS60 and BMS100 Model Dimensions (NEMA 23)	36
Figure 1-12: BMS280 and BMS465 Model Dimensions (NEMA 34)	37
Figure 2-1: Thermal Sensor Resistance as a Function of Temperature	50
Figure 2-2: Typical Thermistor Interface Circuit	51
Figure 2-3: Hall Effect and Motor Phasing	52
Figure 2-4: Test Setup Configuration	53
Figure 2-5: Motor Lead Phasing with Oscilloscope	54
Figure 2-6: Hall Phasing with Oscilloscope	55
Figure 2-7: Operating Regions Example	56

List of Tables

Table 1-1: BM Motor Options	17
Table 1-2: BMS Motor Options	19
Table 1-3: BM24, BM75, and BM130 Motor Specifications	21
Table 1-4: BM200, BM250, and BM500 Motor Specifications	23
Table 1-5: BM800 and BM1400 Motor Specifications	25
Table 1-6: BMS35, BMS60, and BMS100 Motor Specifications	27
Table 1-7: BMS280 and BMS465 Motor Specifications	29
Table 1-8: Environmental Specifications	38
Table 2-1: Motor Connector Options	41
Table 2-2: Feedback Connector Options	41
Table 2-3: Limit Connector Options	41
Table 2-4: Motor Power Connector Pinout (-MS Option)	42
Table 2-5: Mating Connector Part Numbers for the Motor Power Connector (-MS Option)	42
Table 2-6: Motor Connector Pinout (-D25 Option)	42
Table 2-7: Mating Connector Part Numbers for the Motor Power Connector (-D25 Option)	42
Table 2-8: Motor Power Flying Leads Pinout (-D25-FLB Option)	43
Table 2-9: Motor Power Terminal Block Pinout (-D25-4TS Option)	43
Table 2-10: Motor Connector Pinout (-D25-5D Option)	43
Table 2-11: Mating Connector Part Numbers for the -D25-5D Option Motor Power Connector	43
Table 2-12: Feedback Connector Pinout (-MS Option)	44
Table 2-13: Mating Connector Part Numbers for the -MS Option Feedback Connector	44
Table 2-14: Feedback Connector Pinout (without Limits, -D25 Option)	45
Table 2-15: Mating Connector Part Numbers for the -D25 Option Feedback Connector	45
Table 2-16: Feedback Connector Pinout (with Limits, -D25-9D, -9D-CMS, -5D, -FLB, -4TS)	46
Table 2-17: Mating Connector Part Numbers for the -D25-XX Feedback Connector	46
Table 2-18: Limit Connector Pinout (-D25-9D,-9D-CMS, -5D, -FLB, -4TS)	47
Table 2-19: Mating Connector Part Numbers for the Limit Connector	47

This page intentionally left blank.

EU Declaration of Conformity

Manufacturer Aerotech, Inc.
Address 101 Zeta Drive
 Pittsburgh, PA 15238-2811
 USA



Declares that the product:

Product Standard BM and BMS motors (excluding VAC6 versions)
Model/Types BM75, BM130, BM200, BM250, BM500, BM800, BM1400, BMS35, BMS60,
 BMS100, BMS280, BMS465

To which this declaration relates, meets the essential health and safety requirements and is in conformity with the relevant EU Directives listed below:

2014/35/EU	Low Voltage Directive
EU 2015/863	Directive, Restricted Substances (RoHS 3)

Using the relevant section of the following EU Standards and other normative documents:

IEC 60034-1:2010	Rotating electrical machines
IEC 61010-1:2010	Safety requirements for electrical equipment for measurement, control, and laboratory use

NOTE: Safe operation of the motor requires over speed and over current protection. This could be done by the connected controller / amplifier combination.

Authorized Representative:

Managing Director
 Aerotech GmbH
 Gustav-Weißkopf-Str. 18
 90768 Fürth
 Germany

 Jochen Jäger

Engineer Verifying Compliance:

Aerotech, Inc.
 101 Zeta Drive
 Pittsburgh, PA 15238-2811
 USA

 Matt Maurer

Date: 2/18/2025

UKCA Declaration of Conformity

Manufacturer Aerotech, Inc.
Address 101 Zeta Drive
 Pittsburgh, PA 15238-2811
 USA



Declares that the product:

Product Standard BM and BMS motors (excluding VAC6 versions)
Model/Types BM75, BM130, BM200, BM250, BM500, BM800, BM1400, BMS35, BMS60, BMS100, BMS280, BMS465

To which this declaration relates, meets the essential health and safety requirements and is in conformity with the relevant UK Legislation listed below:

Electrical Equipment (Safety) Regulations 2016
 Hazardous Substances in Electrical and Electronic Equipment Regulations 2012

Using the relevant section of the following UK Designated Standards and other normative documents when installed in accordance with the installation instructions supplied by the manufacturer.

IEC 60034-1:2010 Rotating electrical machines
 IEC 61010-1:2010 Safety requirements for electrical equipment for measurement, control, and laboratory use

NOTE: Safe operation of the motor requires over speed and over current protection. This could be done by the connected controller / amplifier combination.

Authorized Representative:

Managing Director
 Aerotech Ltd
 The Old Brick Kiln
 Ramsdell, Tadley
 Hampshire RG26 5PR
 UK



 Simon Smith

Engineer Verifying Compliance:

Aerotech, Inc.
 101 Zeta Drive
 Pittsburgh, PA 15238-2811
 USA
 Date: 2/18/2025



 Matt Maurer

Safety Procedures and Warnings



IMPORTANT: This manual tells you how to carefully and correctly use and operate the motor.

- Read all parts of this manual before you install or operate the motor or before you do maintenance to your system.
- To prevent injury to you and damage to the equipment, obey the precautions in this manual.
- All specifications and illustrations are for reference only and were complete and accurate as of the release of this manual. To find the newest information about this product, refer to www.aerotech.com.

If you do not understand the information in this manual, contact Aerotech Global Technical Support.



IMPORTANT: This product has been designed for light industrial manufacturing or laboratory environments. If the product is used in a manner not specified by the manufacturer:

- The protection provided by the equipment could be impaired.
- The life expectancy of the product could be decreased.

Safety notes and symbols are placed throughout this manual to warn you of the potential risks at the moment of the safety note or if you fail to obey the safety note.



Shock/Electrocution Hazard



Pinch, Shear, or Crush Hazard



General/Conditional Awareness



Rotational Machinery Hazard



Hot Surface Hazard



Pinch/Entanglement Hazard



Magnetic Field Hazard



Trip Hazard



Heavy, Bulky Lifting Hazard



Appropriate Equipment Required



Pressure/Explosive Atmosphere Hazard



Electrostatic Discharge Hazard

A blue circle symbol is an action or tip that you should obey. Some examples include:



General tip



Read the manual/section



Wear personal protective equipment (PPE): Safety Glasses



If applicable, do not lift unassisted



Wear personal protective equipment (PPE): Gloves



Wear personal protective equipment (PPE): Hearing Protection

Installation and Operation

To decrease the risk of damage to the equipment, you must obey the precautions that follow.



IMPORTANT: Aerotech motors are meant to be part of a drive package that consists of an amplifier and a controller. The motor relies on the drive package for fault protection. Do not use these motors in any other way.

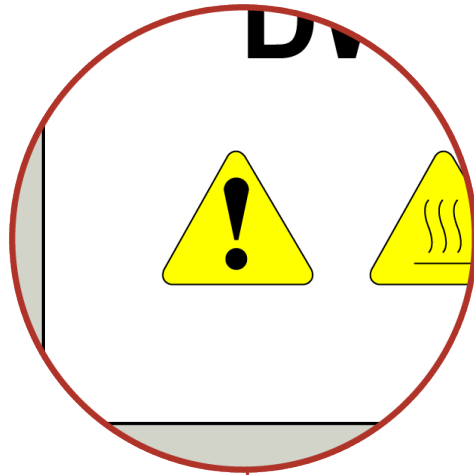

This symbol on the motor label means that you must read this manual in its entirety to understand any potential dangers and what actions you will have to take to avoid them.

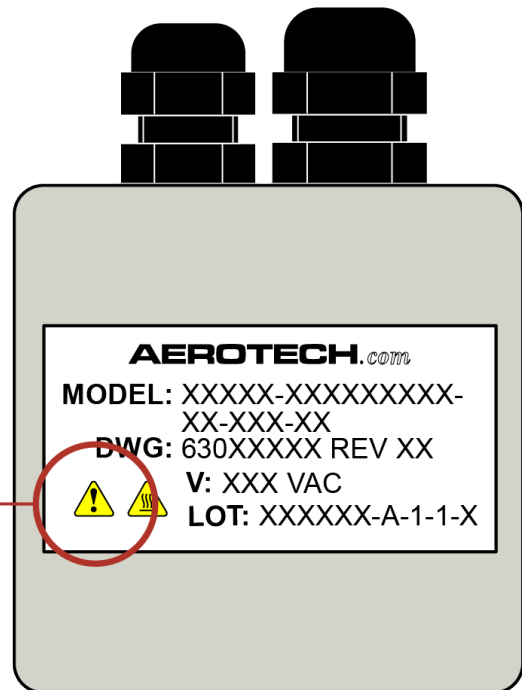

Rear View

DANGER: General Hazard Warning!



This product can produce high forces and move at velocities that could cause injury. The user is responsible for its safe operation. The following general equation is provided to assist with risk assessments in regards to contact and pinch points:

$$Pressure_{Max} \left[\frac{N}{mm^2} \right] = \frac{Force_{Peak} [N]}{Area_{Contact} [mm^2]}$$

**WARNING: General Hazard Warning!**

- Only trained operators should operate this equipment.
- All service and maintenance must be done by approved personnel.
- Use this product only in environments and operating conditions that are approved in this manual.
- Never install or operate equipment that appears to be damaged.
- For BMS motors: the motor over-temperature sensor must be monitored by the drive. Use it to shut down the drive if the motor overheats.
- For BM motors: it is the responsibility of the user to monitor the motor temperature to make sure that the motor does not overheat.
- Make sure that the product is securely mounted before you operate it.
- Use care when you move the motor or you could negatively affect the performance of it.

**WARNING: Trip Hazard!**

Route, house, and secure all cables, duct work, air, or water lines. Failure to do so could introduce trip hazards around the system that could result in physical injury or could damage the equipment.

Electrical Warnings

To decrease the risk of electrical shock, injury, death, and damage to the equipment, obey the precautions that follow.



DANGER: Electrical Shock Hazard!

- Motor phase voltage levels could be hazardous live.
- Personnel are protected from hazardous voltages unless electrical interconnections, protective bonding (safety ground), or motor enclosures are compromised.
- Do not connect or disconnect motor interconnections while connected to a live electrical power source.
- Before you set up or do maintenance, disconnect electrical power.
- Make sure that the motor frame is safety grounded with a conductor equal in size to the phase conductors.
- The drive must contain a properly-sized fuse, matched to the motor cable wire size.
- It is the responsibility of the End User/System Integrator to make sure that motors are properly connected and grounded per Engineering Standards and applicable safety requirements.
- It is the responsibility of the End User/System Integrator to configure the system drive or controller within the Aerotech motor electrical and mechanical specifications.

Motor-Related Warnings

Aerotech motors are capable of producing high forces and velocities. Obey all warnings and all applicable codes and standards when you use or operate a stage or system that incorporates Aerotech motors.

DANGER: Mechanical Hazard!



Personnel must be made aware of the mechanical hazards during set up or when you do service to the motor.

- Unintentional manual movement into the stage "end-of-travel" stops, could damage the stage or undo precision alignments.
- Motor movement could create pinch points, entanglement hazards, or rotational mechanical hazards.
- Uncouple or otherwise prevent motion of motor-coupled machinery when you do service to the equipment.

DANGER: Hot Surface Hazard!



- The motor frame temperature could exceed 70°C in some applications.
- Do not touch the motor frame while it is in operation.
- Wait until the motor has cooled before you touch it.

DANGER: Risk of Explosive Atmosphere!



- Standard Aerotech motors are not rated for applications with explosive atmospheres such as airborne dust or combustible vapors.
- Do not operate motors outside of Aerotech environmental specifications.

DANGER: Magnetic Field Hazard!



Aerotech motors contain magnets which can present a Magnetic Field Hazard.

- Do not disassemble a motor under any circumstances.
- Strong magnetic fields could interfere with external/internal medical devices.
- Strong magnetic fields could present mechanical hazards such as pinch points.

Pinch Points

A pinch point is a mechanical hazard that can occur when there are exposed parts of the motor, stage, or system that can move. For example, the travel of a stage tabletop could expose the user to a pinch point between the tabletop and the stage housing. The images that follow will show you typical external and internal pinch point locations.

DANGER: Mechanical Hazard!



- System travel can cause crush, shear, or pinch injuries.
- Only trained operators should operate this equipment.
- Do not put yourself in the travel path of machinery.
- Restrict access to all motor parts
 - when the system moves under power (during normal operation, for example).
 - when the system is moved manually (during the installation process or when you do maintenance, for example).
- Motors are capable of very high speeds and acceleration rates.

Figure 1: Typical Pinch Point Locations

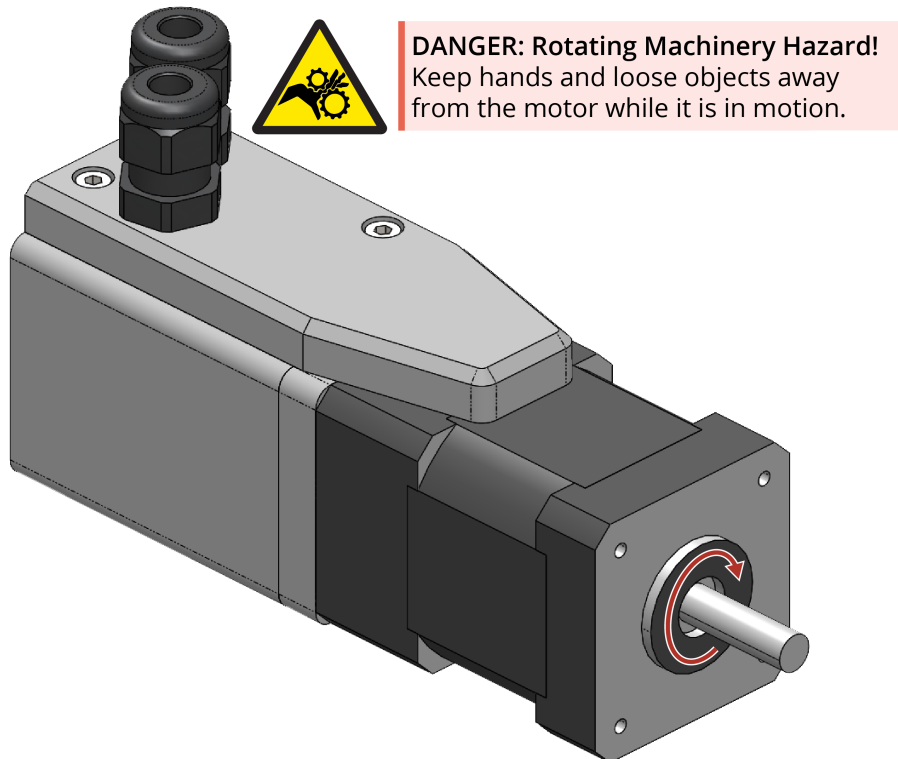

Handling and Storage



IMPORTANT: It is the responsibility of the customer to safely and carefully lift and move the motor.

- Be careful when you move or transport the motor.
- Retain the shipping materials for future use.
- Transport or store the motor in its protective packaging.



WARNING: Electrostatic Discharge (ESD) Sensitive Components!

Wear an ESD wrist strap when you handle, install, or do service to the system assembly.

Failure to observe the correct ESD practices could cause ESD damage to stage electronics, system drives, and/or power supplies.

Inspect the shipping container for any evidence of shipping damage. If any damage exists, notify the shipping carrier immediately.

Remove the packing list from the shipping container. Make sure that all the items specified on the packing list are contained within the package.

The documentation for the motor is on the included installation device. The documents include manuals, interconnection drawings, and other system documentation. Save this information for future reference.

Each motor has a label listing the system part number and serial number. These numbers contain information necessary for maintenance or system hardware and software updates. Locate this label and record the information for later reference.

Unpacking and Handling

It is the responsibility of the customer to safely and carefully lift and move the motor.



IMPORTANT: All electronic equipment and instrumentation is wrapped in antistatic material and packaged with desiccant. Ensure that the antistatic material is not damaged during unpacking.



DANGER: Lifting Hazard! Use care when you move the motor or you could negatively affect the performance of it.

- Use the correct lifting techniques, mechanical assistance, or additional help to lift or move this product.
- Do not use the cables or the connectors to lift or move this product.
- Make sure that all moving parts are secure before you move the motor. Unsecured moving parts could shift and cause injury or damage to the equipment.
- If the motor is heavy, a single person lift could cause injury. Use assistance when you lift or move it.
 - Refer to [Section 1.2. Dimensions](#) for dimensions
 - Refer to [Section 1.1. Motor Specifications](#) for weight specifications.

Carefully remove the motor from its protective shipping container.

- Lift this product only by the base.
- Use a cart, dolly, or similar device to move the motor to a new location.

Gently set the motor on a smooth, flat, and clean surface. Use compressed nitrogen or clean, dry, oil-free air to remove any dust or debris that has collected during shipping.

Before you operate the motor, let it stabilize at room temperature for at least 12 hours. This will ensure that all of the alignments, preloads, and tolerances are the same as they were when they were tested at Aerotech.

Storage

Store the motor in the original shipping container. If the original packaging included ESD protective packaging, make sure to store the motor in it. The storage location must be dry, free of dust, free of vibrations, and flat.

Refer to [Section 1.3. Environmental Specifications](#)

Chapter 1: Overview

Table 1-1: BM Motor Options

Brushless Rotary Servomotors	
BM24	NEMA 17 brushless servomotor
BM75	NEMA 23 brushless servomotor
BM130	NEMA 23 brushless servomotor
BM200	NEMA 23 brushless servomotor
BM250	NEMA 34 brushless servomotor
BM500	NEMA 34 brushless servomotor
BM800	NEMA 42 brushless servomotor
BM1400	NEMA 42 brushless servomotor
Connectors (Required)	
-MS	Integral cables with military-style feedback and motor connectors; compatible with: BM75, BM130, BM200, BM250, BM500, BM900, BM1400
-D25	Integral cables with D-style 25-pin feedback and D-style 4-pin motor connectors; compatible with: BM24, BM75, BM130, BM200
-D25-9D	Integral cables with D-style 25-pin feedback, D-style 4-pin motor, and D-style 9-pin limit connectors; compatible with: BM75, BM130, BM200
-D25-FLB	Integral cables with D-style 25-pin feedback connector, flying leads for the motor, and a D-style 9-pin limit connector; compatible with: BM75, BM130, BM200
-D25-5DU	Integral cables with D-style 25-pin feedback, D-style 5-pin motor, and D-style 9-pin limit connectors; compatible with: BM75, BM130, BM200
-D25-9D-CMS	Integral cables with D-style 25-pin feedback, D-style 4-pin motor, and D-style 9-pin limit connectors and a cable management system; compatible with: BM75, BM130, BM200
-D25-4TS	Integral cables with D-style 25-pin feedback, terminal block 4-pin motor, and D-style 9-pin limit connectors; compatible with: BM75, BM130, BM200
Feedback (Required)	
-E1000H	1000 lines/rev TTL incremental encoder with Hall tracks; compatible with: BM75, BM130, BM200, BM250, BM500, BM900, BM1400
-E2000H	2000 lines/rev TTL incremental encoder with Hall tracks; compatible with: BM75, BM130, BM200, BM250, BM500, BM900, BM1400
-E2500H	2500 lines/rev TTL incremental encoder with Hall tracks
-E5000H	5000 lines/rev TTL incremental encoder with Hall tracks; compatible with: BM75, BM130, BM200, BM250, BM500, BM900, BM1400
-E1000ASH	1000 lines/rev 1 Vpp incremental encoder with Hall tracks

Brake (Optional)	
-BK	Holding brake
Cable Type (Optional)	
-HF	Hi-Flex life cable; compatible with: BM75, BM130, BM200
Cable Length (Optional)	
-xx	Cable length from motor to connectors in decimeters; 3.8 dm is the default with a 50 dm maximum; compatible with: BM75, BM130, BM200
Shaft Seal (Optional)	
-NS	Nitrile front shaft seal; compatible with: BM250, BM500, BM800, BM1400
Vacuum Preparation (Optional)	
-VAC6	Vacuum preparation to 10^{-6} Torr
Accessories	
MC-HPD25-M	High-power D-style motor mating connector
MC-DB25-F	D-style 25-pin motor and feedback mating connector
MCM-3	Military style motor power mating connector; compatible with: BM75, BM130, BM200, BM250, BM500, BM800, BM1400
MCF-3	Military style feedback mating connector

Table 1-2: BMS Motor Options

BMS Series Rotary Servo Motors	
BMS35	NEMA 17 brushless servomotor
BMS60	NEMA 23 brushless servomotor
BMS100	NEMA 23 brushless servomotor
BMS280	NEMA 34 brushless servomotor
BMS465	NEMA 34 brushless servomotor
Winding Options	
-A	Standard winding
NOTE: Alternate winding options are available. Contact Aerotech for more information.	
Connectors	
-MS	Integral cables with military-style feedback and motor connectors; compatible with: BMS60, BMS100, BMS280, BMS465
-D25	Integral cables with D-style 25-pin feedback and D-style 4-pin motor connectors; compatible with: BMS35, BMS60, BMS100
-D25-9D	Integral cables with D-style 25-pin feedback, D-style 4-pin motor, and D-style 9-pin limit connectors; compatible with: BMS35, BMS60, BMS100
-D25-FLB	Integral cables with D-style 25-pin feedback connector, flying leads for the motor, and a D-style 9-pin limit connector; compatible with: BMS35, BMS60, BMS100
-D25-5DU	Integral cables with D-style 25-pin feedback, D-style 5-pin motor, and D-style 9-pin limit connectors; compatible with: BMS35, BMS60, BMS100
-D25-9D-CMS	Integral cables with D-style 25-pin feedback, D-style 4-pin motor, and D-style 9-pin limit connectors and a cable management system; compatible with: BMS35, BMS60, BMS100
-D25-4TS	Integral cables with D-style 25-pin feedback, terminal block 4-pin motor, and D-style 9-pin limit connectors; compatible with: BMS35, BMS60, BMS100
Feedback Options	
-E1000H	1000 lines/rev TTL incremental encoder with Hall tracks
-E2000H	2000 lines/rev TTL incremental encoder with Hall tracks
-E2500H	2500 lines/rev TTL incremental encoder with Hall tracks
-E5000H	5000 lines/rev TTL incremental encoder with Hall tracks
-E1000ASH	1000 lines/rev 1 Vpp incremental encoder with Hall tracks

Brake (Optional)	
-BK	Holding brake
Cable Type (Optional)	
-HF	High-flex cable; compatible with: BMS35, BMS60, BMS100
Cable Length (Optional)	
-xx	Cable length from motor to connectors in decimeters; 3.8 dm is the default with a 50 dm maximum; compatible with: BMS35, BMS60, BMS100
Vacuum Preparation (Optional)	
-VAC6	Vacuum preparation to 10^{-6} Torr
Accessories	
MC-HPD25-M	High-power D-style motor mating connector
MC-DB25-F	D-style 25-pin mating connector
MCM-3	Military style motor power mating connector
MCF-3	Military style feedback mating connector

1.1. Motor Specifications

The specifications for the BM series brushless motors are listed in [Table 1-3](#), [Table 1-4](#), and [Table 1-5](#). The specifications for the BMS series brushless motors are listed in [Table 1-6](#) and [Table 1-7](#).

Table 1-3: BM24, BM75, and BM130 Motor Specifications

		BM24	BM75	BM130
Performance Specifications				
Stall Torque, Continuous	N·m	0.17	0.51	1.02
Peak Torque	N·m	0.51	1.30	2.50
Rated Speed	rpm	3,000	4,000	4,000
Rated Power Output, Continuous	W	53	192	333
Electrical Specifications				
BEMF Constant (Line-Line, Max)	V/krpm	6.6	9.0	19.0
Continuous Current, Stall	A	3.1	9.0	6.9
Peak Current, Stall	A	9.3	22.5	17.
Torque Constant	N·m/A	0.055	0.06	0.15
Motor Constant	N·m/√W	0.054	0.055	0.101
Resistance, 25 °C (Line-Line)	Ω	1.07	1.00	2.00
Inductance (Line-Line)	mH	0.75	1.42	3.52
Maximum Bus Voltage	VDC	80	340	340
Thermal Resistance	°C/W	N/A	1.18	1.04
Maximum Coil Temperature	°C	100	130	130
Number of Poles	--	6	8	8
Mechanical Specifications				
Frame Size	NEMA	17	23	23
Motor Weight	kg	0.80	1.	1.5
Rotor Moment of Inertia	kg·m ²	6.00 × 10 ⁻⁶	5.91 × 10 ⁻⁶	1.00 × 10 ⁻⁵
Max Radial Load	N	28	89	89
Max Axial Load	N	10	89	89
(1) Performance is dependent upon heat sink configuration, system cooling conditions, and ambient temperature. (2) All performance and electrical specifications have a tolerance of ±10%. (3) Values shown at maximum coil temperature, with housed motor mounted to a 305x305x12.7 mm ³ aluminum heat sink. (4) Peak torque assumes correct rms current; consult Aerotech. (5) Torque constant and motor constant specified at stall. (6) Ambient operating temperature range 0 °C - 25 °C; consult Aerotech for performance in elevated ambient temperatures. (7) All Aerotech motors and amplifiers are rated using vector amplitude values. For sinusoidal signals, use sine wave peak value.				

Figure 1-1: Torque Speed Curves (BM24, BM75, and BM130)

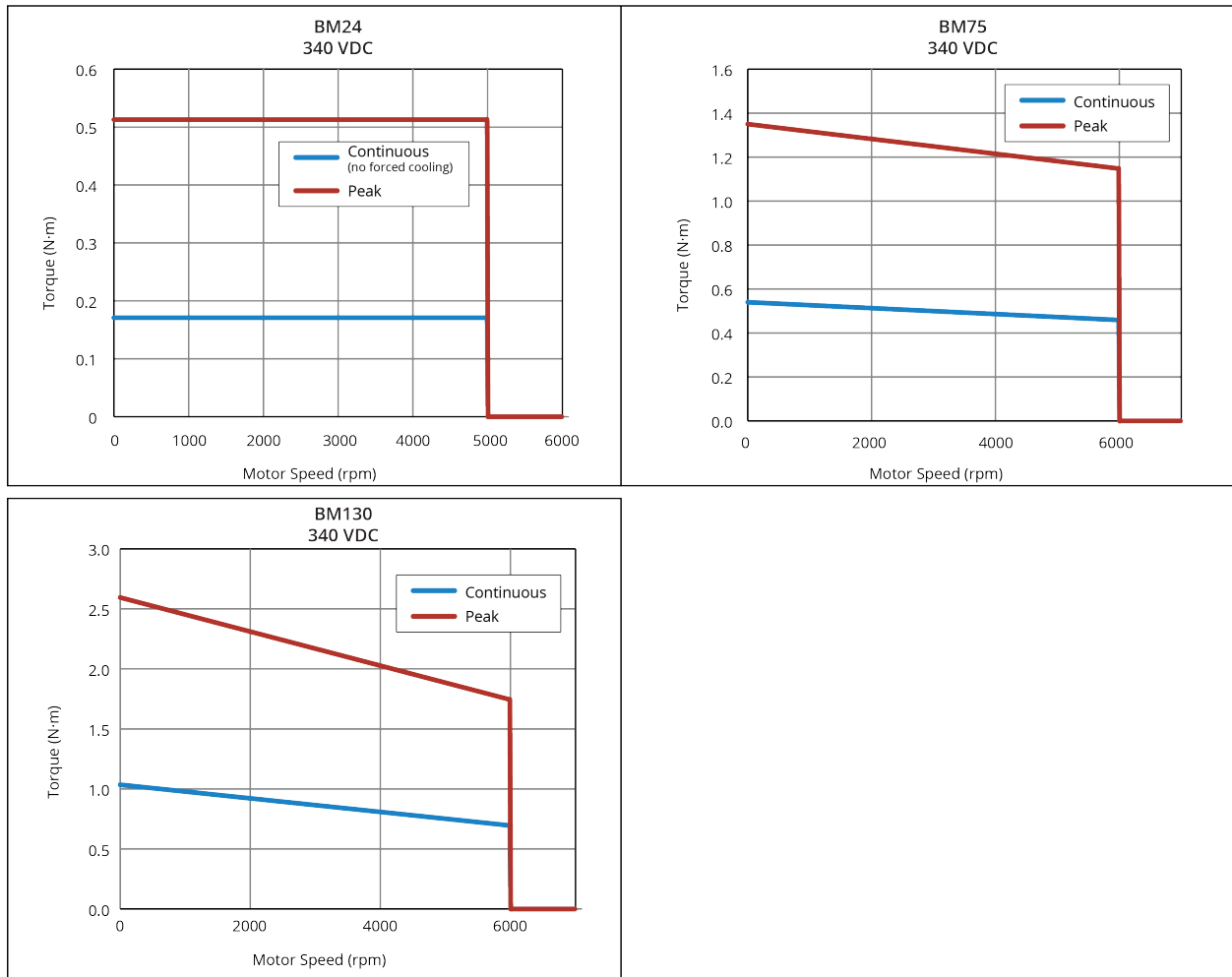

Table 1-4: BM200, BM250, and BM500 Motor Specifications

		BM200	BM250	BM500
Performance Specifications				
Stall Torque, Continuous	N·m	1.45	2.30	3.60
Peak Torque	N·m	3.60	5.70	9.10
Rated Speed	rpm	4,000	4,000	4,000
Rated Power Output, Continuous	W	455	739	1065
Electrical Specifications				
BEMF Constant (Line-Line, Max)	V/krpm	18.0	28.0	29.0
Continuous Current, Stall	A	10.3	10.3	17.5
Peak Current, Stall	A	25.8	25.6	43.8
Torque Constant	N·m/A	0.140	0.220	0.210
Motor Constant	N·m/√W	0.131	0.206	0.287
Resistance, 25 °C (Line-Line)	Ω	1.10	1.10	0.50
Inductance (Line-Line)	mH	2.18	2.74	1.42
Maximum Bus Voltage	VDC	340	340	340
Thermal Resistance	°C/W	0.81	0.82	0.61
Maximum Coil Temperature	°C	130	130	130
Number of Poles	--	8	8	8
Mechanical Specifications				
Frame Size	NEMA	23	34	34
Motor Weight	kg	2.0	3.6	5.0
Rotor Moment of Inertia	kg·m ²	1.30×10^{-5}	4.08×10^{-5}	7.57×10^{-5}
Max Radial Load	N	89	178	178
Max Axial Load	N	89	89	89
<p>(1) Performance is dependent upon heat sink configuration, system cooling conditions, and ambient temperature.</p> <p>(2) All performance and electrical specifications have a tolerance of ±10%.</p> <p>(3) Values shown at maximum coil temperature, with housed motor mounted to a 305x305x12.7 mm³ aluminum heat sink.</p> <p>(4) Peak torque assumes correct rms current; consult Aerotech.</p> <p>(5) Torque constant and motor constant specified at stall.</p> <p>(6) Ambient operating temperature range 0 °C - 25 °C; consult Aerotech for performance in elevated ambient temperatures.</p> <p>(7) All Aerotech motors and amplifiers are rated using vector amplitude values. For sinusoidal signals, use sine wave peak value.</p>				

Figure 1-2: Torque Speed Curves (BM200, BM250, and BM500)

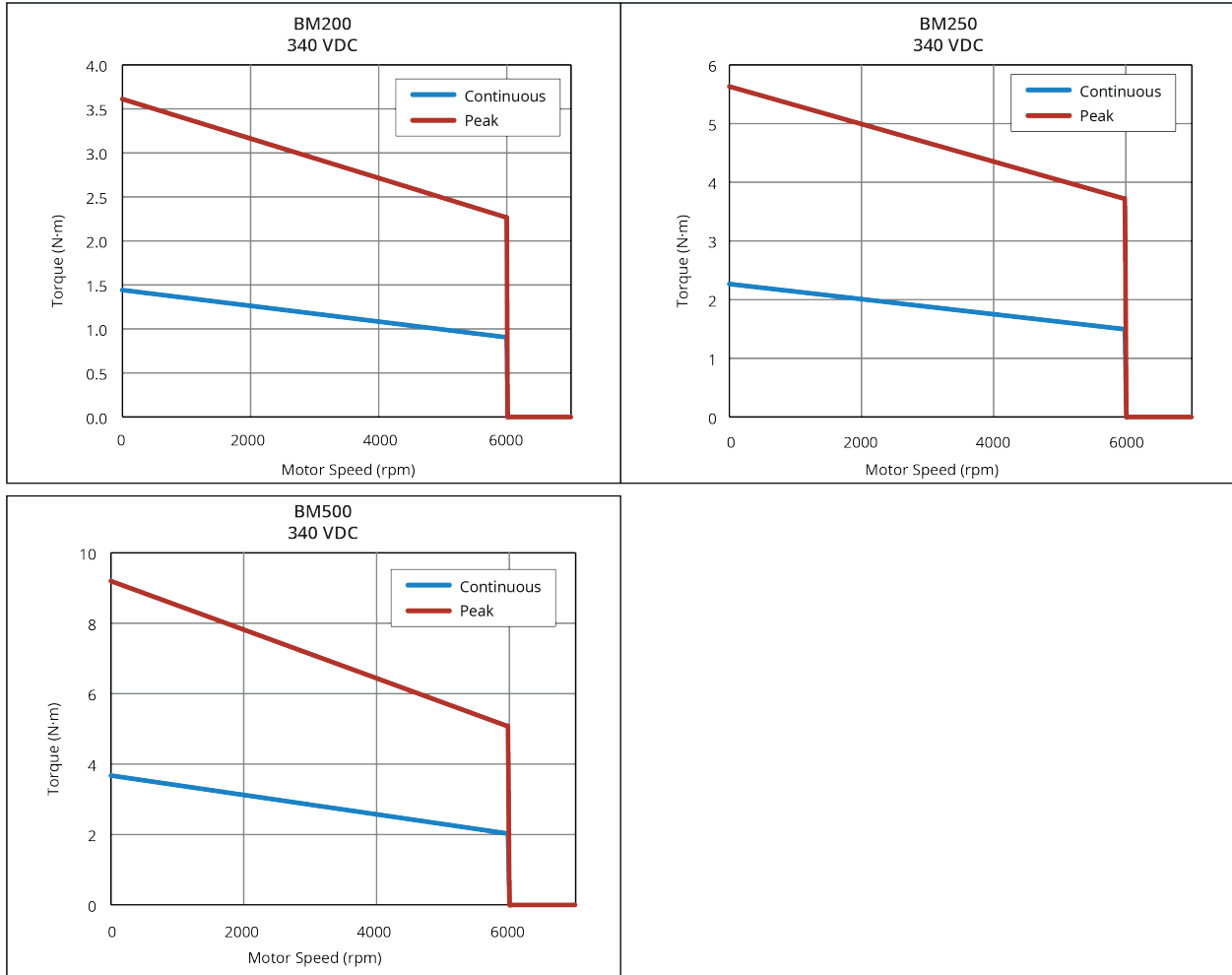

Table 1-5: BM800 and BM1400 Motor Specifications

		BM800	BM1400
Performance Specifications			
Stall Torque, Continuous	N·m	6.10	11.00
Peak Torque	N·m	15.30	27.60
Rated Speed	rpm	3,000	3,000
Rated Power Output, Continuous	W	1,446	2,529
Electrical Specifications			
BEMF Constant (Line-Line, Max)	V/krpm	69.0	69.0
Continuous Current, Stall	A	11.9	20.5
Peak Current, Stall	A	29.8	51.3
Torque Constant	N·m/A	0.510	0.540
Motor Constant	N·m/√W	0.451	0.745
Resistance, 25 °C (Line-Line)	Ω	1.20	0.50
Inductance (Line-Line)	mH	3.80	1.70
Maximum Bus Voltage	V _{DC}	340	340
Thermal Resistance	°C/W	0.60	0.54
Maximum Coil Temperature	°C	130	130
Number of Poles	--	8	8
Mechanical Specifications			
Frame Size	NEMA	42	42
Motor Weight	kg	6.6	10.7
Rotor Moment of Inertia	kg·m ²	2.44 × 10 ⁻⁴	5.60 × 10 ⁻⁴
Max Radial Load	N	222	222
Max Axial Load	N	89	89
<p>(1) Performance is dependent upon heat sink configuration, system cooling conditions, and ambient temperature.</p> <p>(2) All performance and electrical specifications have a tolerance of ±10%.</p> <p>(3) Values shown at maximum coil temperature, with housed motor mounted to a 305×305×12.7 mm³ aluminum heat sink.</p> <p>(4) Peak torque assumes correct rms current; consult Aerotech.</p> <p>(5) Torque constant and motor constant specified at stall.</p> <p>(6) Ambient operating temperature range 0 °C - 25 °C; consult Aerotech for performance in elevated ambient temperatures.</p> <p>(7) All Aerotech motors and amplifiers are rated using vector amplitude values. For sinusoidal signals, use sine wave peak value.</p>			

Figure 1-3: Torque Speed Curves (BM800 and BM1400)

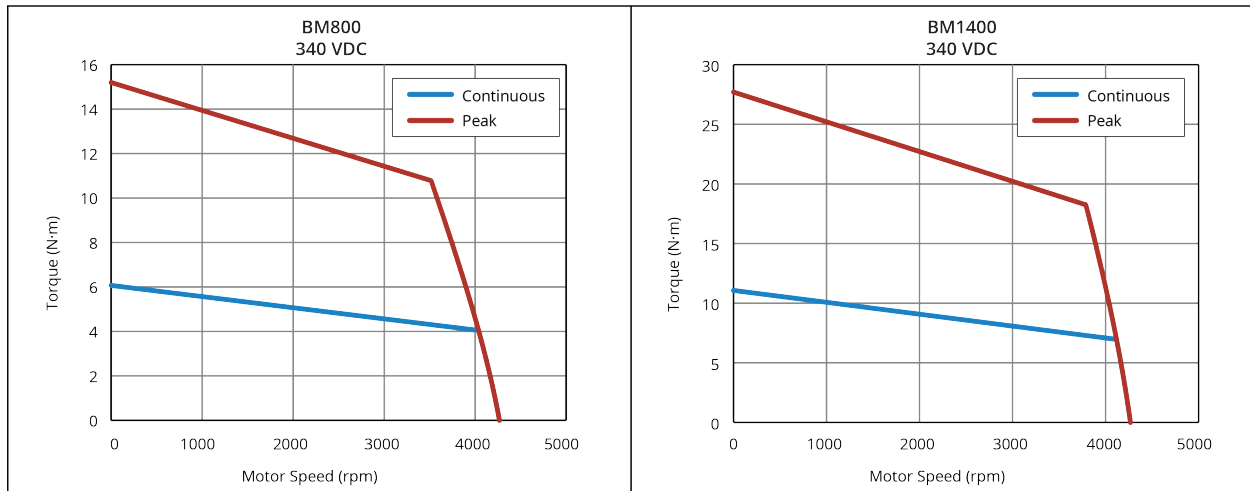

Table 1-6: BMS35, BMS60, and BMS100 Motor Specifications

		BMS35	BMS60	BMS100
Performance Specifications				
Continuous Stall Torque	N·m	0.27	0.32	0.59
Peak Torque	N·m	1.1	1.3	2.4
Rated Speed	rpm	4,000	4,000	3,000
Rated Power	W	97.0	126.4	146.7
Electrical Specifications				
BEMF Constant (Line-Line)	V/krpm	13.0	16.8	34.0
Continuous Current, Stall	A	2.5	2.3	2.1
Peak Current, Stall	A	9.8	9.2	8.4
Torque Constant	N·m/A	0.108	0.139	0.281
Motor Constant	N·m/√W	0.045	0.047	0.077
Resistance, 25 °C (Line-Line)	Ω	5.83	8.85	13.60
Inductance (Line-Line)	mH	1.57	1.98	3.40
Thermal Resistance	°C/W	2.11	1.64	1.28
Maximum DC Bus Voltage	V	340	340	340
Number of Poles	--	8	8	8
Maximum Coil Temperature	°C	100	100	100
Mechanical Specifications				
Frame Size	NEMA	17	23	23
Motor Weight	kg	0.60	1.10	1.50
Rotor Moment of Inertia	kg·m ²	0.0000186	0.0000196	0.0000370
<p>(1) Performance is dependent upon heat sink configuration, system cooling conditions, and ambient temperature.</p> <p>(2) Values shown at maximum coil temperature, with housed motor mounted to a 250x250x6 mm aluminum heat sink.</p> <p>(3) Peak torque assumes correct rms current; consult Aerotech.</p> <p>(4) Torque constant and motor constant specified at stall.</p> <p>(5) All performance and electrical specifications have a tolerance of ±10%.</p> <p>(6) Ambient operating temperature range 0 °C - 25 °C; consult Aerotech for performance in elevated ambient temperatures.</p> <p>(7) All Aerotech motors and amplifiers are rated using vector amplitude values. For sinusoidal signals, use sine wave peak value.</p>				

Figure 1-4: Torque Speed Curves (BMS35, BMS60, and BMS100)

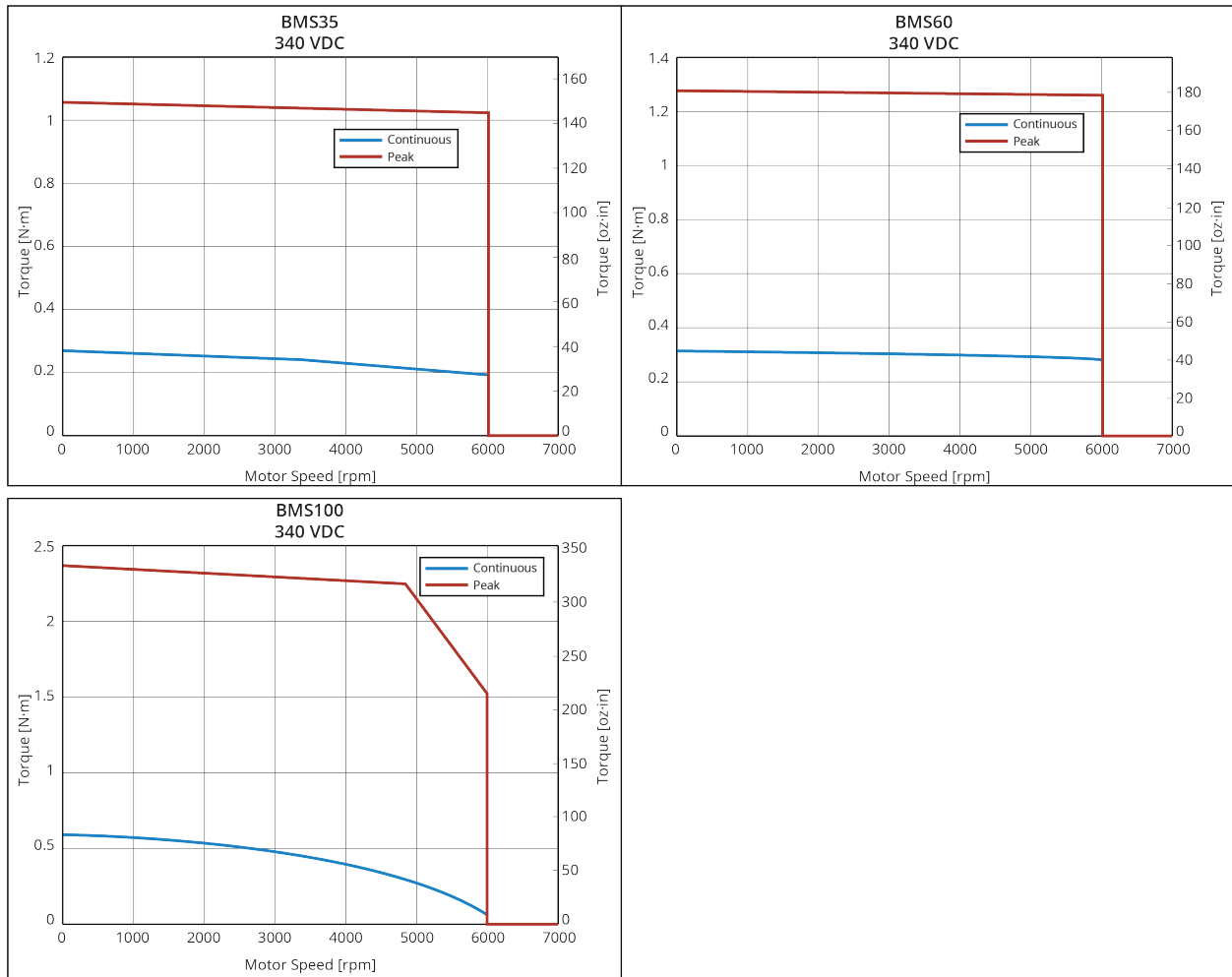
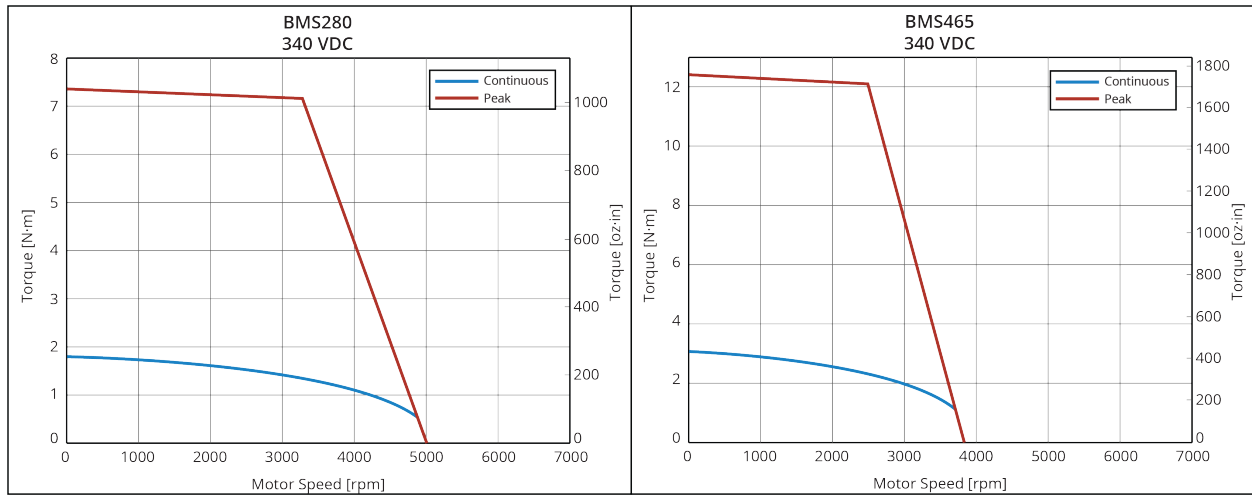

Table 1-7: BMS280 and BMS465 Motor Specifications

		BMS280	BMS465
Performance Specifications			
Stall Torque, Continuous	N·m	1.84	3.10
Peak Torque	N·m	7.3	12.4
Rated Speed	rpm	3,000	2,000
Rated Power	W	445.9	539.7
Electrical Specifications			
BEMF Constant (Line-Line, Max)	V/krpm	58.4	76.4
Continuous Current, Stall	A	3.8	4.9
Peak Current, Stall	A	15.2	19.6
Torque Constant	N·m/A	0.483	0.632
Motor Constant	N·m/√W	0.199	0.296
Resistance, 25 °C (Line-Line)	Ω	6.04	4.66
Inductance (Line-Line)	mH	1.32	1.06
Thermal Resistance	°C/W	0.88	0.69
Maximum Bus Voltage	VDC	340	340
Number of Poles	--	14	14
Maximum Coil Temperature	°C	100	100
Mechanical Specifications			
Frame Size	NEMA	34	34
Motor Weight	kg (lb)	3.60	5.00
Rotor Moment of Inertia	kg·m ²	0.0004328	0.0008568
<p>(1) Performance is dependent upon heat sink configuration, system cooling conditions, and ambient temperature.</p> <p>(2) Values shown at maximum coil temperature, with housed motor mounted to a 250x250x6 mm aluminum heat sink.</p> <p>(3) Peak torque assumes correct rms current; consult Aerotech.</p> <p>(4) Torque constant and motor constant specified at stall.</p> <p>(5) All performance and electrical specifications have a tolerance of ±10%.</p> <p>(6) Ambient operating temperature range 0 °C - 25 °C; consult Aerotech for performance in elevated ambient temperatures.</p> <p>(7) All Aerotech motors and amplifiers are rated using vector amplitude values. For sinusoidal signals, use sine wave peak value.</p>			

Figure 1-5: Torque Speed Curves (BMS280 and BMS465)



1.2. Dimensions

Figure 1-6: BM24 Model Dimensions (NEMA 17)

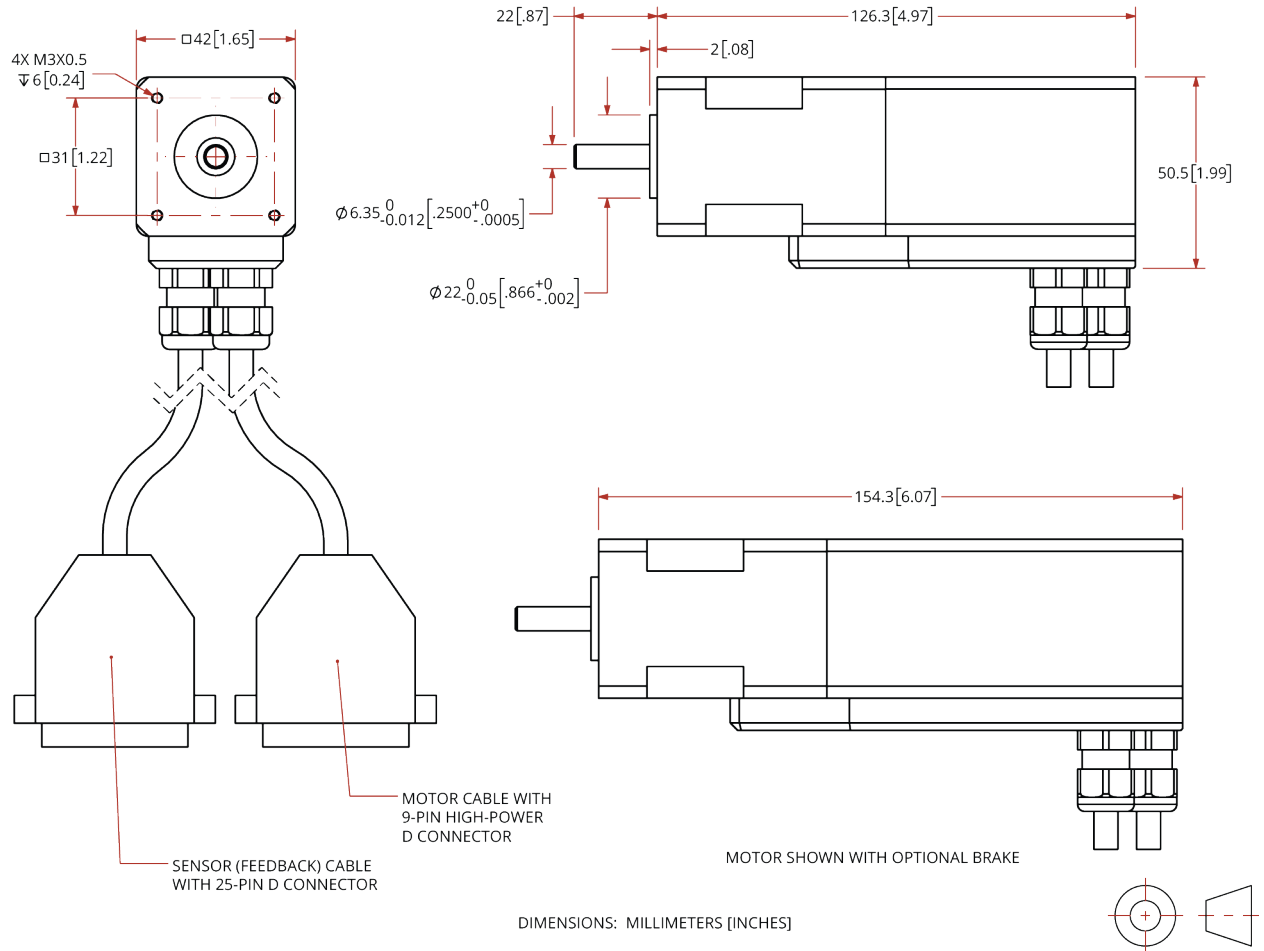

Figure 1-7: BM75, BM130, BM200 Model Dimensions (NEMA 23)

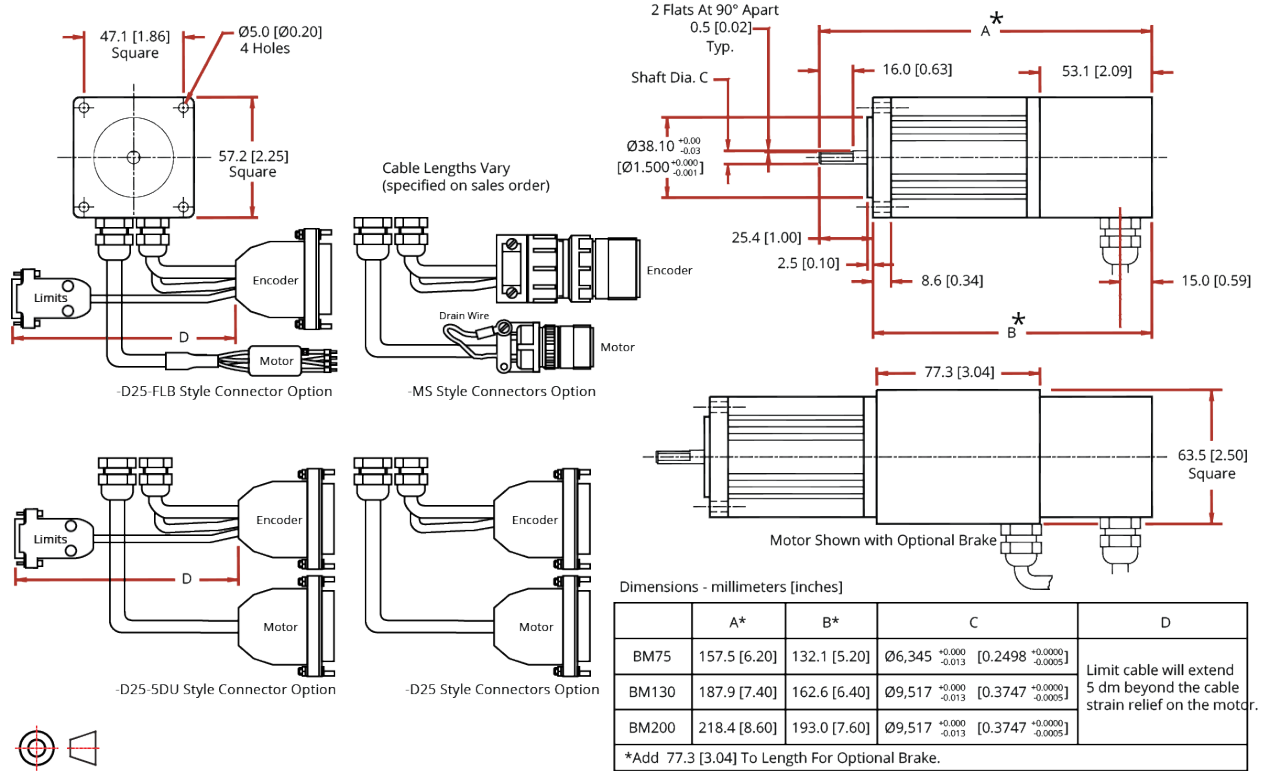
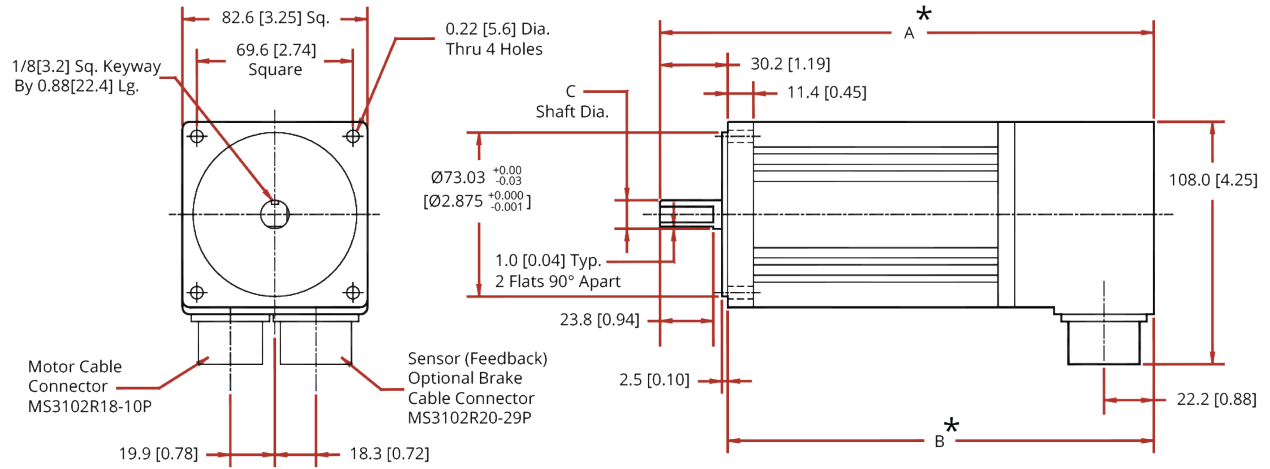

Figure 1-8: BM250, BM500 Model Dimensions (NEMA 34)



Dimensions - millimeters [inches]

	A*	B*	C
BM250	220.3 [8.67]	190.0 [7.48]	Ø12.69 ^{+0.000} / _{-0.013} [0.4997 ^{+0.0000} / _{-0.0005}]
BM500	275.1 [10.83]	244.9 [9.64]	Ø12.69 ^{+0.000} / _{-0.013} [0.4997 ^{+0.0000} / _{-0.0005}]

*Add 55.6 [2.19] To Length For Optional Brake.



Figure 1-9: BM800, BM1400 Model Dimensions (NEMA 42)

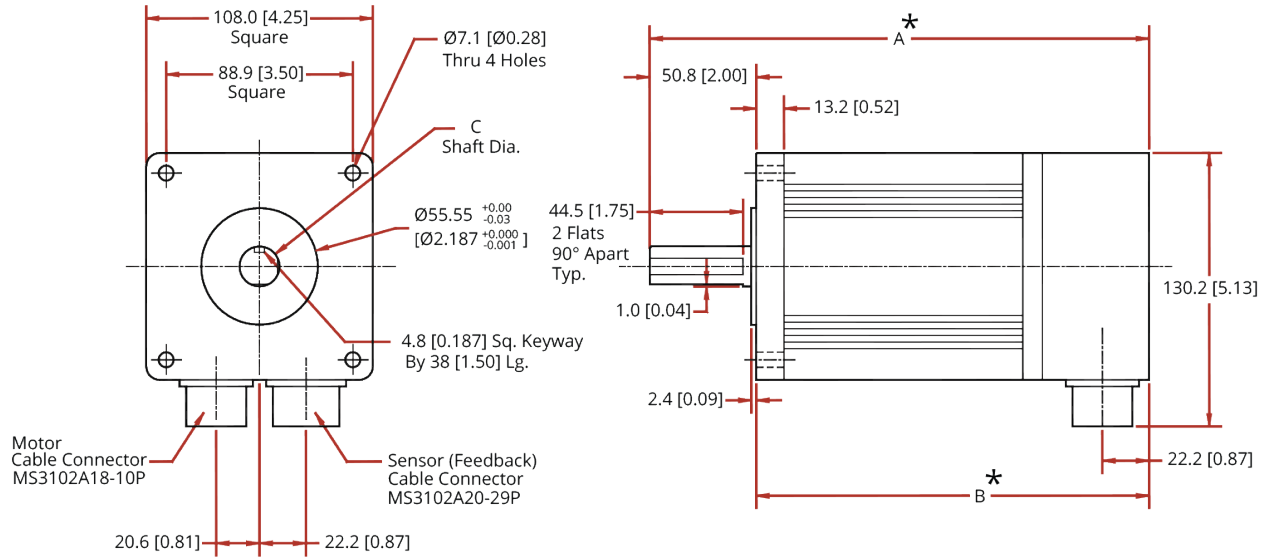

Dimensions - millimeters [inches]

	A*	B*	C
BM800	238 [9.37]	187 [7.37]	Ø19.04 ^{+0.000} / _{-0.013} [0.7497 ^{+0.0000} / _{-0.0005}]
BM1400	318 [12.52]	267.2 [10.52]	Ø19.04 ^{+0.000} / _{-0.013} [0.7497 ^{+0.0000} / _{-0.0005}]
*Add 68.9 [2.71] To Length For Optional Brake.			



Figure 1-10: BMS35 Model Dimensions (NEMA 17)

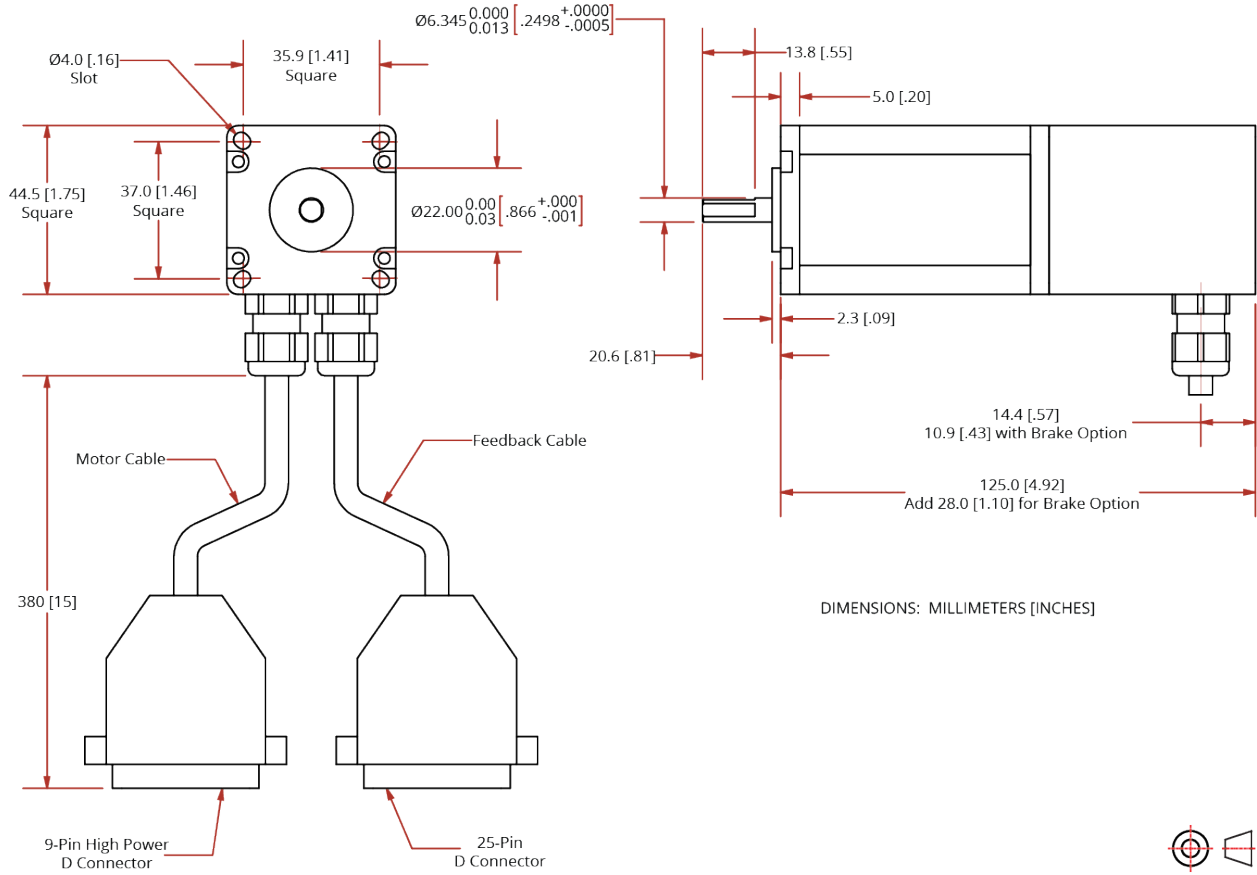

Figure 1-11: BMS60 and BMS100 Model Dimensions (NEMA 23)

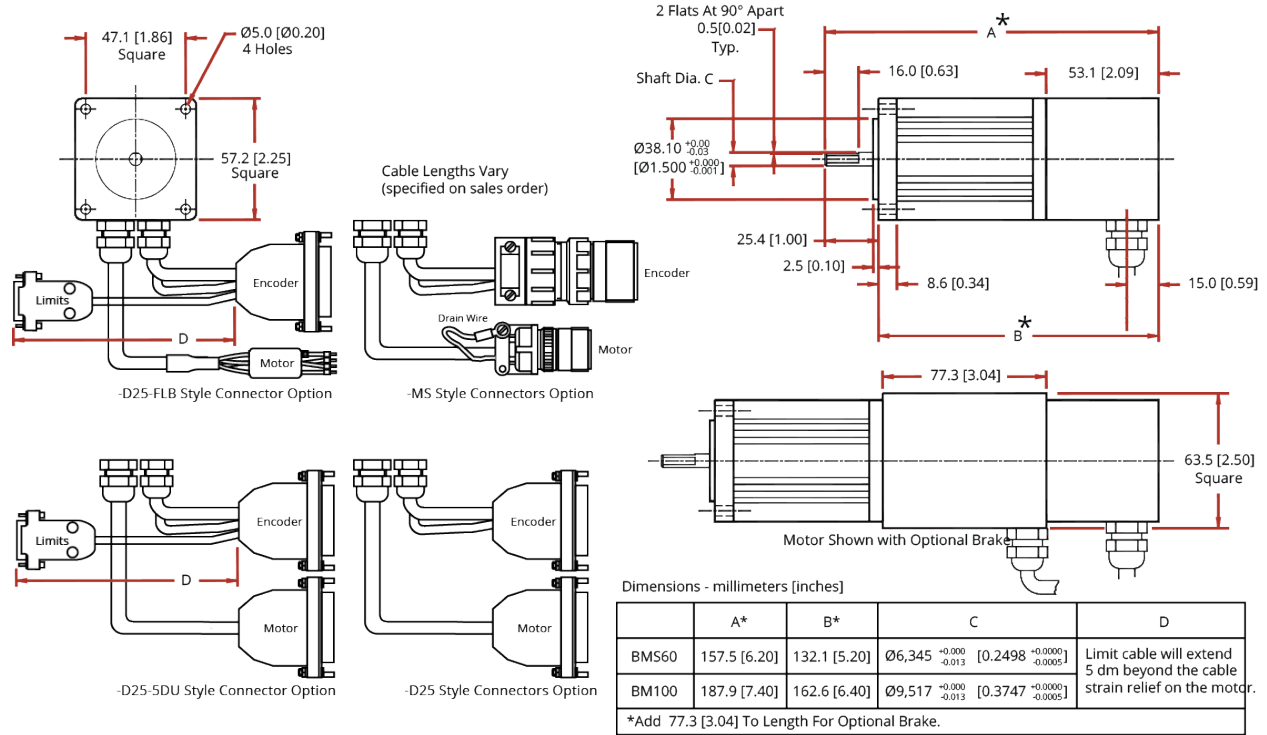
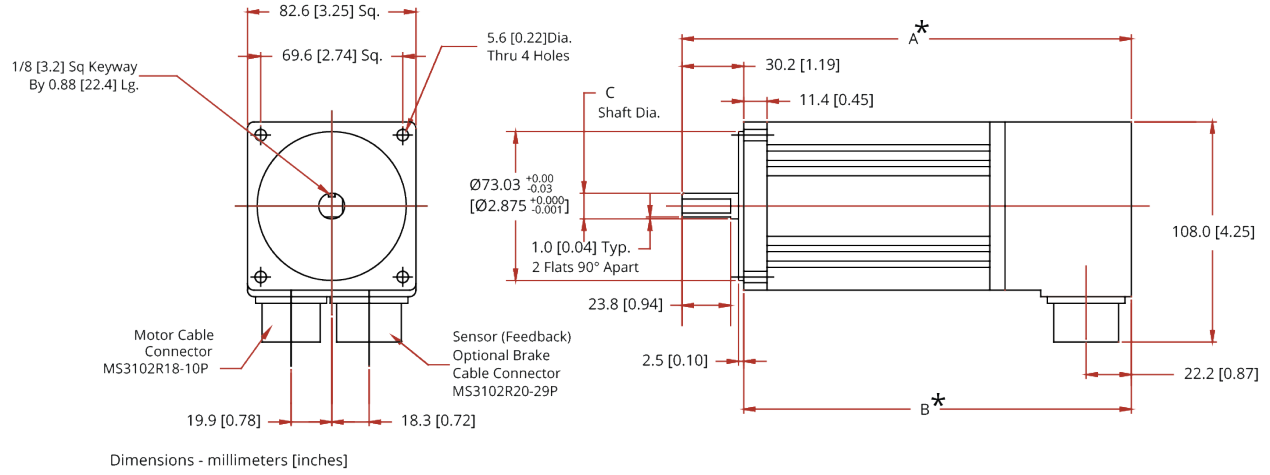

Figure 1-12: BMS280 and BMS465 Model Dimensions (NEMA 34)



Dimensions - millimeters [inches]

	A*	B*	C
BMS280	220.3 [8.67]	190.0 [7.48]	Ø12.69 ^{+0.000} / _{-0.013} [0.4997 ^{+0.0000} / _{-0.0005}]
BMS465	275.1 [10.83]	244.9 [9.64]	Ø12.69 ^{+0.000} / _{-0.013} [0.4997 ^{+0.0000} / _{-0.0005}]
*Add 55.6 [2.19] To Length For Optional Brake.			



1.3. Environmental Specifications



WARNING: Use this product only in environments and operating conditions that are approved in this manual.

Table 1-8: Environmental Specifications

Temperature:	Operating: 0 °C to 25 °C, consult Aerotech for operation outside of this range.
	Storage: -20 °C to 85 °C
Humidity:	Ambient conditions need to be such that condensation on the motor does not occur. The motors are not to be used in wash-down environments (unless ordering with the IP65 option).
Dust Exposure:	The BM and BMS motors are rated IP40. The BM250, 500, 800, 1400, and 2000 can be ordered, as an option, with IP65 protection.
Altitude:	Up to 2,000 m. Consult Aerotech for derating considerations for altitudes above 2,000 m.
Use:	Indoor use only.
Atmosphere:	Do not use in hydrogen atmospheres

1.4. Vacuum Operation

There are two vacuum preparation options:

- Low Vacuum (for use in environments from atmospheric pressure, down to 10^{-3} Torr)
- High Vacuum (for use in environments from 10^{-3} Torr, down to 10^{-6} Torr)

Special preparations include:

- Parts are lubricated with vacuum-compatible lubricants.
- Materials, fasteners, and coatings are selected to be compatible with the specified level of vacuum.
- High-vacuum systems are designed to eliminate trapped volumes.
- Prior to assembly, motor parts are thoroughly cleaned in a clean environment.
- The motor is packaged in a special polyethylene bag.

Vacuum Guidelines

To ensure that the motor will continue to perform well in the vacuum environment, use the guidelines that follow (in addition to standard handling, installation, and lubrication guidelines outlined in this manual).

1. Do not remove the motor from its sealed bag until it is ready to use.
2. Always handle the motor in a clean environment and use powder-free polyethylene gloves to prevent any contaminants from adhering to the surface of the motor.
3. During installation, use cleaned, vented, stainless steel fasteners to secure the motor.
4. Reduced air pressure eliminates significant convective heat transfer. This, coupled with the viscous vacuum-compatible lubricants, could result in excessive motor operating temperatures. Because of this, consider all continuous torque ratings to be **40 to 60% lower** than the value specified for operation in normal atmospheric environment. Reduce motor usage accordingly.
5. We recommend that you use a small quantity of **Braycote® 602EF** grease or a compatible substitute of equal quality lubricant in vacuum applications.
6. To reduce outgassing during the initial pump-down to vacuum pressure, Aerotech recommends that you bake out vacuum systems when you first install them into the vacuum chamber. Bake the vacuum components at 60 °C for 24 to 48 hours to desorb water vapor from surfaces and degas polymers (such as cable insulation).

This page intentionally left blank.

Chapter 2: Assembly and Installation



WARNING: To prevent injury or damage to the equipment, you will need devices in place that will prevent unexpected motion in the event of an intentional or unintentional disruption of electrical power. Applications with vertical axes require a fail-safe brake.

2.1. Connector Pinout

Table 2-1: Motor Connector Options

Option	Connector Description	Pinout Table
-MS	Military style connectors	Table 2-4
-D25	4 pin D-style connector	Table 2-6
-D25-9D		
-D25-9D-CMS		
-D25-FLB	Flying leads	Table 2-8
-D25-4TS	4 pin terminal block connector	Table 2-9
-D25-5D	5 pin D-style connector	Table 2-10

Table 2-2: Feedback Connector Options

Option	Connector Description	Pinout Table
-MS	Military style connectors	Table 2-12
-D25	25 pin D-style connector (no limits)	Table 2-14
-D25-9D	25 pin D-style connector (with limits)	Table 2-16
-D25-9D-CMS		
-D25-5D		
-D25-FLB		
-D25-4TS		

Table 2-3: Limit Connector Options

Option	Connector Description	Pinout Table
-D25-9D	9 pin D-style connector	Table 2-18
-D25-9D-CMS		
-D25-5D		
-D25-FLB		
-D25-4TS		

2.1.1. Motor Connectors



DANGER: Do not allow motor connection cables to contact the motor frame while the motor is in operation.

Table 2-4: Motor Power Connector Pinout (-MS Option)

Pin	Description	Connector
A	Motor Phase A	 <p>P/N: MS3101A18-10P</p>
B	Motor Phase B	
C	Motor Phase C	
D	Frame Ground (motor protective ground)	
Backshell	Motor Cable Shield	

Table 2-5: Mating Connector Part Numbers for the Motor Power Connector (-MS Option)

Mating Connector	Aerotech P/N	Third Party P/N
Plug	MCM00475	Amphenol MS3106A18
Insert	MCM00495	Amphenol 9718-10S
Bushing	MCM00481	DDK MS3055-18-10
Clamp	MCM00477	Amphenol MS3057A-10

Note: All parts are nickel-plated

Table 2-6: Motor Connector Pinout (-D25 Option)

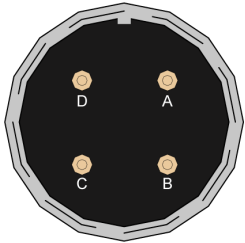
Pin	Description	Connector
Case	Shield Connection	
A1	Motor Phase A	
A2	Motor Phase B	
A3	Motor Phase C	
1	Reserved	
2	Reserved	
3	Reserved	
4	Reserved	
5	Reserved	
A4	Frame Ground (motor protective ground)	

Table 2-7: Mating Connector Part Numbers for the Motor Power Connector (-D25 Option)

Mating Connector	Aerotech P/N	Third Party P/N
Backshell	ECK00656	Amphenol #17E-1726-2
Sockets [QTY. 4]	ECK00659	ITT Cannon #DM53744-6
Connector	ECK00657	ITT Cannon #DBM9W4SA197

Table 2-8: Motor Power Flying Leads Pinout (-D25-FLB Option)

Wire	Description	Flying Leads
Black	Motor Phase A	
Red	Motor Phase B	
White	Motor Phase C	
Green/ Yellow	Frame Ground and Shield Connection	

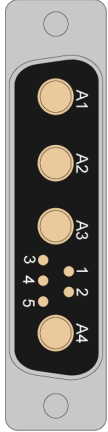
Table 2-9: Motor Power Terminal Block Pinout (-D25-4TS Option)

Wire	Description	Terminal Block
White	Motor Phase C	
Red	Motor Phase B	
Black	Motor Phase A	
Green/ Yellow	Frame Ground and Shield Connection	

Table 2-10: Motor Connector Pinout (-D25-5D Option)

Pin	Description	Connector
Case	Shield Connection	
A1	Motor Phase A	
A2	Motor Phase B	
A3	Motor Phase C	
A4	Reserved	
A5	Frame Ground (motor protective ground)	

Table 2-11: Mating Connector Part Numbers for the -D25-5D Option Motor Power Connector

Mating Connector	Aerotech P/N	Third Party P/N
Backshell	ECK00656	Amphenol #17E-1726-2
Sockets [QTY. 5]	ECK00659	ITT Cannon #DM53744-6
Connector	ECK01229	ITT Cannon #DBME5W5SA197

2.1.2. Feedback Connectors

Table 2-12: Feedback Connector Pinout (-MS Option)

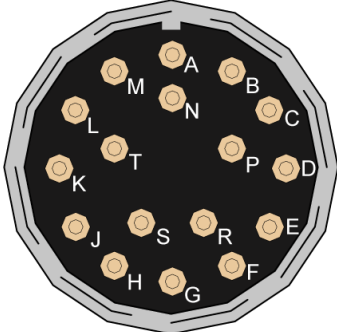
Pin	Description	Connector
Case	Shield Connection	 <p>P/N: MS3102R20-29P</p>
A	COS+ (Encoder Cosine+)	
B	COS- (Encoder Cosine-)	
C	SIN+ (Encoder Sine+)	
D	SIN- (Encoder Sine-)	
E	MRK+ (Encoder Marker+)	
F	MRK- (Encoder Marker-)	
G	Common ground	
H	5V Power Supply Input	
J	Reserved	
K	Hall Effect Sensor (Phase A)	
L	BMS Motors: Over-Temperature Thermistor Sensor ⁽¹⁾ BM Motors: Reserved	
M	Hall Effect Sensor (Phase B)	
N	Reserved	
P	Hall Effect Sensor (Phase C)	
R	Reserved	
S	Reserved Brake + (with Brake Option) ⁽¹⁾	
T	Reserved Brake - (with Brake Option) ⁽¹⁾	

(1) 24 VDC @ 1 A max

Table 2-13: Mating Connector Part Numbers for the -MS Option Feedback Connector

Mating Connector	Aerotech P/N	Third Party P/N
Plug	MCM00454	Amphenol MS3106A-20
Insert	MCM00464	Amphenol MS20-29S
Clamp	MCM00457	97-3057-1012
Bushing	MCM00493	Amphenol AN3055-22-12

Note: All parts are nickel-plated

Table 2-14: Feedback Connector Pinout (without Limits, -D25 Option)

Pin	Description	Connector
Case	Shield Connection	
1	Reserved	
2	BMS Motors: Over-Temperature Thermistor Sensor	
	BM Motors: Reserved	
3	5V Power Supply Input	
4	Reserved	
5	Hall Effect Sensor (Phase B)	
6	MRK- (Encoder Marker-)	
7	MRK+ (Encoder Marker+)	
8	Reserved	
9	Reserved	
10	Hall Effect Sensor (Phase A)	
11	Hall Effect Sensor (Phase C)	
12	Reserved	
13	Reserved	
	Brake - (with Brake Option)	
14	COS+ (Encoder Cosine+)	
15	COS- (Encoder Cosine-)	
16	Reserved	
17	SIN+ (Encoder Sine+)	
18	SIN- (Encoder Sine-)	
19	Reserved	
20	Common ground (PIN 20 is internally connected to PIN 21)	
21	Common ground (PIN 21 is internally connected to PIN 20)	
22	Reserved	
23	Reserved	
24	Reserved	
25	Reserved	
	Brake + (with Brake Option)	

Table 2-15: Mating Connector Part Numbers for the -D25 Option Feedback Connector

Mating Connector	Aerotech P/N	Third Party P/N
25-Socket D-Connector	ECK00300	FCI DB25S064TLF
Backshell	ECK00656	Amphenol 17E-1726-2

Table 2-16: Feedback Connector Pinout (with Limits, -D25-9D, -9D-CMS, -5D, -FLB, -4TS)

Pin	Description	Connector
Case	Shield Connection	
1	Reserved	
2	BMS Motors: Over-Temperature Thermistor Sensor	
	BM Motors: Reserved	
3	5V Power Supply Input (PIN 3 is internally connected to PIN 16)	
4	Reserved	
5	Hall Effect Sensor (Phase B)	
6	MRK- (Encoder Marker-)	
7	MRK+ (Encoder Marker+)	
8	Reserved	
9	Reserved	
10	Hall Effect Sensor (Phase A)	
11	Hall Effect Sensor (Phase C)	
12	+Limit/CW (Positive/Clockwise Travel Limit)	
13	Reserved	
	Brake - (with Brake Option)	
14	COS+ (Encoder Cosine+)	
15	COS- (Encoder Cosine-)	
16	5V Power Supply Input (PIN 16 is internally connected to PIN 3)	
17	SIN+ (Encoder Sine+)	
18	SIN- (Encoder Sine-)	
19	Reserved	
20	Common ground (PIN 20 is internally connected to PIN 21)	
21	Common ground (PIN 21 is internally connected to PIN 20)	
22	Home Limit	
23	Reserved	
24	-Limit/CCW (Negative/Counterclockwise Limit)	
25	Reserved	
	Brake + (with Brake Option)	

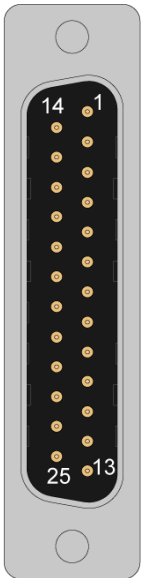
Table 2-17: Mating Connector Part Numbers for the -D25-XX Feedback Connector

Mating Connector	Aerotech P/N	Third Party P/N
25-Socket D-Connector	ECK00300	FCI DB25S064TLF
Backshell	ECK00656	Amphenol 17E-1726-2

Table 2-18: Limit Connector Pinout (-D25-9D,-9D-CMS, -5D, -FLB, -4TS)

Pin	Description	Limits Connector
Case	Shield Connection	
1	5V Power Supply Limit Input	
2	Limit Common	
3	+Limit/CW (Positive/Clockwise Travel Limit)	
4	Home Limit	
5	-Limit/CCW (Negative/Counterclockwise Limit)	
6	Reserved	
7	Common ground	
8	Reserved	
9	Reserved	

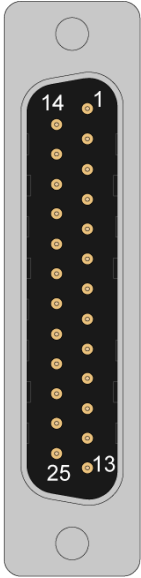
Table 2-19: Mating Connector Part Numbers for the Limit Connector

Mating Connector	Aerotech P/N	Third Party P/N
9-Pin D-Connector	ECK00340	FCI DE09S064TLF
Backshell	ECK01021	Amphenol 17E-1724-2

2.2. External Motor Wiring

It is the responsibility of the customer to supply all external wiring. Customer-supplied wiring must obey all local electrical safety requirements.

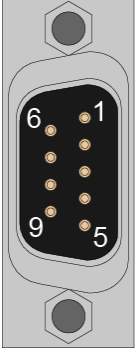
- The wiring must be able to supply the rated current without overheating.
- The wire insulation must be rated for the voltage and temperature at which the motor is operating.
- Cable selection and installation should be made to reduce EMI emissions and to increase EMI immunity.

In addition to the external wiring, it is also the responsibility of the customer to provide over-current protection for the motor.

2.2.1. Motor Power Conductors

The motor power conductors must be sized to handle the electrical current requirements of the motor (refer to [Section 1.1. Motor Specifications](#)). Select the wire insulation voltage rating based on the maximum voltage that will be applied to the motor.

2.2.2. Protective Ground

The protective ground is a safety conductor that you must use to ground the motor case. The protective ground conductor must have a current carrying capacity at least equal to the carrying capacity of the motor wires. The standard insulation is "Green/Yellow" and must be rated for the maximum voltage applied to the motor winding. The protective ground wire is typically bundled with the motor wires, but your system could require a separate protective ground wire.

2.2.3. Over-Current Protection

You will need to provide the motor with over-current protection to prevent the motor from overheating. Use programmable current limits, traps, over-current protection circuitry, or fuses. Fuse values should be selected according to the RMS current rating of the motor. For most applications, you should use slow-blow type fuses.

When the motor is part of an Aerotech system that uses an Aerotech controller and drive, use the " A_{pk} " continuous current rating to set the motor over-current protection fault (refer to [Section 1.1.](#)). If the motor is not installed in a system configured by Aerotech, you must provide the over-current protection.

2.2.4. Hall-Effect Device and Thermistor Wiring

The insulation of these wires should have a rating for at least the maximum voltage applied to the motor winding. The temperature rating of the wire insulation must also be sufficiently high to withstand the operating temperatures specific to the application.

2.2.5. Wiring Guidelines

The wiring guidelines given below can help to reduce EMI related problems which can result in poor overall system performance.

- Keep cable lengths as short as possible. Long cable runs are more susceptible to EMI pickup than short runs.
- Use grounded shielded cables for both the motor power and signal wiring.
- Use twisted pair shielded cabling to help reduce magnetically induced currents.
- Braided shield has a slightly better low frequency shielding capability than a foil shield. Foil is often used where RF shielding is necessary.
- Do not bundle signal, motor power cables, or AC power lines within the same protective shield or conduit. Use separate protective shields or conduits.
- Do not introduce multiple paths to ground from a grounding point. Multiple paths to ground can create ground loops within the system.
- If necessary, use an EMI suppression device.

2.2.6. Thermal Protective Device [BMS Motors Only]

BMS motors use a positive-temperature coefficient (PTC) thermistor as a thermal protection device. The nominal resistance of the thermistor is 100 ohms at 25 °C. The resistance of the thermistor will increase rapidly to 1,000 ohms as the motor temperature increases to the 100 °C transition temperature of the thermistor.



WARNING: The thermal protective device used in the motor must be connected to an external shutdown circuit to provide protection to the motor.

Figure 2-1: Thermal Sensor Resistance as a Function of Temperature

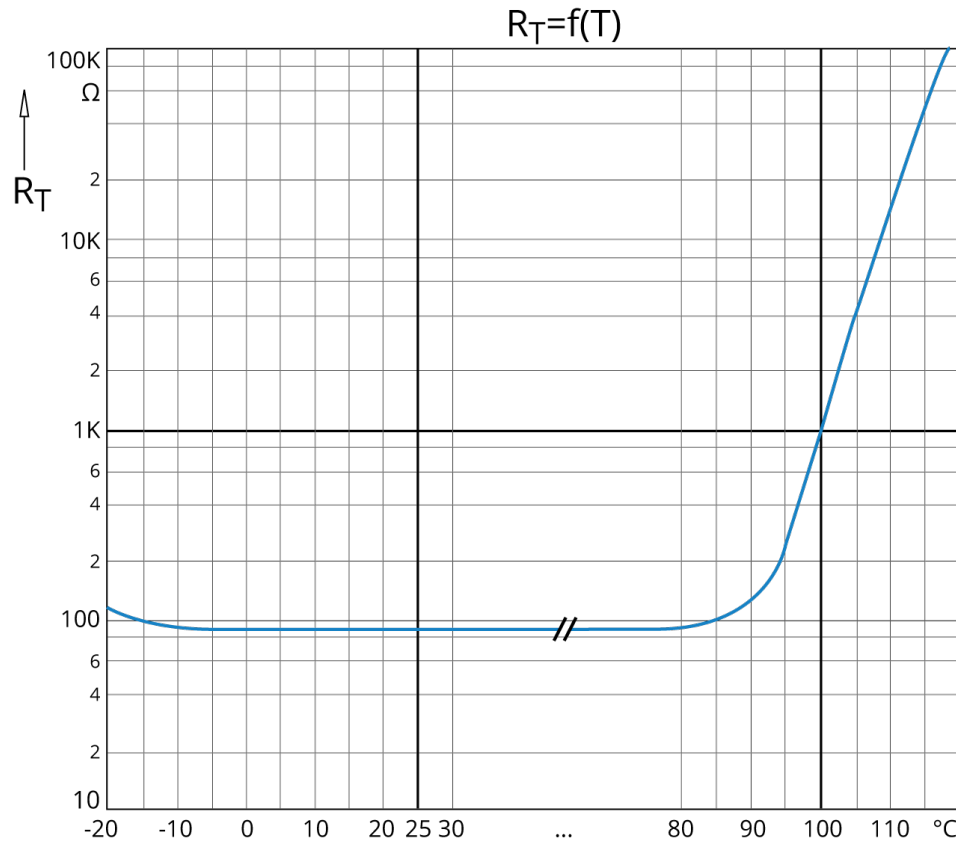



WARNING: If you connect the thermistor to the interface circuit incorrectly, you could cause the thermistor to self-heat. If too much current passes through the thermistor, the temperature will increase and cause the thermistor to activate and increase resistance.

Figure 2-2: Typical Thermistor Interface Circuit

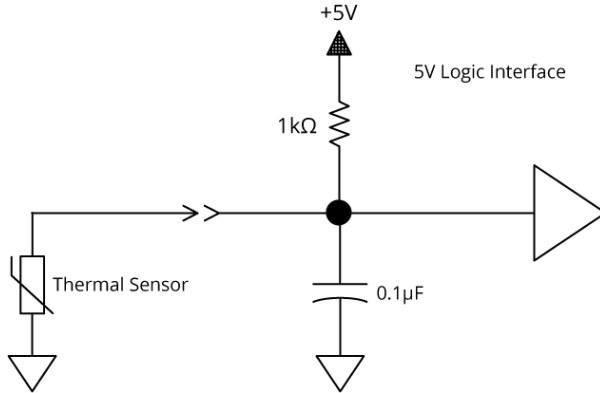

2.3. Hall-Effect Operation and Motor Phasing

Aerotech brushless motors are shipped from the factory with the correct motor phase to Hall effect relationship. Figure 2-3 shows the correct Hall effect to motor phasing for both clockwise (CW) and counterclockwise (CCW) motor rotation.

Figure 2-3: Hall Effect and Motor Phasing

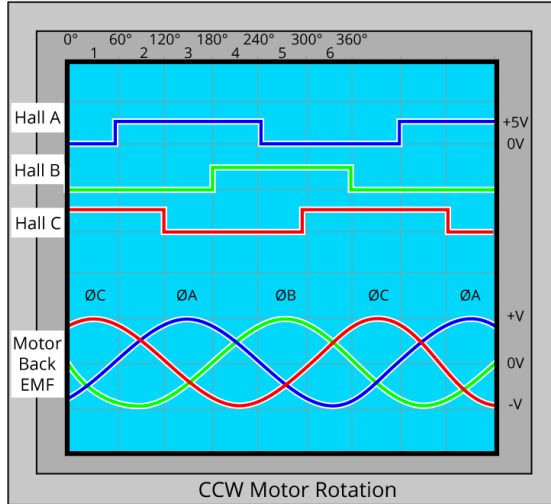

During CCW motor rotation, each Hall effect signal is at a logic low state when its corresponding motor phase is at a negative voltage.

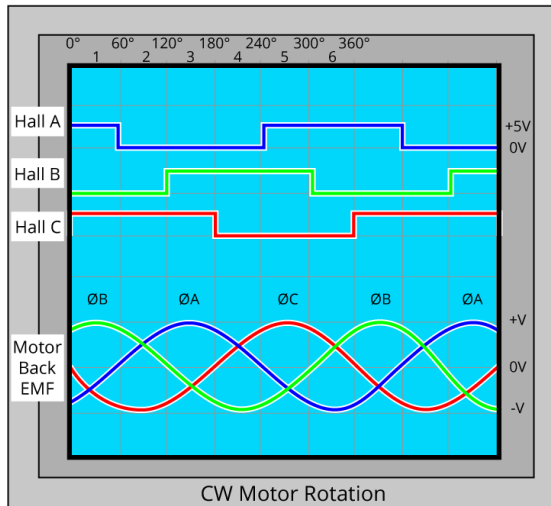

During CW rotation, each Hall effect signal is at a logic high state when its corresponding motor phase is at a negative voltage.



To observe the waveforms of the motor BEMF, use an oscilloscope, a 5 V power supply, and six 10,000 ohms resistors (Figure 2-4). To view the waveforms, remove all electrical connections to the motor, and configure the setup as shown in Figure 2-4. Connect the ends of motor leads 1, 2, and 3 to the three resistors as shown. The Hall device power connections are as shown. The three Hall signal wires are connected via the remaining three resistors to the 5 V lead of the power supply.

Figure 2-4: Test Setup Configuration

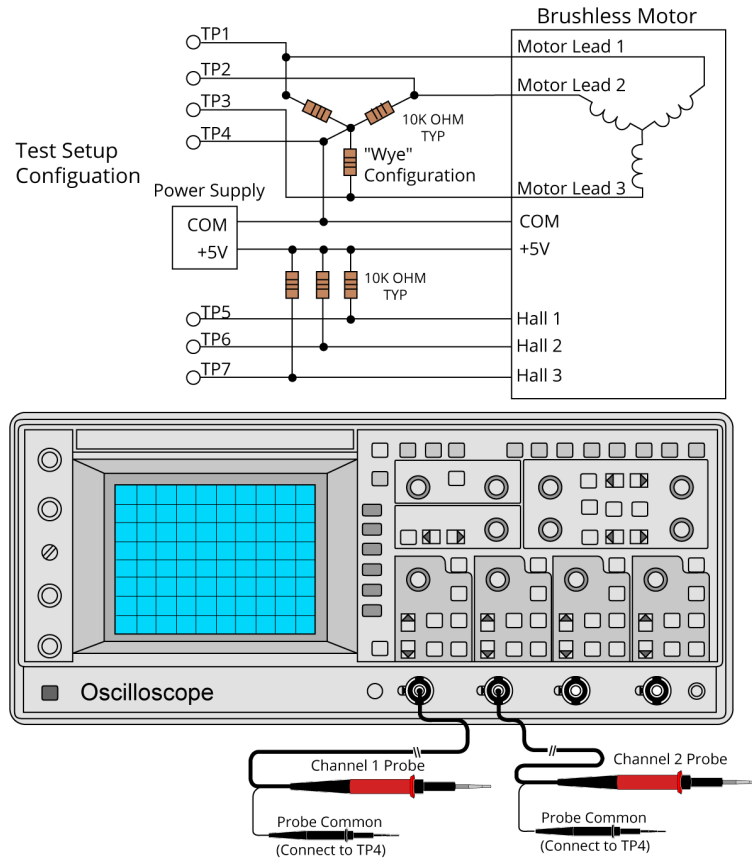

WARNING: The motor BEMF is monitored without power applied to the motor. Before performing these steps, remove all connections to the motor that are not part of the test setup shown in the figures. Remove all mechanical connections to the motor shaft also.

To determine the relative phasing/order of the three motor windings in relation to each other, connect channel 1 of the oscilloscope to TP1. Connect channel 2 to TP2 and move the motor in the positive direction (CW) by hand. Note the peak of the sine wave of channel 1 in comparison to the peak of the sine wave of channel 2. Next, disconnect channel 2 from TP2 and reconnect it to TP3 and again move the motor in the positive direction. Note the peak of the sine wave of channel 3 in comparison to the peak of the sine wave of channel 1.

Aerotech phasing expects ØC to be the lead signal in time, ØB to follow it, and ØA to follow ØB. This means that whichever signal has been determined to lead the others in time is designated as the ØC winding.

Figure 2-5: Motor Lead Phasing with Oscilloscope

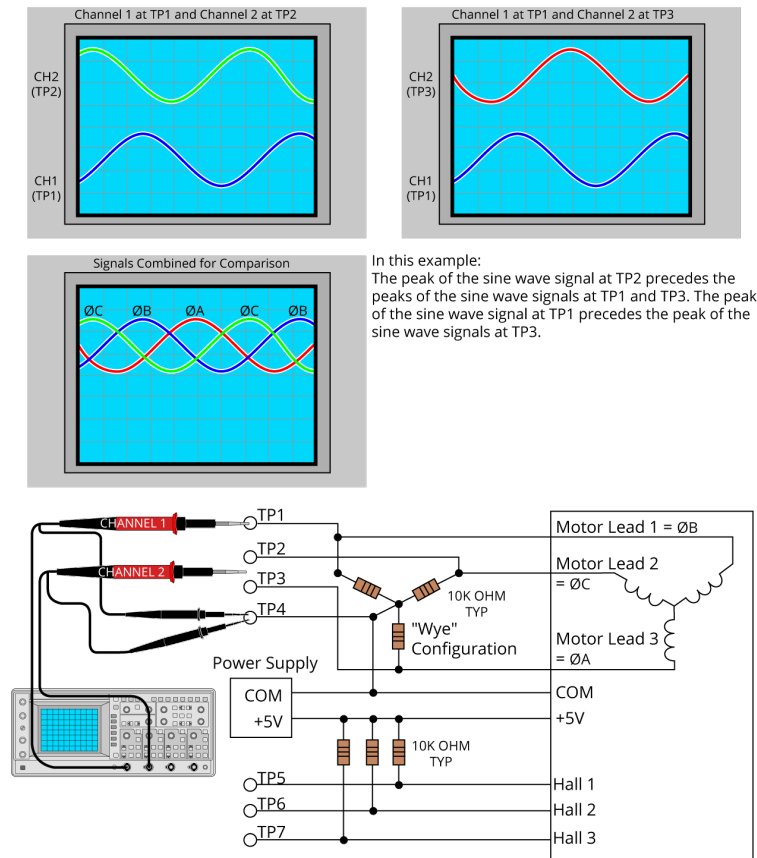

After the phase relationships of the motor have been determined, the next step is to determine the phase relationships of the Hall signals. The expected relationship between motor BEMF and the Hall signal is the peak of the BEMF. This relationship should correspond to the low voltage phase of the Hall signal. The relationship is shown in [Figure 2-6](#).

With channel 1 still connected to one of the motor leads, connect channel 2 of the oscilloscope to TP5, TP6, and then TP7, while advancing the motor in the positive direction after each connection. Note which of the three Hall signals have the complimentary phase relationship to the motor lead connected to channel 1.

Move channel 1 of the oscilloscope to the second motor lead and repeat the steps given above. Note which Hall signal corresponds to the currently selected motor lead. Repeat the process for the third motor lead until the desired relationships are attained and noted.

Figure 2-6: Hall Phasing with Oscilloscope

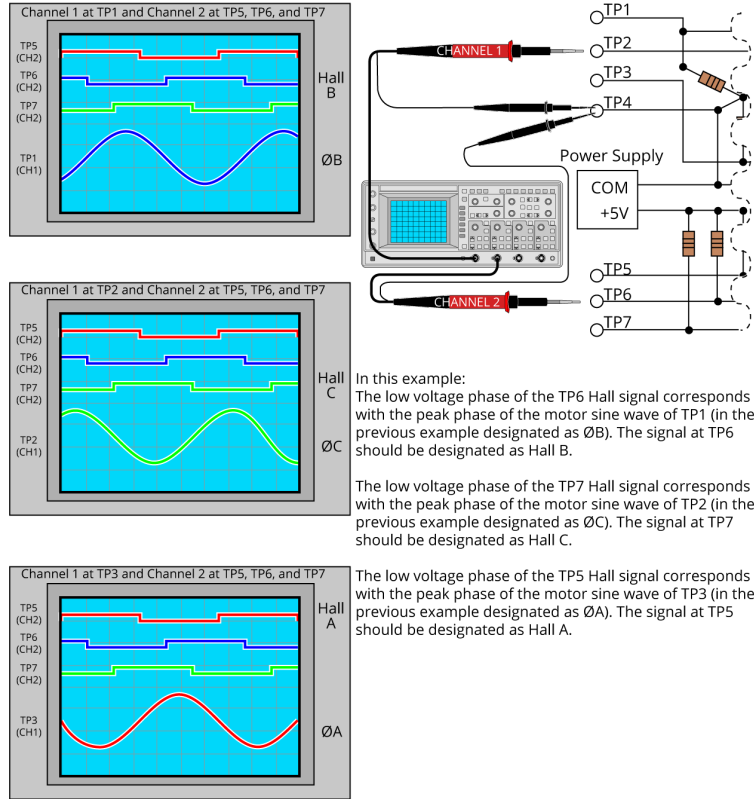

2.4. Motor Heating

The amount of current that can pass through the motor winding is limited by a rise in temperature above ambient.

For BM Motors: If the temperature of the motor exceeds the thermal limit, the motor will overheat. This could cause damage to the motor or system.



WARNING: This motor does not have a built-in over-temperature feature. It is your responsibility to find the correct duty cycle and to not exceed the maximum operating temperature.

For BMS Motors: If the temperature of the motor exceeds the thermal limit, the thermistor sensor will send a signal to the controller and the controller will stop the motor.

The motor specifications show the continuous motor current that will result in a predetermined temperature rise of the motor. The motor specifications listed in [Section 1.1](#) were compiled under a single set of operating conditions and environmental specifications ([Section 1.3](#)).

The operating conditions of the motor are defined by:

- The thermal characteristics of the motor.
- The effectiveness of the medium that surrounds the motor to transfer heat away from the motor.
- The use of supplemental cooling.

Examples of what could cause the motor to overheat:

- Poor heat transfer away from the motor.
- The load is too high for the motor.
- The ambient temperature has increased above the expected operating conditions.

Refer to the motor torque curves ([Figure 1-4](#) to [Figure 1-5](#)) to see the safe region of operation for each motor. The example in [Figure 2-7](#) shows what the boundary for each torque curve means.

- The thermal limit of the motor will not be exceeded if the motor is operated within the region bounded by the Continuous Operating Curve.
- Motor operation in the region bounded by the Peak Operating Curve has to be limited in time or the temperature of the motor will exceed the thermal limit.

Figure 2-7: Operating Regions Example

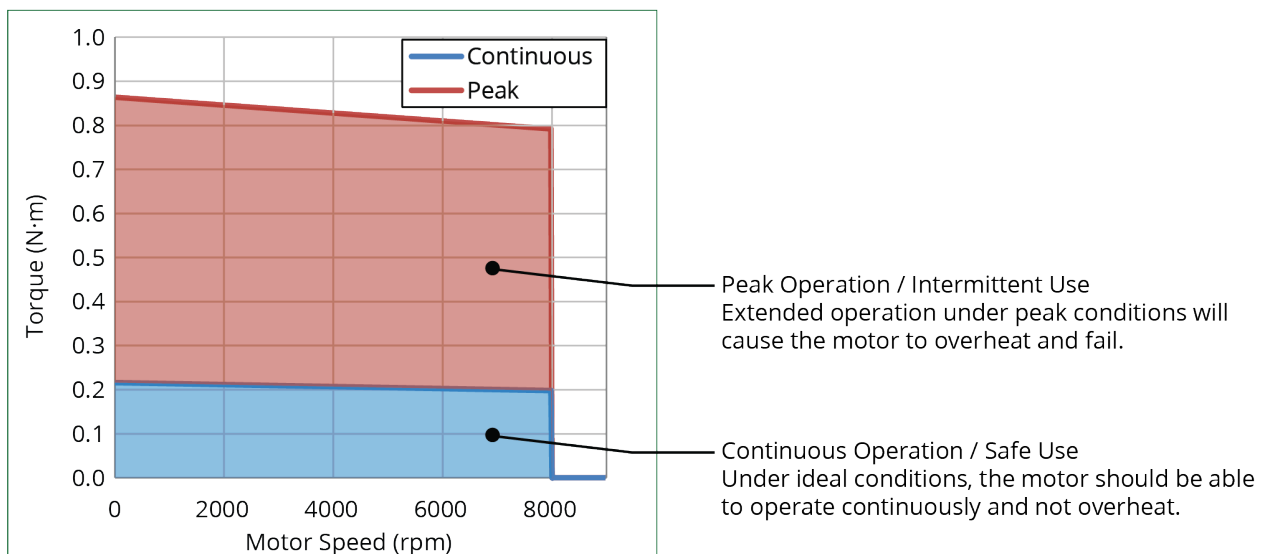

Chapter 3: Maintenance



DANGER: To minimize the possibility of bodily injury or death, disconnect all electrical power before you do maintenance or make adjustments to the equipment.

Inspect the BM/BMS motor at least once per month. You will have to determine a longer or shorter inspection interval based on the application and conditions, such as the duty cycle, speed, and environment.

Visually inspect the motor and cables to make sure that:

- the motor does not become too hot.
- the motor does not vibrate too much.
- you do not see evidence of burns or smell smoke.

You will also need to

- re-tighten loose motor-to-machine couplers.
- remove an accumulation of debris on the motor.
- replace or repair damaged cables.
- clean the motor and any components and cables if needed.
- assess any damage to the motor.

Cleaning

Motors should be wiped with a clean dry cloth to remove any grease, dirt, or other material that has accumulated on the motor. Do not use fluids and sprays so that you do not contaminate the internal parts of the motor. Be careful when you clean the motor so that you do not remove the text on the motor labels.

Lubrication

Aerotech BM/BMS rotary motors do not require lubrication. It is the responsibility of the customer or OEM to lubricate customer-supplied components.

Repairs

In general, it is not possible for field service personnel to repair and/or replace damaged or components that have malfunctioned. Repair typically requires that you return the unit to the factory.

Contact Aerotech Global Technical Support for more information.

This page intentionally left blank.

Appendix A: Warranty and Field Service

Aerotech, Inc. warrants its products to be free from harmful defects caused by faulty materials or poor workmanship for a minimum period of one year from date of shipment from Aerotech. Aerotech's liability is limited to replacing, repairing or issuing credit, at its option, for any products that are returned by the original purchaser during the warranty period. Aerotech makes no warranty that its products are fit for the use or purpose to which they may be put by the buyer, whether or not such use or purpose has been disclosed to Aerotech in specifications or drawings previously or subsequently provided, or whether or not Aerotech's products are specifically designed and/or manufactured for buyer's use or purpose. Aerotech's liability on any claim for loss or damage arising out of the sale, resale, or use of any of its products shall in no event exceed the selling price of the unit.

THE EXPRESS WARRANTY SET FORTH HEREIN IS IN LIEU OF AND EXCLUDES ALL OTHER WARRANTIES, EXPRESSED OR IMPLIED, BY OPERATION OF LAW OR OTHERWISE. IN NO EVENT SHALL AEROTECH BE LIABLE FOR CONSEQUENTIAL OR SPECIAL DAMAGES.

Return Products Procedure

Claims for shipment damage (evident or concealed) must be filed with the carrier by the buyer. Aerotech must be notified within thirty (30) days of shipment of incorrect material. No product may be returned, whether in warranty or out of warranty, without first obtaining approval from Aerotech. No credit will be given nor repairs made for products returned without such approval. A "Return Materials Authorization (RMA)" number must accompany any returned product(s). The RMA number may be obtained by calling an Aerotech service center or by submitting the appropriate request available on our website (www.aerotech.com). Products must be returned, prepaid, to an Aerotech service center (no C.O.D. or Collect Freight accepted). The status of any product returned later than thirty (30) days after the issuance of a return authorization number will be subject to review.

Visit [Global Technical Support Portal](#) for the location of your nearest Aerotech Service center.

Returned Product Warranty Determination

After Aerotech's examination, warranty or out-of-warranty status will be determined. If upon Aerotech's examination a warranted defect exists, then the product(s) will be repaired at no charge and shipped, prepaid, back to the buyer. If the buyer desires an expedited method of return, the product(s) will be shipped collect. Warranty repairs do not extend the original warranty period.

Fixed Fee Repairs - Products having fixed-fee pricing will require a valid purchase order or credit card particulars before any service work can begin.

All Other Repairs - After Aerotech's evaluation, the buyer shall be notified of the repair cost. At such time the buyer must issue a valid purchase order to cover the cost of the repair and freight, or authorize the product(s) to be shipped back as is, at the buyer's expense. Failure to obtain a purchase order number or approval within thirty (30) days of notification will result in the product(s) being returned as is, at the buyer's expense.

Repair work is warranted for ninety (90) days from date of shipment. Replacement components are warranted for one year from date of shipment.

Rush Service

At times, the buyer may desire to expedite a repair. Regardless of warranty or out-of-warranty status, the buyer must issue a valid purchase order to cover the added rush service cost. Rush service is subject to Aerotech's approval.

On-site Warranty Repair

If an Aerotech product cannot be made functional by telephone assistance or by sending and having the customer install replacement parts, and cannot be returned to the Aerotech service center for repair, and if Aerotech determines the problem could be warranty-related, then the following policy applies:

Aerotech will provide an on-site Field Service Representative in a reasonable amount of time, provided that the customer issues a valid purchase order to Aerotech covering all transportation and subsistence costs. For warranty field repairs, the customer will not be charged for the cost of labor and material. If service is rendered at times other than normal work periods, then special rates apply.

If during the on-site repair it is determined the problem is not warranty related, then the terms and conditions stated in the following "On-Site Non-Warranty Repair" section apply.

On-site Non-Warranty Repair

If any Aerotech product cannot be made functional by telephone assistance or purchased replacement parts, and cannot be returned to the Aerotech service center for repair, then the following field service policy applies:

Aerotech will provide an on-site Field Service Representative in a reasonable amount of time, provided that the customer issues a valid purchase order to Aerotech covering all transportation and subsistence costs and the prevailing labor cost, including travel time, necessary to complete the repair.

Service Locations

<https://www.aerotech.com/contact-sales.aspx?mapState=showMap>

USA, CANADA, MEXICO

Aerotech, Inc.
Global Headquarters

CHINA

Aerotech China
Full-Service Subsidiary

GERMANY

Aerotech Germany
Full-Service Subsidiary

TAIWAN

Aerotech Taiwan
Full-Service Subsidiary

UNITED KINGDOM

Aerotech United Kingdom
Full-Service Subsidiary

Appendix B: Revision History

Revision	Description
3.01	<ul style="list-style-type: none">• General Update• Specifications updated (Section 1.1.)
3.00	Declaration of Conformity updated.
2.10	Revision changes have been archived. If you need a copy of this revision, contact AerotechGlobal Technical Support.
2.09	
2.08	
2.07	
2.06	
2.05	
2.04	
2.03	
2.02	
2.01	
2.00	
1.04	
1.03	
1.02	
1.01	
1.00	

This page intentionally left blank.

Index

		BMS465 Motor Specifications	29
		Braycote® 602EF	39
	#		
2014/35/EU		7	
	A		
Altitude		38	
Atmosphere		38	
	B		
BM Motor Options		17	
BM24		21	
BM24 Model Dimensions (NEMA 17)		31	
BM24 Motor Specifications		21	
BM75		21	
BM75 Model Dimensions (NEMA 23)		32	
BM75 Motor Specifications		21	
BM130		21	
BM130 Model Dimensions (NEMA 23)		32	
BM130 Motor Specifications		21	
BM200 Model Dimensions (NEMA 23)		32	
BM200 Motor Specifications		23	
BM250 Model Dimensions (NEMA 34)		33	
BM250 Motor Specifications		23	
BM500 Model Dimensions (NEMA 34)		33	
BM500 Motor Specifications		23	
BM800 Model Dimensions (NEMA 42)		34	
BM800 Motor Specifications		25	
BM1400 Model Dimensions (NEMA 42)		34	
BM1400 Motor Specifications		25	
BMS Motor Options		19	
BMS35		27	
BMS35 Model Dimensions		35	
BMS35 Motor Specifications		27	
BMS60		27	
BMS60 Model Dimensions (NEMA 23)		36	
BMS60 Motor Specifications		27	
BMS100		27	
BMS100 Model Dimensions (NEMA 23)		36	
BMS100 Motor Specifications		27	
BMS280 Model Dimensions (NEMA 34)		37	
BMS280 Motor Specifications		29	
BMS465 Model Dimensions (NEMA 34)		37	
		C	
		clean	57
		Continuous Operating Curve	56
		-	
		-D25 Option	
		Feedback Connector Pinout	45
		Mating Connector Part Numbers (Motor Power Connector)	42,45
		Motor Power Connector Pinout	42
		-D25-4TS Option	
		Feedback Connector Pinout	46
		Limit Connector Pinout	47
		Mating Connector Part Numbers (Feedback Connector)	46
		Mating Connector Part Numbers (Limit Connector)	47
		Motor Power Connector Pinout	43
		-D25-5D Option	
		Feedback Connector Pinout	46
		Limit Connector Pinout	47
		Mating Connector Part Numbers (Feedback Connector)	46
		Mating Connector Part Numbers (Limit Connector)	47
		Mating Connector Part Numbers (Motor Power Connector)	43
		Motor Power Connector Pinout	43
		-D25-9D Option	
		Feedback Connector Pinout	46
		Limit Connector Pinout	47
		Mating Connector Part Numbers (Feedback Connector)	46
		Mating Connector Part Numbers (Limit Connector)	47
		-D25-9D-CMS Option	
		Feedback Connector Pinout	46
		Limit Connector Pinout	47
		Mating Connector Part Numbers (Feedback Connector)	46
		Mating Connector Part Numbers (Limit Connector)	47
		-D25-FLB Option	
		Feedback Connector Pinout	46
		Limit Connector Pinout	47
		Mating Connector Part Numbers (Feedback Connector)	46
		Mating Connector Part Numbers (Limit Connector)	47
		Motor Power Connector Pinout	43

	D			M	
Declaration of Conformity (EU)		7		Mating Connector Part Numbers	
Declaration of Conformity (UKCA)		8		Feedback Connector	
Dust Exposure		38		-D25-4TS Option	46
	E			-D25-5D Option	46
Electrical Warnings		12		-D25-9D Option	46
EU 2015/863		7		-D25-9D-CMS Option	46
EU Declaration of Conformity		7		-D25-FLB Option	46
	F			Limit Connector	
Feedback Connector Pinout				-D25-4TS Option	47
-D25 Option		45		-D25-5D Option	47
-D25-4TS Option		46		-D25-9D Option	47
-D25-5D Option		46		-D25-9D-CMS Option	47
-D25-9D Option		46		-D25-FLB Option	47
-D25-9D-CMS Option		46		Motor Power Connector	
-D25-FLB Option		46		-D25 Option	42,45
-MS Option		44		-D25-5D Option	43
	G			-MS Option	42,44
grease		39		Motor Lead Phasing with Oscilloscope	54
	H			Motor Power Conductors	48
Hall Phasing with Oscilloscope		55		Motor Power Connector Pinout	
Handling		15		-D25 Option	42
Humidity		38		-D25-4TS Option	43
	L			-D25-5D Option	43
label		15		-D25-FLB Option	43
Limit Connector Pinout				-MS Option	42
-D25-4TS Option		47		Motor Specifications	21
-D25-5D Option		47		Motor-Related Warnings	13
-D25-9D Option		47			
-D25-9D-CMS Option		47		-MS Option	
-D25-FLB Option		47		Feedback Connector Pinout	44
lubricant				Mating Connector Part Numbers (Motor Power Connector)	42,44
vacuum		39		Motor Power Connector Pinout	42
	P			MS3101A18-10P	42
				MS3102R20-29P	44
				packing list	15
				part number	15

Part Numbers

Feedback Mating Connector			R	
-D25-5D Option	46	repair		57
-D25-9D Option	46	Revision History		61
-D25-9D-CMS Option	46			
-D25-FLB Option	46		S	
Limit Mating Connector		serial number		15
-D25-4TS Option	47	Specifications		21
-D25-5D Option	47	stabilizing stage		16
-D25-9D Option	47	stage		
-D25-9D-CMS Option	47	stabilizing		16
-D25-FLB Option	47	Storage		15
Motor Mating Connector				
-D25 Option	45		T	
-D25-4TS Option	46			
-MS Option	42,44	Table of Contents		3
Motor Power Mating Connector		Temperature		38
-D25 Option	42	Test Setup Configuration		53
-D25-5D Option	43	Thermal Protective Device		50
Peak Operating Curve	56	Thermistor Interface Circuit		51
Pinout				
Feedback Connector			U	
-D25 Option	45	UKCA Declaration of Conformity		8
-D25-4TS Option	46	Use		38
-D25-5D Option	46			
-D25-9D Option	46		V	
-D25-9D-CMS Option	46	vacuum guidelines		39
-D25-FLB Option	46	vacuum lubricant (Braycote 602EF)		39
-MS Option	44			
Limit Connector			W	
-D25-4TS Option	47	Warnings		9
-D25-5D Option	47	Warranty and Field Service		59
-D25-9D Option	47	Wiring Guidelines		49
-D25-9D-CMS Option	47			
-D25-FLB Option	47			
Motor Power Connector				
-D25 Option	42			
-D25-4TS Option	43			
-D25-5D Option	43			
-D25-FLB Option	43			
-MS Option	42			
Protective Ground	48			

This page intentionally left blank.